

# CESSNA

## 172 AND SKYHAWK SERIES 1969 THRU 1976

# SERVICE MANUAL

---

---

**CHANGE**  
NOTICE

---

---

THIS REPRINT OF BASIC SERVICE MANUAL D972-13 DATED 1 JULY 1972 INCORPORATES CHANGE 1, DATED 1 JULY 1973, CHANGE 2, DATED 1 JULY 1974, AND CHANGE 3, DATED 15 JUNE 1975.

1 JULY 1972

D972-3-13-RPC-250-

CHANGED

15 JUNE 1975

**LIST OF EFFECTIVE PAGES**

NOTE: The portion of the text affected by the changes is indicated by a vertical line in the outer margins of the page. Changes to illustrations are indicated by miniature pointing hands.

Dates of issue for original and changed pages are:

Original . . . . . 1 July 1972  
 Change . . . . . 1 July 1973  
 Change . . . . . 1 July 1974  
 Change . . . . . 15 June 1975

TOTAL NUMBER OF PAGES IN THIS PUBLICATION IS 408, CONSISTING OF THE FOLLOWING:

Page No.	Change No.	Page No.	Change No.	Page No.	Change No.	Page No.	Change No.
*Title	3	*4-9 Blank	3	11A-5 thru 11A-9	0	16-29	0
*A	3	*5-1 thru 5-3	3	11A-10	1	*16-30	3
*1 thru 11	3	5-4	0	*11A-11 thru 11A-12	3	16-31	1
11	0	*5-5	3	11A-13 thru 11A-16	0	*16-32 thru 16-38	3
11 Blank	0	5-6 thru 5-8	1	*12-1	3	*16-1 thru 16-2	3
1-1	0	*5-8A thru 5-8B	3	12-2 thru 12-5	0	16-3 thru 16-4	0
1-2	2	*5-9 thru 5-15	3	12-6 thru 12-7	2	16-5 thru 16-6	2
1-3	1	5-16	1	12-8 thru 12-10	1	*16-7	3
1-4	0	*5-17 thru 5-18	3	12-11	0	16-8 thru 16-33	0
1-5	3	*5-18A	3	12-12 Blank	0	16-34 Blank	0
1-6 Blank	2	*5-18B Blank	3	*13-1 thru 13-2	3	*19-1 thru 19-2	3
*2-1	3	*5-19	3	13-3	0	*20-1 thru 20-3	3
2-2	2	5-20	0	13-4 Blank	0	20-4	0
2-2A	2	5-21	1	14-1 thru 14-3	0	*20-5	3
2-2B Blank	2	5-22 thru 5-23	0	14-3	2	20-6	0
2-3	1	*5-24	3	14-4	0	*20-7	3
*2-4	3	5-25 thru 5-26	0	15-1	1	20-8	0
2-5	0	5-27	1	*15-2	3	*20-9 thru 20-10	3
2-6	2	5-28 Blank	1	*15-2A	3	20-11	0
*2-7 thru 2-8	3	6-1 thru 6-2	0	*15-2B Blank	3	*20-12 thru 20-17	3
2-9	0	*6-3	3	*15-3 thru 15-4	3	20-18	0
*2-10 thru 2-14	3	6-4	0	*15-4A	3	*20-19 thru 20-22	3
*2-14A	3	*6-5	3	*15-4B Blank	3	*20-22A thru 20-22B	3
*2-14B Blank	3	6-6 thru 6-7	0	*15-5 thru 15-6	3	*20-23	3
*2-15	3	6-8 Blank	0	15-7 thru 15-8	0	20-24	2
2-16	2	7-1 thru 7-9	1	*15-9	3	*20-24A	3
*2-17 thru 2-18	3	7-10 thru 7-11	2	15-10 thru 15-12	0	*20-24B Blank	3
2-19 thru 2-20	1	7-12 Blank	2	15-13	2	20-25	2
2-21	2	*8-1	3	*15-14	3	*20-26	3
*2-22	3	8-2	0	15-15	2	20-27	0
2-23 thru 2-24	1	*8-3 thru 8-6	3	15-16 thru 15-17	0	*20-28 thru 20-29	3
*2-25 thru 2-26	3	*9-1 thru 9-7	3	15-18	1	*20-30 Blank	3
3-1	2	*9-8 Blank	3	15-19 thru 15-22	0	*20-31	3
3-2	0	10-1 thru 10-2	2	15-23	2	20-32	0
*3-3	3	*10-3 thru 10-6	3	*15-24 thru 15-25	3	20-33	3
3-4	0	10-7 thru 10-9	2	*15-26 Blank	3	20-34	0
*3-5 thru 3-6	3	*11-1	3	*16-1	3	20-35	2
*3-6A thru 3-6B	3	11-2	0	16-2 thru 16-4	0	20-36	1
*3-7	3	11-3	2	16-5 thru 16-6	1	*20-36A	3
3-8	0	*11-4 thru 11-7	3	16-7	0	*20-36B Blank	3
3-9	1	11-8	0	*16-8	3	20-37	0
*3-10	3	*11-9 thru 11-11	3	16-9 thru 16-12	0	*20-38	3
3-11 thru 3-12	1	11-12 thru 11-13	0	16-13	1	20-39 thru 20-40	1
*3-13	3	11-14 thru 11-15	2	*16-14	3	*20-41	3
3-14	1	11-16	1	16-15 thru 16-16	1	20-42	0
3-14A thru 3-14B	1	11-17 thru 11-20	0	16-17 thru 16-18	2	*20-43	3
3-15	0	11-21 thru 11-22	1	16-19 thru 16-21	1	20-44 thru 20-45	1
3-16	2	*11-23 thru 11-24	3	*16-22	3	*20-46	3
3-17 thru 3-18	0	11-25	2	16-22A	2	20-47	0
*3-19 thru 3-20	3	11-26 thru 11-27	0	*16-22B	3	*20-48	3
4-1	1	11-28 Blank	0	16-23 thru 16-24	1	20-49	0
4-2 thru 4-3	2	*11A-1	3	*16-24A	3	*20-50 thru 20-53	3
4-4	3	11A-2	0	16-24B	2	*20-54 Blank	3
4-5	0	*11A-3	3	16-25 thru 16-26	2	*20-55 thru 20-85	3
4-6 thru 4-7	3	11A-4	1	*16-27	3	*20-86 Blank	3
				16-28	2		

Upon receipt of the second and subsequent changes to this book, personnel responsible for maintaining this publication in current status should ascertain that all previous changes have been received and incorporated.

\* The asterisk indicates pages changed, added, or deleted by the current change.

## TABLE OF CONTENTS

SECTION	Page
1 GENERAL DESCRIPTION . . . . .	1-1
2 GROUND HANDLING, SERVICING, CLEANING, LUBRICATION AND INSPECTION . . . . .	2-1
3 FUSELAGE . . . . .	3-1
4 WINGS AND EMPENNAGE . . . . .	4-1
5 LANDING GEAR AND BRAKES . . . . .	5-1
6 AILERON CONTROL SYSTEM . . . . .	6-1
7 WING FLAP CONTROL SYSTEM . . . . .	7-1
8 ELEVATOR CONTROL SYSTEM . . . . .	8-1
9 ELEVATOR TRIM TAB CONTROL SYSTEM . . . . .	9-1
10 RUDDER CONTROL SYSTEM . . . . .	10-1
11 ENGINE (LYCOMING "BLUE-STREAK") . . . . .	11-1
11A ENGINE (CONTINENTAL) . . . . .	11A-1
12 FUEL SYSTEM . . . . .	12-1
13 PROPELLER . . . . .	13-1
14 UTILITY SYSTEMS . . . . .	14-1
15 INSTRUMENTS AND INSTRUMENT SYSTEMS . . . . .	15-1
16 ELECTRICAL SYSTEMS . . . . .	16-1
17 ELECTRONIC SYSTEMS (DELETED) (See Page iii) . . . . .	
18 STRUCTURAL REPAIR . . . . .	18-1
19 PAINTING . . . . .	19-1
20 WIRING DIAGRAMS . . . . .	20-1

**CROSS REFERENCE LISTING OF POPULAR  
NAME VS. MODEL NUMBER AND SERIALS**

All aircraft, regardless of manufacturer, are certificated under model number designations. However, popular names are often used for marketing purposes. To provide a consistent method of referring to the various aircraft, model numbers will be used in this publication unless names are required to differentiate between versions of the same basic model. The following table provides a cross reference listing of popular name vs. model numbers.

POPULAR NAME	MODEL YEAR	MODEL	SERIALS	
			BEGINNING	ENDING
172 or SKYHAWK  172, SKYHAWK or SKYHAWK II  SKYHAWK or SKYHAWK II	1969	172K	17257162	17258486
	1970	172K	17258487	17259223
	1971	172L	17259224	17259903
	1972	172L	17259904	17260758
	1973	172M	17260759	17261898
	1974	172M	17261899	17263458
	1975	172M	17263459	17265684
1976	172M	17265685		
REIMS 172 REIMS/CESSNA F172  REIMS/CESSNA F172 SKYHAWK, SKYHAWK II	1969	F172H	F17200560	F17200654
	1970	F172H	F17200655	F17200754
	1971	F172K	F17200755	F17200804
	1972	F172L	F17200805	F17200904
	1973	F172M	F17200905	F17201034
	1974	F172M	F17201035	F17201234
	1975	F172M	F17201235	F17201384
1976	F172M	F17201385		

## FOREWORD

This manual contains factory recommended procedures and instructions for ground handling, servicing and maintaining Cessna Model 172-Series aircraft. This includes the Models 172, Skyhawk, Reims 172 and Reims/Cessna F172. The Reims versions of the Model 172 and Skyhawk are identical to the Model 172 and Skyhawk, through Model year 1971, except that they are powered by O-300-D Rolls Royce engines. Beginning with the 1972 Models, both 172 and F172-Series aircraft are powered by "Blue-Streak" (Lycoming) engines. Besides serving as a reference for the experienced mechanic, this manual also covers step-by-step procedures for the less experienced man. This manual should be kept in a handy place for ready reference. If properly used, it will better enable the mechanic to maintain Cessna 172-Series aircraft and thereby establish a reputation for reliable service.

The information in this manual is based on data available at the time of publication, and is supplemented and kept current by service letters and service news letters published by Cessna Aircraft Company. These are sent to all Cessna Dealers so that they have the latest authoritative recommendations for servicing Cessna aircraft. Therefore, it is recommended that Cessna owners utilize the knowledge and experience of the factory-trained Dealer Service Organization.

In addition to the information in this Service Manual, a group of Vendor publications is available from the Cessna Service Parts Center which describe complete disassembly, overhaul, and parts breakdown of some of the various vendor equipment items. A listing of the available publications is issued periodically in service letters.

Information for Nav-O-Matic Autopilots, Electronic Communications, and Navigation Equipment are not included in this manual. These manuals are available from the Cessna Service Parts Center.

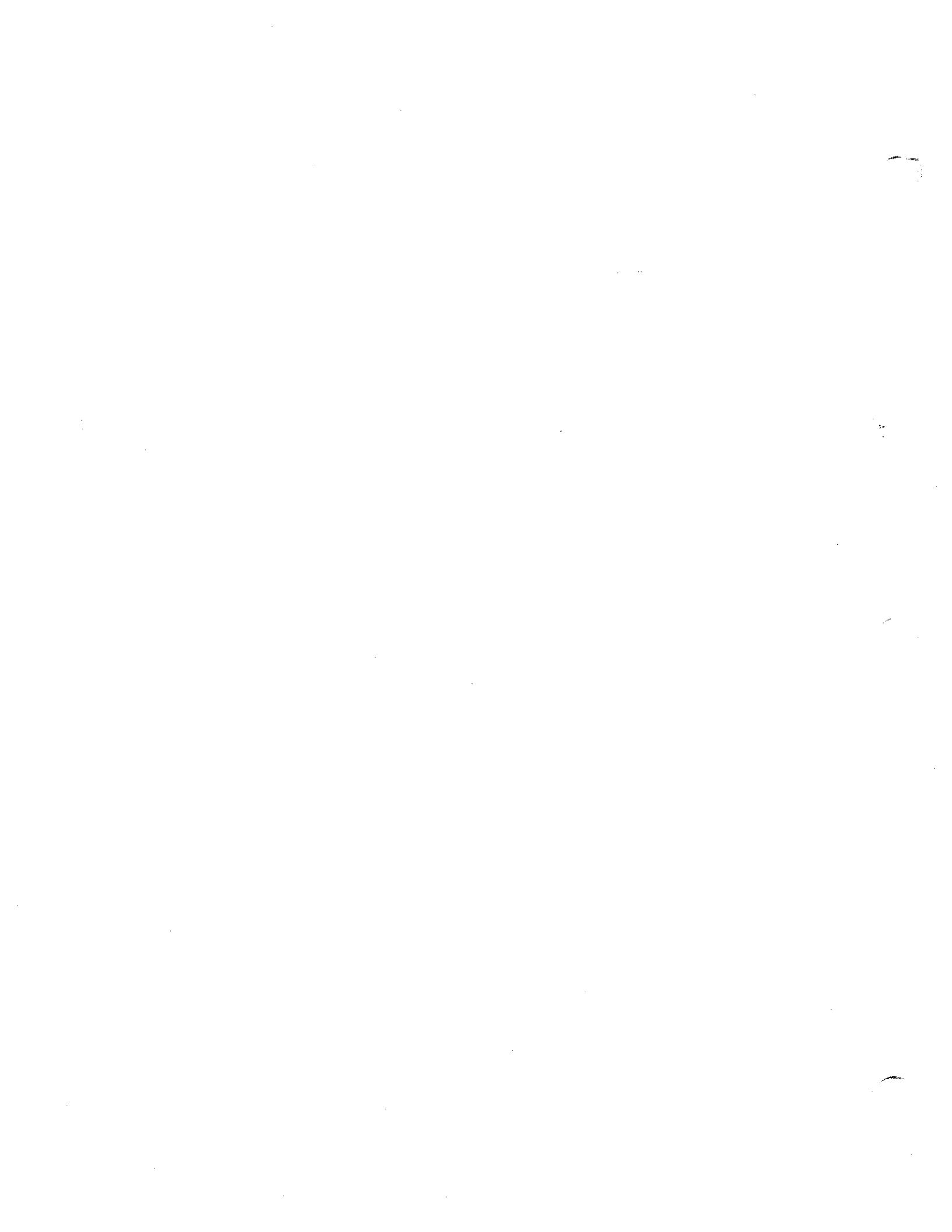

SECTION 1  
GENERAL DESCRIPTION

TABLE OF CONTENTS	Page		
GENERAL DESCRIPTION . . . . .	1-1	Aircraft Specifications . . . . .	1-1
Model 172-Series . . . . .	1-1	Stations . . . . .	1-1
Description . . . . .	1-1	Torque Values . . . . .	1-1

1-1. GENERAL DESCRIPTION.

1-2. MODEL 172-SERIES.

1-13. DESCRIPTION. Cessna Model 172 Series aircraft, described in this manual, are high-wing monoplanes of all-metal, semimonocoque construction. These aircraft are equipped with a fixed tricycle landing gear. Thru 1970 Models, they are equipped with flat spring-steel main landing gear struts. Beginning with 1971 Models, these aircraft are equipped with tubular spring-steel main gear struts. The steerable nose gear is equipped with an air/hydraulic fluid shock strut. Four-place seating is standard, and a double-width, fold-up auxiliary rear seat may be installed as optional equipment. Thru 1971 Models, F172-Series aircraft are equipped with six-cylinder air-cooled O-300-Series, Continental engines, manufactured under license by Rolls Royce. Model 172-Series aircraft, and F172-Series aircraft, beginning with 1972 Models, are powered by four-cylinder, horizontally opposed, air-cooled "Blue Streak" (Lycoming) engines. Each of the engines drives are all-metal, fixed-pitch pro-

PELLER. Model 172-Series aircraft feature rear side windows, a "wrap-around" rear window and a swept-back fin and rudder.

1-4. AIRCRAFT SPECIFICATIONS. Leading particulars of these aircraft, with dimensions based on gross weight, are given in figure 1-1. If these dimensions are used for constructing a hangar or computing clearances, remember that such factors as nose gear strut inflation, tire pressures, tire sizes and load distribution may result in some dimensions that are considerably different from those listed.

1-5. STATIONS. Station diagrams are shown in figures 1-2 and 1-3 to assist in locating equipment when a written description is inadequate or impractical.

1-6. TORQUE VALUES. A chart of recommended nut torque values is shown in figure 1-4. These torque values are recommended for all installation procedures contained in this manual, except where other values are stipulated. They are not to be used for checking tightness of installed parts during service.

GROSS WEIGHT . . . . .	2300 lb	NOTE
FUEL CAPACITY		
Standard Wing (Total) . . . . .	42 gal.	These specifications are applicable to both Model 172 and F172-Series aircraft, except as indicated.
Standard Wing (Usable) . . . . .	38 gal.	
Long-Range Wing (Total) . . . . .	52 gal.	
Long-Range Wing (Usable) . . . . .	48 gal.	
OIL CAPACITY		
(Without External Filter) . . . . .	8 qt	
(With External Filter) . . . . .	9 qt	
ENGINE MODEL		
172-Series (Refer to Section 11 for Engine Data) . . . . .	LYCOMING O-320 Series	
F172-Series (Refer to Section 11A thru 1971 Models) . . . . .	CONTINENTAL O-300 Series	
F172-Series (Refer to Section 11 Beginning with 1972 Models) . . . . .	LYCOMING O-320 Series	
PROPELLER (Fixed Pitch) . . . . .	76" MCCAULEY	
MAIN WHEEL TIRES	6.00 x 6, 4-Ply Rating	
Pressure (Thru 1970 Models) . . . . .	24 psi	
Pressure (Beginning with 1971 Models) . . . . .	29 psi	
NOSE WHEEL TIRE (Standard)	5.00 x 5, 4-Ply Rating	
Pressure (Thru 1970 Models) . . . . .	26 psi	
Pressure (Beginning with 1971 Models) . . . . .	31 psi	
NOSE WHEEL TIRE (172-Series Only, Optional)	6.00 x 6, 4-Ply Rating	
Pressure . . . . .	26 psi	
NOSE GEAR STRUT PRESSURE (Strut Extended) . . . . .	45 psi	
WHEEL ALIGNMENT (Flat Spring Struts)		
Camber . . . . .	3° to 5°	
Toe-In . . . . .	0" to .06"	
WHEEL ALIGNMENT (Tubular Spring Struts)		
Camber . . . . .	2° to 4°	
Toe-In . . . . .	0" to .18"	
* (Tubular Gear is non-adjustable)		
AILERON TRAVEL		
Up . . . . .	20° ± 1°	
Down . . . . .	15° ± 1°	
WING FLAP TRAVEL		
(Thru 1972 Models) . . . . .	0° to 40° ± 2°	
(Beginning with 1973 Models) . . . . .	0° to 40°, +0° -2°	
RUDDER TRAVEL (Measured parallel to water line)		
Right . . . . .	16° 10' ± 1°	
Left . . . . .	16° 10' ± 1°	
RUDDER TRAVEL (Measured perpendicular to hinge line)		
Right . . . . .	17° 44' ± 1°	
Left . . . . .	17° 44' ± 1°	
ELEVATOR TRAVEL		
Up . . . . .	28°, +1° - 0°	
Down . . . . .	23°, +1° - 0°	
ELEVATOR TRIM TAB TRAVEL		
Up . . . . .	28°, +1° - 0°	
Down . . . . .	13°, +1° - 0°	
PRINCIPAL DIMENSIONS		
Wing Span (Conventional Wing Tip) . . . . .	36' 2"	
Wing Span (Conical-Camber Wing Tip) . . . . .	35' 10"	
Wing Span (Conical-Camber With Strobe Lights) . . . . .	36'	
Tail Span . . . . .	11'	
Length . . . . .	26' 11"	
Fin Height (Maximum with Nose Gear Depressed and Flashing Beacon Installed on Fin) . . . . .	8' - 9 1/2"	
Track Width (Thru 1970 Models) . . . . .	7' 2"	
Track Width (Beginning with 1971 Models) . . . . .	8' - 3 1/2"	
BATTERY LOCATION . . . . .	Firewall	

\* No provisions are made for aligning wheels on tubular gear aircraft. The tolerances provided are to be used only for checking existing wheel alignment.

Figure 1-1. Aircraft Specifications



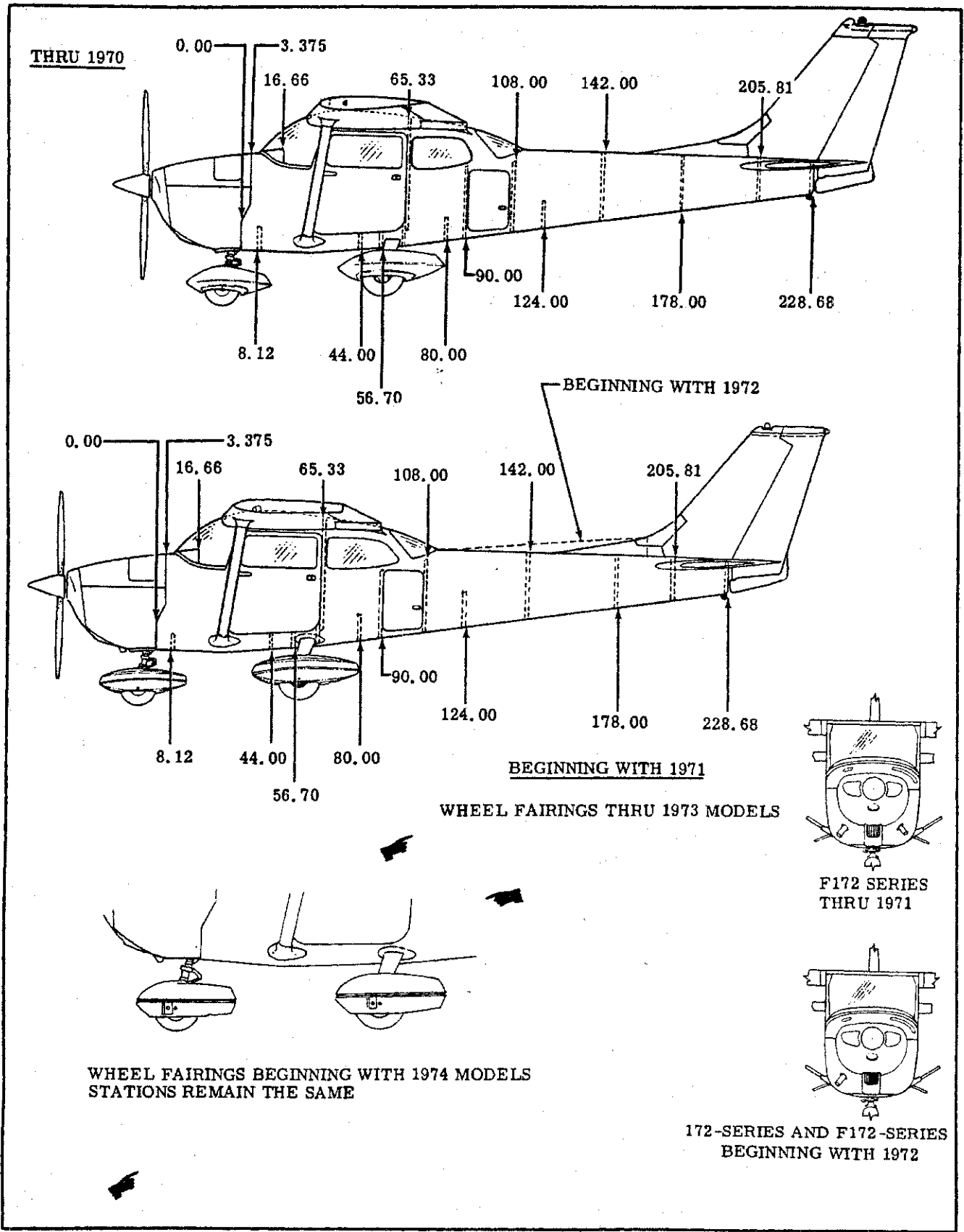

Figure 1-2. Reference Stations

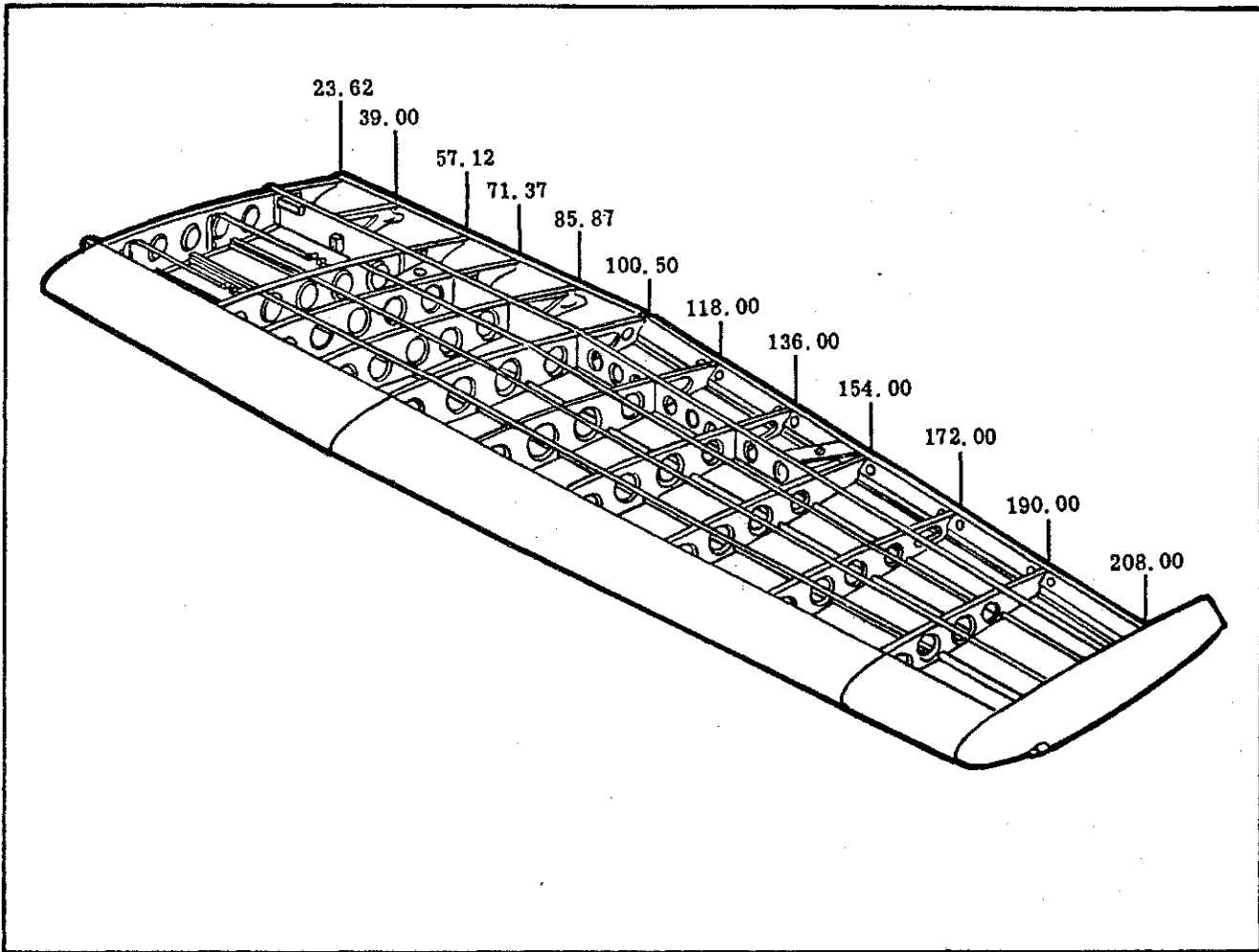

Figure 1-3. Wing Stations

**SHOP NOTES:**

---



---



---



---



---



---



---

## RECOMMENDED NUT TORQUES

THE TORQUE VALUES STATED ARE POUND-INCHES, RELATED ONLY TO STEEL NUTS ON OIL-FREE CADMIUM PLATED THREADS.				
FINE THREAD SERIES				
TAP SIZE	TENSION		SHEAR	
	TORQUE		TORQUE	
	STD (NOTE 1)	ALT (NOTE 2)	STD (NOTE 3)	ALT (NOTE 2)
8-36	12-15		7-9	
10-32	20-25	20-28	12-15	12-19
1/4-28	50-70	50-75	30-40	30-48
5/16-24	100-140	100-150	60-85	60-106
3/8-24	160-190	160-260	95-110	95-170
7/16-20	450-500	450-560	270-300	270-390
1/2-20	480-690	480-730	290-410	290-500
9/16-18	800-1000	800-1070	480-600	480-750
5/8-18	1100-1300	1100-1600	660-780	660-1060
3/4-16	2300-2500	2300-3350	1300-1500	1300-2200
7/8-14	2500-3000	2500-4650	1500-1800	1500-2900
1-14	3700-5500	3700-6650	2200-3300	2200-4400
1-1/8-12	5000-7000	5000-10000	3000-4200	3000-6300
1-1/4-12	9000-11000	9000-16700	5400-6600	5400-10000
COARSE THREAD SERIES				
	(NOTE 4)		(NOTE 5)	
8-32	12-15		7-9	
10-24	20-25		12-15	
1/4-20	40-50		25-30	
5/16-18	80-90		48-55	
3/8-16	160-185		95-100	
7/16-14	235-255		140-155	
1/2-13	400-480		240-290	
9/16-12	500-700		300-420	
5/8-11	700-900		420-540	
3/4-10	1150-1600		700-950	
7/8-9	2200-3000		1300-1800	
1-8	3700-5000		2200-3000	
1-1/8-8	5500-6500		3300-4000	
1-1/4-8	6500-8000		4000-5000	
NOTES				
1. Covers AN310, AN315, AN345, AN363, MS20365, MS21042, MS21044, MS21045 and MS21046.				
2. When using AN310 or AN320 castellated nuts where alignment between the bolt and cotter pin slots is not reached using normal torque values, use alternate torque values or replace the nut.				
3. Covers AN316, AN320, MS20364 and MS21245.				
4. Covers AN363, MS20365, MS21042, MS21043, MS21044, MS21045 and MS21046.				
5. Covers AN340.				
CAUTION				
DO NOT REUSE SELF-LOCKING NUTS.				
The above values are recommended for all installation procedures contained in this manual, except where other values are stipulated. They are not to be used for checking tightness of installed parts during service.				

Figure 1-4. Torque Values

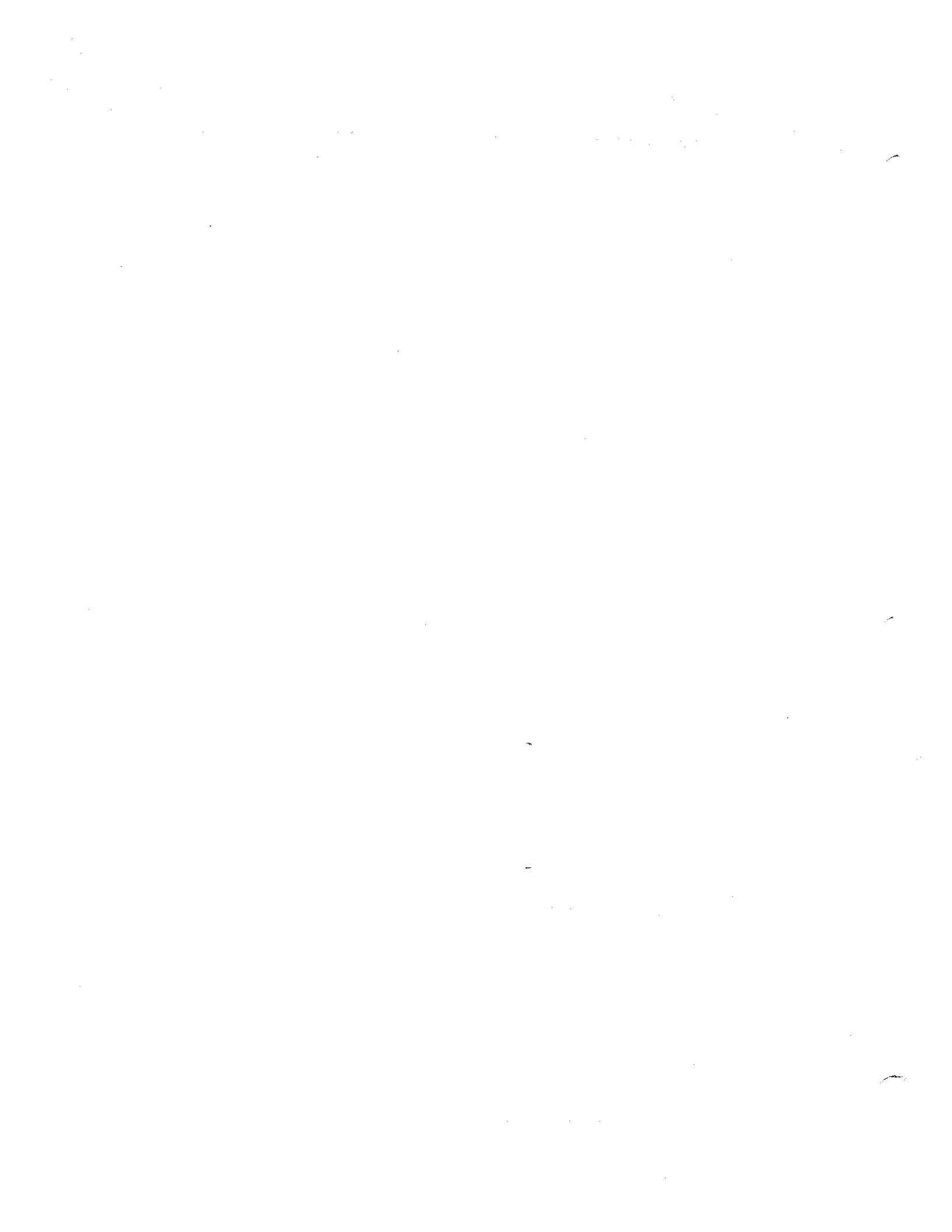

SECTION 2

GROUND HANDLING, SERVICING, CLEANING, LUBRICATION AND INSPECTION

TABLE OF CONTENTS

	Page		
GROUND HANDLING . . . . .	2-1	Vacuum System Filter . . . . .	2-9
Towing . . . . .	2-1	Battery . . . . .	2-9
Hoisting . . . . .	2-3	Tires . . . . .	2-9
Jacking . . . . .	2-3	Nose Gear Shock Strut . . . . .	2-9
Levelling . . . . .	2-3	Nose Gear Shimmy Dampener . . . . .	2-10
Parking . . . . .	2-3	Hydraulic Brake System . . . . .	2-10
Tie-Down . . . . .	2-3	CLEANING . . . . .	2-10
Flyable Storage . . . . .	2-3	Windshield and Windows . . . . .	2-10
Returning Aircraft To Service . . . . .	2-3	Plastic Trim . . . . .	2-10
Temporary Storage . . . . .	2-3	Painted Surfaces . . . . .	2-10
Inspection During Storage . . . . .	2-4	Aluminum Surfaces . . . . .	2-10
Returning Aircraft To Service . . . . .	2-4	Engine Compartment . . . . .	2-11
Indefinite Storage . . . . .	2-4	Upholstery and Interior . . . . .	2-11
Inspection During Storage . . . . .	2-6	Propeller . . . . .	2-11
Returning Aircraft To Service . . . . .	2-6	Wheels . . . . .	2-11
SERVICING . . . . .	2-6	LUBRICATION . . . . .	2-11
Fuel . . . . .	2-6	Wheel Bearings . . . . .	2-11
Fuel Drains . . . . .	2-6	Nose Gear Torque Links . . . . .	2-11
Carburetor Drain Plug Inspection . . . . .	2-6	Wing Flap Actuator . . . . .	2-11
Engine Oil . . . . .	2-7	Fuel Selector Valve . . . . .	2-12
Engine Induction Air Filter . . . . .	2-8	INSPECTION . . . . .	2-19

2-1. GROUND HANDLING.

2-2. TOWING. Moving the aircraft by hand is accomplished by using the wing struts and landing gear struts as push points. A tow bar attached to the nose gear should be used for steering and maneuvering the aircraft on the ground. When no tow bar is available, press down at the horizontal stabilizer front spar adjacent to the fuselage to raise the nose wheel off the ground. With the nose wheel clear of the ground, the aircraft can be turned by pivoting it about the main wheels.

**CAUTION**

When towing the aircraft, never turn the nose wheel more than 30 degrees either side of center or the nose gear will be damaged. Do not push on control surfaces or outboard empennage surfaces. When pushing on the tailcone, always apply pressure at a bulkhead to avoid buckling the skin.

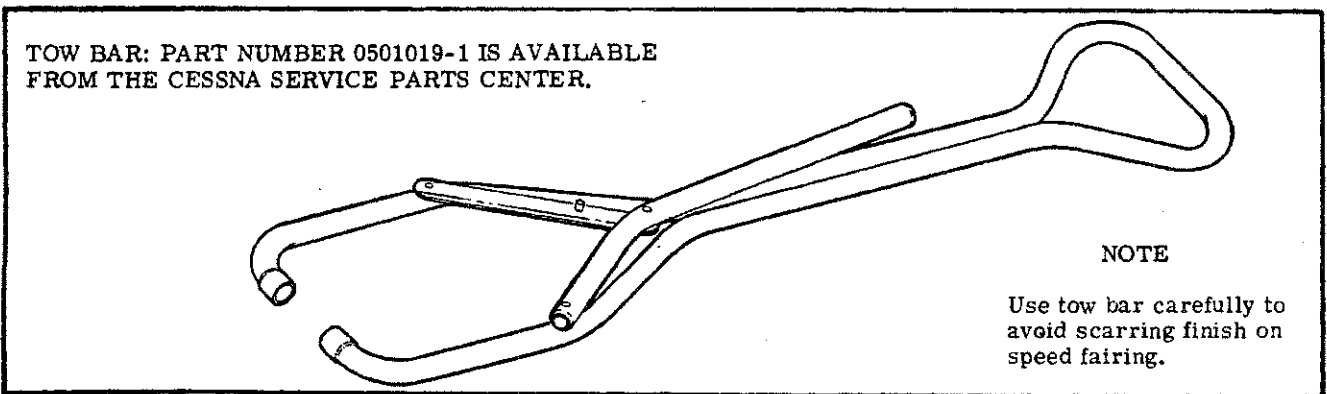
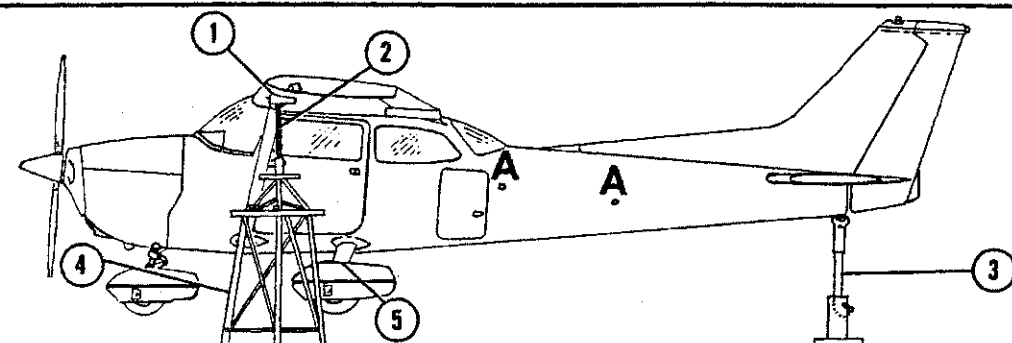
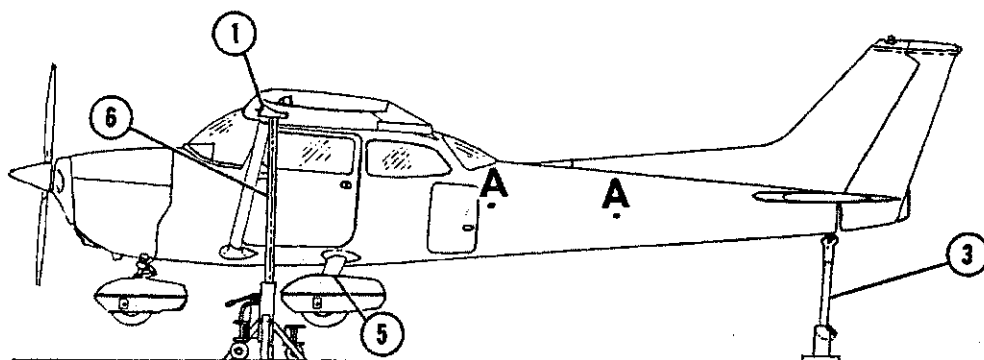

Figure 2-1. Tow Bar



REFER TO SHEET 2  
FOR JACKING  
INFORMATION



ITEM NUMBER	TYPE AND NUMBER	REMARKS
①	Block (Jack point not available)	1x4x4 padded with 1/4" rubber
②	Jack	Any short jack of capable capacity
③	Universal tail stand	Any tail stand of capable capacity
④	Cessna #SE-576 (41-1/2" high)	Universal jack stand (FOR USE WITH ITEM 2)
⑤	Cessna #10004-98 Cessna #0541208-1 Built-in jack pad	Jack point * (SEE CAUTION) Jack point † (SEE NOTE 5) Part of step bracket †
⑥	#2-170 Basic jack #2-70 Slide tube (Use with item 1)	Closed height: 69-1/2 inches; extended height: 92" (Insert slide tube extension into basic jack)

\* THRU 17259223 AND F17200754

# 17259224 THRU 17260554 AND F17200755 THRU F17200879

† BEGINNING WITH 17260555 AND F17200880

Corresponding points on both upper door sills may be used to level the aircraft laterally.

Prior to 1972 Models, reference points for leveling the aircraft longitudinally are the top of the tailcone between rear window and vertical fin.

Beginning with 1972 Models, reference points for longitudinal leveling of aircraft are two screws on left side of tailcone at zero waterline. These are indicated in illustration by **A**

(Also refer to paragraph 2-5)

Figure 2-2. Jacking and Leveling (Sheet 1 of 2)

## JACKING INFORMATION

1. Wing jacks are placed under front spar of wing just outboard of wing strut, and must extend far enough to raise wheels off ground, and must be of adequate strength.
2. Attach a suitable stand to the tie-down ring. Be sure tail stand weighs enough to keep tail down and under all conditions that it is strong enough to support any weight that might be placed on it (place shot bags or sand bags on tail stand. In addition, the base of adjustable tail stand is to be filled with concrete for additional weight as a safety factor.
3. Operate jacks evenly until desired height is reached.

### CAUTION

When using universal jack point (10004-98), flexibility of the gear strut will cause the main wheel to slide inboard as the wheel is raised, tilting the jack. The jack must be lowered for a second operation. Jacking both wheels simultaneously with universal jack points is not recommended. Universal jack point may be used to raise only one main wheel. DO NOT USE brake casting as a jack point.

4. Items (4), (5) and (6) are available from the Cessna Service Parts Center.
5. On tubular gear aircraft, the only fairing requiring removal is the fuselage-to-tube gear fairing. Jack pad is inserted on tube in area between fuselage and upper end of tube fairing, then jack aircraft as required.

## SHOP NOTES:

---

---

---

---

---

---

---

---





2-3. **HOISTING.** The aircraft may be lifted with a hoist of two-ton capacity by using hoisting rings, which are optional equipment, or by means of suitable slings. The front sling should be hooked to each upper engine mount at the firewall, and the aft sling should be positioned around the fuselage at the first bulkhead forward of the leading edge of the stabilizer. If the optional hoisting rings are used, a minimum cable length of 60 inches for each cable is required to prevent bending of the eyebolt-type hoisting rings. If desired, a spreader jig may be fabricated to apply vertical force to the eyebolts.

2-4. **JACKING.** Refer to figure 2-2 for jacking procedures.

2-5. **LEVELING.** Corresponding points on both upper door sills may be used to level the aircraft laterally. Prior to 1972 models, the reference point for leveling the aircraft longitudinally is the top of the tailcone, between the rear window and vertical fin. Beginning with 1972 models, the reference points for longitudinally leveling the aircraft, are the two screws located on the left side of the tailcone. Refer to figure 2-2 for screw locations.

2-6. **PARKING.** Parking precautions depend principally on local conditions. As a general precaution, set parking brake or chock the wheels and install the controls lock. In severe weather and high wind conditions, tie down the aircraft as outlined in paragraph 2-7 if a hangar is not available.

2-7. **TIE-DOWN.** When mooring the aircraft in the open, head into the wind if possible. Secure control surfaces with the internal control lock and set brakes.

### **CAUTION**

Do not set parking brakes during cold weather when accumulated moisture may freeze the brakes or when the brakes are overheated.

After completing the preceding, proceed to moor the aircraft as follows:

- a. Tie ropes, cables, or chains to the wing tie-down fittings located at the upper end of each wing strut. Secure the opposite ends of ropes, cables, or chains to ground anchors.
- b. Secure rope (no chains or cables) to forward mooring ring and secure opposite end to ground anchor.
- c. Secure the middle of a rope to the tail tie-down ring. Pull each end of rope away at a 45 degree angle and secure to ground anchors at each side of tail.
- d. Secure control lock on pilot control column. If control lock is not available, tie pilot control wheel back with front seat belt.
- e. These aircraft are equipped with a spring-loaded steering system which affords protection against normal wind gusts. However, if extremely high wind gusts are anticipated, additional external locks may be installed.

2-8. **FLYABLE STORAGE.** Flyable storage is defined as a maximum of 30 days non-operational stor-

age and/or the first 25 hours of intermittent engine operation.

### **NOTE**

The aircraft is delivered from Cessna with a Corrosion Preventive Aircraft Engine Oil (MIL-C-6529, Type II, RUST BAN). This engine oil is a blend of aviation grade straight mineral oil and a corrosion preventive compound. This engine oil should be used for the first 50 hours of engine operation. Refer to paragraph 2-21 for oil changes during the first 50 hours of operation.

During the 30 day non-operational storage or the first 25 hours of intermittent engine operation, every seventh day the propeller shall be rotated through five revolutions, without running the engine. If the aircraft is stored outside, tie-down in accordance with paragraph 2-7. In addition, the pitot tube, static air vents, air vents, openings in the engine cowling, and other similar openings shall have protective covers installed to prevent entry of foreign material. After 30 days, aircraft should be flown for 30 minutes or ground run-up until oil has reached operating temperature.

2-9. **RETURNING AIRCRAFT TO SERVICE.** After flyable storage, returning the aircraft to service is accomplished by performing a thorough pre-flight inspection. At the end of the first 25 hours of engine operation, drain engine oil, clean oil screens and change external oil filter element. Service engine with correct grade and quantity of engine oil. Refer to figure 2-4 and paragraph 2-21 for correct grade of engine oil.

2-10. **TEMPORARY STORAGE.** Temporary storage is defined as aircraft in a non-operational status for a maximum of 90 days. The aircraft is constructed of corrosion resistant alclad aluminum, which will last indefinitely under normal conditions if kept clean, however, these alloys are subject to oxidation. The first indication of corrosion on unpainted surfaces is in the form of white deposits or spots. On painted surfaces, the paint is discolored or blistered. Storage in a dry hangar is essential to good preservation and should be procured if possible. Varying conditions will alter the measures of preservation, but under normal conditions in a dry hangar, and for storage periods not to exceed 90 days, the following methods of treatment are suggested:

- a. Fill fuel tanks with correct grade of gasoline.
- b. Clean and wax aircraft thoroughly.
- c. Clean any oil or grease from tires and coat tires with a tire preservative. Cover tires to protect against grease and oil.
- d. Either block up fuselage to relieve pressure on tires or rotate wheels every 30 days to change supporting points and prevent flat spotting the tires.
- e. Lubricate all airframe items and seal or cover all openings which could allow moisture and/or dust to enter.

#### NOTE

The aircraft battery serial number is recorded in the aircraft equipment list. To assure accurate warranty records, the battery should be re-installed in the same aircraft from which it was removed. If the battery is returned to service in a different aircraft, appropriate record changes must be made and notification sent to the Cessna Claims Department.

- f. Remove battery and store in a cool dry place; service the battery periodically and charge as required.

#### NOTE

An engine treated in accordance with the following may be considered protected against normal atmospheric corrosion for a period not to exceed 90 days.

- g. Disconnect spark plug leads and remove upper and lower spark plugs from each cylinder.

#### NOTE

The preservative oil must be Lubricating Oil-Contact and Volatile, Corrosion Inhibited, MIL-L-46002, Grade 1 or equivalent. The following oils are approved for spraying operations by Teledyne Continental Motors, Nucle Oil 105 - Daubert Chemical Co., 4700 So. Central Ave., Chicago, Illinois, Petractec VA-Pennsylvania Refining Co., Butler, Pennsylvania, Ferro-Gard 1009G - Ranco Laboratories, Inc., 3617 Brownsville Rd., Pittsburg, Pennsylvania. The following oils are approved for spraying operation by Lycoming, Socony Averex 901, or Esso Rust-Ban 626, or equivalent.

- h. Using a portable pressure sprayer, atomize spray preservative oil through the upper spark plug hole of each cylinder with the piston in a down position. Rotate crankshaft as each pair of cylinders is sprayed.
  - i. After completing step "h," rotate crankshaft so that no piston is at a top position. If the aircraft is to be stored outside, stop two-bladed propeller so that blades are as near horizontal as possible to provide maximum clearance with passing aircraft.
  - j. Again spray each cylinder without moving the crankshaft to thoroughly cover all interior surfaces of the cylinder above the piston.
  - k. Install spark plugs and connect spark plug leads.
  - l. Apply preservative oil to the engine interior by spraying approximately two ounces of the preservative oil through the oil filler tube.
  - m. Seal all engine openings exposed to the atmosphere using suitable plugs or non-hygroscopic tape. Attach a red streamer at each point that a plug or tape is installed.
  - n. If the aircraft is to be stored outside, perform the procedures outlined in paragraph 2-7. In addition, the pitot tube, static source vents, air vents, openings in the engine cowling and other similar

openings should have protective covers installed to prevent entry of foreign material.

- o. Attach a warning placard to the propeller to the effect that the propeller shall not be moved while the engine is in storage.

#### 2-11. INSPECTION DURING STORAGE.

- a. Inspect airframe for corrosion at least once a month and remove dust collections as frequently as possible. Clean and wax as required.
- b. Inspect the interior of at least one cylinder through the spark plug hole for corrosion at least once a month.

#### NOTE

Do not move crankshaft when inspecting interior of cylinder for corrosion.

- c. If at the end of the 90 day period, the aircraft is to be continued in non-operational storage, again perform the procedural steps "g thru o" of paragraph 2-10.

#### 2-12. RETURNING AIRCRAFT TO SERVICE. After temporary storage, use the following procedures to return the aircraft to service.

- a. Remove aircraft from blocks and check tires for proper inflation. Check for proper nose gear strut inflation.
- b. Check battery and install.
- c. Check that oil sump has proper grade and quantity of engine oil.
- d. Service induction air filter and remove warning placard from propeller.
- e. Remove materials used to cover openings.
- f. Remove spark plugs from engine.
- g. While spark plugs are removed, rotate propeller several revolutions to clear excess rust preventive oil from cylinders.
- h. Clean, gap and install spark plugs. Torque plugs to the value specified in Section 11 or 11A; connect spark plug leads.
- i. Check fuel strainer. Remove and clean filter screen if necessary. Check fuel tanks and fuel lines for moisture and sediment, drain enough fuel to eliminate moisture and sediment.
- j. Perform a thorough pre-flight inspection, then start and warm-up engine.

#### 2-13. INDEFINITE STORAGE. Indefinite storage is defined as aircraft in a non-operational status for an indefinite period of time. Engines treated in accordance with the following may be considered protected against normal atmosphere corrosion, provided the procedure outlined in paragraph 2-14 are performed at the intervals specified.

- a. Operate engine until oil temperature reaches normal operating range. Drain engine oil sump and reinstall drain plug.
- b. Fill oil sump to normal operating capacity with corrosion preventive mixture which has been thoroughly mixed and pre-heated to a minimum of 221°F at the time it is added to the engine.

## NOTE

Corrosion preventive mixture consists of one part compound MIL-C-6529, type I, mixed with three parts new lubricating oil of the grade recommended for service. Lycoming recommends Esso Rust-Ban 628 or equivalent. Continental Motors Corporation recommends Cosmoline No. 1223, supplied by E. F. Houghton & Co., 305 W. Le-High Avenue, Philadelphia, Pa. During all spraying operations corrosion mixture is pre-heated to 221° to 250°F.

c. Immediately after filling the oil sump with corrosion preventive mixture, fly the aircraft for a period of time not to exceed a maximum of 30 minutes.

d. With engine operating at 1200 to 1500 rpm and induction air filter removed, spray corrosion preventive mixture into induction airbox, at the rate of one-half gallon per minute, until heavy smoke comes from exhaust stack, then increase the spray until the engine is stopped.

## CAUTION

Injecting corrosion-preventive mixture too fast can cause a hydrostatic lock.

e. Do not rotate propeller after completing step "d."

f. Remove all spark plugs and spray corrosion-preventive mixture, which has been pre-heated to 221° to 250°F, into all spark plug holes to thoroughly cover interior surfaces of cylinders.

g. Install lower spark plugs and install solid plugs, and install dehydrator plugs in upper spark plug holes. Be sure that dehydrator plugs are blue in color when installed.

h. Cover spark plug lead terminals with shipping plugs (AN4060-1) or other suitable covers.

i. With throttle in full open position, place a bag of desiccant in the carburetor intake and seal opening with moisture resistant paper and tape.

j. Place a bag of desiccant in the exhaust tail-pipe(s) and seal openings with moisture resistant tape.

k. Seal cold air inlet to the heater muff with moisture resistant tape.

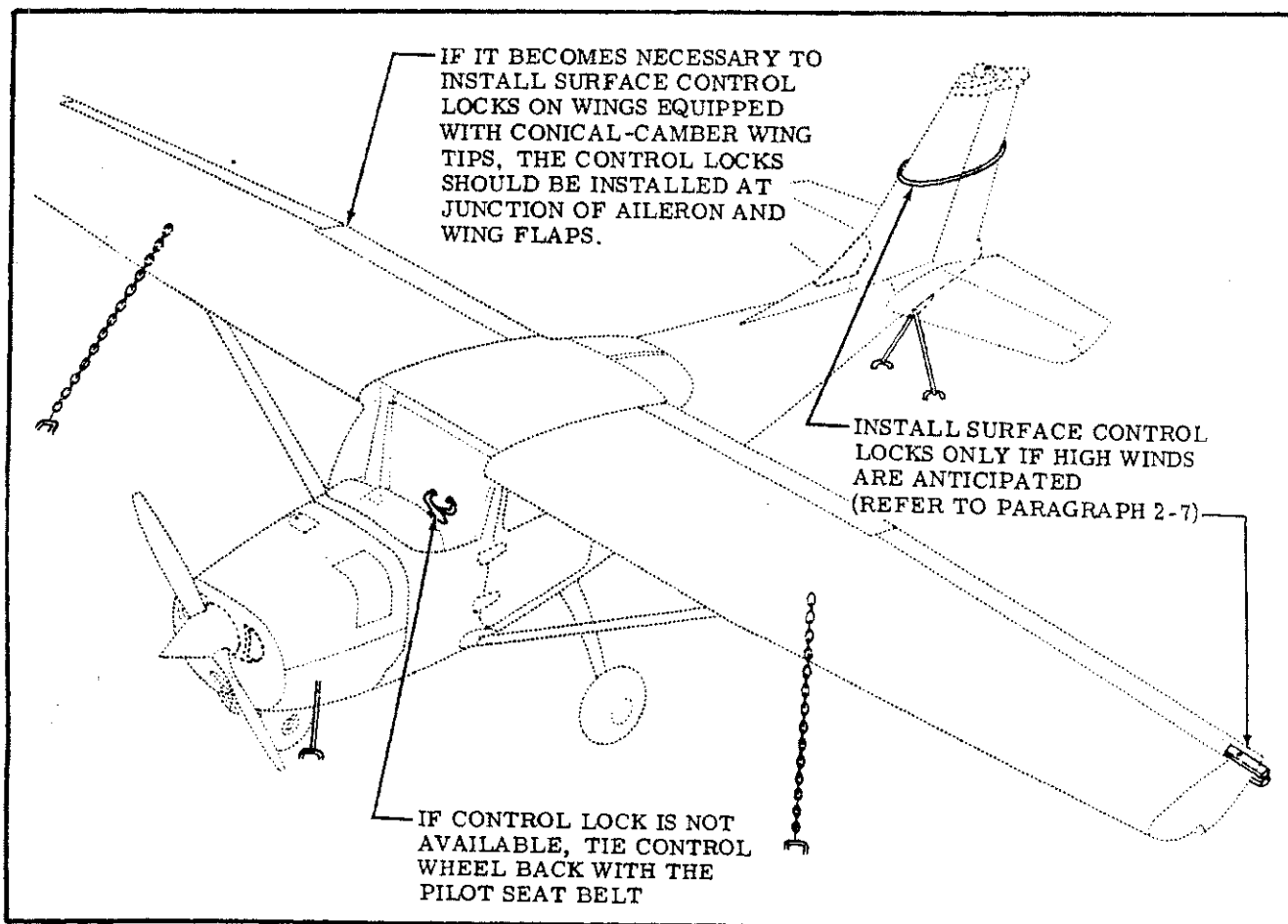

Figure 2-3. Tie-Down Details

- l. Seal engine breather by inserting a protex plug in the breather hose and clamping in place.
- m. Seal all other engine openings exposed to atmosphere using suitable plugs or non-hygroscopic tape.

**NOTE**

Attach a red streamer to each place plugs or tape is installed. Either attach red streamers outside of the sealed area with tape or to the inside of the sealed area with safety wire to prevent wicking of moisture into the sealed area.

- n. Drain corrosion-preventive mixture from engine sump and reinstall drain plug.

**NOTE**

The corrosion-preventive mixture is harmful to paint and should be wiped from painted surfaces immediately.

- o. Attach a warning placard on the throttle control knob, to the effect that the engine contains no lubricating oil. Placard the propeller to the effect that it should not be moved while the engine is in storage.
- p. Prepare airframe for storage as outlined in paragraph 2-10 thru step "f."

**NOTE**

As an alternate method of indefinite storage, the aircraft may be serviced in accordance with paragraph 2-10 providing the aircraft is run-up at maximum intervals of 60 days and then reserviced per paragraph 2-10.

**2-14. INSPECTION DURING STORAGE.** Aircraft in indefinite storage shall be inspected as follows:

- a. Inspect cylinder protex plugs each 7 days.
- b. Change protex plugs if their color indicates an unsafe condition.
- c. If the dehydrator plugs have changed color in one half of the cylinders, all desiccant material in the engine shall be replaced with new material.
- d. Every 6 months respray the cylinder interiors with corrosion-preventive mixture.

**NOTE**

Before spraying, inspect the interior of one cylinder for corrosion through the spark plug hole and remove at least one rocker box cover and inspect the valve mechanism.

**2-15. RETURNING AIRCRAFT TO SERVICE.**

After indefinite storage, use the following procedure to return the aircraft to service.

- a. Remove aircraft from blocks and check tires for correct inflation. Check for correct nose gear strut inflation.
- b. Check battery and install.
- c. Remove all materials used to seal and cover openings.
- d. Remove warning placards posted at throttle and propeller.
- e. Remove and clean engine oil screen, then re-

- install and safety. On aircraft that are equipped with an external oil filter, install new filter element.
- f. Remove oil sump drain plug and drain sump. Install and safety drain plug.

**NOTE**

The corrosion-preventive mixture will mix with the engine lubricating oil, so flushing the oil system is not necessary. Draining the oil sump will remove enough of the corrosion-preventive mixture.

- g. Service and install the induction air filter.
- h. Remove dehydrator plugs and spark plugs or plugs installed in spark plug holes and rotate propeller by hand several revolutions to clear corrosion-preventive mixture from cylinders.
  - i. Clean, gap, and install spark plugs. Torque plugs to the value listed in Section 11 or 11A.
  - j. Check fuel strainer. Remove and clean filter screen. Check fuel tanks and fuel lines for moisture and sediment, and drain enough fuel to eliminate.
  - k. Perform a thorough pre-flight inspection, then start and warm-up engine.
    - 1. Thoroughly clean aircraft and flight test aircraft.

**2-16. SERVICING.**

**2-17.** Servicing requirements are shown in figure 2-4. The following paragraphs supplement this figure by adding details not included in the figure.

**2-18. FUEL.** Fuel tanks should be filled immediately after flight to reduce condensation. Tank capacities are listed in figure 1-1. The recommended fuel grade to be used is given in figure 2-4.

**2-19. FUEL DRAINS.** are located at various places throughout the fuel system. Refer to Section 12 for location of the various drains in the system. The strainer drain valve is an integral part of the fuel strainer assembly. The strainer drain is equipped with a control which is located adjacent to the oil dipstick. Access to the control is through the oil dipstick access door. Remove drain plugs and open strainer drain at the intervals specified in figure 2-4. Also, during daily inspection of the fuel strainer, if water is found in the fuel strainer, there is a possibility that the wing tank sumps or fuel line contain water. Therefore, all fuel drain plugs should be removed and all water drained from the system. To activate drain valve for fuel sampling, place cup up to valve and depress valve with rod protruding from cup. (Refer to figure 12-3.)

**2-20. CARBURETOR DRAIN PLUG INSPECTION.** In order to prevent the possibility of thread sealant contamination in the carburetor float chamber, cleaning and inspection of the carburetor should be accomplished at each 100-hour inspection and any-time water in the fuel is suspected.

- a. With the fuel valve OFF, remove carburetor drain plug and clean off any sealant present on the end of the plug or in the threads on the plug.
- b. Inspect drain plug hole in the carburetor and re-

move any sealant remaining in the hole.

c. Turn fuel valve to ON to flush float chamber and drain plug chamber while probing drain plug hole to ascertain that all residue of sealant material is dislodged and washed out of the chamber. Flushing operation should last 15 to 30 seconds.

d. A second flushing should then be accomplished and the drained fuel retained for inspection to insure that no sealant particles are present.

e. Install drain plug as follows:

1. Install drain plug in carburetor 1-1/2 to 2 turns.

2. Apply NS-40 (RAS-4) MIL-T-5544 (Antiseize, Graphite Petrolatum) or equivalent to plug threads.

3. Tighten and safety drain plug.

f. Turn fuel valve ON and inspect for evidence of fuel leakage.

**2-21. ENGINE OIL.** Check engine lubricating oil with the dipstick five to ten minutes after the engine has been stopped. The aircraft should be in as near a level position as possible when checking the engine oil, so that a true reading is obtained. Engine oil should be drained while the engine is still hot, and the nose of the aircraft should be raised slightly for more positive draining of any sludge which may have collected in the engine oil sump. Engine oil should be changed every six months, even though less than the specified hours have accumulated. Reduce these intervals for prolonged operations in dusty areas, in cold climates where sludging conditions exist, or where short flights and long idle periods are encountered, which cause sludging conditions. Always change oil, clean oil screens, and clean and/or change external filter element whenever oil on the dipstick appears dirty. Aviation grade oil conforming to AVCO Lycoming Specification No. 301 and Service Instruction No. 1014, and to any revisions or supplements thereto, shall be used in the "Blue Streak" (Lycoming) engine. Ashless dispersant oil conforming to Continental Motors Specification MHS-24 and all revisions or supplements thereto and conforming with current Continental Aircraft Engine Service Bulletins shall be used in the Continental engine.

#### NOTE

New or newly-overhauled engines should be operated on aviation grade straight mineral oil until the first oil change. If an ashless dispersant oil is used in a new or newly-overhauled engine, high oil consumption may be experienced. The anti-friction additives in detergent and dispersant oils will retard "break-in" of the pistons, rings and cylinder walls. This condition can be avoided by the use of straight mineral oil. The aircraft is delivered from Cessna with a Corrosion Preventive Aircraft Engine Oil (MIL-C-6529, Type II, RUST BAN). If oil must be added

during the first 25 hours, use only aviation grade straight mineral oil (non-detergent) conforming to Specification No. MIL-L-6082. After the first 25 hours of operation, drain engine oil sump and clean both the oil suction strainer and oil pressure screen. If an optional oil filter is installed, change filter element at this time. Refill sump with straight mineral oil (non-detergent) and use until a total of 50 hours have accumulated or oil consumption has stabilized, then change to ashless dispersant oil.

When changing engine oil, remove and clean oil screens, or install a new filter element on aircraft equipped with an external oil filter. An oil quick-drain valve may be installed. This valve provides a quick and cleaner method of draining the engine oil. This valve is installed in the oil drain port of the oil sump, and allows oil to be drained by attaching a hose over the fitting end and pushing up, causing the oil to drain through the hose into a container. To drain the engine oil, proceed as follows:

a. Operate engine until oil temperature is at normal operating temperature.

b. (With Quick-Drain Valve.) Attach a hose to the quick-drain valve in oil sump. Push upon quick-drain valve until it locks open, and allow oil to drain through hose into container.

c. (Without Quick-Drain Valve.) Remove oil drain plug from engine sump and allow oil to drain into a container.

d. After engine oil has drained, close quick-drain valve and remove hose. Install and safety drain plug.

e. Remove and clean oil screen, or change external oil filter element.

f. Service engine with correct quantity and grade of engine oil.

#### NOTE

Refer to inspection charts for intervals for changing oil and filter elements.

#### NOTE

Oil capacities for the different models are given in the following chart. To minimize loss of oil through the breather, fill to specified oil level on dipstick for normal operation (flight of less than three hours duration). For extended flight, fill to FULL mark on dipstick. Do not operate with less than MINIMUM-FOR-FLIGHT quantities listed. If an external oil filter is installed, one additional quart of oil is required when filter element is changed.

MODEL	CAPACITY (TOTAL)	CAPACITY (TOTAL WITH FILTER)	NORMAL OPERATION	MINIMUM FOR FLIGHT
172	8	9	7	6

When adding or changing oil, use aviation grade oil in accordance with the following chart.

"BLUE STREAK" (Lycoming) ENGINE			
MODEL	AMBIENT TEMPERATURE RANGE	GRADE	
		STRAIGHT MINERAL OIL*	ASHLESS DISPERSANT OIL*
172 AND F172 (1972 & ON)	ABOVE 60°F 30° TO 90°F 0° TO 70°F BELOW 10°F	SAE 50 SAE 40 SAE 30 SAE 20	SAE 40 OR SAE 50 SAE 40 SAE 30 OR SAE 40 SAE 30
*AVIATION GRADE OILS CONFORMING TO AVCO LYCOMING SPECIFICATION NO. 301 AND SERVICE INSTRUCTION NO. 1014, AND TO ANY REVISIONS OR SUPPLEMENTS THERETO, MUST BE USED.			
CONTINENTAL ENGINE			
MODEL	AMBIENT TEMPERATURE**	GRADE***	
F172 (THRU 1971)	ABOVE 40°F BELOW 40°F	SAE 40 SAE 20	
** WHEN OPERATING TEMPERATURES OVERLAP INDICATED RANGES, USE THE LIGHTER GRADE OF OIL. *** AVIATION GRADE ASHLESS DISPERSANT OILS CONFORMING TO CONTINENTAL MOTORS SPECIFICATION MHS-24 AND ALL REVISIONS AND SUPPLEMENTS THERETO MUST BE USED EXCEPT AS NOTED IN THIS PARAGRAPH. REFER TO CURRENT CONTINENTAL AIRCRAFT ENGINE SERVICE BULLETINS FOR FUTHER RECOMMENDATIONS.			

2-22. ENGINE INDUCTION AIR FILTER. The induction air filter keeps dust and dirt from entering the induction system. The value of maintaining the air filter in a good clean condition can never be overstressed. More engine wear is caused through the use of a dirty or damaged air filter than is generally believed. The frequency with which the filter should be removed, inspected, and cleaned will be determined primarily by aircraft operating conditions. A good general rule however, is to remove, inspect, and clean the filter at least every 50 hours of engine operating time and more frequently if warranted by operating conditions. Some operators prefer to hold spare induction air filters at their home base of operation so that a clean filter is always readily available for use. Under extremely dusty conditions, daily servicing of the filter is recommended. Two types of filters have been used. One is a flock-coated, oiled filter and the other is a dry, paper-media filter.

NOTE

Early Model F172-series was equipped with a flock-coated, oiled filter when it left the factory. However, new filters ordered from the Cessna Service Parts Center will be the dry type with an improved filtering element. The Model 172-series is equipped with the dry type filter.

To service the flock-coated, oiled filter, proceed as follows:

- a. Remove filter from aircraft.
- b. Wash filter thoroughly, soiled face down in solvent (Federal Specification P-S-661 or equivalent).
- c. Drain and dry filter, then dip flock-coated screen filter in the same grade of oil used in the engine and allow excess oil to drain off.

d. Be sure air box is clean, inspect filter and replace if damaged.

#### NOTE

A damaged filter may have broken filtering panels or the flock coating may be missing from the filtering panels, which will allow unfiltered air to enter the induction system. Any filter that appears doubtful, shall have a new filter installed in its place.

e. Install filter at entrance to air box with gasket on aft face of filter frame and with air flow arrow on filter pointed in the correct direction.

To service the dry type filter, proceed as follows:

a. Remove filter from aircraft.

#### NOTE

Use care to prevent damage to filter element when cleaning filter with compressed air.

b. Clean filter by blowing with compressed air (not over 100 psi) from direction opposite of normal air flow. Arrows on filter case indicate direction of normal air flow.

#### CAUTION

Do not use solvent or cleaning fluids to wash filter. Use only a water and household detergent solution when washing the filter.

c. After cleaning as outlined in step "b," the filter may be washed, if necessary, in a solution of warm water and a mild household detergent. A cold water solution may be used.

#### NOTE

The filter assembly may be cleaned with compressed air a maximum of 30 times or it may be washed a maximum of 20 times. A new filter should be installed after using 500 hours of engine operating time or one year, whichever should occur first. However, a new filter should be installed at anytime the existing filter is damaged. A damaged filter may have sharp or broken edges in the filtering panels which would allow unfiltered air to enter the induction system. Any filter that appears doubtful, shall have a new filter installed in its place.

d. After washing, rinse filter with clear water until rinse water draining from filter is clear. Allow water to drain from filter and dry with compressed air (not over 100 psi).

#### NOTE

The filtering panels of the filter may become distorted when wet, but they will return to their original shape when dry.

e. Be sure air box is clean, inspect filter. If filter is damaged, install a new filter.

f. Install filter at entrance to air box with gasket on aft face of filter frame and with air flow arrows on filter frame pointed in the correct direction.

2-23. VACUUM SYSTEM FILTER. The vacuum system central air filter keeps dirt and dust from entering the vacuum operated instruments. Change central air filter element every 500 hours of operating time and whenever suction gage reading drops below 4.6 inches of mercury. Also, do not operate the vacuum system with the filter removed, or a vacuum line disconnected as particles of dust or other foreign matter may enter the system and damage the gyros.

2-24. BATTERY. Battery servicing involves adding distilled water to maintain the electrolyte even with the horizontal baffle plate at the bottom of the filler holes, checking the battery cable connections, and neutralizing and cleaning off and spilled electrolyte or corrosion. Use bicarbonate of soda (baking soda) and water to neutralize electrolyte or corrosion. Follow with a thorough flushing with water. Brighten cables and terminals with a wire brush, then coat with petroleum jelly before connecting. The battery box also should be checked and cleaned if any corrosion is noted. Distilled water, not acid or "rejuvenators," should be used to maintain electrolyte level. Check the battery every 50 hours (or at least every 30 days) oftener in hot weather. See Section 16 for detailed battery removal, installation and testing.

2-25. TIRES. Maintain tire pressure at the air pressures specified in figure 1-1. When checking tire pressure, examine tires for wear, cuts, bruises, and slippage. Remove oil, grease, and mud from tires with soap and water.

#### NOTE

Recommended tire pressures should be maintained. Especially in cold weather, remember that any drop in temperature of the air inside a tire causes a corresponding drop in air pressure.

2-26. NOSE GEAR SHOCK STRUT. The nose gear shock strut requires periodic checking to ensure that the strut is filled with hydraulic fluid and is inflated to the correct air pressure. To service the nose gear shock strut, proceed as follows:

a. Remove valve cap and release air pressure.

b. Remove valve housing.

c. Compress nose gear to its shortest length and fill strut with hydraulic fluid to the bottom of the filler hole.

d. Raise nose of aircraft, extend and compress strut several times to expel any entrapped air, then lower nose of aircraft and repeat step "c."

e. With strut compressed, install valve housing assembly.

f. With nose wheel off ground, inflate strut. Shock strut pressure is listed in Section 1.

#### NOTE

The nose landing gear shock strut will normally require only a minimum amount of service. Maintain the strut extension pressure, as shown in figure 1-1. Lubricate landing gear as shown in figure 2-5. Check the landing gear daily for general cleanliness, security of mounting, and for hydraulic fluid leakage. Keep machined surfaces wiped free of dirt and dust, using a clean lint-free cloth saturated with MIL-H-5606 hydraulic fluid or kerosene. All surfaces should be wiped free of excessive hydraulic fluid.

2-27. NOSE GEAR SHIMMY DAMPENER. The shimmy dampener should be serviced at least every 50 hours. The shimmy dampener must be filled completely with fluid, free of entrapped air, to serve its purpose. To service the shimmy dampener, proceed as follows:

- a. Remove shimmy dampener from aircraft.
- b. While holding the dampener in a vertical position with fitting end pointed downward, pull fitting end of the dampener shaft to its limit of travel.
- c. While holding dampener in this position, fill dampener through open end of cylinder with hydraulic fluid.
- d. Push the shaft upward slowly to seal off the filler hole.
- e. Clean dampener with solvent. Be sure to keep the shaft protruding through the filler hole until dampener is installed on the aircraft.
- f. Install dampener on aircraft.

#### NOTE

Keep the shimmy dampener, especially the exposed portions of the dampener piston shaft, clean to prevent collection of dust and grit which could cut the seals in the dampener barrel. Keep machined surfaces wiped free of dirt and dust, using a clean lint-free cloth saturated with MIL-H-5606 hydraulic fluid or kerosene. All surfaces should be wiped free of excessive hydraulic fluid.

2-28. HYDRAULIC BRAKE SYSTEMS. Check brake master cylinders and refill with hydraulic fluid as specified in the inspection charts. Bleed the brake system of entrapped air whenever there is a spongy response to the brake pedals. Refer to Section 5 for filling and bleeding of the brakes.

2-29. CLEANING.

2-30. Keeping the aircraft clean is important. Besides maintaining the trim appearance of the aircraft, cleaning lessens the possibility of corrosion and makes inspection and maintenance easier.

2-31. WINDSHIELD AND WINDOWS. Windshield and windows should be cleaned carefully with plenty of fresh water and a mild detergent, using the palm of the hand to feel and dislodge any caked dirt or mud.

A sponge, soft cloth, or chamois may be used, but only as a means of carrying water to the plastic. Rinse thoroughly, then dry with a clean moist chamois. Do not rub the plastic with a dry cloth as this builds up an electrostatic charge which attracts dust. Oil and grease may be removed by rubbing lightly with a soft cloth moistened with Stoddard solvent.

#### CAUTION

Do not use gasoline, alcohol, benzene, acetone, carbon tetrachloride, fire extinguisher fluid, de-icer fluid, lacquer thinner, or glass window cleaning spray. These solvents will soften and craze the plastic.

After washing, the plastic windshield and windows should be cleaned with an aircraft windshield cleaner. Apply the cleaner with soft cloths and rub with moderate pressure. Allow the cleaner to dry, then wipe it off with soft flannel cloths. A thin, even coat of wax, polished out by hand with soft flannel cloths, will fill in minor scratches and help prevent further scratching. Do not use a canvas cover on the windshield or windows unless freezing rain or sleet is anticipated since the cover may scratch the plastic surface.

2-32. PLASTIC TRIM. The instrument panel, plastic trim, and control knobs need only be wiped with a damp cloth. Oil and grease on the control wheel and control knobs can be removed with a cloth moistened with Stoddard solvent. Volatile solvents, such as mentioned in paragraph 2-31, must never be used since they soften and craze the plastic.

2-33. PAINTED SURFACES. The painted exterior surfaces of the aircraft, under normal conditions, require a minimum of polishing and buffing. Approximately 15 days are required for acrylic or lacquer paint to cure completely; in most cases, the curing period will have been completed prior to delivery of the aircraft. In the event that polishing or buffing is required within the curing period, it is recommended that the work be done by an experienced painter. Generally, the painted surfaces can be kept bright by washing with water and mild soap, followed by a rinse with water and drying with cloths or chamois. Harsh or abrasive soaps or detergents which could cause corrosion or make scratches should never be used. Remove stubborn oil and grease with a cloth moistened with Stoddard solvent. After the curing period, the aircraft may be waxed with a good automotive wax. A heavier coating of wax on the leading edges of the wing and tail and on the engine nose cap will help reduce the abrasion encountered in these areas.

2-34. ALUMINUM SURFACES. The aluminum surfaces require a minimum of care, but should never be neglected. The aircraft may be washed with clean water to remove dirt and may be washed with non-alkaline grease solvents to remove oil and/or grease. Household type detergent soap powders are effective cleaners, but should be used cautiously since some of them are strongly alkaline. Many good aluminum cleaners, polishes, and waxes are available from



commercial suppliers of aircraft products.

**2-35. ENGINE AND ENGINE COMPARTMENT.** The engine should be kept clean since dirty cooling fins and baffle plates can cause overheating of the engine. Also, cleaning is essential to minimize any danger of fire and provide for easier inspection of components. The entire engine cowling may be removed to facilitate engine and interior cowl cleaning. Wash down the engine and components with a suitable solvent, such as Stoddard solvent or equivalent, then dry thoroughly with compressed air.

#### **CAUTION**

Particular care should be given to electrical equipment before cleaning. Solvent should not be allowed to enter magnetos, starters, alternators, voltage regulators, and the like. Hence, these components should be protected before saturating the engine with solvent. Any fuel, oil, and air openings should be covered before washing the engine with solvent. Caustic cleaning solutions should not be used. After cleaning engine, re-lubricate all control arms and moving parts.

**2-36. UPHOLSTERY AND INTERIOR.** Keeping the upholstery and interior trim clean prolongs upholstery fabric and interior trim life. To clean the interior proceed as follows:

- a. Empty all ash trays and refuse containers.
- b. Brush or vacuum clean the upholstery and carpet to remove dust and dirt.
- c. Wipe leather and plastic trim with a damp cloth.
- d. Soiled upholstery fabrics and carpet may be cleaned with a foam-type detergent used according to the manufacturer's instructions.
- e. Oil spots and stains may be cleaned with household spot removers, used sparingly. Before using any solvent, read the instructions on the container and test it on an obscure place in the fabric to be cleaned. Never saturate the fabric with volatile solvent; it may damage the padding and backing material.
- f. Scrape sticky material from fabric with a dull knife, then spot clean the area.

#### **2-37. PROPELLER.**

a. Wash hub and blade with a soft cloth and Stoddard cleaning solvent or equivalent, then dry thoroughly with compressed air. The propeller should be wiped occasionally with an oily cloth, then wiped with a dry cloth. In salt water areas this will assist in corrosion proofing the propeller.

**2-38. WHEELS.** The wheels should be washed periodically and examined for corrosion, chipped paint, and cracks or dents in the wheel halves or in the flanges or hubs. If defects are found remove and repair in accordance with Section 5. Discard cracked wheel halves, flanges or hubs and install new parts.

#### **2-39. LUBRICATION.**

**2-40.** Lubrication requirements are shown in figure 2-5. Before adding grease to grease fittings, wipe dirt from fitting. Lubricate until grease appears around parts being lubricated, and wipe excess grease from parts. The following paragraphs supplement figure 2-5 by adding details.

**2-41. WHEEL BEARINGS.** Clean and repack the wheel bearings at first 100-hour inspection and at each 500-hour inspection thereafter. If more than the usual number of take-offs and landings are made, extensive taxiing is required, or the aircraft is operated in dusty areas or under seacoast conditions, cleaning and lubrication of the wheel bearings shall be accomplished at each 100-hour inspection.

**2-42. NOSE GEAR TORQUE LINKS.** Lubricate nose gear torque links every 50 hours. When operating in dusty conditions, more frequent lubrication is required.

#### **2-43. WING FLAP ACTUATOR.**

a. On aircraft prior to Serials 17259905 and F172-00805, not modified by Service Kit SK150-37B and SK150-41, proceed as follows:

1. At each 100 hour inspection, inspect wing flap actuator jack screw and ball retainer assembly for lubrication, and lubricate if required. Also, remove, clean and lubricate jack screw whenever actuator slippage is experienced. If lubrication is required, proceed as follows:

- a. Gain access to actuator by removing appropriate inspection plates on lower surface of wing.
- b. Expose jack screw by operating flaps to full-down position.
- c. Wipe a small amount of lubricant from jack screw with a rag and examine for condition. (Lubricant should not be dirty, sticky, gummy or frothy in appearance.)
- d. Inspect wiped area on jack screw for presence of hard scale deposit. Previous wiping action will have exposed bare metal if no deposit is present.
- e. If any of the above conditions exist, clean and relubricate jack screw as outlined in steps "f" thru "r".

f. Remove actuator from aircraft in accordance with procedures outlined in Section 7.

g. Remove all existing lubricant from jack screw and torque tube by running the nut assembly to the end of the jack screw away from the gear box, and soaking the nut assembly and jack screw in Stoddard solvent.

#### **NOTE**

Care must be taken to prevent solvent from entering gear box. The gear box lubricant is not affected and should not be disturbed.

h. After soaking, clean entire length of jack screw with a wire brush, rinse with solvent and dry with compressed air.

**NOTE**

Do not disassemble nut and ball retainer assembly.

i. Relubricate jack screw with MIL-G-21164 (Molybdenum Disulfide Grease) as outlined in steps "j" thru "m".

j. Rotate nut down screw toward the motor.

k. Coat screw and thread end of nut with grease and run nut to full extension.

l. Repeat the process and pack lubricant in the cavity between the nut and ball retainer at the threaded end of the nut.

m. Repeat the process and work nut back and forth several times.

n. Remove excess grease.

o. Reinstall actuator in aircraft per Section

7.

b. On aircraft prior to Serials 17259905 and F172-00805, which have been modified by Service Kit SK150-37B, proceed as follows:

1. At each 100 hour inspection, expose jack screw by operating flaps to full-down position, and inspect wing flap actuator jack screw for proper lubrication. If lubrication is required, proceed as follows:

a. Clean jack screw with solvent rag, if

necessary, and dry with compressed air.

b. Relubricate jack screw with MIL-G-21164 (Molybdenum Disulfide Grease) as required.

c. On aircraft beginning with Serials 17259905 and F17200805 and aircraft modified by Service Kit SK150-41, clean and lubricate wing flap actuator jack screw each 100 hours as follows:  
down position.

2. Clean jack screw threads with solvent rag and dry with compressed air.

**NOTE**

It is not necessary to remove actuator from aircraft to clean or lubricate threads.

3. With oil can, apply light coat of No. 10 weight, non-detergent oil to threads of jack screw.

2-44. FUEL SELECTOR VALVE. At each 100 hour inspection, check the fuel selector valve and drive shaft for the following:

a. Valve control detent plate for cleanliness and excessive wear. Dirt accumulation on this plate can cause binding, poor detent feel and rapid wear of the plate.

b. All drive shaft attach points for security, binding, excessive wear and lubrication, if required.

c. Operate valve handle through all positions and check for proper operation, detent feel and freedom of movement.

**SHOP NOTES:**

---

---

---

---

---

---

---

---

---

---

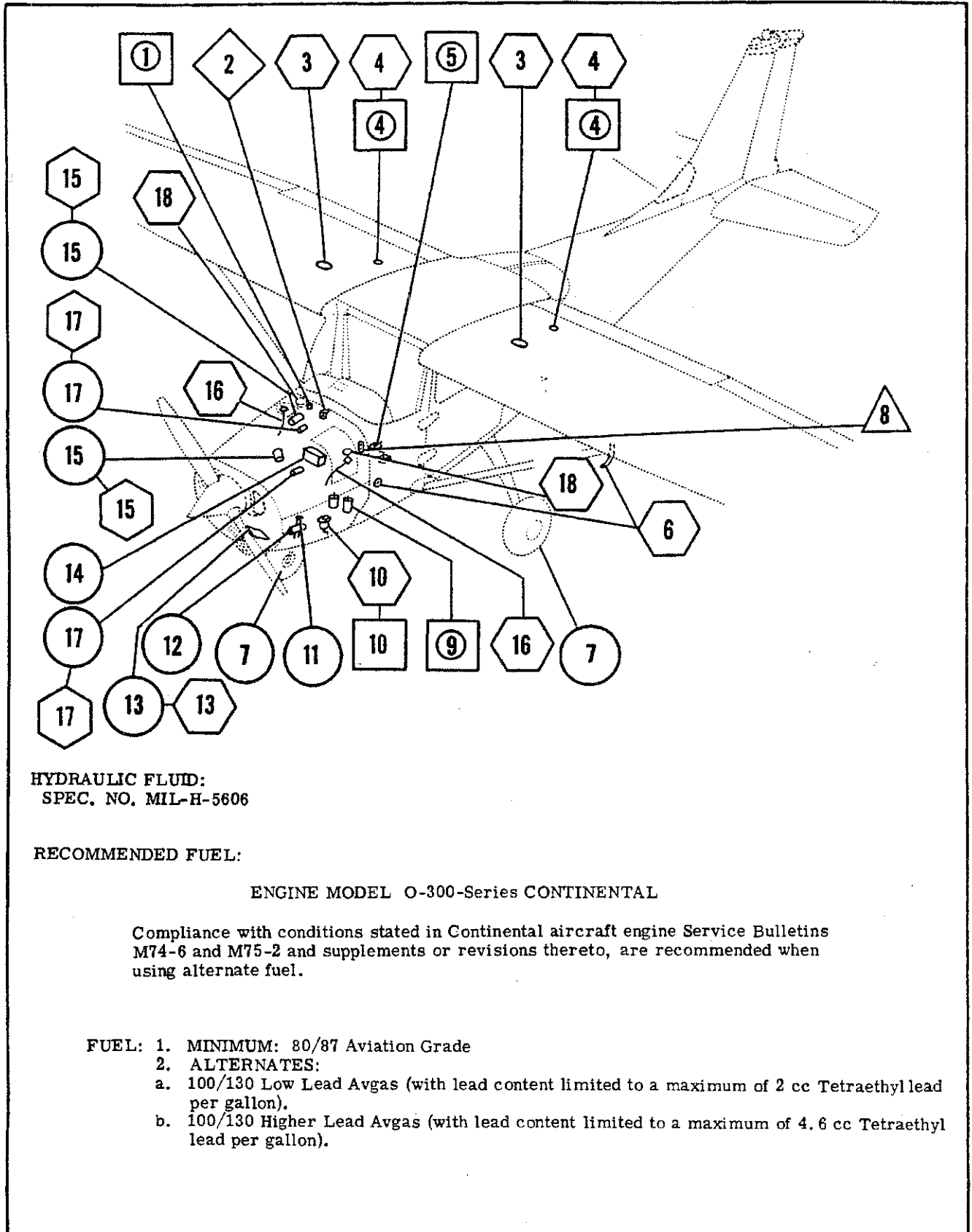

**HYDRAULIC FLUID:**  
 SPEC. NO. MIL-H-5606

**RECOMMENDED FUEL:**

**ENGINE MODEL O-300-Series CONTINENTAL**

Compliance with conditions stated in Continental aircraft engine Service Bulletins M74-6 and M75-2 and supplements or revisions thereto, are recommended when using alternate fuel.

- FUEL:**
1. MINIMUM: 80/87 Aviation Grade
  2. ALTERNATES:
    - a. 100/130 Low Lead Avgas (with lead content limited to a maximum of 2 cc Tetraethyl lead per gallon).
    - b. 100/130 Higher Lead Avgas (with lead content limited to a maximum of 4.6 cc Tetraethyl lead per gallon).

Figure 2-4. Servicing (Sheet 1 of 4)

**RECOMMENDED FUEL (Cont).**

**ENGINE MODEL O-320-E LYCOMING**

Compliance with conditions stated in the latest edition of Avco Lycoming Service Instruction No. 1070 and also in applicable Service Letters is recommended when using alternate fuel.

- FUEL:**
1. MINIMUM: 80/87 Aviation Grade
  2. ALTERNATES:
    - a. 100/130 Low Lead Avgas (with lead content limited to a maximum of 2 cc Tetraethyl lead per gallon).
    - b. 100/130 Higher Lead Avgas (with lead content limited to a maximum of 4.6 cc Tetraethyl lead per gallon).
    - c. 115/145 Aviation Grade (with lead content limited to a maximum of 4.6 cc Tetraethyl lead per gallon).

**RECOMMENDED ENGINE OIL:**

**ENGINE MODEL O-300-Series CONTINENTAL**

**AVIATION GRADE:**

ABOVE 40° F	SAE 40
BELOW 40° F	SAE 20

Aviation Grade ashless dispersant oil, conforming to Continental Motors Specification MHS-24 and all revisions and supplements thereto, must be used except as noted in paragraph 2-21. Refer to Continental Aircraft Engine Service Bulletin M74-19 and any superseding bulletins, revisions, or supplements thereto for further recommendations.

**ENGINE MODEL O-320-E LYCOMING**

**AVIATION GRADE:**

ABOVE 60° F	SAE 40 OR SAE 50
30° TO 90° F	SAE 40
0° TO 70° F	SAE 40 OR SAE 30
BELOW 10° F	SAE 30

Aviation Grade ashless dispersant oil, conforming to Lycoming Specification No. 301 and all revisions and supplements thereto must be used except as noted in paragraph 2-21. Refer to Avco Lycoming Service Instruction No. 1014E and any superseding bulletins, revisions or supplements thereto for further recommendations.

**SHOP NOTES:**

---

---

---

Figure 2-4. Servicing (Sheet 2 of 4)



### DAILY

- 3 FUEL TANK FILLER**  
Service after each flight. Keep full to retard condensation. Refer to paragraph 2-18 for details.
- 4 FUEL TANK SUMP DRAINS**  
If quick-drain valves are installed, drain off any water and sediment before first flight of the day.
- 6 PITOT AND STATIC PORTS**  
Check for obstructions before first flight of the day.
- 10 FUEL STRAINER**  
Drain off any water and sediment before the first flight of the day. Refer to paragraph 2-19 for details.
- 13 INDUCTION AIR FILTER**  
Inspect and service under dusty conditions. Refer to paragraph 2-22 for details.
- 16 OIL DIPSTICK**  
Check oil on preflight. Add oil as necessary. Refer to paragraph 2-21 for details.
- 18 OIL FILLER CAP:**  
Whenever oil is added, check that filler cap is tight and oil filler door is secure.



### FIRST 25 HOURS

- 15, 17 ENGINE OIL SYSTEM**  
Refill with straight mineral oil, non-detergent, and use until a total of 50 hours has accumulated or oil consumption has stabilized, then change to ashless dispersant oil.



### 50 HOURS

- 13 INDUCTION AIR FILTER**  
Clean filter per paragraph 2-22. Replace as required.
- 14 BATTERY**  
Check electrolyte level and clean battery compartment each 50 hours or each 30 days.
- 15 17 ENGINE OIL SYSTEM**  
Change oil each 50 hours if engine is NOT equipped with external oil filter; if equipped with external oil filter, change filter element each 50 hours and oil at each 100 hours, or every 6 months.
- 12 SHIMMY DAMPENER**  
Check fluid level and refill as required with hydraulic fluid. Refer to paragraph 2-27.
- 7 TIRES**  
Maintain correct tire pressure as listed in figure 1-1. Also refer to paragraph 2-25 for details.

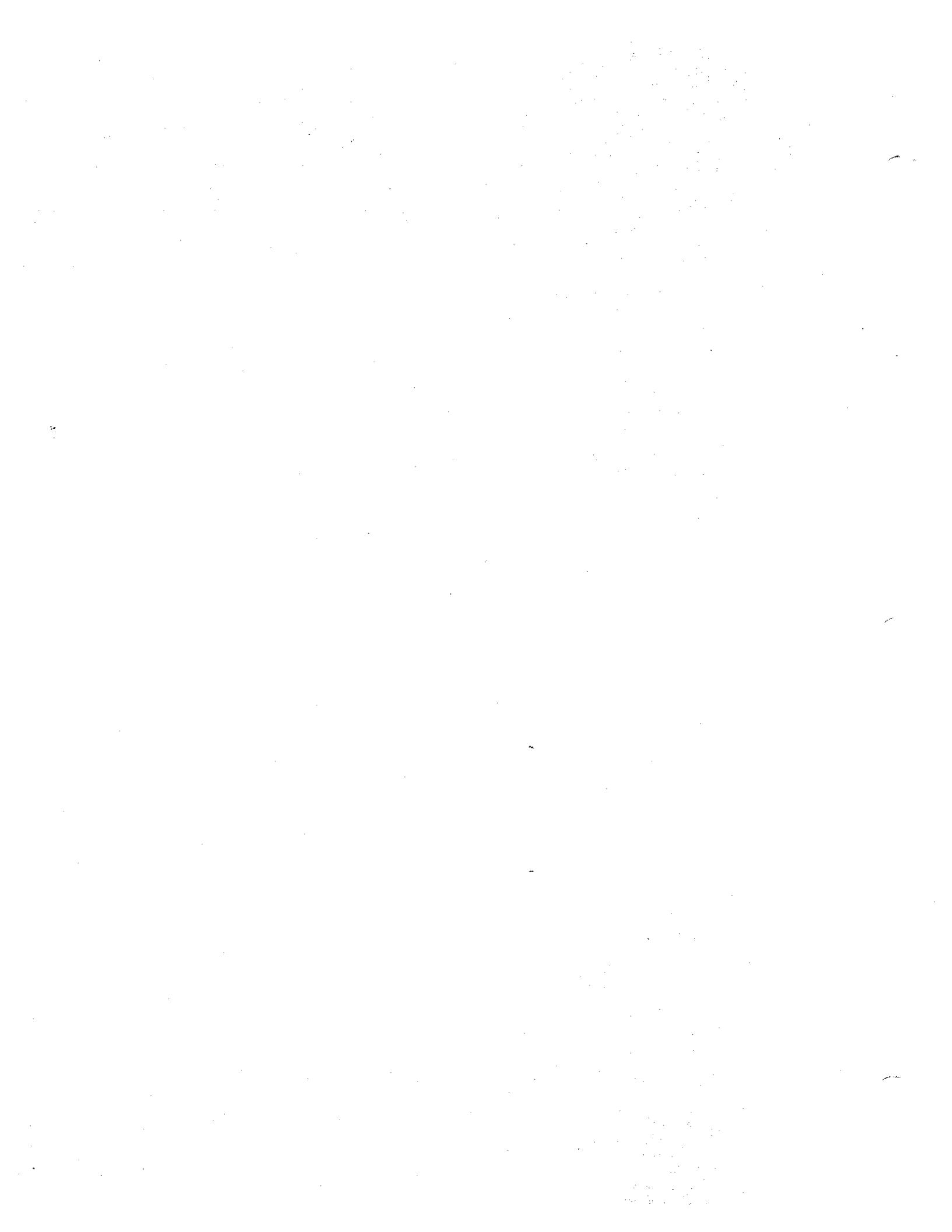



50 HOURS (Cont)

**11 NOSE GEAR SHOCK STRUT**

Keep strut filled and inflate to correct pressure. Refer to paragraph 2-26 for details.



100 HOURS

**10 FUEL STRAINER**

Disassemble and clean strainer bowl and screen.



200 HOURS

**1 VACUUM RELIEF FILTER**

Change each 1000 hours, or to coincide with engine overhauls.

**4 FUEL TANK SUMP DRAINS**

If quick-drain valves are not installed, remove plugs and drain off water or sediment. Reinstall plugs and safety. Also refer to paragraph 2-19.

**5 SELECTOR VALVE DRAIN**

Remove plug and drain off any water or sediment. Also refer to paragraph 2-19.

**9 BRAKE MASTER CYLINDERS**

Check fluid level and refill as required with hydraulic fluid. Refer to paragraph 2-28.



500 HOURS

**2 VACUUM SYSTEM CENTRAL AIR FILTER**

Replace every 500 hours.



AS REQUIRED

**8 GROUND SERVICE RECEPTACLE**

Connect to 12-volt DC, negative-ground power unit. Refer to paragraph 11-67 for details.

Figure 2-4. Servicing (Sheet 4 of 4)

FREQUENCY (HOURS)



METHOD OF APPLICATION



WHERE NO INTERVAL IS SPECIFIED, LUBRICATE AS REQUIRED AND WHEN ASSEMBLED OR INSTALLED.

NOTE

The military specifications listed are not mandatory, but are intended as guides in choosing satisfactory materials. Products of most reputable manufacturers meet or exceed these specifications.

LUBRICANTS

PG — SS-G-659	POWDERED GRAPHITE
GR — MIL-G-81322A	GENERAL PURPOSE GREASE
GH — MIL-G-23827A	AIRCRAFT AND INSTRUMENT GREASE
GL — MIL-G-21164C	MOLYBDENUM DISULFIDE GREASE
OG — MIL-L-7870A	GENERAL PURPOSE OIL
PL — VV-P-236	PETROLATUM
GS — MIL-S-8660	DC4 DOW CORNING
GP —	NO. 10-WEIGHT, NON-DETERGENT OIL

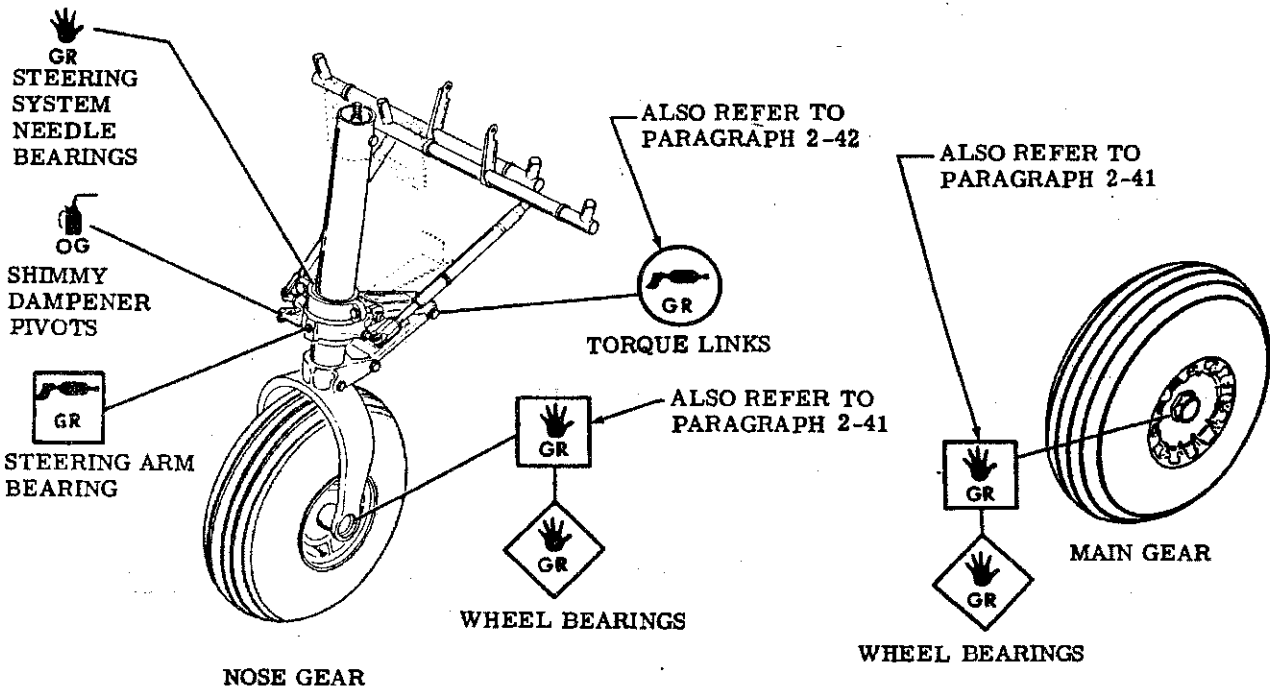

Figure 2-5. Lubrication (Sheet 1 of 3)



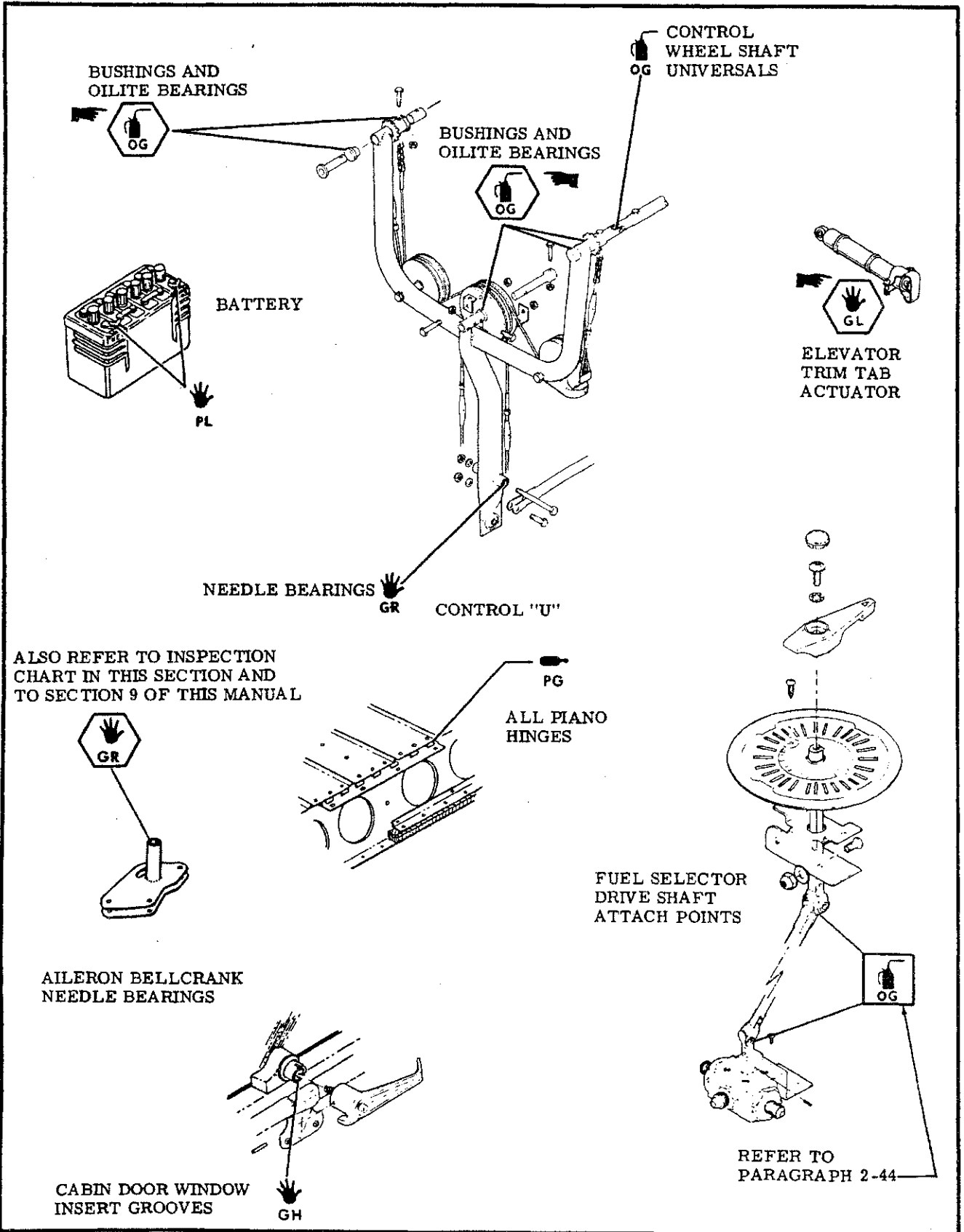
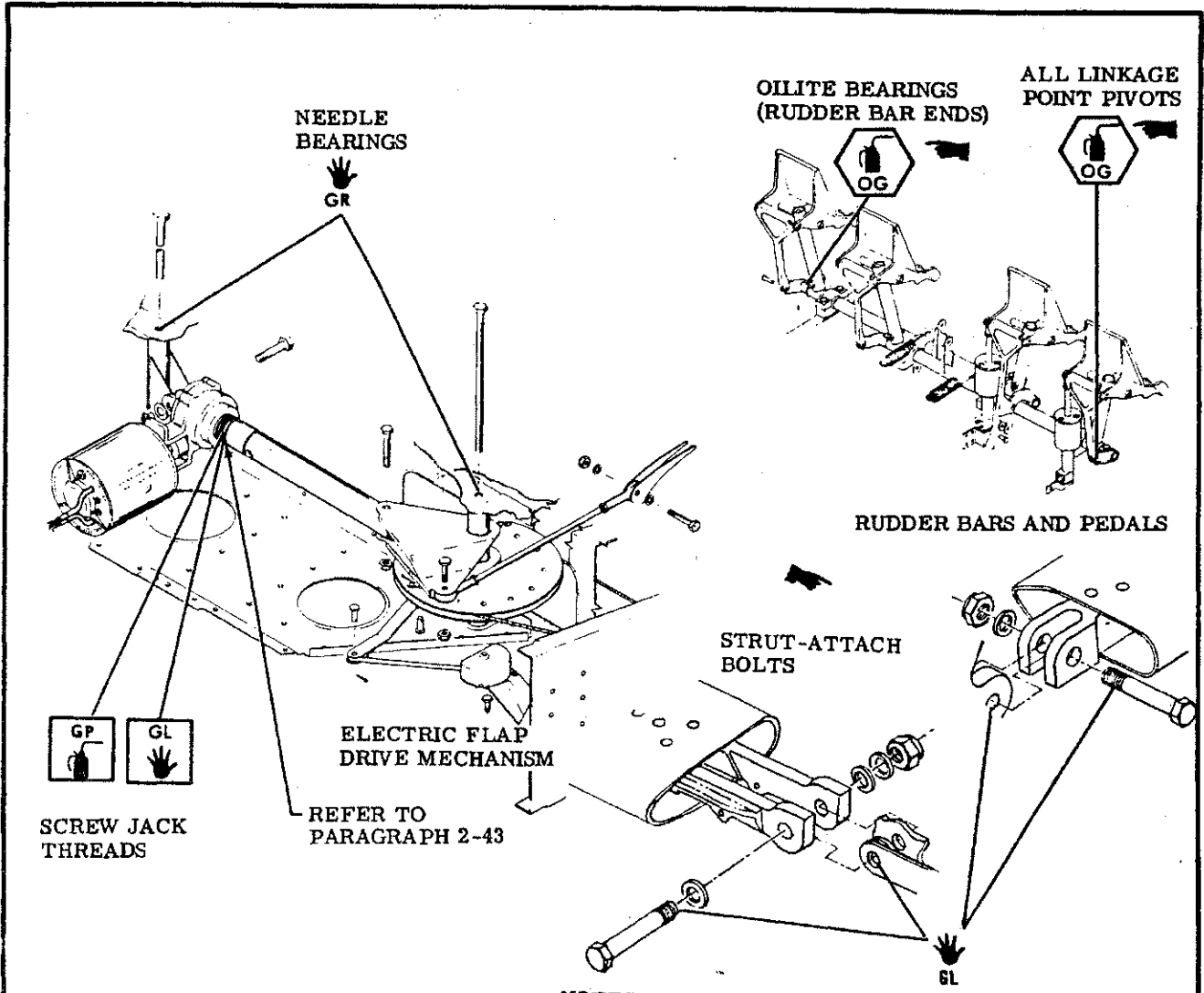

Figure 2-5. Lubrication (Sheet 2 of 3)



NOTES

- Sealed bearings require no lubrication.
- Do not lubricate roller chains or cables except under seacoast conditions. Wipe with a clean, dry cloth.
- Lubricate unsealed pulley bearings, rod ends, Oilite bearings, pivot and hinge points, and any other friction point obviously needing lubrication, with general purpose oil every 1000 hours or oftener if required.
- Paraffin wax rubbed on seat rails will ease sliding the seats fore and aft.
- Lubricate door latching mechanism with MIL-G-81322A general purpose grease, applied sparingly to friction points, every 1000 hours or oftener, if binding occurs. No lubrication is recommended on the rotary clutch.

Figure 2-5. Lubrication (Sheet 3 of 3)

## I INSPECTION REQUIREMENTS.

As required by Federal Aviation Regulations, all civil aircraft of U. S. registry must undergo a complete inspection (annual) each twelve calendar months. In addition to the required ANNUAL inspection, aircraft operated commercially (for hire) must also have a complete aircraft inspection every 100 hours of operation.

In lieu of the above requirements, an aircraft may be inspected in accordance with a progressive inspection schedule, which allows the work load to be divided into smaller operations that can be accomplished in shorter time periods.

Therefore, the Cessna Aircraft Company recommends PROGRESSIVE CARE for aircraft that are being flown 200 hours or more per year, and the 100 HOUR inspection for all other aircraft.

## II INSPECTION CHARTS.

The following charts show the recommended intervals at which items are to be inspected.

As shown in the charts, there are items to be checked each 50 hours, each 100 hours, each 200 hours, and also Special Inspection items which require servicing or inspection at intervals other than 50, 100 or 200 hours.

- a. When conducting an inspection at 50 hours, all items marked under EACH 50 HOURS would be inspected, serviced or otherwise accomplished as necessary to insure continuous airworthiness.
- b. At each 100 hours, the 50 hour items would be accomplished in addition to the items marked under EACH 100 HOURS as necessary to insure continuous airworthiness.
- c. An inspection conducted at 200 hour intervals would likewise include the 50 hour items and 100 hour items in addition to those at EACH 200 HOURS.
- d. The numbers appearing in the SPECIAL INSPECTION ITEMS column refer to data listed at the end of the inspection charts. These items should be checked at each inspection interval to insure that applicable servicing and inspection requirements are accomplished at the specified intervals.
- e. A complete aircraft inspection includes all 50, 100 and 200 hour items plus those Special Inspection Items which are due at the time of the inspection.

## III INSPECTION PROGRAM SELECTION.

### **AS A GUIDE FOR SELECTING THE INSPECTION PROGRAM THAT BEST SUITS THE OPERATION OF THE AIRCRAFT, THE FOLLOWING IS PROVIDED.**

#### **I. IF THE AIRCRAFT IS FLOWN LESS THAN 200 HOURS ANNUALLY.**

##### **a. IF FLOWN FOR HIRE**

An aircraft operating in this category must have a complete aircraft inspection each 100 hours and each 12 calendar months of operation. A complete aircraft inspection consists of all 50, 100, 200 and Special Inspection Items shown in the inspection charts as defined in paragraph II above.

##### **b. IF NOT FLOWN FOR HIRE**

An aircraft operating in this category must have a complete aircraft inspection each 12 calendar months (ANNUAL). A complete aircraft inspection consists of all 50, 100, 200 and Special Inspection Items shown in the inspection charts as defined in paragraph II above. In addition, it is recommended that between annual inspections, all items be inspected at the intervals specified in the inspection charts.

**2. IF THE AIRCRAFT IS FLOWN MORE THAN 200 HOURS ANNUALLY.**

Whether flown for hire or not, it is recommended that aircraft operating in this category be placed on the CESSNA PROGRESSIVE CARE PROGRAM. However, if not placed on Progressive Care, the inspection requirements for aircraft in this category are the same as those defined under paragraph III 1. (a) and (b).

Cessna Progressive Care may be utilized as a total concept program which insures that the inspection intervals in the inspection charts are not exceeded. Manuals and forms which are required for conducting Progressive Care inspections are available from the Cessna Service Parts Center.

**IV INSPECTION GUIDE LINES.**

- (a) **MOVABLE PARTS** for: lubrication, servicing, security of attachment, binding, excessive wear, safetying, proper operation, proper adjustment, correct travel, cracked fittings, security of hinges, defective bearings, cleanliness, corrosion, deformation, sealing and tension.
- (b) **FLUID LINES AND HOSES** for: leaks, cracks, dents, kinks, chafing, proper radius, security, corrosion, deterioration, obstruction and foreign matter.
- (c) **METAL PARTS** for: security of attachment, cracks, metal distortion, broken spotwelds, corrosion, condition of paint and any other apparent damage.
- (d) **WIRING** for: security, chafing, burning, defective insulation, loose or broken terminals, heat deterioration and corroded terminals.
- (e) **BOLTS IN CRITICAL AREAS** for: correct torque in accordance with torque values given in the chart in Section 1, when installed or when visual inspection indicates the need for a torque check.

**NOTE**

Torque values listed in Section 1 are derived from oil-free cadmium-plated threads, and are recommended for all installation procedures contained in this book except where other values are stipulated. They are not to be used for checking tightness of installed parts during service.

- (f) **FILTERS, SCREENS & FLUIDS** for: cleanliness, contamination and/or replacement at specified intervals.
- (g) **AIRCRAFT FILE.**

Miscellaneous data, information and licenses are a part of the aircraft file. Check that the following documents are up-to-date and in accordance with current Federal Aviation Regulations. Most of the items listed are required by the United States Federal Aviation Regulations. Since the regulations of other nations may require other documents and data, owners of exported aircraft should check with their own aviation officials to determine their individual requirements.

To be displayed in the aircraft at all times:

- 1. Aircraft Airworthiness Certificate (FAA Form 8100-2).
- 2. Aircraft Registration Certificate (FAA Form 8050-3).
- 3. Aircraft Radio Station License, if transmitter is installed (FCC Form 556).

To be carried in the aircraft at all times:

- 1. Weight and Balance, and associated papers (Latest copy of the Repair and Alteration Form, FAA Form 337, if applicable).
- 2. Aircraft Equipment List.

To be made available upon request:

- 1. Aircraft Log Book and Engine Log Book.

(h) ENGINE RUN-UP.

Before beginning the step-by-step inspection, start, run up and shut down the engine in accordance with instructions in the Owner's Manual. During the run-up, observe the following, making note of any discrepancies or abnormalities:

1. Engine temperatures and pressures.
2. Static rpm. (Also refer to Section 11 or 11A of this Manual.)
3. Magneto drop. (Also refer to Section 11 or 11A of this Manual.)
4. Engine response to changes in power.
5. Any unusual engine noises.
6. Fuel selector and/or shut-off valve; operate engine(s) on each tank (or cell) position and OFF position long enough to ensure shut-off and/or selector valve functions properly.
7. Idling speed and mixture; proper idle cut-off.
8. Alternator and ammeter.
9. Suction gage.
10. Fuel flow indicator.

After the inspection has been completed, an engine run-up should again be performed to determine that any discrepancies or abnormalities have been corrected.

**SHOP NOTES:**

---

---

---

---

---

---

---

---



SPECIAL INSPECTION ITEM			
	EACH 200 HOURS	EACH 100 HOURS	EACH 50 HOURS
22. Starter brushes, brush leads and commutator . . . . .			●
23. Alternator and electrical connections . . . . .		●	
24. Alternator brushes, brush leads, commutator or slip rings . . . . .		●	7
25. Voltage regulator mounting and electrical leads . . . . .		●	
26. Magnetos (externally) and electrical connections . . . . .		●	
27. Magneto timing . . . . .		●	8
28. Carburetor and drain plug . . . . .		●	
29. Firewall . . . . .			●
30. Engine cowling . . . . .	●		
<b>FUEL SYSTEM</b>			
1. Fuel strainer, drain valve and control . . . . .		●	
2. Fuel strainer screen and bowl . . . . .		●	
3. Fuel tank vents, caps and placards . . . . .		●	
4. Fuel tanks, sump drains and fuel line drains . . . . .			●
5. Drain fuel and check tank interior, attachment and outlet screens . . . . .			5
6. Fuel vent valves . . . . .		●	
7. Fuel vent line drain . . . . .		●	
8. Fuel selector valve and placards . . . . .	●		
9. Fuel valve drain plug . . . . .			●
10. Engine primer . . . . .		●	
<b>LANDING GEAR</b>			
1. Main gear wheels and fairings . . . . .		●	
2. Nose gear wheel, torque links, steering rods, boots and fairing . . . . .		●	
3. Wheel bearings . . . . .			●
4. Nose gear strut and shimmy dampener (service as required) . . . . .		●	
5. Tires . . . . .		●	
6. Brake fluid, lines and hoses, linings, discs, brake assemblies and master cylinders . . . . .			●
7. Parking brake system . . . . .			●

- 22. Starter brushes, brush leads and commutator . . . . .
- 23. Alternator and electrical connections . . . . .
- 24. Alternator brushes, brush leads, commutator or slip rings . . . . .
- 25. Voltage regulator mounting and electrical leads . . . . .
- 26. Magnetos (externally) and electrical connections . . . . .
- 27. Magneto timing . . . . .
- 28. Carburetor and drain plug . . . . .
- 29. Firewall . . . . .
- 30. Engine cowling . . . . .

**FUEL SYSTEM**

- 1. Fuel strainer, drain valve and control . . . . .
- 2. Fuel strainer screen and bowl . . . . .
- 3. Fuel tank vents, caps and placards . . . . .
- 4. Fuel tanks, sump drains and fuel line drains . . . . .
- 5. Drain fuel and check tank interior, attachment and outlet screens . . . . .
- 6. Fuel vent valves . . . . .
- 7. Fuel vent line drain . . . . .
- 8. Fuel selector valve and placards . . . . .
- 9. Fuel valve drain plug . . . . .
- 10. Engine primer . . . . .

**LANDING GEAR**

- 1. Main gear wheels and fairings . . . . .
- 2. Nose gear wheel, torque links, steering rods, boots and fairing . . . . .
- 3. Wheel bearings . . . . .
- 4. Nose gear strut and shimmy dampener (service as required) . . . . .
- 5. Tires . . . . .
- 6. Brake fluid, lines and hoses, linings, discs, brake assemblies and master cylinders . . . . .
- 7. Parking brake system . . . . .

SPECIAL INSPECTION ITEM

EACH 200 HOURS

EACH 100 HOURS

EACH 50 HOURS

- 8. Main gear springs . . . . .
- 9. Steering arm lubrication . . . . .
- 10. Torque link lubrication . . . . .
- 11. Park brake and toe brakes - operational check . . . . .

AIRFRAME

- 1. Aircraft exterior . . . . .
- 2. Aircraft structure . . . . .
- 3. Windows, windshield, doors and seals . . . . .
- 4. Seat belts and shoulder harnesses . . . . .
- 5. Seat stops, seat rails, upholstery, structure and mounting . . . . .
- 6. Control "U" bearings, sprockets, pulleys, cables, chains and turnbuckles . . . . .
- 7. Control lock, control wheel and control "U" mechanism . . . . .
- 8. Instruments and markings . . . . .
- 9. Gyros central air filter . . . . .
- 10. Magnetic compass compensation . . . . .
- 11. Instrument wiring and plumbing . . . . .
- 12. Instrument panel, shockmounts, ground straps, cover, decals and labeling . . . . .
- 13. Defrosting, heating and ventilating systems and controls . . . . .
- 14. Cabin upholstery, trim, sunvisors and ash trays . . . . .
- 15. Area beneath floor, lines, hoses, wires and control cables . . . . .
- 16. Lights, switches, circuit breakers, fuses and spare fuses . . . . .
- 17. Exterior lights . . . . .
- 18. Pitot and static systems . . . . .
- 19. Stall warning system . . . . .
- 20. Radios, radio controls, avionics and flight instruments . . . . .
- 21. Antennas and cables . . . . .
- 22. Battery, battery box and battery cables . . . . .
- 23. Battery electrolyte . . . . .
- 24. Emergency locator transmitter . . . . .

10  
5

11  
12





## SPECIAL INSPECTION ITEMS

- 5 Each 1000 hours, or to coincide with engine overhauls.
- 6 Each 50 hours for general condition and freedom of movement. These controls are not repairable. Replace as required at each engine overhaul.
- 7 Each 500 hours
- 8 (LYCOMING "BLUE STREAK")  
INTERNAL TIMING: These magnetos cannot be overhauled in the field. The coil, capacitor and breaker assembly are non-replaceable. As a good maintenance practice, and to have the benefit of good ignition at all times, it is recommended that the magnetos be removed at 900 hours of magneto time, and install new exchange magnetos.  
  
MAGNETO-TO-ENGINE TIMING: First 50 hours, first 100 hours and each 200 hours thereafter.  
  
ROLLS/ROYCE CONTINENTAL  
INTERNAL TIMING: As long as internal timing and magneto-to-engine timing are within the prescribed limits, it is recommended that magneto be checked internally only at 500 hour intervals.  
  
MAGNETO-TO-ENGINE TIMING: Each 100 hours.
- 9 First 100 hours and each 500 hours thereafter. More often if operated under prevailing wet or dusty conditions.
- 10 Replace each 500 hours.
- 11 Check electrolyte level and clean battery compartment each 50 hours or each 30 days.
- 12 Refer to Section 16 of this Manual.
- 13 Lubrication is required of the actuator each 1000 hours and/or 3 years, whichever comes first. Refer to figure 2-5 for grease specification.  
  
Refer to Section 9 of this Manual for free-play limits, inspection, replacement and/or repair.
- 14 Refer to paragraph 2-43 for detailed instructions for various serial ranges.
- 15 A "one-time" dye penetrant inspection of blades of Model IC172/MTM7653 propellers should be performed in accordance with Service Letter SE 70-31 (supplement #1). This inspection should be accomplished within the next 25 hours of operation if this Service Letter has not been complied with.

### NOTE

A high-time inspection is merely a 100-hour inspection with the addition of an engine overhaul. Continental recommends engine overhaul at 1800 hours for the O-300-series engine, except as stipulated in Continental aircraft engine Service Bulletin #M74-20 and supplements thereto. Lycoming recommends engine overhaul at 2000 hours for the O-320-series engine except as stipulated in Avco Lycoming Service Instruction No. 1009 and revisions thereto. At the time of overhaul, engine accessories should be overhauled.

SECTION 3

FUSELAGE

TABLE OF CONTENTS

	Page		
FUSELAGE . . . . .	3-1	Reclining Back . . . . .	3-8
Windshield and Windows . . . . .	3-1	Vertical Adjust/Reclining Back . . . . .	3-8
Description . . . . .	3-1	Articulating Recline/Vertical	
Cleaning . . . . .	3-1	Adjust . . . . .	3-8
Waxing . . . . .	3-1	Description . . . . .	3-8
Repairs . . . . .	3-1	Removal and Installation . . . . .	3-8
Scratches . . . . .	3-1	Center . . . . .	3-8
Cracks . . . . .	3-2	Double-Width Bottom and Back/	
Windshield . . . . .	3-4	Single Reclining Back . . . . .	3-8
Removal . . . . .	3-4	Double-Width Bottom and Back/	
Installation . . . . .	3-4	Individual Reclining Backs . . . . .	3-8
Windows . . . . .	3-4	Description . . . . .	3-8
Movable . . . . .	3-4	Removal and Installation . . . . .	3-8
Removal and Installation . . . . .	3-4	Auxiliary . . . . .	3-8
Wrap-Around Rear . . . . .	3-4	Fold-Up . . . . .	3-8
Removal and Installation . . . . .	3-4	Description . . . . .	3-8
Overhead . . . . .	3-4	Removal and Installation . . . . .	3-8
Removal and Installation . . . . .	3-4	Repair . . . . .	3-8
Fixed . . . . .	3-4	Cabin Upholstery . . . . .	3-8
Cabin Doors . . . . .	3-4	Materials and Tools . . . . .	3-8
Removal and Installation . . . . .	3-4	Soundproofing . . . . .	3-8
Adjustment . . . . .	3-4	Cabin Headliner . . . . .	3-8
Weatherstrip . . . . .	3-4	Removal and Installation . . . . .	3-8
Latches . . . . .	3-4	Upholstery Side Panels . . . . .	3-17
Description . . . . .	3-4	Carpeting . . . . .	3-17
Adjustment . . . . .	3-5	Safety Provisions . . . . .	3-17
Lock . . . . .	3-5	Cargo Tie-Downs . . . . .	3-17
Indexing Inside Handle . . . . .	3-6A	Safety Belts . . . . .	3-18
Baggage Door . . . . .	3-6A	Shoulder Harness . . . . .	3-18
Removal and Installation . . . . .	3-6A	Glider Tow Hook . . . . .	3-18
Seats . . . . .	3-8	Rear View Mirror . . . . .	3-18
Pilot and Copilot . . . . .	3-8		

3-1. FUSELAGE.

3-2. WINDSHIELD AND WINDOWS.

3-3. DESCRIPTION. The windshield and windows are single-piece acrylic plastic panels set in sealing strips and held by formed retaining strips secured to the fuselage with screws and rivets. Presstite No. 579.6 sealing compound used in conjunction with a felt seal is applied to all edges of the windshield and windows with exception of wing root area. The wing root fairing has a heavy felt strip that completes the windshield sealing.

3-4. CLEANING. (Refer to Section 2.)

3-5. WAXING. Waxing will fill in minor scratches in clear plastic and help protect the surface from further abrasion. Use a good grade of commercial wax applied in a thin, even coat. Bring wax to a high polish by rubbing lightly with a clean, dry flannel cloth.

3-6. REPAIRS. Damaged window panels and wind-

shield may be removed and replaced if damage is extensive. However, certain repairs as prescribed in the following paragraphs can be made successfully without removing damaged part from aircraft. Three types of temporary repairs for cracked plastic are possible. No repairs of any kind are recommended on highly-stressed or compound curves where repair would be likely to affect pilot's field of vision. Curved areas are more difficult to repair than flat areas and any repaired area is both structurally and optically inferior to the original surface.

3-7. SCRATCHES. Scratches on clear plastic surfaces can be removed by hand-sanding operations followed by buffing and polishing, if steps below are followed carefully.

a. Wrap a piece of No. 320 (or finer) sandpaper or abrasive cloth around a rubber pad or wood block. Rub surface around scratch with a circular motion, keeping abrasive constantly wet with clean water to prevent scratching surface further. Use minimum pressure and cover an area large enough to prevent formation of "bull's-eyes" or other optical distortions.

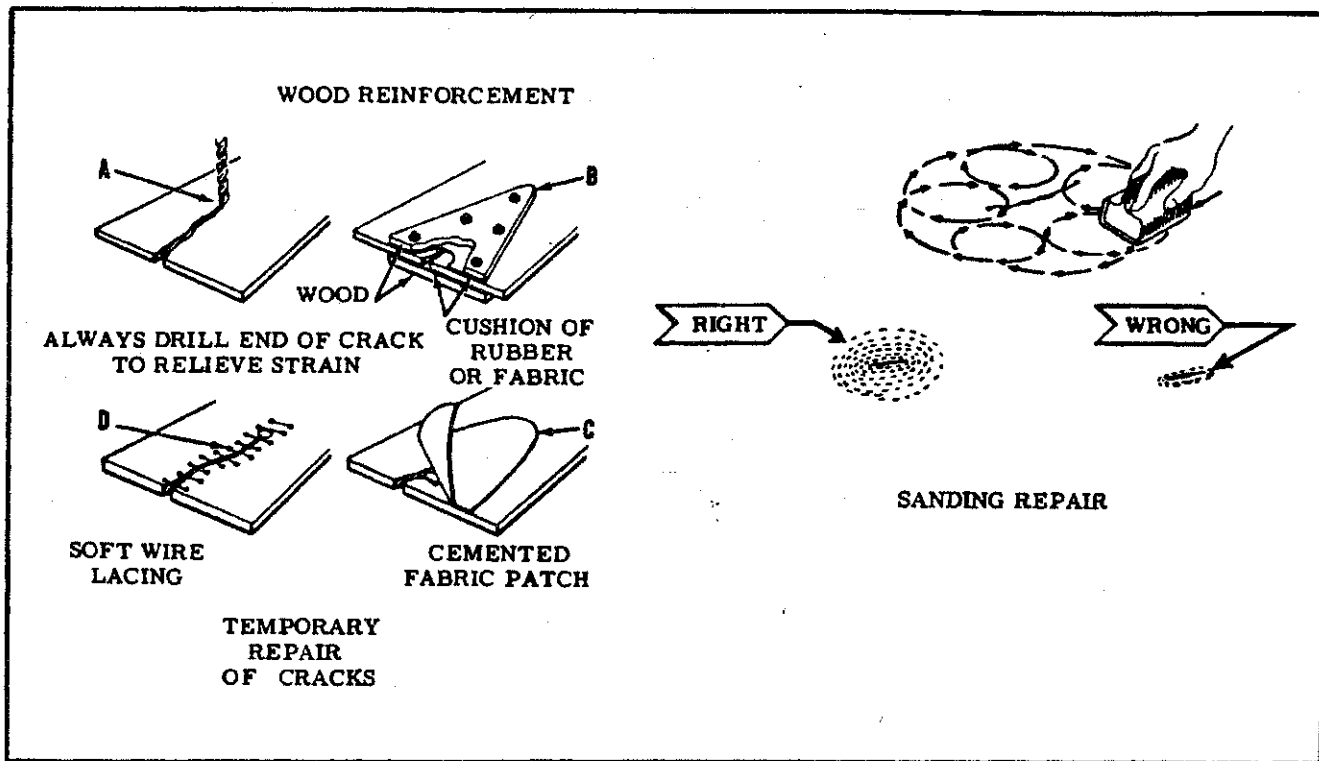

Figure 3-1. Repair of Windshield and Windows

**CAUTION**

Do not use a coarse grade of abrasive. No. 320 is of maximum coarseness.

b. Continue sanding operation, using progressively finer grade abrasives until scratches disappear.

c. When scratches have been removed, wash area thoroughly with clean water to remove all gritty particles. The entire sanded area will be clouded with minute scratches which must be removed to restore transparency.

d. Apply fresh tallow or buffing compound to a motor-driven buffing wheel. Hold wheel against plastic surface, moving it constantly over damaged area until cloudy appearance disappears. A 2000-foot-per-minute surface speed is recommended to prevent overheating and distortion. (Example: 750 rpm polishing machine with a 10 inch buffing bonnet.)

**NOTE**

Polishing can be accomplished by hand but will require a considerably longer period of time to attain the same result as produced by a buffing wheel.

e. When buffing is finished, wash area thoroughly and dry with a soft flannel cloth. Allow surface to cool and inspect area to determine if full transparency has been restored. Apply a thin coat of hard wax and polish surface lightly with a clean flannel cloth.

**NOTE**

Rubbing plastic surface with a dry cloth will build up an electrostatic charge which attracts dirt particles and may eventually cause scratching of surface. After wax has hardened, dissipate this charge by rubbing surface with a slightly damp chamois. This will also remove dust particles which have collected while wax is hardening.

f. Minute hairline scratches can often be removed by rubbing with commercial automobile body cleaner or fine-grade rubbing compound. Apply with a soft, clean, dry cloth or imitation chamois.

**3-8. CRACKS.** (Refer to figure 3-1.)

a. When a crack appears, drill a hole at end of crack to prevent further spreading. Hole should be approximately 1/8 inch in diameter, depending on length of crack and thickness of material.

b. Temporary repairs to flat surfaces can be accomplished by placing a thin strip of wood over each side of surface and inserting small bolts through wood and plastic. A cushion of sheet rubber or aircraft fabric should be placed between wood and plastic on both sides.

c. A temporary repair can be made on a curved surface by placing fabric patches over affected areas. Secure patches with aircraft dope, Specification No. MIL-D-5549, or lacquer, Specification No. MIL-L-7178. Lacquer thinner, Specification No. MIL-T-6094 can also be used to secure patch.

**NOTE**

Prestite No. 579.6 sealer and EC-1202 reinforced tape sealant should be applied to overhead cabin windows.  
 AIRCRAFT SERIALS 17259224 AND ON AND F17200755 AND ON

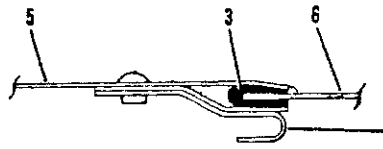

**Detail B**

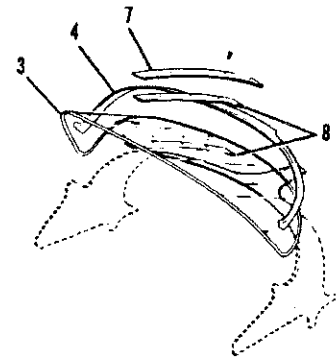

**Detail C**

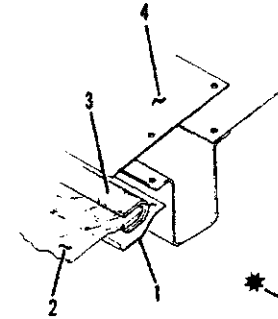

**Detail A**

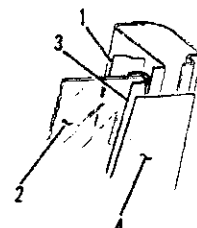

**Detail D**

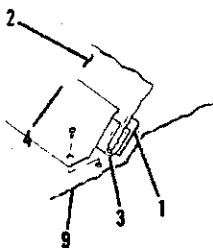

**Detail F**

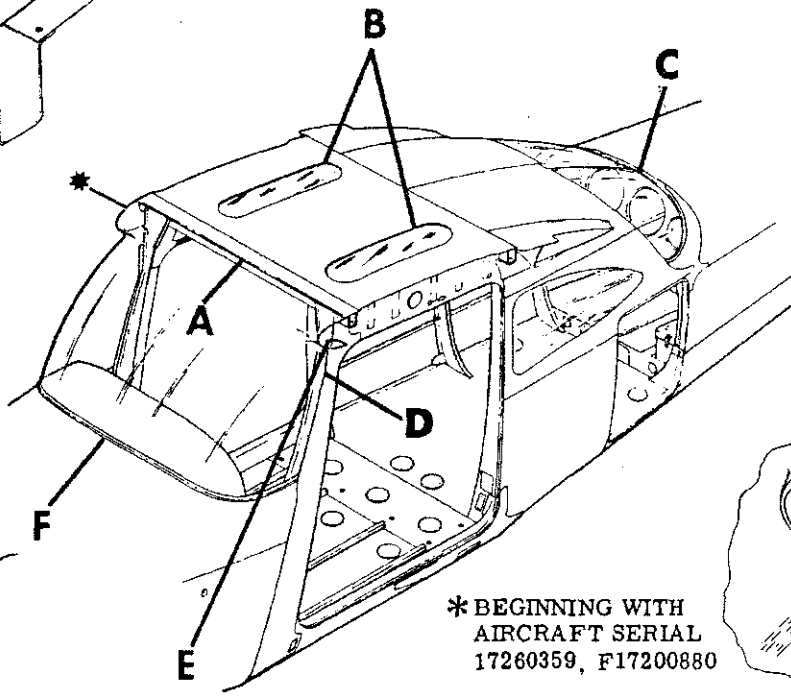

\* BEGINNING WITH AIRCRAFT SERIAL 17260359, F17200880

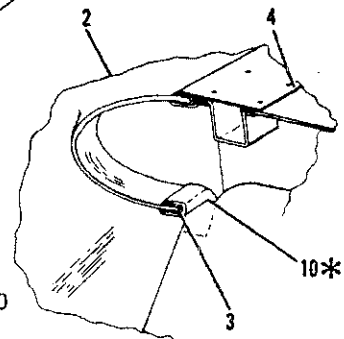

**Detail E**

**NOTE**

Presstite No. 579.6 sealer should be applied to all edges of windshield and windows when felt sealing strip (3) is used.

**NOTE**

\* Seal between windshield and fairing from front doorpost with black cloth industrial tape 2.75 inches wide, Tuck brand No. 90W 2.75 inches wide, Luch brand No. 353 2.75 inches wide or Polyken No. 214 2.17 inches wide.

- 1. Inner Retainer
- 2. Windshield
- 3. Felt Seal
- 4. Outer Retainer
- 5. Cabin Top Skin
- 6. Overhead Cabin Window
- 7. External Centerstrip
- 8. Rear Window Sealer
- 9. Fuselage Structure
- 10. Cover
- 11. Fixed Window

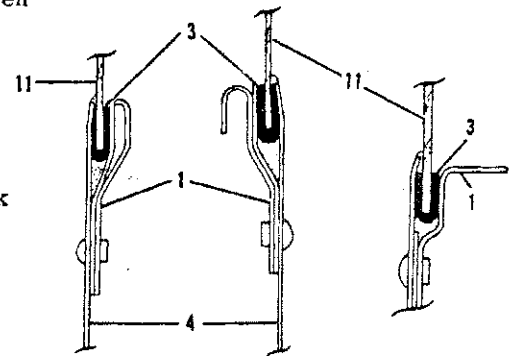

**TYPICAL METHODS OF RETAINING FIXED WINDOWS**

Figure 3-2. Windshield and Fixed Window Installation

d. A temporary repair can be made by drilling small holes along both sides of crack 1/4 to 1/8 inch apart and lacing edges together with soft wire. Small-stranded antenna wire makes a good temporary lacing material. This type of repair is used as a temporary measure ONLY, and as soon as facilities are available, panel should be replaced.

3-9. WINDSHIELD. (Refer to figure 3-2.)

3-10. REMOVAL.

- a. Drill out rivets securing front retainer strip.
- b. Remove wing fairings over windshield edges.
- c. Pull windshield straight forward, out of side and top retainers. Remove top retainer if necessary.

3-11. INSTALLATION.

- a. Apply felt strip and sealing compound or sealing tape to all edges of windshield to prevent leaks.
- b. Reverse steps in preceding paragraph for installation.
- c. When installing a new windshield, check fit and carefully file or grind away excess plastic.
- d. Use care not to crack windshield when installing. If not previously removed, top retainer may be removed if necessary. Starting at upper corner and gradually working windshield into position is recommended.

#### NOTE

Screws and self-locking nuts may be used instead of rivets which fasten front retaining strip to cowl deck. If at least No. 6 screws are used, no loss of strength will result.

3-12. WINDOWS.

3-13. MOVABLE. (Refer to figure 3-3.) A movable window, hinged at the top, is installed in the left cabin door.

3-14. REMOVAL AND INSTALLATION.

- a. Disconnect window stop (5).
- b. Remove pins from window hinges (6).
- c. Reverse preceding steps for installation. To remove frame from plastic panel, drill out blind rivets at frame splice. When replacing plastic panel in frame, ensure sealing strip and an adequate coating of Presstite No. 579.6 sealing compound is used around all edges of panel.

3-15. WRAP-AROUND REAR. (Refer to figure 3-2.) The rear window is a one-piece acrylic plastic panel set in sealing strips and held in place by retaining strips.

3-16. REMOVAL AND INSTALLATION.

- a. Remove external centerstrip (7).
- b. Remove upholstery as necessary to expose retainer strips inside cabin.
- c. Drill out rivets as necessary to remove outer retainer strip along aft edge of window.
- d. Remove window by lifting aft edge and pulling window aft. If difficulty is encountered, rivets securing retainer strips inside cabin may also be

drilled out and retainer strips loosened or removed.

e. Reverse preceding steps for installation. Apply felt strip and sealing compound to all edges of window to prevent leaks. Check fit and carefully file or grind away excess plastic. Use care not to crack plastic when installing.

3-17. OVERHEAD. (Refer to figure 3-2.) Overhead cabin windows, located in the cabin top, may be installed. These windows are one-piece acrylic plastic panels set in sealing strips and held in place by retaining strips.

3-18. REMOVAL AND INSTALLATION.

- a. Remove headliner and trim panels.
- b. Drill out rivets as necessary to remove retainer strips.
- c. Reverse preceding steps for installation. Apply felt strip and sealing compound to all edges of window to prevent leaks. Check fit and carefully file or grind away excess plastic. Use care not to crack plastic when installing.

3-19. FIXED. (Refer to figure 3-2.) Fixed windows, mounted in sealing strips and sealing compound, are held in place by various retainer strips. To replace side windows, remove upholstery and trim panels as necessary and drill out rivets securing retainers. Apply felt strip and sealing compound to all edges of window to prevent leaks. Check fit and file or grind away excess plastic. Use care not to crack plastic when installing.

3-20. CABIN DOORS. (Refer to figure 3-3.)

3-21. REMOVAL AND INSTALLATION. Removal is accomplished either by removing screws which attach the hinges or by removing hinge pins. If permanent hinge pins are removed, they may be replaced by clevis pins secured with cotter pins or new hinge pins may be installed and "spin-bradded." When fitting a new door, some trimming of the door skin and some reforming with a soft mallet may be necessary to achieve a good fit. Reforming of the bonded door is not permissible as reforming could cause damage to the bonded area.

3-22. ADJUSTMENT. Cabin doors should be adjusted so skin fairs with fuselage skin. Slots at latch plate permit re-positioning of striker plate. Depth of latch engagement may be changed by adding or removing washers or shims between striker plate and doorpost.

3-23. WEATHERSTRIP. A weatherstrip is cemented around all edges of the door. New weatherstrip may be applied after mating surfaces of weatherstrip and door are clean, dry and free from oil or grease. Apply a thin, even coat of adhesive to each surface and allow to dry until tacky before pressing strip in place. Minnesota Mining and Manufacturing Co. No. EC-800 cement is recommended.

3-24. LATCHES. (Refer to figure 3-4.)

3-25. DESCRIPTION. The cabin door latch is a push-pull bolt type, utilizing a rotary clutch for posi-

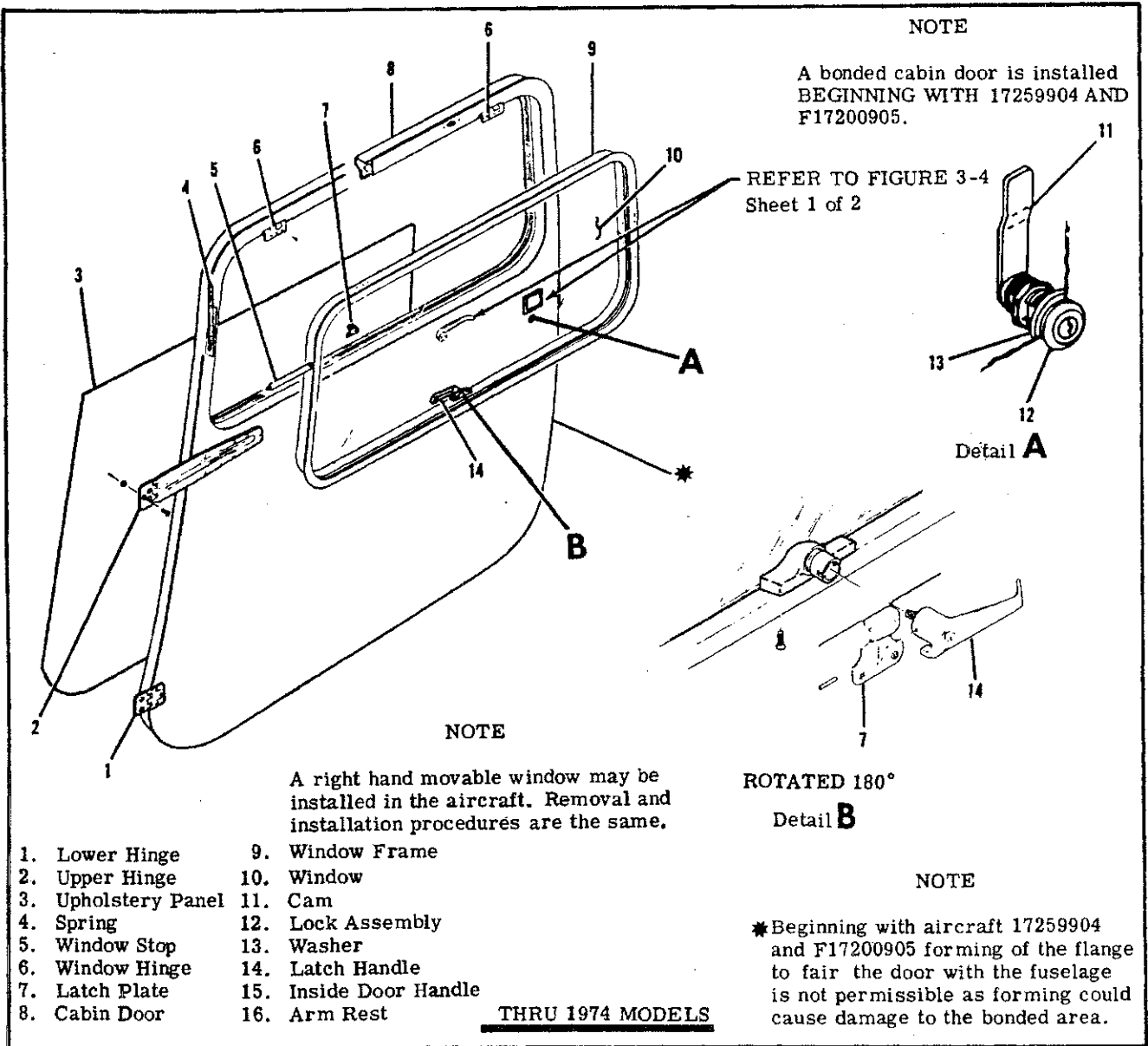

Figure 3-3. Cabin Door Installation (Sheet 1 of 2)

tive bolt engagement. As door is closed, teeth on underside of bolt engage gear teeth on clutch. The clutch gear rotates in one direction only and holds door until handle is moved to LOCK position, driving bolt into slot.

3-26. ADJUSTMENT. Adjustment of latch or clutch cover is afforded by oversize and/or slotted holes. This adjustment ensures sufficient gear-to-bolt engagement and proper alignment.

NOTE

Lubricate door latch per Section 2. No lubrication is recommended for rotary clutch.

3-27. LOCK. In addition to interior locks, a cylinder and key type lock is installed on left door. If lock is to be replaced, the new one may be modified to accept the original key. This is desirable, as the same key is used for ignition switch and cabin door lock. After removing old lock from door, proceed as follows:

- a. Remove lock cylinder from new housing.
- b. Insert original key into new cylinder and file off any protruding tumblers flush with cylinder. Without removing key, check that cylinder rotates freely in housing.
- c. Install lock assembly in door and check lock operation with door open.
- d. Destroy new key and disregard code number on cylinder.

BEGINNING WITH SERIALS  
17263459 AND F17201235

Refer To Figure 3-4  
Sheet 2 of 2

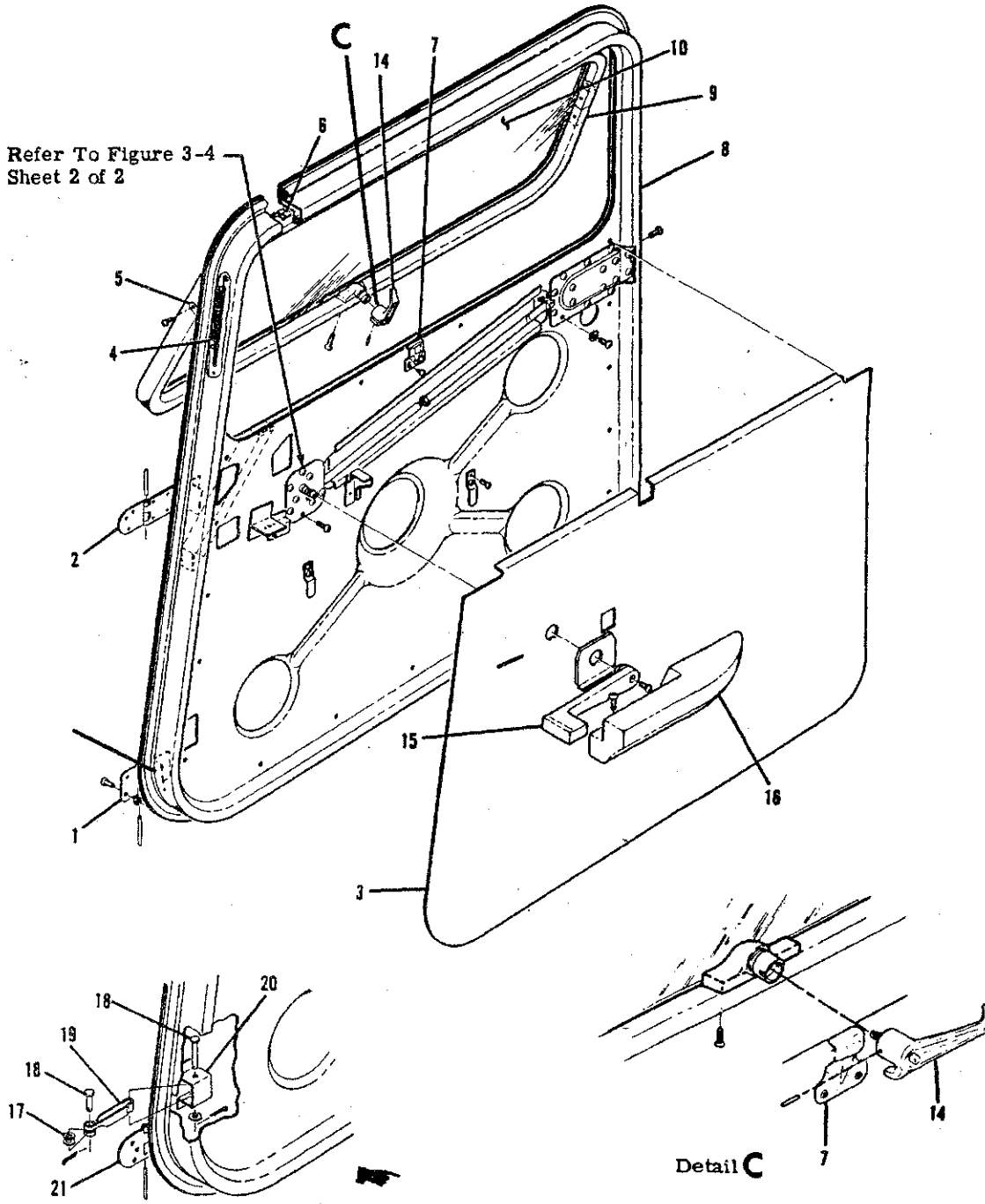

**Detail D**  
BEGINNING WITH SERIALS  
17265685 AND F17201385

- 17. Washer
- 18. Clevis Pin
- 19. Door Stop Spring
- 20. Door Stop Bracket
- 21. Lower Hinge

**Detail C**

Figure 3-3. Cabin Door Installation (Sheet 2 of 2)



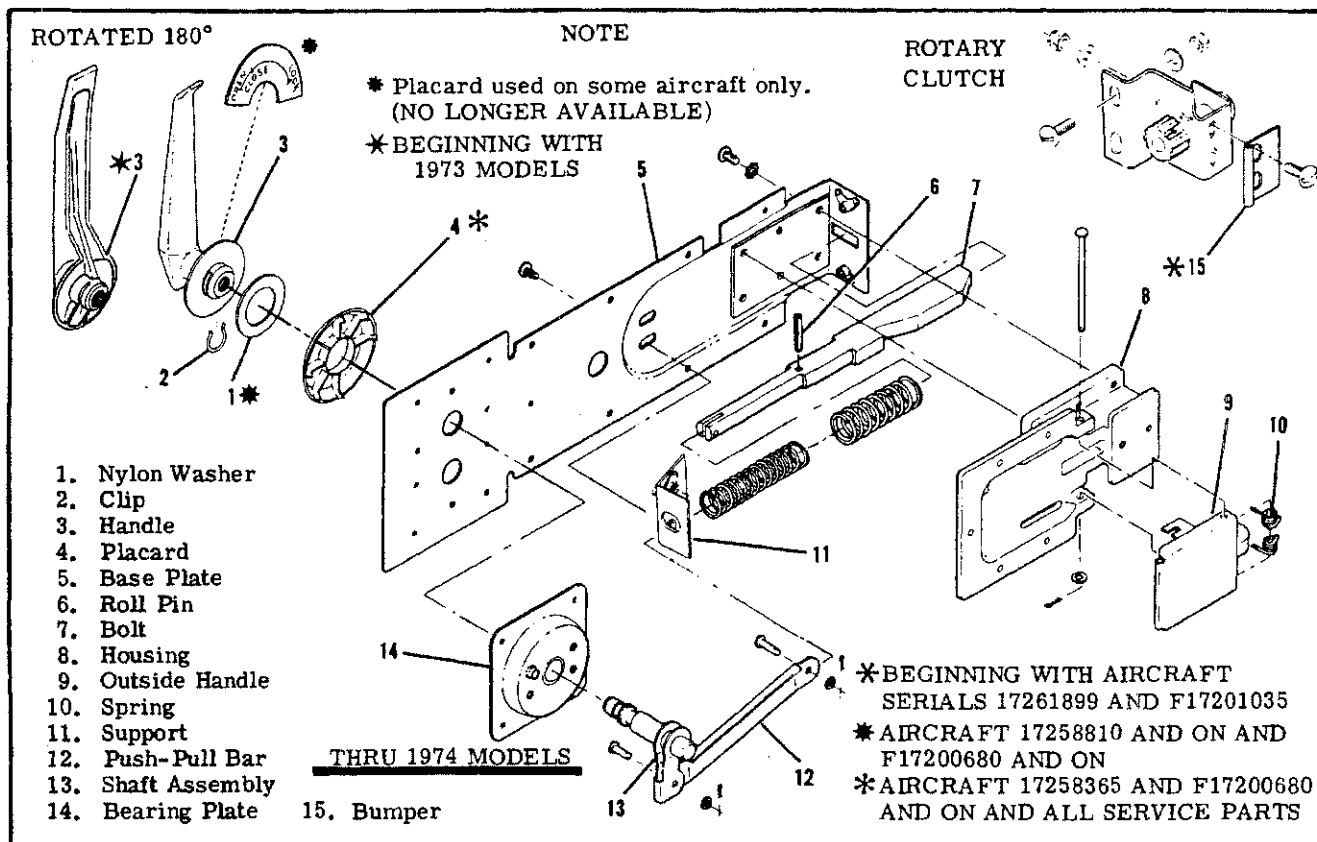

Figure 3-4. Door Latch Installation (Sheet 1 of 2)

3-28. INDEXING INSIDE HANDLE. (Refer to figure 3-4.) When inside door handle is removed, reinstall in relation to position of bolt (7) which is spring-loaded to CLOSE position. The following procedure may be used.

a. THRU AIRCRAFT 17259903 AND F1720804, AND 17260759 THRU 17263458 AND F17200905 THRU F17201143.

1. Temporarily install handle (3) on shaft assembly (13) approximately vertical.

2. Move handle (3) back and forth until handle centers in spring-loaded position.

3. Without rotating shaft assembly (13), remove handle and install placard (4) with CLOSE index at top and press placard to seat prongs.

4. Install nylon washer (1).

5. Install handle (3) to align with CLOSE index on placard (4) and install clip (2).

6. Ensure bolt (7) clears doorpost and teeth engage clutch gear when handle (3) is in CLOSE position.

b. AIRCRAFT 17259904 THRU 17260758 AND F17200805 THRU F17200904.

1. Temporarily install handle (3) on shaft assembly (13) approximately horizontal, pointing aft.

2. Move handle (3) back and forth until handle centers in spring-loaded position.

3. Without rotating shaft assembly (13), remove handle and install placard (4) with CLOSE index aft and press placard to seat prongs.

4. Install nylon washers (1).

5. Install handle (3) to align with CLOSE index on placard (4) and install clip (2).

6. Ensure bolt (7) clears doorpost and teeth engage clutch gear when handle (3) is in CLOSE position.

c. BEGINNING WITH 17263459 AND F17201144. (Refer to figure 3-4, sheet 2.)

1. Temporarily install handle (24) on shaft assembly (18) approximately vertical.

2. Move handle (24) back and forth until handle centers in spring-loaded position.

3. Without rotating shaft assembly (18), remove handle (24) and install placard (25) with CLOSE index at top.

4. Install handle (24) to align with CLOSE index on placard (25), using screw (26).

5. Install arm rest (23) on upholstery panel (22).

3-29. BAGGAGE DOOR. (Refer to figure 3-5.)

3-30. REMOVAL AND INSTALLATION.

a. Remove inside latch handle (1). (SERIALS 17258487 THRU 17259587 AND F17200655 THRU F17200804 ONLY)

b. Remove door-pull handle (14).

c. Disconnect door-stop chain (7).

d. Remove buttons securing upholstery panel and remove panel.

e. Remove bolts (11) securing door to hinges.

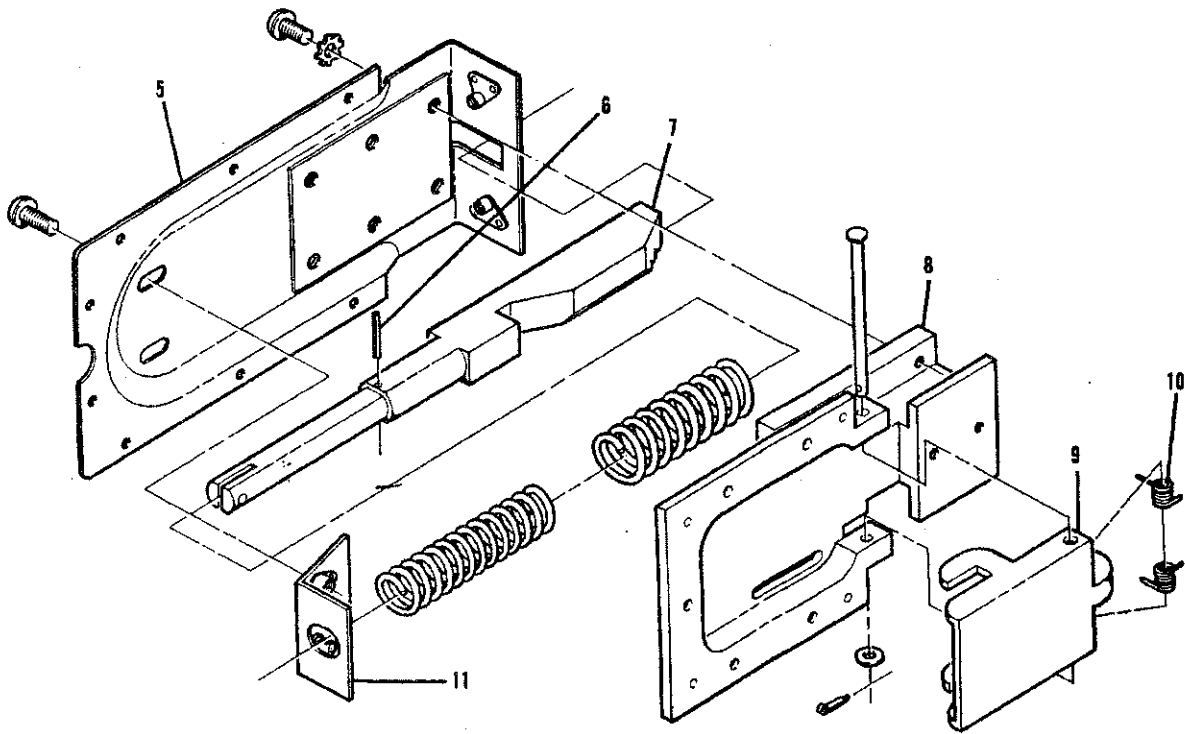

Detail **A**  
Rotated 180°

\* BEGINNING WITH SERIAL 17265288  
AND F17201385

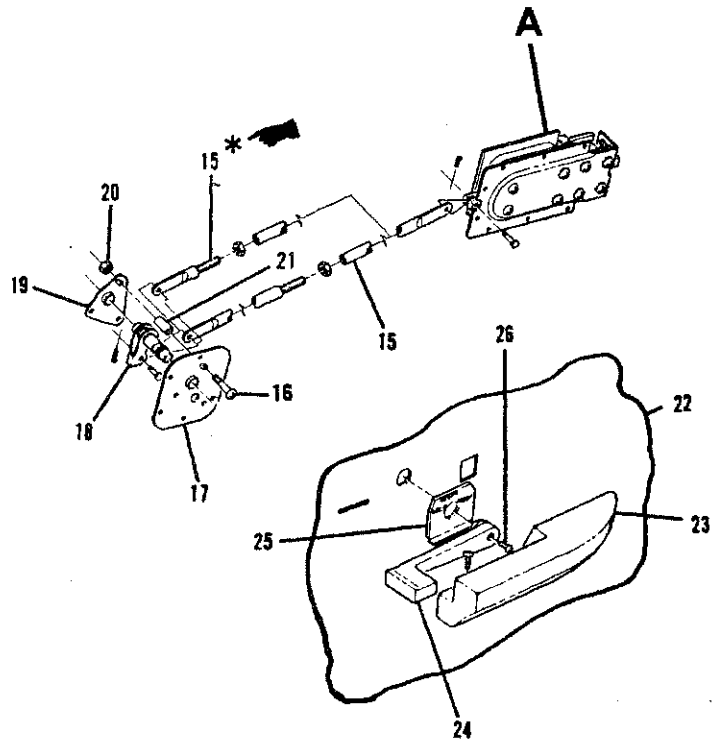

- 15. Push Pull Rod
- 16. Screw
- 17. Plate Assembly
- 18. Shaft Assembly
- 19. Bearing Assembly
- 20. Nut
- 21. Spacer
- 22. Upholstery Panel
- 23. Arm Rest
- 24. Inside Door Handle
- 25. Plate
- 26. Screw

BEGINNING WITH 1975 MODELS

Figure 3-4. Door Latch Installation (Sheet 2 of 2)

**NOTE**

Beginning with 1974 Models the baggage compartment is extended approximately 3 feet aft.

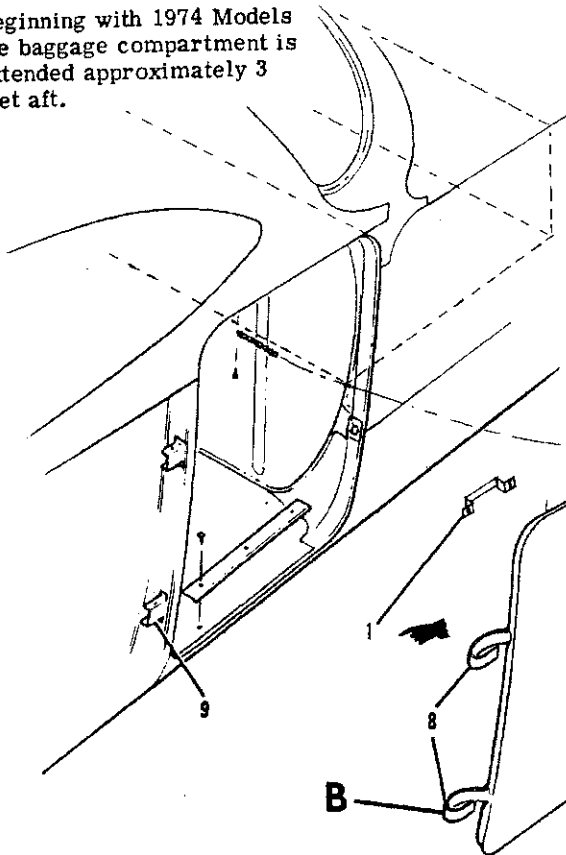

THRU SERIALS 17258486 AND F17200654

Detail **A**

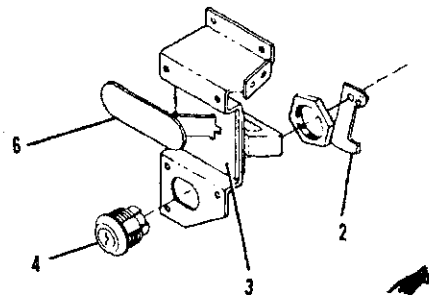

BEGINNING WITH 17258487 AND F17200655

Detail **A**

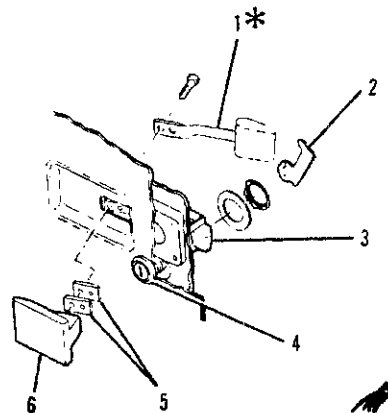

\* THRU AIRCRAFT SERIALS  
17259587 AND F17200804

**NOTE**

A bonded baggage door is installed on AIRCRAFT SERIAL 17259287 AND ON. Refer to Section 18 for repair.

**NOTE**

Forming of the bonded baggage door flange in order to fair with the fuselage is not permissible since damage may result to the bonded areas.

- |                   |                  |
|-------------------|------------------|
| 1. Inside Handle  | 8. Hinge         |
| 2. Cam            | 9. Hinge Bracket |
| 3. Latch Assembly | 10. Clevis Pin   |
| 4. Lock Assembly  | 11. Bolt         |
| 5. Shim           | 12. Cotter Pin   |
| 6. Outside Handle | 13. Nut          |
| 7. Chain          |                  |

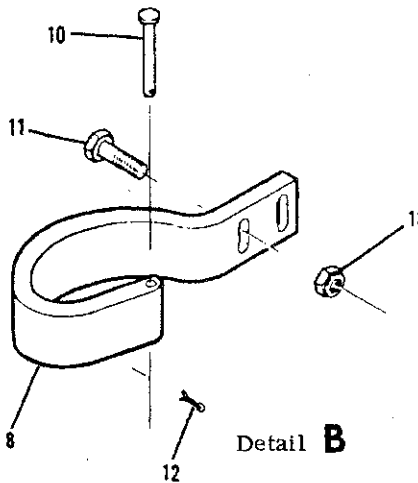

Detail **B**

Figure 3-5. Baggage Door Installation

- f. Reverse preceding steps for installation.

**NOTE**

When fitting a new door, trimming of door at edges and reforming with a soft mallet may be necessary to achieve a good fit. Reforming of the bonded door could cause damage to the bonded area and is not permissible.

- 3-31. SEATS. (Refer to figure 3-6.)

- 3-32. PILOT AND COPILOT.  
a. RECLINING BACK.  
b. VERTICAL ADJUST/RECLINING BACK.  
c. ARTICULATING RECLINE/VERTICAL ADJUST.

3-33. DESCRIPTION. These seats are manually-operated throughout their full range of operation. Seat stops are provided to limit fore-and-aft travel.

- 3-34. REMOVAL AND INSTALLATION.  
a. Remove seat stops from rails.  
b. Slide seat fore-and-aft to disengage seat rollers from rails.  
c. Lift seat out.  
d. Reverse preceding steps for installation. Ensure all seat stops are reinstalled.

**WARNING**

It is extremely important that pilot's seat stops are installed, since acceleration and deceleration could possibly permit seat to become disengaged from seat rails and create a hazardous situation, especially during take-off and landing.

- 3-35. CENTER.  
a. DOUBLE-WIDTH BOTTOM AND BACK/SINGLE RECLINING BACK.  
b. DOUBLE-WIDTH BOTTOM/INDIVIDUAL RECLINING BACKS.

3-36. DESCRIPTION. These seats are permanently bolted to the cabin structure and incorporate no adjustment provisions other than manually-adjustable three position backs.

- 3-37. REMOVAL AND INSTALLATION.  
a. Remove bolts securing seat to cabin structure.  
b. Lift seat out.  
c. Reverse preceding steps for installation.

- 3-38. AUXILIARY.  
a. FOLD-UP.

3-39. DESCRIPTION. These seats are permanently bolted to the cabin structure and have no adjustment provisions. The seat structure is mounted on hinge brackets with pivot bolts, thus allowing seat to be pivoted upward to acquire more baggage area.

- 3-40. REMOVAL AND INSTALLATION.  
a. Remove bolts securing seat structure to hinge brackets.

3-8

- b. Unsnap seat back from aft cabin wall. (1969 Model).  
c. Lift seat out.  
d. Reverse preceding steps for installation.

3-41. REPAIR. Replacement of defective parts is recommended in repair of seats. However, a cracked framework may be welded, provided the crack is not in an area of stress concentration (close to a hinge or bearing point). The square-tube framework is 6061 aluminum, heat-treated to a T-6 condition. Use a heliarc weld on these seats, as torch welds will destroy heat-treatment of frame structure. Figure 3-7 outlines instructions for replacing defective cams on reclining bench-type seat backs.

3-42. CABIN UPHOLSTERY. Due to the wide selection of fabrics, styles and colors, it is impossible to depict each particular type of upholstery. The following paragraphs describe general procedures which will serve as a guide in removal and replacement of upholstery. Major work, if possible, should be done by an experienced mechanic. If the work must be done by a mechanic unfamiliar with upholstery practices, the mechanic should make careful notes during removal of each item to facilitate replacement later.

3-43. MATERIALS AND TOOLS. Materials and tools will vary with the job. Scissors for trimming upholstery to size and a dull-bladed putty knife for wedging material beneath retainer strips are the only tools required for most trim work. Use industrial rubber cement to hold soundproofing mats and fabric edges in place. Refer to Section 18 for thermo-plastic repairs.

3-44. SOUNDPROOFING. The aircraft is insulated with spun glass mat-type insulation and a sound deadener compound applied to inner surfaces of skin in most areas of cabin and baggage compartment. All soundproofing material should be replaced in its original position any time it is removed. A soundproofing panel is placed in gap between wing and fuselage and held in place by wing root fairings.

- 3-45. CABIN HEADLINER. (Refer to figure 3-8.)

- 3-46. REMOVAL AND INSTALLATION.  
a. Detail A.  
1. Remove sun visors, all inside finish strips and plates, doorpost upper shields, front spar trim shield, dome light console and any other visible retainers securing headliner.  
2. Work edges of headliner free from metal teeth which hold fabric.  
3. Starting at front of headliner, work headliner down, removing screws through metal tabs which hold wire bows to cabin top. Pry loose outer ends of bows from retainers above doors. Detach each wire bow in succession.

**NOTE**

Always work from front to rear when removing headliner.

**PILOT AND COPILOT SEATS**

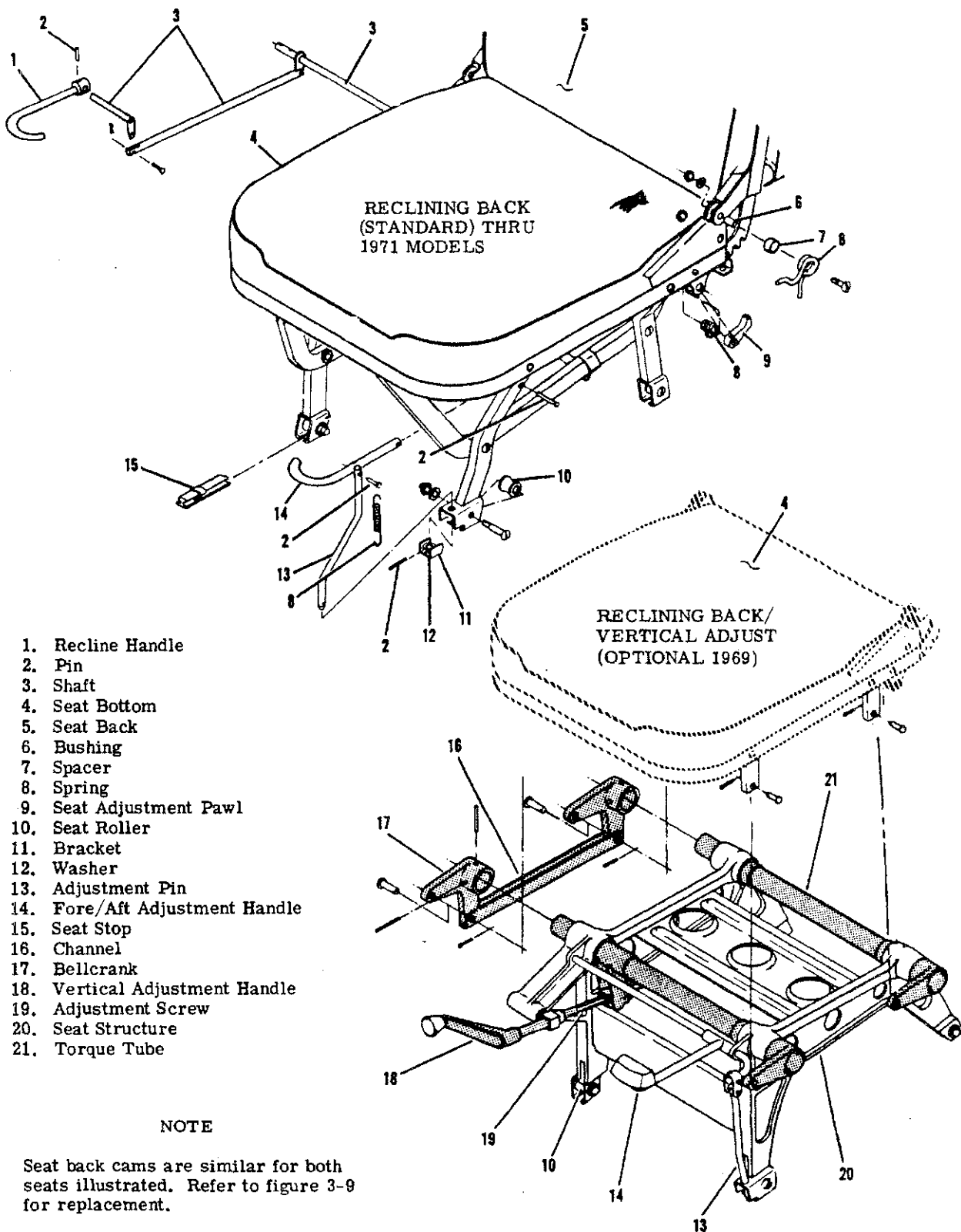

1. Recline Handle
2. Pin
3. Shaft
4. Seat Bottom
5. Seat Back
6. Bushing
7. Spacer
8. Spring
9. Seat Adjustment Pawl
10. Seat Roller
11. Bracket
12. Washer
13. Adjustment Pin
14. Fore/Aft Adjustment Handle
15. Seat Stop
16. Channel
17. Bellcrank
18. Vertical Adjustment Handle
19. Adjustment Screw
20. Seat Structure
21. Torque Tube

**NOTE**

Seat back cams are similar for both seats illustrated. Refer to figure 3-9 for replacement.

Figure 3-6. Seat Installation (Sheet 1 of 8)

PILOT AND COPILOT  
(STANDARD)  
BEGINNING WITH 1973  
MODELS

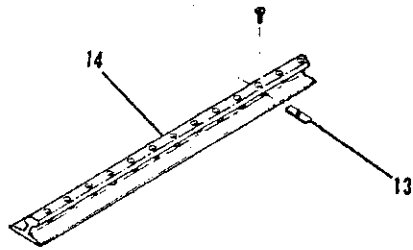

Install seat stop in eleventh hole from the front of the outboard seat rail.

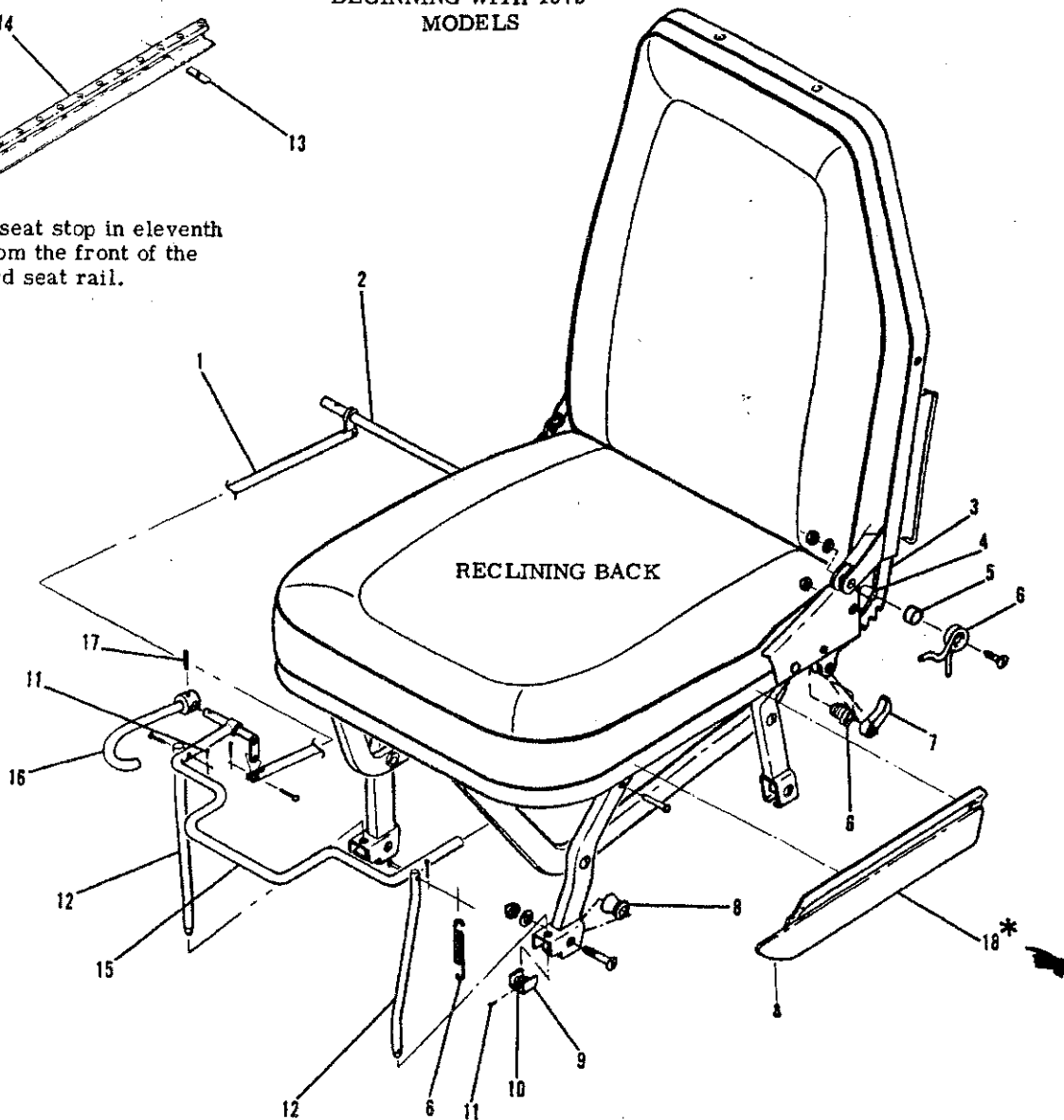

NOTE

Refer to figure 3-7 for seat back cam replacement.

\* BEGINNING WITH SERIALS  
17265485 AND F17201385

- |                             |                                |
|-----------------------------|--------------------------------|
| 1. Link Seat Back Adjust    | 10. Washer                     |
| 2. Torque Tube              | 11. Pin                        |
| 3. Seat Back Adjustment Cam | 12. Adjustment Pin             |
| 4. Bushing                  | 13. Seat Stop                  |
| 5. Spacer                   | 14. Seat Rail                  |
| 6. Spring                   | 15. Fore/Aft Adjustment Handle |
| 7. Seat Adjustment Pawl     | 16. Recline Handle             |
| 8. Roller                   | 17. Roll Pin                   |
| 9. Bracket                  | 18. Seat Belt Retainer         |

Figure 3-6. Seat Installation (Sheet 2 of 8)

PILOT AND COPILOT SEATS

NOTE

\*Nut is rotated 180° BEGINNING WITH AIRCRAFT 17259904.

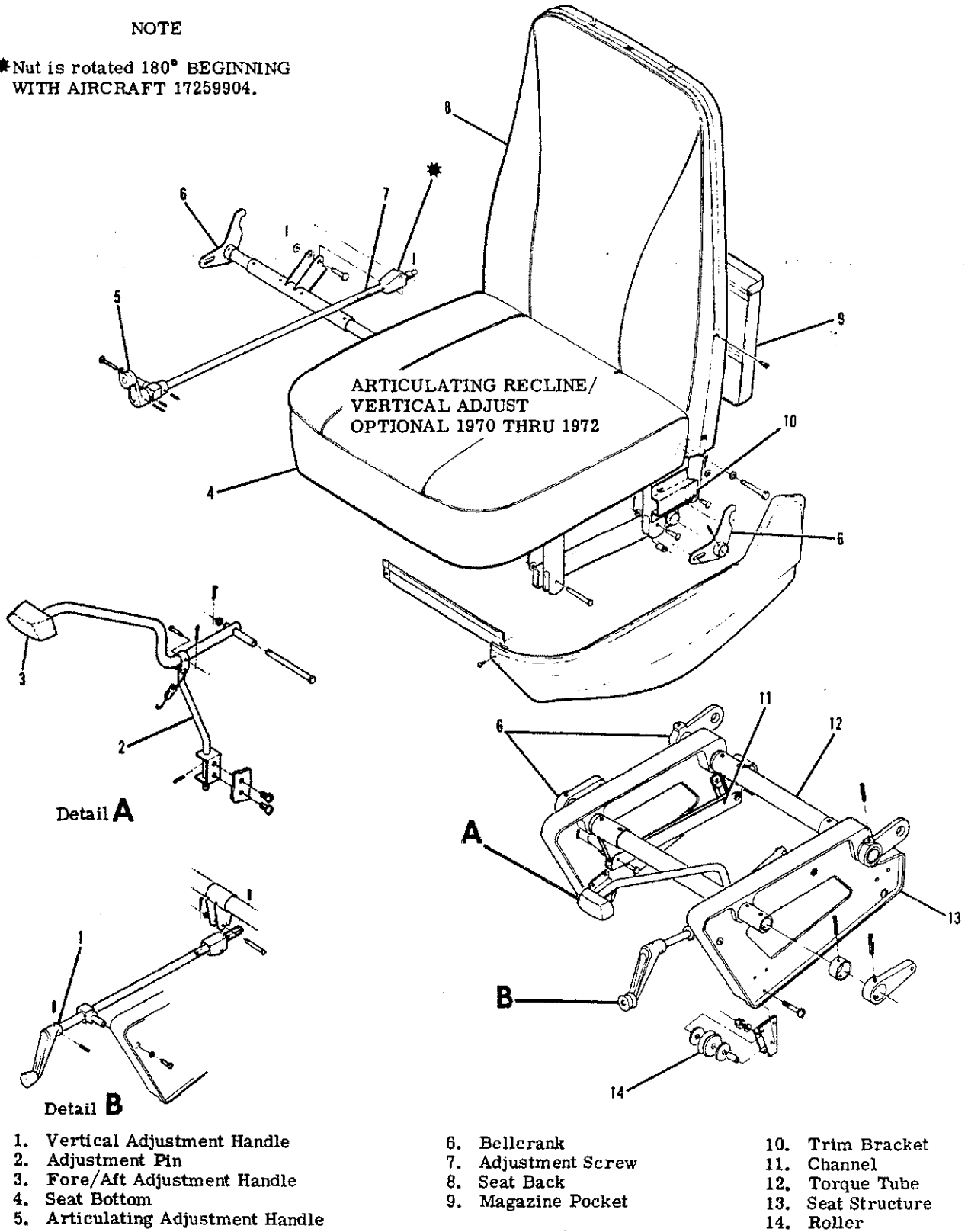

- 1. Vertical Adjustment Handle
- 2. Adjustment Pin
- 3. Fore/Aft Adjustment Handle
- 4. Seat Bottom
- 5. Articulating Adjustment Handle

- 6. Bellcrank
- 7. Adjustment Screw
- 8. Seat Back
- 9. Magazine Pocket

- 10. Trim Bracket
- 11. Channel
- 12. Torque Tube
- 13. Seat Structure
- 14. Roller

Figure 3-6. Seat Installation (Sheet 3 of 8)

**PILOT AND COPILOT SEATS**

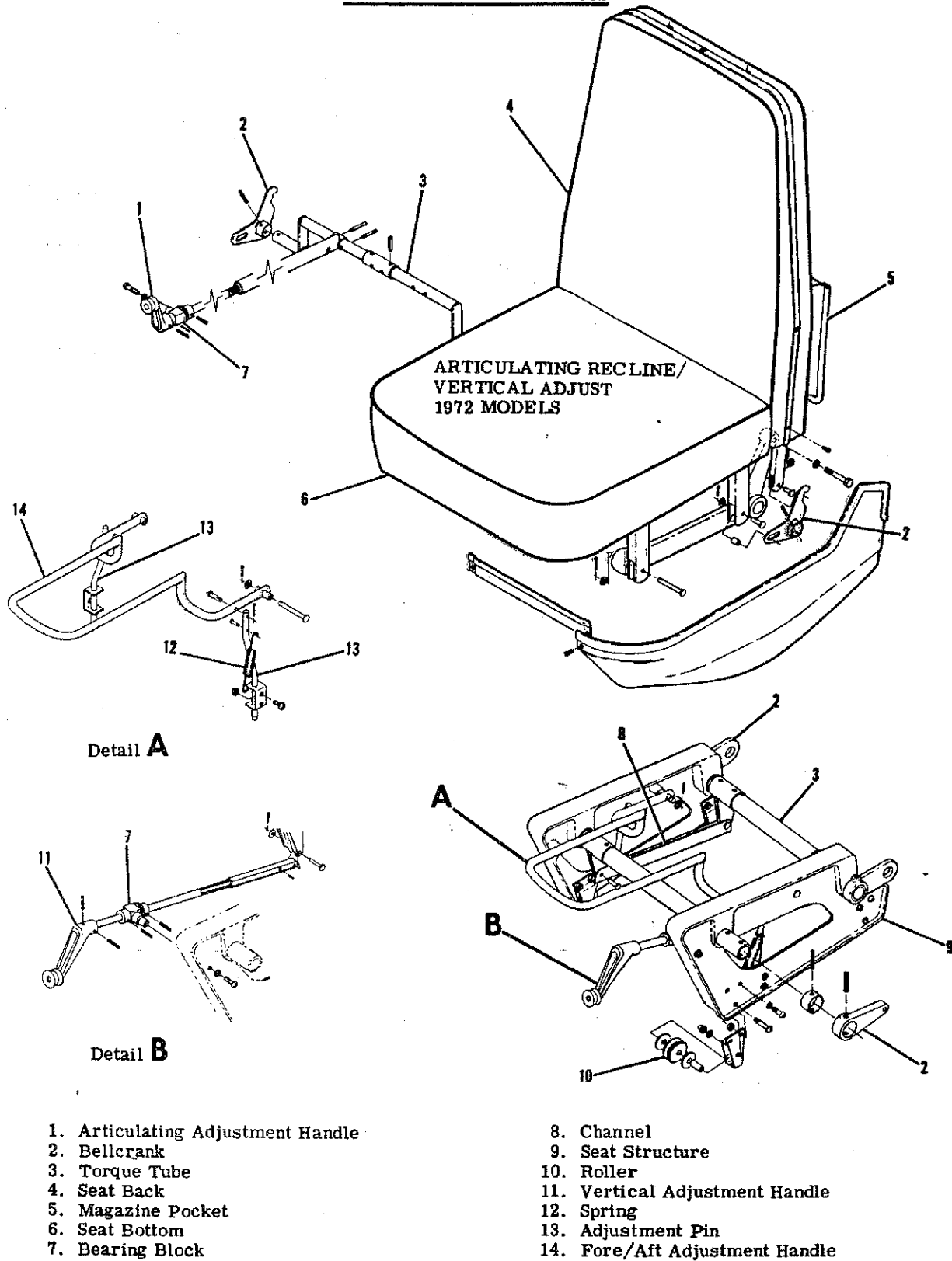

Figure 3-6. Seat Installation (Sheet 4 of 8)



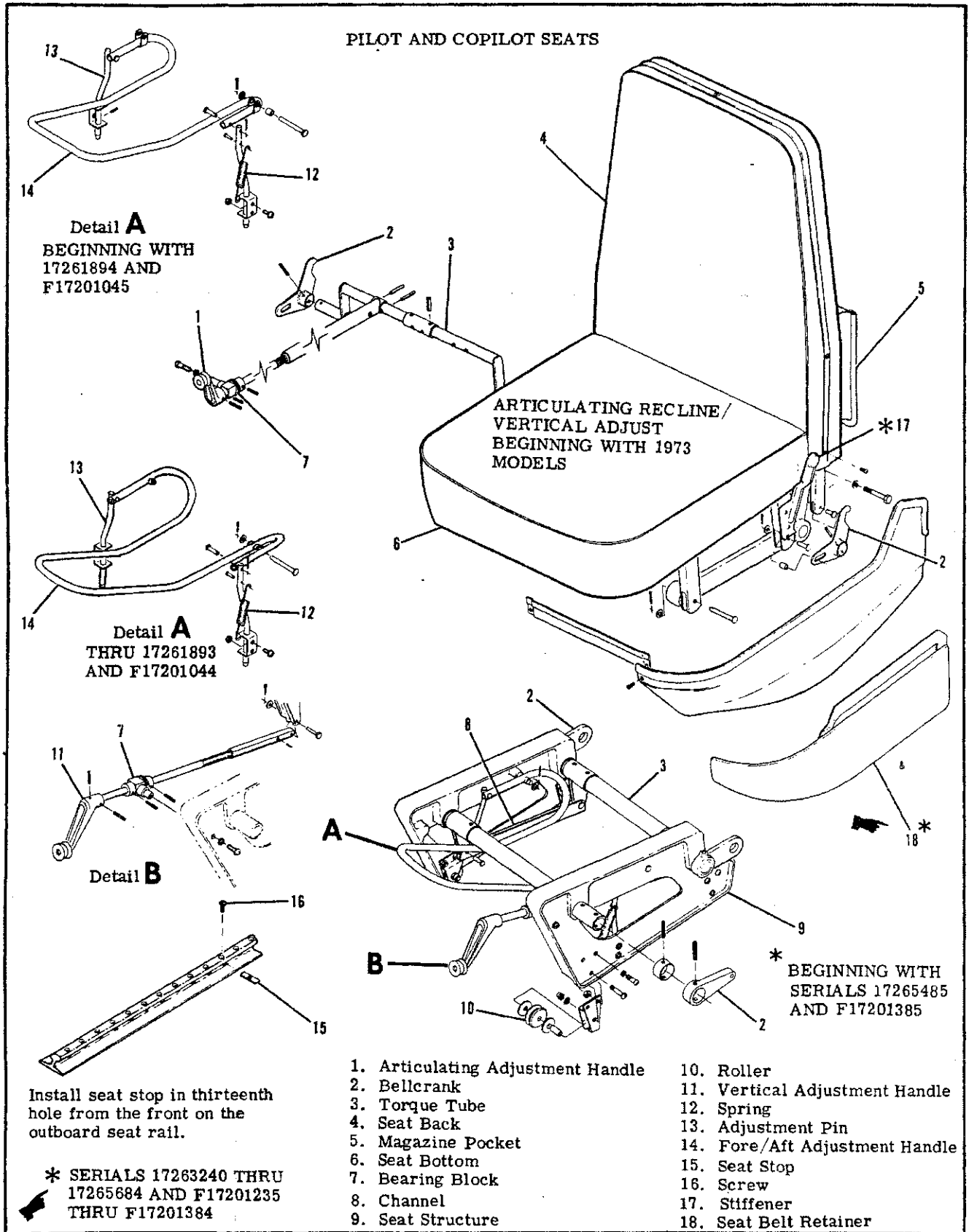
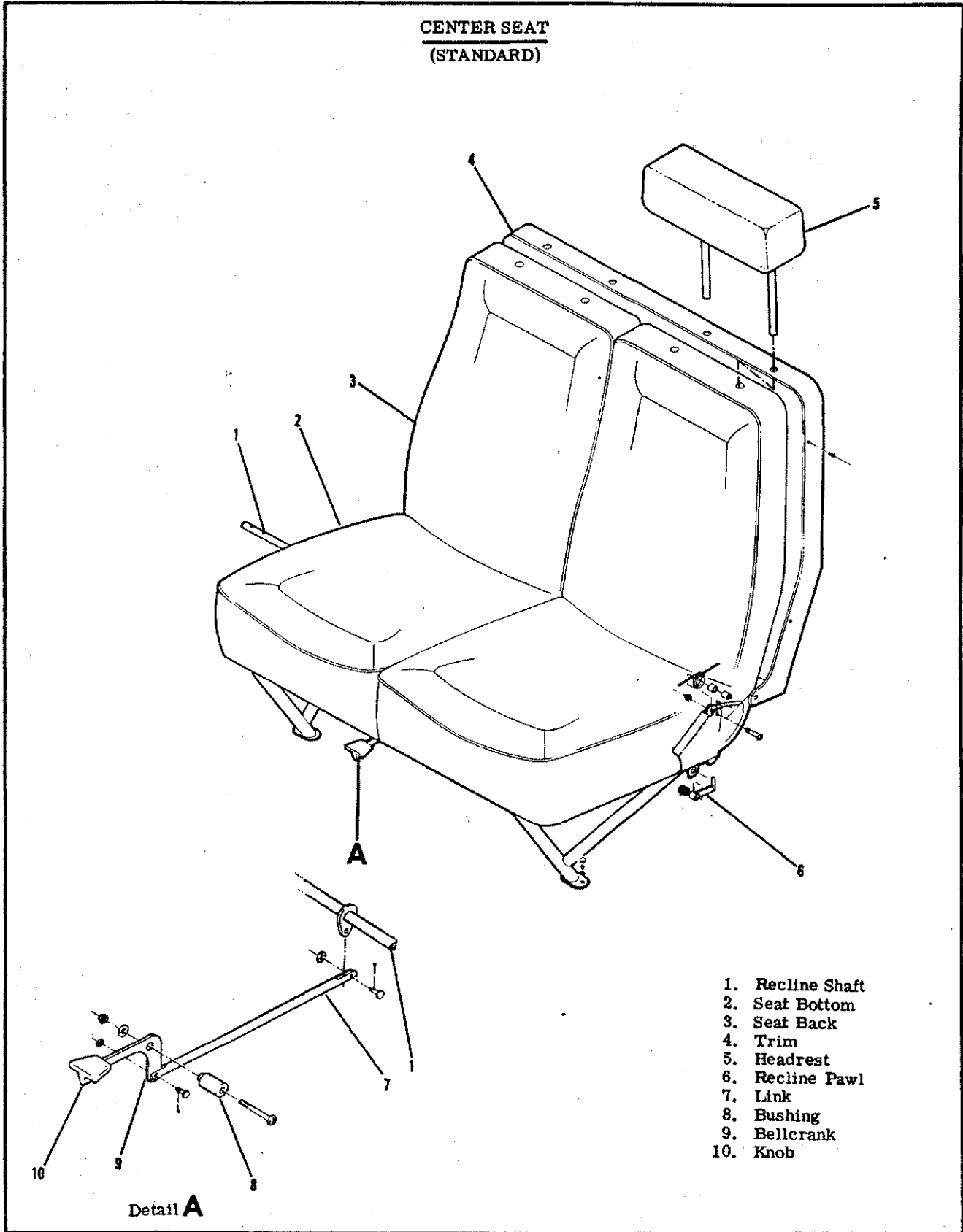

Figure 3-6. Seat Installation (Sheet 5 of 8)

**CENTER SEAT  
(STANDARD)**



- 1. Recline Shaft
- 2. Seat Bottom
- 3. Seat Back
- 4. Trim
- 5. Headrest
- 6. Recline Pawl
- 7. Link
- 8. Bushing
- 9. Bellcrank
- 10. Knob

Detail A

Figure 3-6. Seat Installation (Sheet 6 of 8)

**CENTER SEAT  
(OPTIONAL)**

- 1. Seat Bottom
- 2. Spring
- 3. Spacer
- 4. Seat Back
- 5. Bushing
- 6. Recline Handle
- 7. Pawl
- 8. Control Shaft

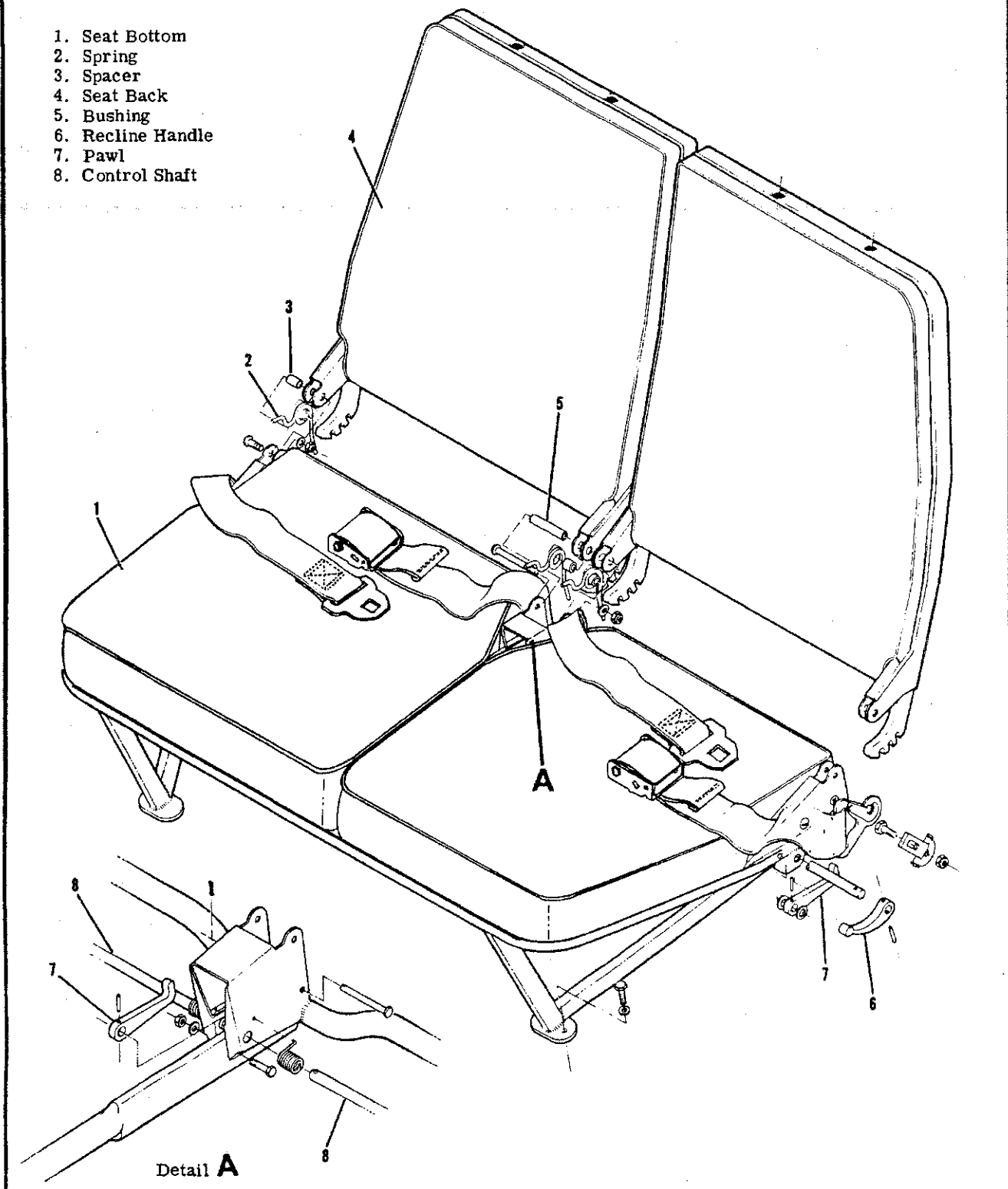

Figure 3-6. Seat Installation (Sheet 7 of 8)

**AUXILIARY SEATS**

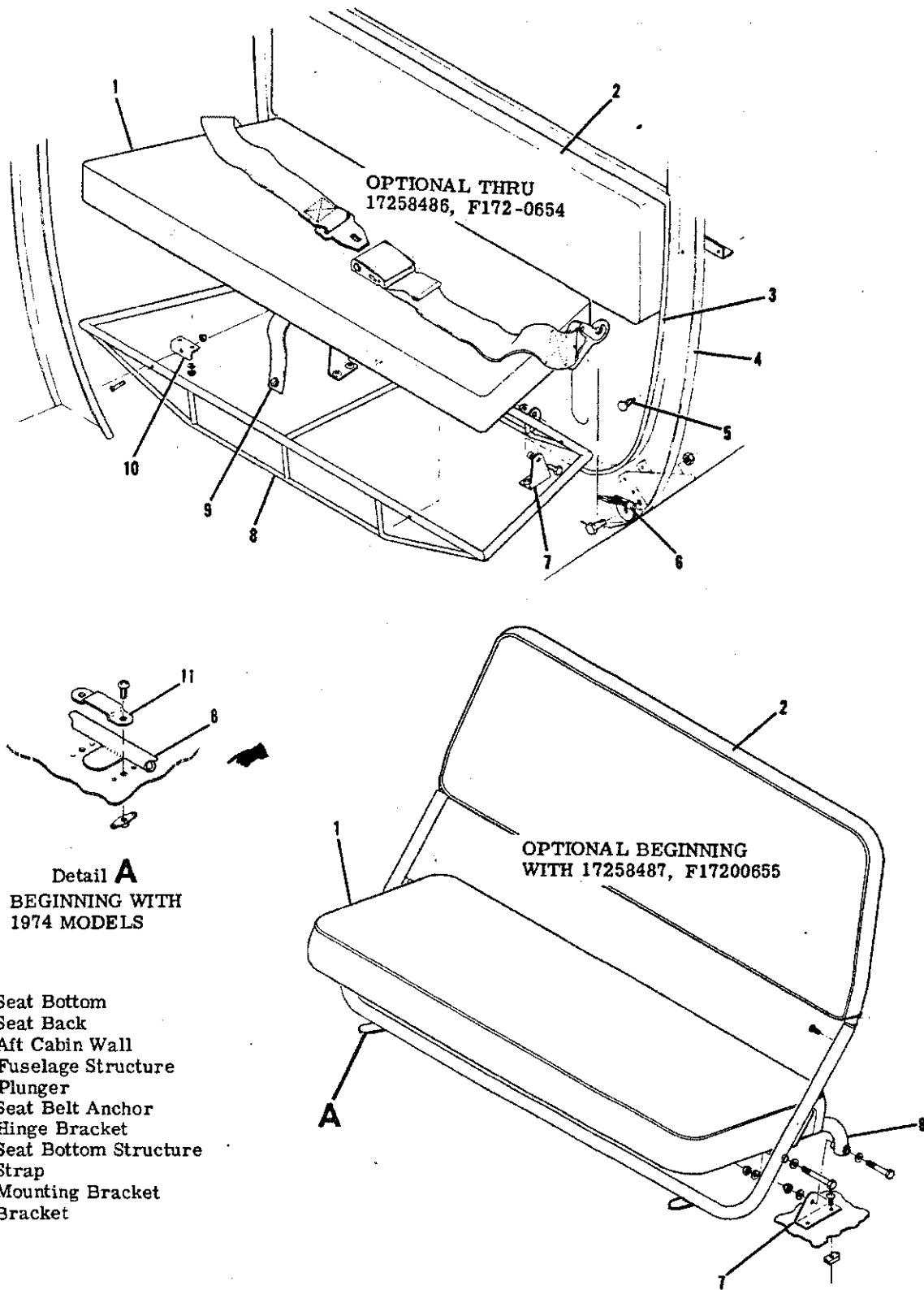
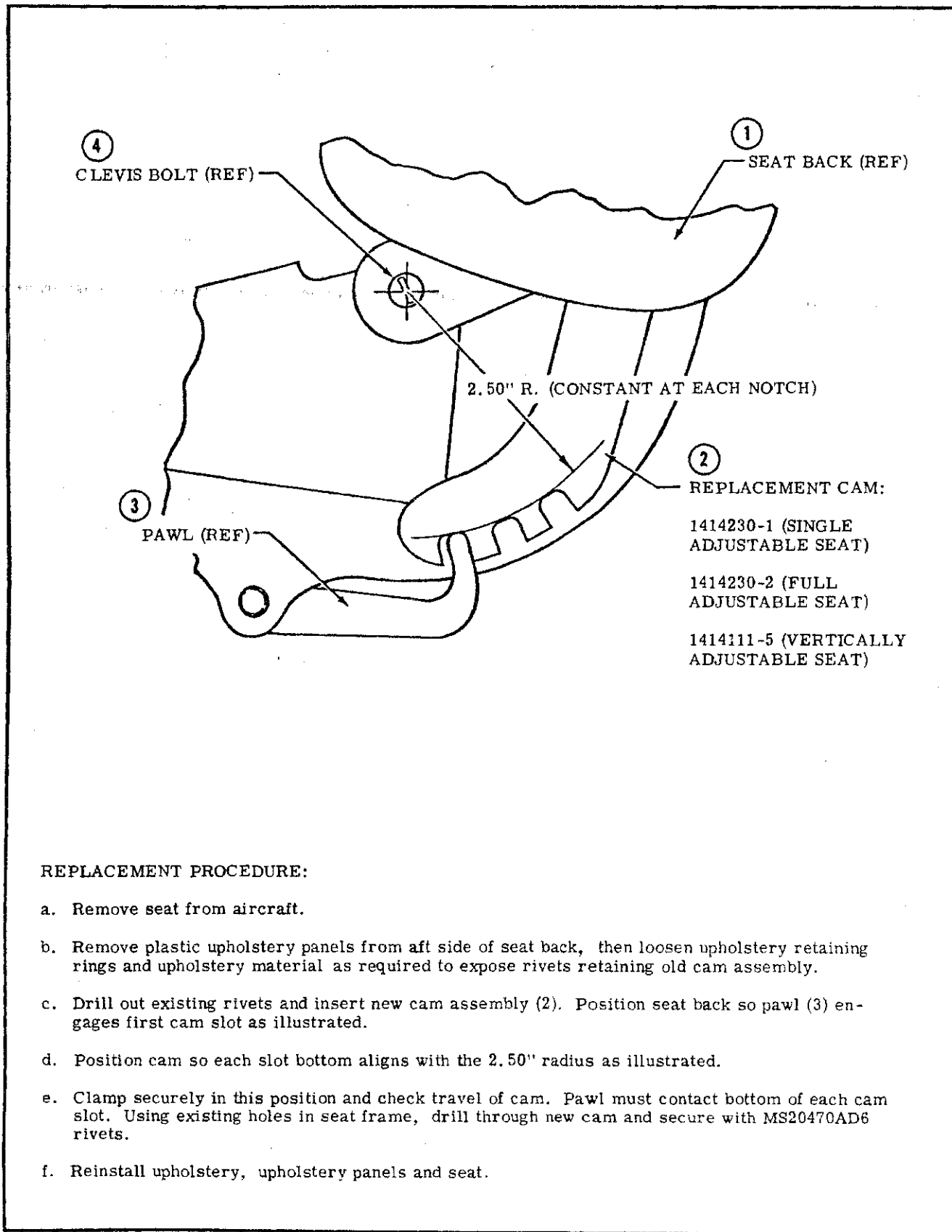

Figure 3-6. Seat Installation (Sheet 8 of 8)



**REPLACEMENT PROCEDURE:**

- a. Remove seat from aircraft.
- b. Remove plastic upholstery panels from aft side of seat back, then loosen upholstery retaining rings and upholstery material as required to expose rivets retaining old cam assembly.
- c. Drill out existing rivets and insert new cam assembly (2). Position seat back so pawl (3) engages first cam slot as illustrated.
- d. Position cam so each slot bottom aligns with the 2.50" radius as illustrated.
- e. Clamp securely in this position and check travel of cam. Pawl must contact bottom of each cam slot. Using existing holes in seat frame, drill through new cam and secure with MS20470AD6 rivets.
- f. Reinstall upholstery, upholstery panels and seat.

Figure 3-7. Seat Back Cam Replacement

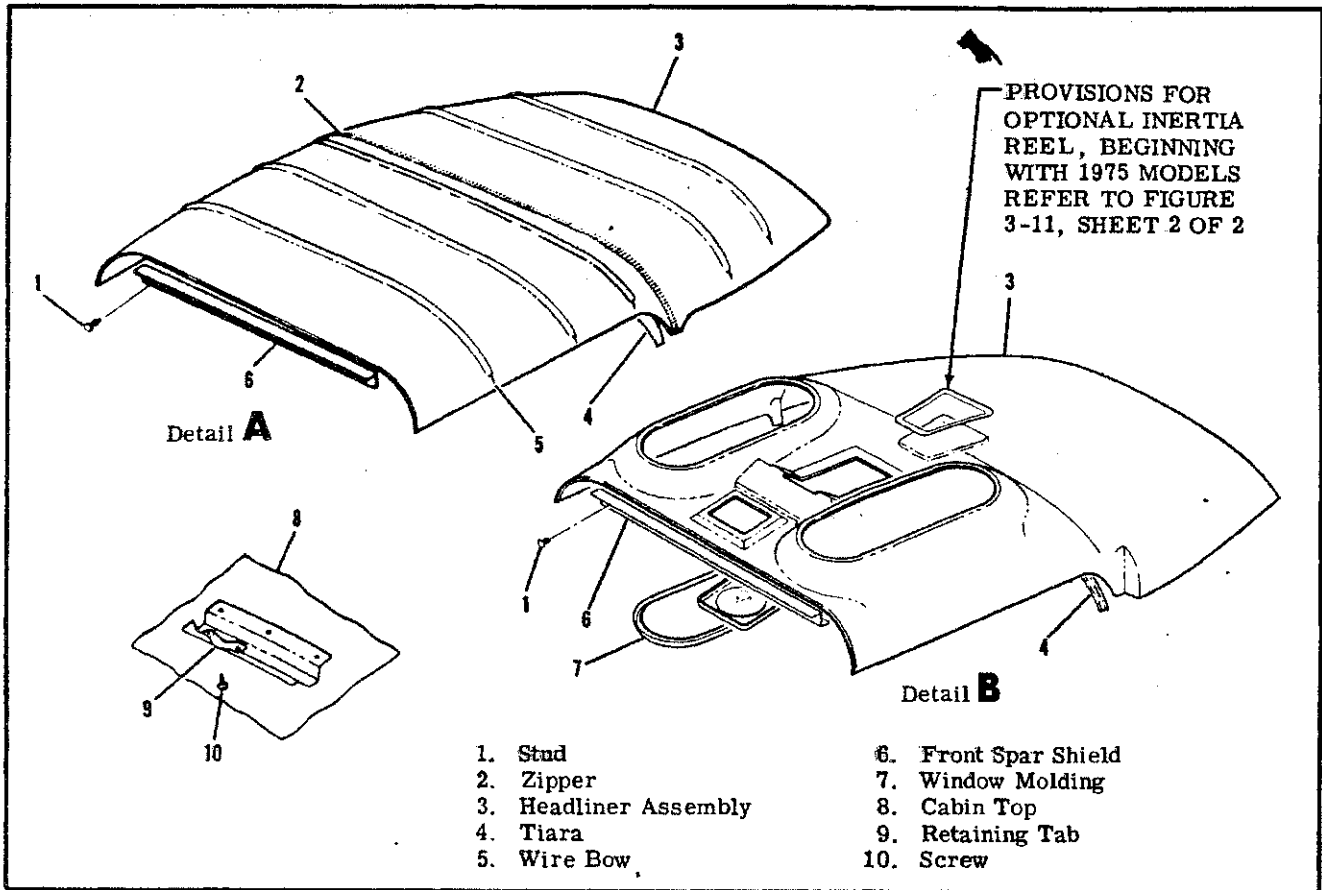

Figure 3-8. Cabin Headliner Installation

4. Remove headliner assembly and bows from aircraft.

**NOTE**

Due to difference in length and contour of wire bows, each bow should be tagged to assure proper location in headliner.

5. Remove spun glass soundproofing panels.

**NOTE**

The lightweight soundproofing panels are held in place with industrial rubber cement.

6. Reverse preceding steps for installation. Before installation, check all items concealed by headliner for security. Use wide cloth tape to secure loose wires to fuselage and to seal openings in wing roots. Straighten tabs bent during removal of headliner.

7. Apply cement to inside of skin in areas where soundproofing panels are not supported by wire bows and press soundproofing in place.

8. Insert wire bows into headliner seams and secure two bows at rear of headliner. Stretch material

along edges to properly center, but do not stretch it tight enough to destroy ceiling contours or distort wire bows. Secure edges of headliner with metal teeth.

9. Work headliner forward, installing each wire bow in place with metal tabs. Wedge ends of wire bows into the retainer strips. Stretch headliner just taut enough to avoid wrinkles and maintain a smooth contour.

10. When all bows are in place and fabric edges are secured, trim off excess fabric and reinstall all items removed.

b. Detail B.

1. Remove sun visors, all inside finish strips and plates, overhead console, upper doorpost shields and any other visible retainers securing headliner.

2. Remove molding from fixed windows.

3. Remove screws securing headliner and carefully take down headliner.

4. Remove spun glass soundproofing panels above headliner.

**NOTE**

The lightweight soundproofing panels are held in place with industrial rubber cement.

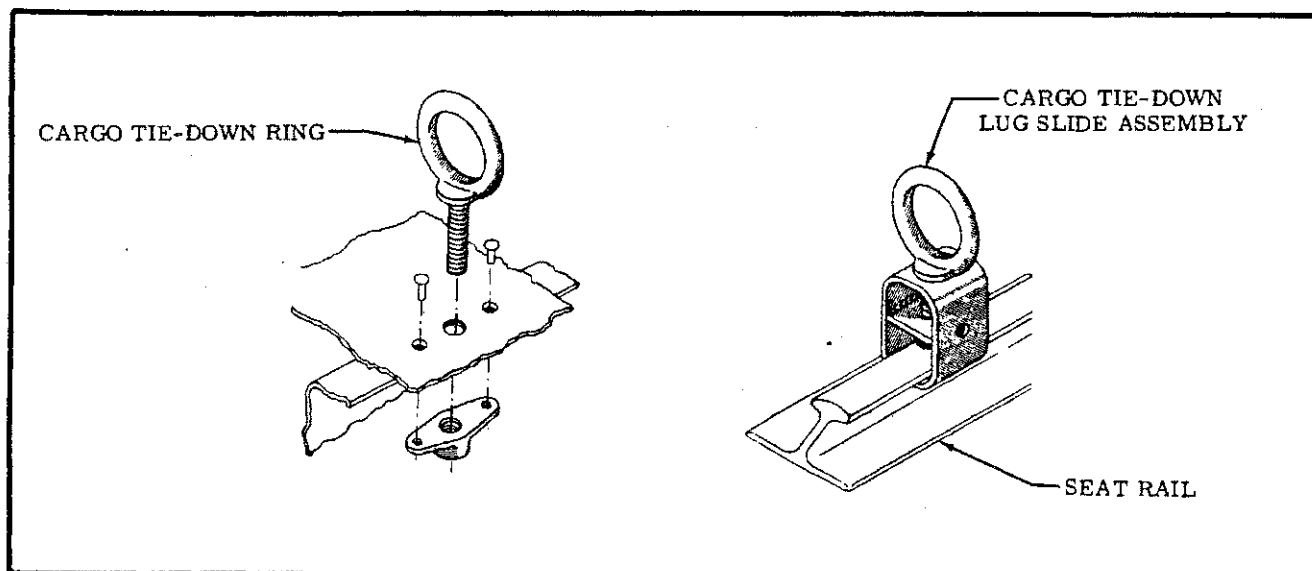

Figure 3-9. Cargo Tie-Down Rings

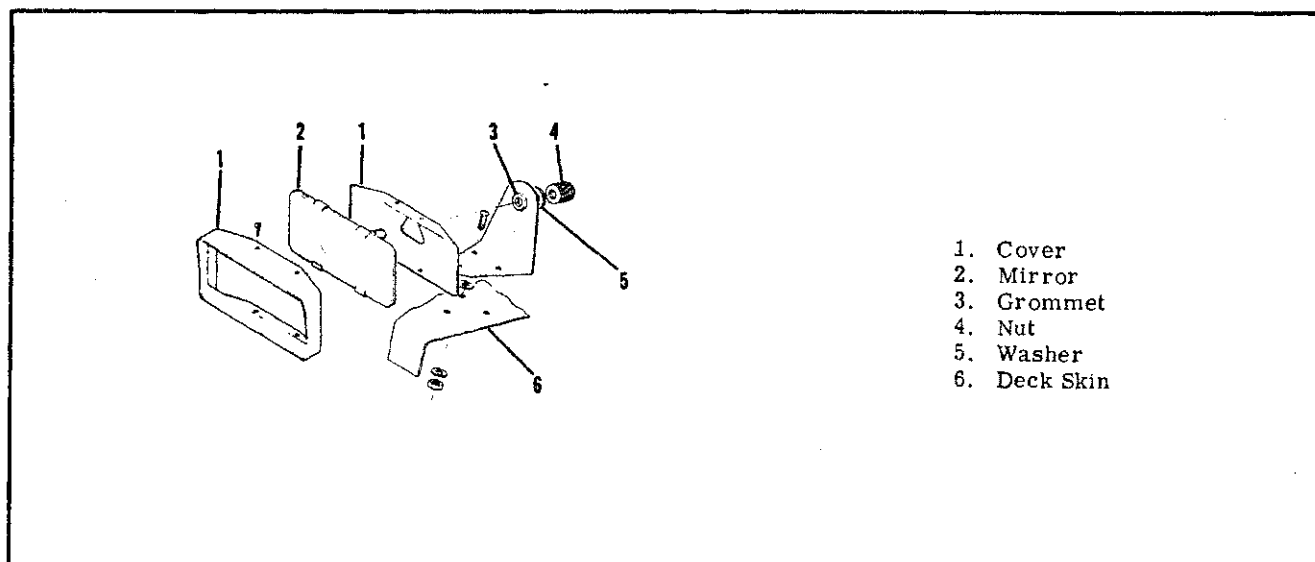

Figure 3-10. Rear View Mirror Installation

5. Reverse preceding steps for installation. Before installation, check all items concealed by headliner for security. Use wide cloth tape to secure loose wires to fuselage and to seal openings in wing roots.

3-47. UPHOLSTERY SIDE PANELS. Removal of upholstery side panels is accomplished by removing seats for access, then removing parts attaching panels. Remove screws, retaining strips, arm rests and ash trays as required to free panels. Automotive type spring clips attach most door panels. A dull putty knife makes an excellent tool for prying clips loose. When installing side panels, do not over-tighten screws. Larger screws may be used in enlarged holes as long as area behind hole is

checked for electrical wiring, fuel lines and other components which might be damaged by using a longer screw.

3-48. CARPETING. Cabin area and baggage compartment carpeting is held in place by rubber cement, small sheet metal screws and retaining strips. When fitting a new carpet, use old one as a pattern for trimming and marking screw holes.

3-49. SAFETY PROVISIONS.

3-50. CARGO TIE-DOWNS. Cargo tie-downs are used to ensure baggage cannot enter seating area during flight. Methods of attaching tie-downs are illustrated in figure 3-9. The eyebolt and nutplate





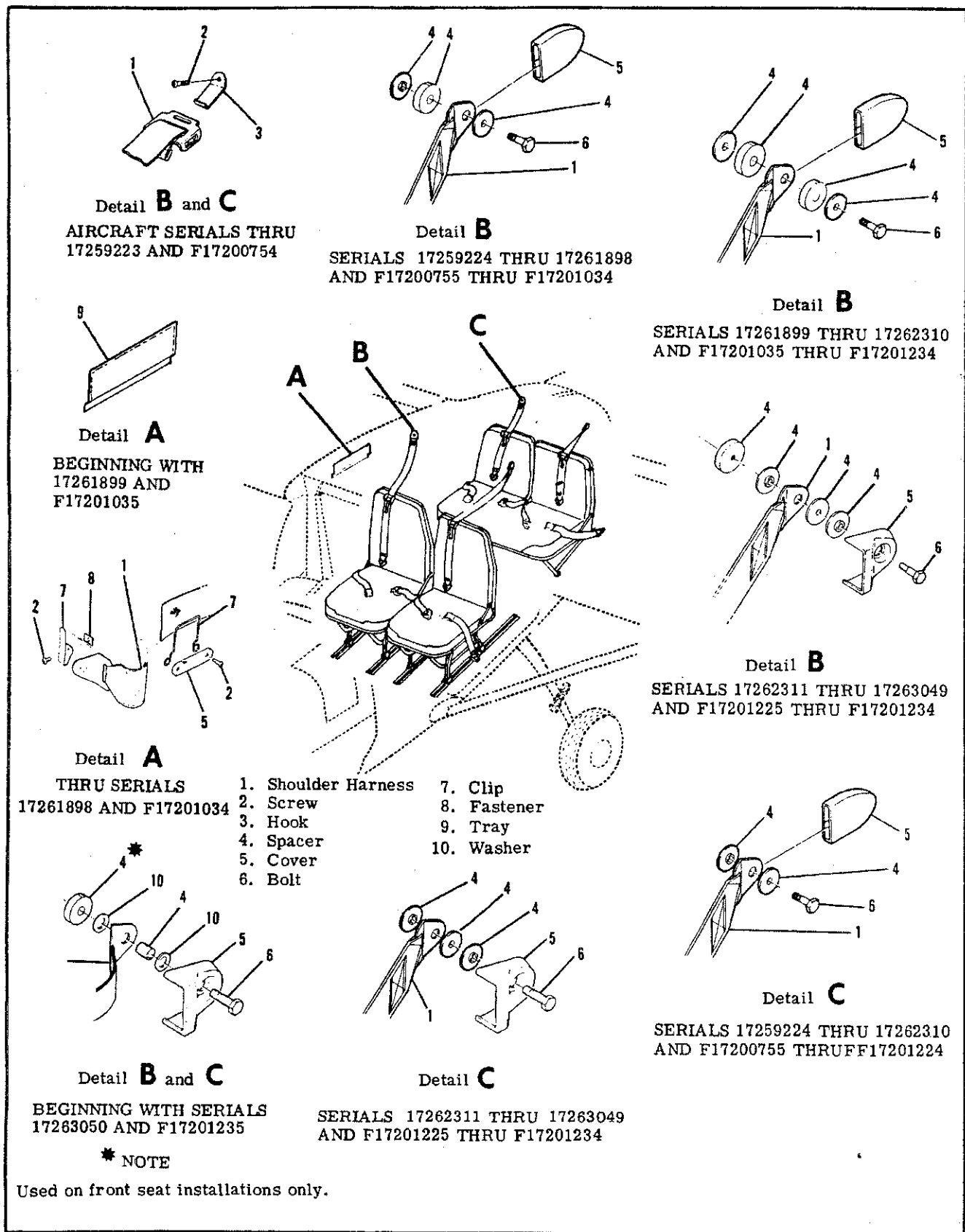

Figure 3-11. Seat Belt and Shoulder Harness Installation (Sheet 1 of 2)

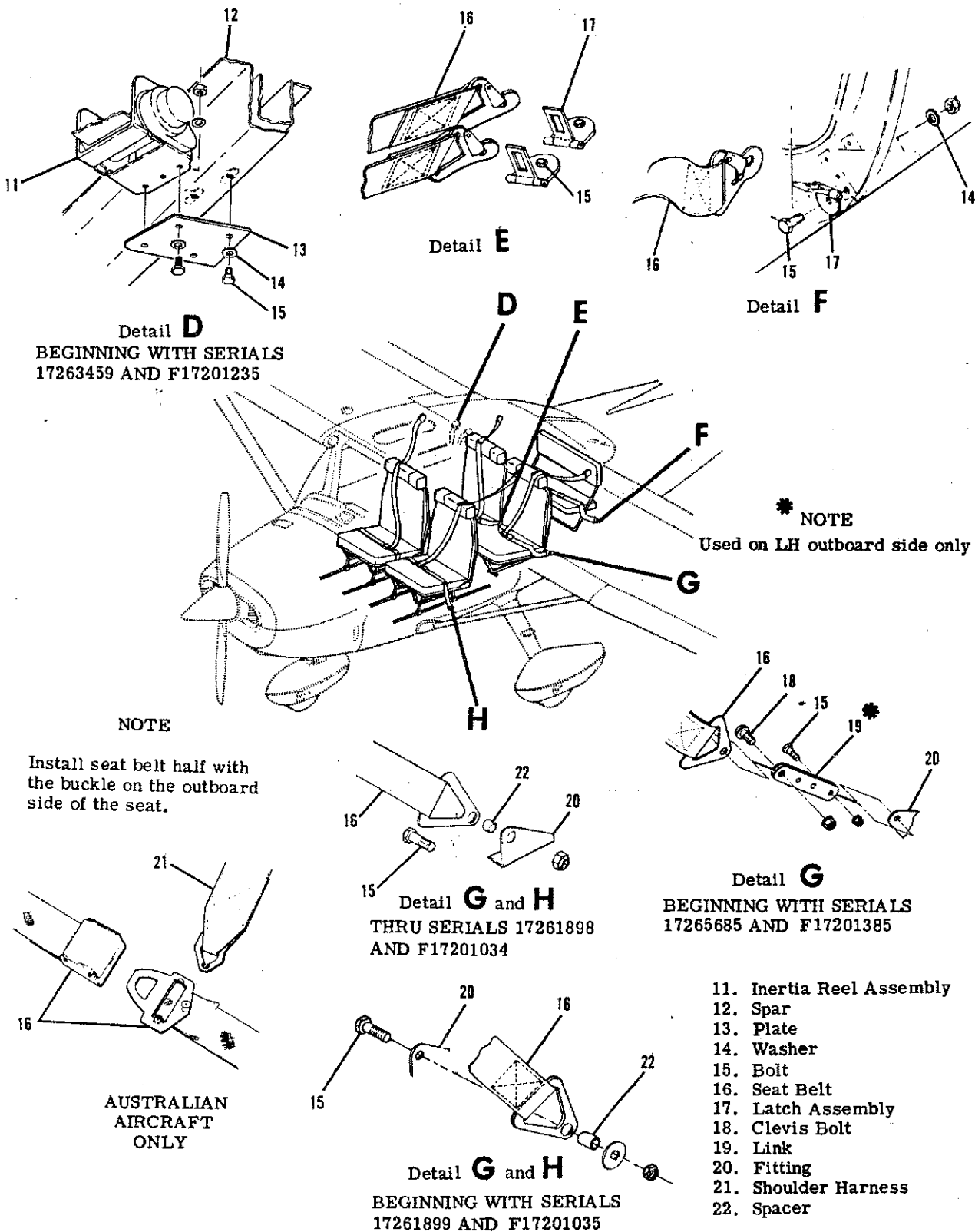

Figure 3-11. Seat Belt and Shoulder Harness Installation (Sheet 2 of 2)

SECTION 4  
WINGS AND EMPENNAGE

TABLE OF CONTENTS	Page		
WINGS AND EMPENNAGE . . . . .	4-1	Description . . . . .	4-3
Wings . . . . .	4-1	Removal . . . . .	4-3
Description . . . . .	4-1	Repair . . . . .	4-4
Removal . . . . .	4-1	Installation . . . . .	4-4
Repair . . . . .	4-3	Horizontal Stabilizer . . . . .	4-4
Installation . . . . .	4-3	Description . . . . .	4-4
Adjustment . . . . .	4-3	Removal and Installation . . . . .	4-4
Wing Struts . . . . .	4-3	Repair . . . . .	4-5
Description . . . . .	4-3	Stabilizer Abrasion Boots . . . . .	4-7
Removal and Installation . . . . .	4-3	Description . . . . .	4-7
Repair . . . . .	4-3	Removal . . . . .	4-7
Fin . . . . .	4-3	Installation . . . . .	4-7

4-1. WINGS AND EMPENNAGE.

4-2. WINGS. (See figure 4-1.)

4-3. DESCRIPTION. Each all-metal wing is a semi-cantilever, semimonocoque type, with two main spars and suitable ribs for the attachment of the skin. Skin panels are riveted to ribs, spars and stringers to complete the structure. An all-metal, piano-hinged aileron, flap and a detachable wing tip are mounted on each wing assembly. A single metal fuel tank is mounted between the wing spars at the inboard end of each wing. The leading edge of the left wing may be equipped with landing and taxi lights (thru 1970 Models). Colored navigation lights are mounted at each wing tip.

4-4. REMOVAL. Wing panel removal is most easily accomplished if four men are available to handle the wing. Otherwise, the wing should be supported with a sling or maintenance stand when the fastenings are loosened.

- a. Remove wing root fairings and fairing plates.
- b. Remove all wing inspection plates.
- c. Drain fuel from tank of wing being removed.
- d. Disconnect:
  1. Electrical wires at wing root disconnects.
  2. Fuel lines at wing root. (Refer to precautions outlined in Section 12.
  3. Pitot line (left wing only) at wing root.
  4. Cabin ventilator hose at wing root.
  5. Wing leveler vacuum tube, if installed, at wing root.
- e. Slack off tension on aileron cables by loosening turnbuckles, then disconnect cables at aileron bell-cranks. Disconnect flap cables at turnbuckles above headliner, and pull cables into wing root area.

NOTE

To ease rerouting the cables, a guide wire may be attached to each cable before it is pulled free of the wing. Cable may then be disconnected from wire. Leave guide wire routed through the wing; it may be attached again to the cable during reinstallation and used to pull the cable into place.

- f. Support wing at outboard end and disconnect strut at wing fitting. Tie the strut up with wire to prevent it from swinging down and straining strut-to-fuselage fitting. Loosen lower strut fairing and slide it up the strut, the strut may then be lowered without damage.

NOTE

It is recommended that flap be secured in streamlined position with tape during wing removal to prevent damage, since flap will swing freely.

- g. Mark position of wing attachment eccentric bushings (refer to figure 4-1); these bushings are used to rig out "wing heaviness."
- h. Remove nuts, washers, bushings and bolts attaching wing spars to fuselage.

NOTE

It may be necessary to rock the wing slightly while pulling attaching bolts, or to use a long drift punch to drive out attaching bolts.

- i. Remove wing and lay on padded stand.

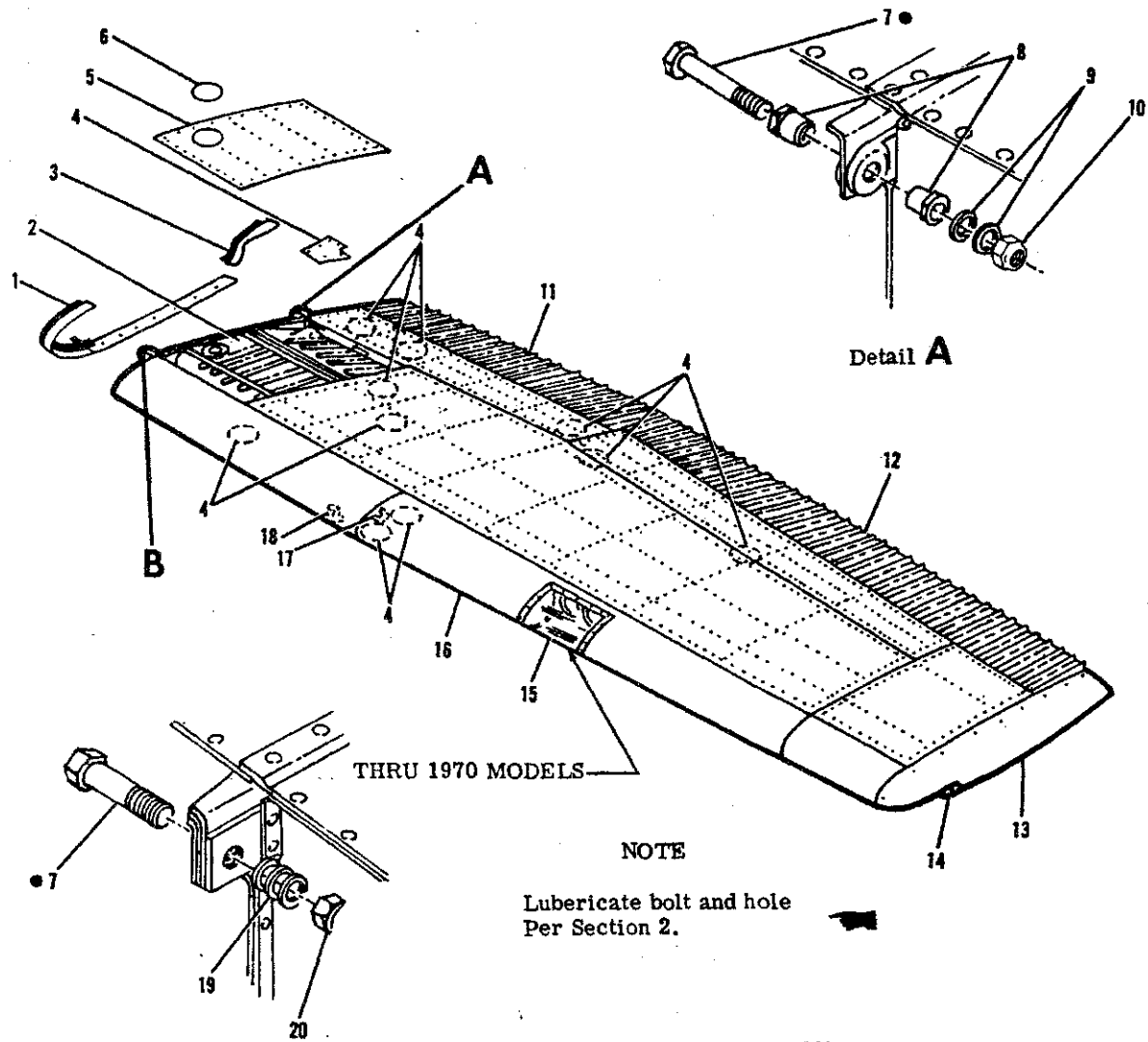

● MINIMUM TORQUE 300 LB-IN.

NOTE  
Lubricate bolt and hole  
Per Section 2.

NOTE  
Three washers (19) are installed under the  
nut on the front spar-to-fuselage fitting.

Beginning with the 1971 Models, the  
landing and taxi lights are located in  
the nose cowl.

- |                           |                                  |
|---------------------------|----------------------------------|
| 1. Fairing                | 11. Wing Flap                    |
| 2. Fuel Tank              | 12. Aileron                      |
| 3. Lower Rear Fairing     | 13. Wing Tip                     |
| 4. Inspection Plate       | 14. Navigation and Strobe Lights |
| 5. Fuel Tank Cover        | 15. Landing and Taxi Lights      |
| 6. Fuel Gage Access Cover | 16. Wing Assembly                |
| 7. Bolt                   | 17. Cover Plate                  |
| 8. Eccentric Bushings     | 18. Stall Warning Unit           |
| 9. Washer                 | 19. Washers                      |
| 10. Nut                   | 20. Nut                          |

Figure 4-1. Wing Installation

4-5. REPAIR. A damaged wing may be repaired in accordance with instructions outlined in Section 18, which supplements Federal Aviation Regulation, Part 43. Extensive repairs of wing skin and structure are best accomplished by using the wing alignment repair jig, which may be obtained from Cessna. The wing jig serves not only as a holding fixture, making work on the wing easier, but also assures absolute alignment of the repaired wing.

#### 4-6. INSTALLATION.

- a. Hold wing in position and install bolts, bushings, washers and nuts attaching wing spars to fuselage fittings. Be sure eccentric bushings are positioned as marked.
- b. Install bolts, spacers, and nuts to secure upper and lower ends of wing strut to wing and fuselage fittings.
- c. Route flap and aileron cables, using guide wires. (See note in paragraph 4-4.)
- d. Connect:
  1. Electrical wires at wing root disconnects.
  2. Fuel lines at wing root. (Refer to precautions outlined in Section 12.)
  3. Pitot line (if left wing is being installed).
  4. Wing leveler vacuum tube, if installed, at wing root.
- e. Rig aileron system. (Section 6.)
- f. Rig flap system (Section 7.)
- g. Refuel wing tank and check for leaks. (Refer to precautions outlined in Section 12.)
- h. Check operation of wing tip lights and landing and taxi lights thru 1970 Models.
- i. Check operation of fuel gage.
- j. Install wing root fairings.

#### NOTE

Be sure to insert soundproofing panel in wing gap, if such a panel was installed originally, before replacing wing root fairings.

- k. Install all wing inspection plates, interior panels and upholstery.

4-7. ADJUSTMENT (CORRECTING "WING-HEAVY" CONDITION.) (Refer to figure 4-1.) If considerable control wheel pressure is required to keep the wings level in normal flight, a wing-heavy condition exists.

- a. Remove wing fairing strip on the wing-heavy side of the aircraft.
- b. Loosen nut (10) and rotate bushings (8) simultaneously until the bushings are positioned with the thick side of the eccentrics up. This will lower the trailing edge of the wing, and decrease wing-heaviness by increasing angle-of-incidence of the wing.

#### CAUTION

Be sure to rotate the eccentric bushings simultaneously. Rotating them separately will destroy the alignment between the off-center bolt holes in the bushings, thus exerting a shearing force on the bolt, with possible damage to the hole in the wing spar.

- c. Tighten nut and reinstall fairing strip.

- d. Test-fly the aircraft. If the wing-heavy condition still exists, remove fairing strip on the "lighter" wing, loosen nut, and rotate bushings simultaneously until the bushings are positioned with the thick side of the eccentrics down. This will raise the trailing edge of the wing, thus increasing wing-heaviness to balance heaviness in the opposite wing.

- e. Tighten nut, install fairing strip, and repeat test flight.

#### 4-8. WING STRUTS. (Refer to figure 4-2.)

4-9. DESCRIPTION. Each wing has a single lift strut which transmits a part of the wing load to the lower portion of the fuselage. The strut consists of a streamlined tube riveted to two end fittings for attachment at the fuselage and wing.

#### 4-10. REMOVAL AND INSTALLATION.

- a. Remove screws from strut fairings and slide fairings along strut.
- b. Remove fuselage and wing inspection plates at strut junction points.
- c. Support wing securely, then remove nut and bolt securing strut to fuselage.
- d. Remove nut, bolt, and spacer used to attach strut to wing, then remove strut from aircraft.
- e. Reverse preceding steps to install strut.

4-11. REPAIR. Wing strut repair is limited to replacement of tie-downs and attaching parts. A badly dented, cracked, or deformed wing strut should be replaced.

#### 4-12. FIN. (Refer to figure 4-3.)

4-13. DESCRIPTION. The fin is primarily of metal construction, consisting of ribs and spars covered with skin. Fin tips are of ABS construction. Hinge brackets at the fin rear spar attach the rudder.

4-14. REMOVAL. The vertical fin on the Models 172 and F172 may be removed without first removing the rudder. However, for access and ease of handling, the rudder may be removed by following procedures outlined in Section 10.

- a. Remove fairings on either side of fin.
- b. Disconnect flashing beacon lead, tail navigation light lead, antennas and antenna leads, and rudder cables, if rudder has not been removed.

#### NOTE

The flashing beacon electric lead that routes into the fuselage may be cut, then spliced (or quick-disconnects used) at installation.

- c. Remove screws attaching dorsal to fin.
- d. Disconnect elevator cable from elevator bell-crank.
- e. Remove bolts attaching fin rear spar to fuselage fitting. Remove upper elevator stop bolts.
- f. Remove bolts attaching fin front spar to fuselage bulkhead, and remove fin.
- g. Retain any shims installed between the rear spar of the fin and the fuselage fitting.

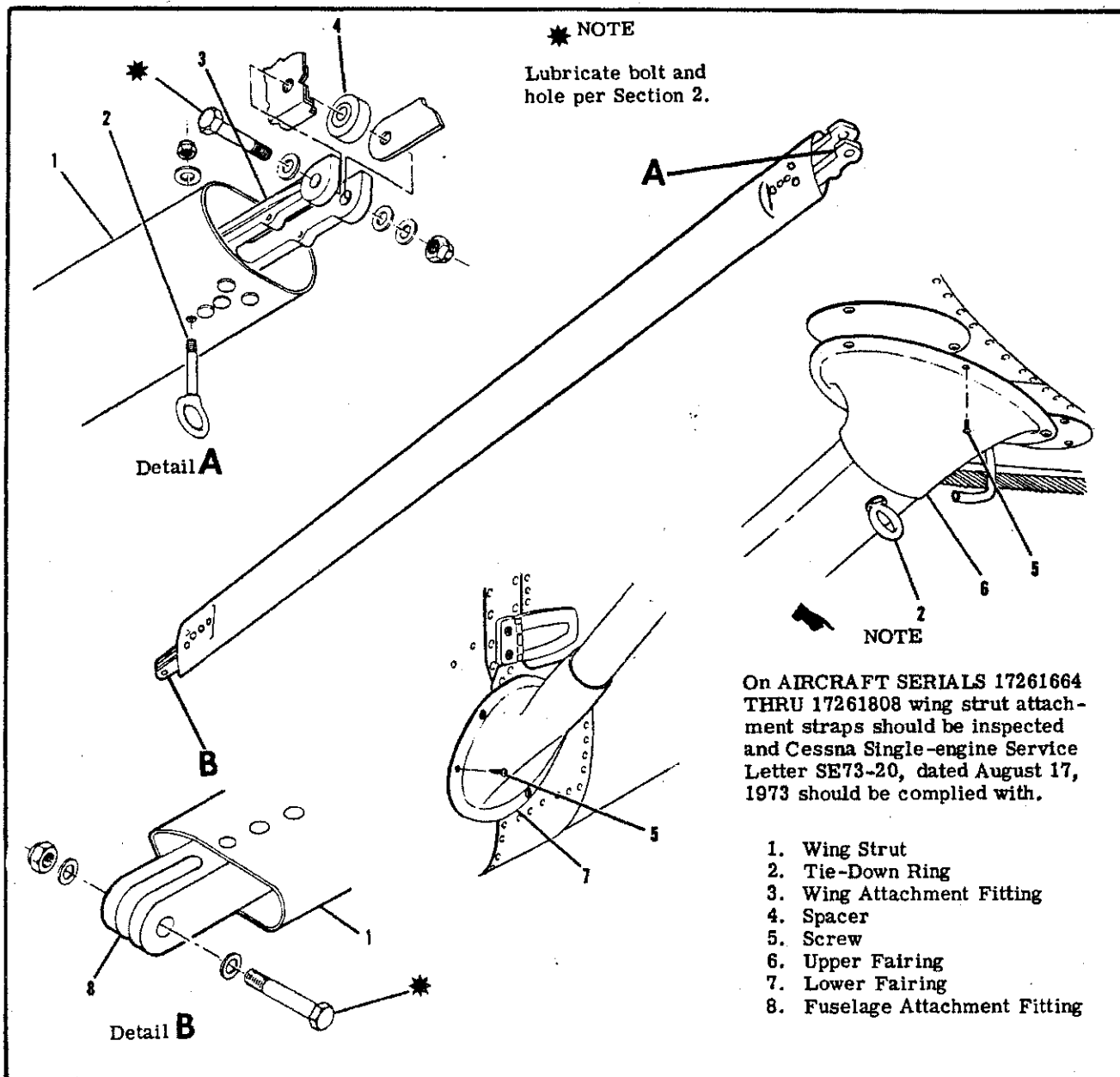

Figure 4-2. Wing Strut

4-15. REPAIR. Fin repair should be accomplished in accordance with applicable instructions outlined in Section 18.

4-16. INSTALLATION. Reverse the procedures outlined in paragraph 4-14 to install the vertical fin. Be sure to check and reset rudder and elevator travel.

- a. Reinstall any shims removed from between the fin rear spar and the fuselage fitting. If a new fin is being installed, measure any gap existing between the fin rear spar and the fuselage fitting and use shims as follows:
- |                              |                         |
|------------------------------|-------------------------|
| .000" to .030" gap . . . . . | No Shim                 |
| .030" to .050" gap . . . . . | .0531115-1 Shim (.020") |
| .050" to .070" gap . . . . . | .0531115-2 Shim (.040") |

A maximum of one shim per bolt is permissible.

4-17. HORIZONTAL STABILIZER. (See figure 4-4.)

4-18. DESCRIPTION. The horizontal stabilizer is primarily of all-metal construction, consisting of ribs and spars covered with skin. Stabilizer tips are of ABS construction. A formed metal leading edge is riveted to the assembly to complete the structure. The elevator trim tab actuator is contained within the horizontal stabilizer. The underside of the stabilizer contains a covered opening which provides access to the actuator. Hinges are located on the rear spar assembly to support the elevators.

4-19. REMOVAL AND INSTALLATION.

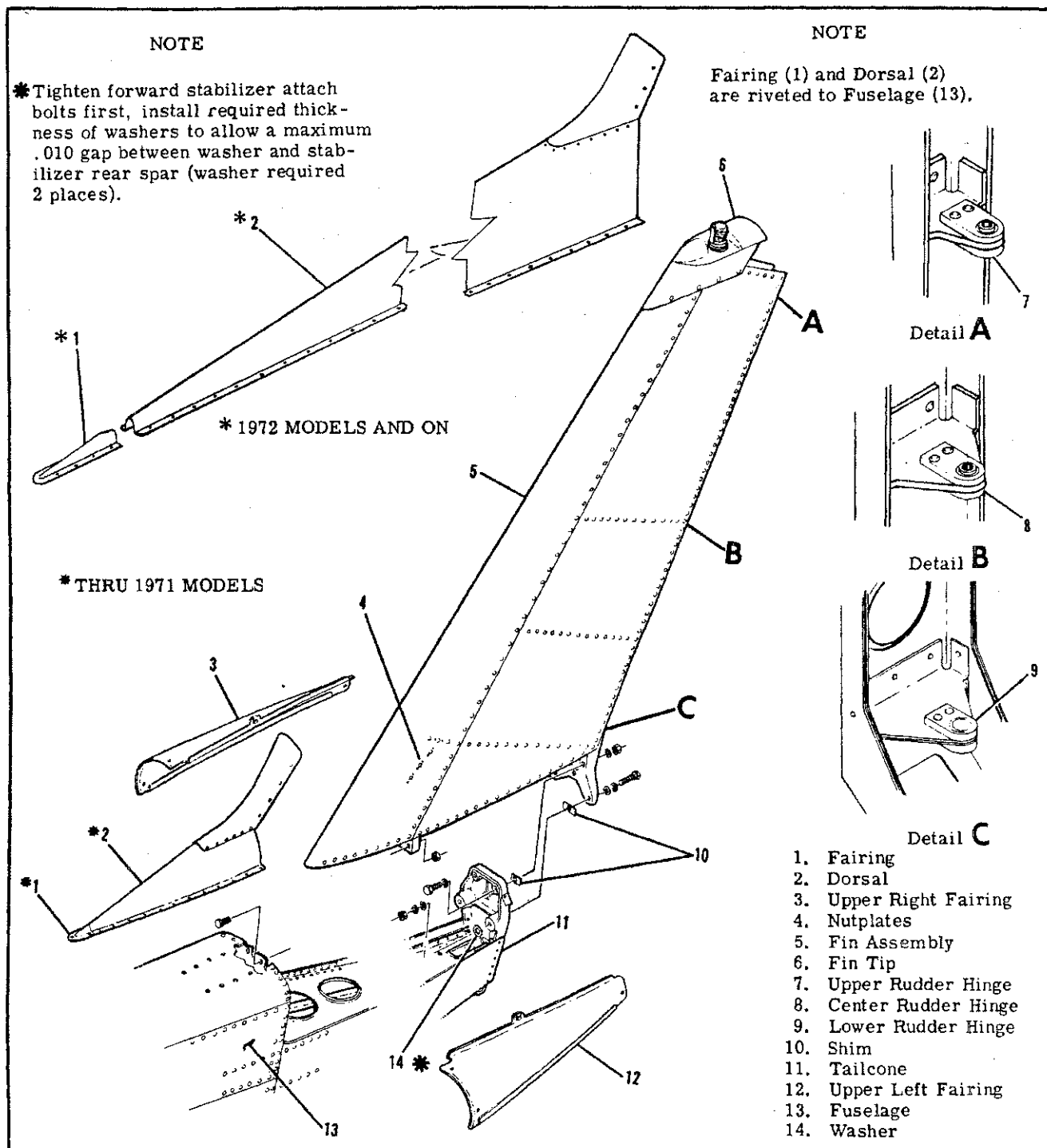

Figure 4-3. Vertical Fin

- Remove elevators and rudder in accordance with procedures outlined in Sections 8 and 10.
- Remove vertical fin in accordance with procedures outlined in paragraph 4-14.
- Disconnect elevator trim control cables at clevis and turnbuckle inside tailcone, remove pulleys which route the aft cables into horizontal stabilizer, and pull cables out of tailcone.
- Remove bolts securing horizontal stabilizer to

fuselage.

- Remove horizontal stabilizer.
- Reverse preceding steps to install horizontal stabilizer. Rig control systems as necessary, check operation of tail navigation light and flashing beacon.

4-20. **REPAIR.** Horizontal stabilizer repair should be accomplished in accordance with applicable instructions in Section 18.

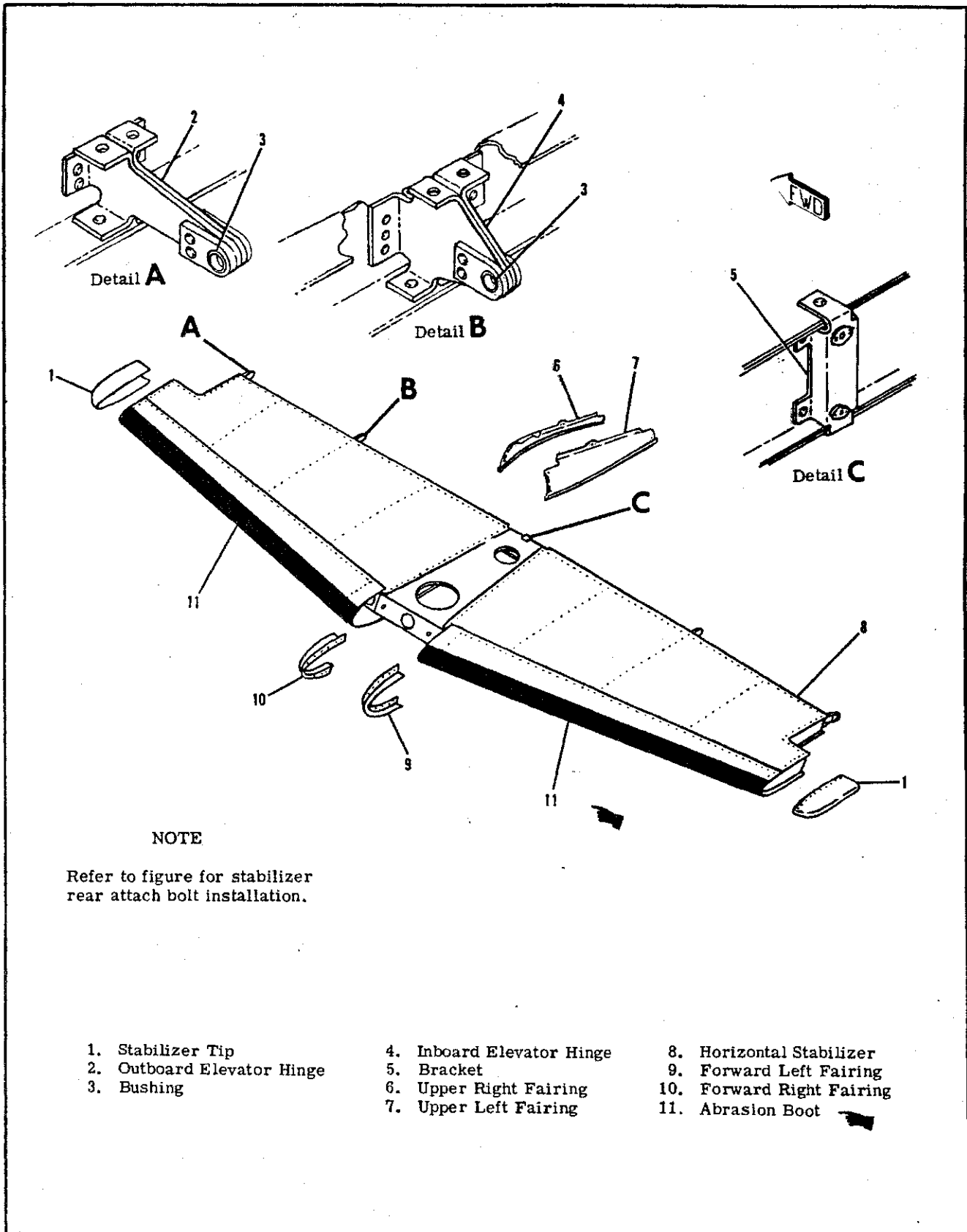

Figure 4-4. Horizontal Stabilizer



SECTION 5

LANDING GEAR AND BRAKES

TABLE OF CONTENTS

	Page		
LANDING GEAR . . . . .	5-1	Nose Wheel Removal and Installation . . . . .	5-17
General Description . . . . .	5-1	Disassembly (Cleveland) . . . . .	5-17
Trouble Shooting . . . . .	5-2	Inspection and Repair (Cleveland) . . . . .	5-18
Main Gear . . . . .	5-2	Reassembly (Cleveland) . . . . .	5-18
Removal (Flat Gear) . . . . .	5-3	Disassembly (McCauley Wheel with	
Installation (Flat Gear) . . . . .	5-3	Thru-bolts) . . . . .	5-18A
Removal (Tubular Gear) . . . . .	5-3	Inspection and Repair (McCauley	
Installation (Tubular Gear) . . . . .	5-3	Wheel with Thru-bolts) . . . . .	5-18A
Step Bracket Installation . . . . .	5-3	Reassembly (McCauley Wheel with	
Main Wheel Speed Fairing Removal		Thru-bolts) . . . . .	5-18A
and Installation . . . . .	5-6	Disassembly (McCauley Wheel with	
Removal and Installation of Main		Capscrews) . . . . .	5-18A
Landing Gear Fairing . . . . .	5-6	Inspection and Repair (McCauley	
Main Wheel Removal . . . . .	5-8	Wheel with Capscrews) . . . . .	5-18A
Disassembly (Cleveland) . . . . .	5-8	Reassembly (McCauley Wheel with	
Inspection and Repair (Cleveland) . . . . .	5-8	Capscrews) . . . . .	5-18A
Reassembly (Cleveland) . . . . .	5-8	Wheel Balancing . . . . .	5-19
Disassembly (McCauley Wheel) . . . . .	5-8A	Nose Gear Shock Strut Disassembly . . . . .	5-19
Inspection and Repair (McCauley		Nose Gear Shock Strut Reassembly . . . . .	5-19
Wheel) . . . . .	5-8A	Torque Links . . . . .	5-21
Reassembly (McCauley Wheel-		Shimmy Dampener . . . . .	5-21
Aluminum Flange) . . . . .	5-8A	Nose Wheel Steering System . . . . .	5-22
Reassembly (McCauley Wheel-		Steering Rod Assembly . . . . .	5-22
Steel Flange) . . . . .	5-8A	Nose Wheel Steering Adjustment . . . . .	5-22
Main Wheel Installation . . . . .	5-8B	Brake System . . . . .	5-23
Main Wheel Axle Removal (Flat Gear) . . . . .	5-9	General Description . . . . .	5-23
Main Wheel Axle Installation		Trouble Shooting . . . . .	5-23
(Flat Gear) . . . . .	5-11	Brake Master Cylinders	
Main Wheel Axle Removal (Tubular		Removal and Installation . . . . .	5-24
Gear) . . . . .	5-11	Repair . . . . .	5-24
Main Wheel Axle Installation (Tubular		Hydraulic Brake Lines . . . . .	5-24
Gear) . . . . .	5-11	Wheel Brake Assemblies . . . . .	5-24
Main Wheel Alignment (Flat Gear) . . . . .	5-11	Removal . . . . .	5-24
Main Wheel Alignment (Tubular		Inspection and Repair . . . . .	5-24
Gear) . . . . .	5-11	Reassembly . . . . .	5-24
Wheel Balancing . . . . .	5-11	Installation . . . . .	5-24
Nose Gear . . . . .	5-11	Checking Brake Lining Wear . . . . .	5-24
Trouble Shooting . . . . .	5-14	Brake Lining Installation . . . . .	5-24
Nose Gear Removal and Installation . . . . .	5-14	Brake System Bleeding . . . . .	5-26
Nose Wheel Speed Fairing Removal		Parking Brake System . . . . .	5-26
and Installation . . . . .	5-14		

5-1. LANDING GEAR.

5-2. DESCRIPTION. On 1969-1970 Model aircraft, a non-retractable tricycle landing gear equipped with Cessna flat spring-steel main gear struts and an air/oil steerable nose gear shock strut are used. Beginning with 1971 Model aircraft, a non-retractable tricycle landing gear equipped with Cessna tubular spring-steel main gear struts and an air/oil steerable nose gear shock strut are used. A bracket to attach a step to each strut is bonded to the main gear strut with a thermo-setting, high-strength cement. Wheels with disc-type brakes and tube-type tires are install-

ed. The brake disc is attached with the wheel thru-bolts or capscrews and becomes an integral part of the wheel. The nose gear is a combination of a conventional air/oil (oleo) strut and fork, incorporating a shimmy dampener. The nose wheel is steerable with the rudder pedals up to a maximum pedal deflection, after which it becomes free-swiveling up to a maximum travel of 30 degrees right or left of center. Through use of the brakes, the aircraft can be pivoted about the outer wing strut fittings. Speed fairings for the nose and main wheels are available for installation. A heavy-duty nose gear may be installed on some aircraft.

5-3. TROUBLE SHOOTING.

TROUBLE	PROBABLE CAUSE	REMEDY
AIRCRAFT LEANS TO ONE SIDE.	Incorrect tire inflation.	Inflate to pressure specified in figure 1-1.
	Landing gear attaching parts not tight.	Tighten loose parts and replace defective parts.
	Landing gear spring excessively sprung.	Remove and install new parts.
	Incorrect shimming at inboard end of spring. (Flat Gear)	Install shims as required. Refer to paragraph 5-6 for limitations.
	Bent axles.	Replace axles.
TIRES WEAR EXCESSIVELY.	Incorrect tire inflation.	Inflate to pressure specified in figure 1-1.
	Main wheels out of alignment. (Flat Gear)	Align in accordance with paragraph 5-22.
	Main wheels out of alignment. (Tubular Gear)	Remove and install new part(s).
	Landing gear spring excessively sprung.	Remove and install new parts.
	Incorrect shimming at inboard end of spring. (Flat Gear)	Install shims as required. Refer to paragraph 5-6 for limitations.
	Bent axles.	Replace axles.
	Dragging brakes.	Refer to paragraph 5-42.
	Wheel bearings too tight.	Adjust properly.
	Wheels out of balance.	Correct in accordance with paragraph 5-23.
	Loose torque links.	Add shims or install new parts as required.
WHEEL BOUNCE EVIDENT EVEN ON SMOOTH SURFACE.	Out of balance condition.	Correct in accordance with paragraph 5-23.

5-4. MAIN GEAR. The main gear used on the 1969-1970 Model year aircraft is the flat-spring-steel strut shown on sheet 1 of figure 5-1. The main gear used beginning with 1971 Models is the tubular spring-steel strut shown on sheet 2 of figure 5-1.

The illustrations should be used in conjunction with the following procedures during removal and installation of component parts. Disassembly, inspection and repair, and reassembly of the various main wheel configurations are described in separate paragraphs for each configuration. The solid wheels having two wheel halves are manufactured by Cleveland Aircraft

Products Co. and webbed wheels having two flanges and a hub are manufactured by McCauley Industrial Corporation. The Cleveland wheels are shown in figure 5-3. The McCauley wheels have either aluminum flanges or steel flanges as shown in figure 5-3A. The aluminum flanges are attached to the wheel hub by thru-bolts and nuts as shown in figure 5-3A and the steel flanges are attached to the wheel hub by cap-screws as shown in figure 5-3A. During assembly of the main wheels the thru-bolt nuts or capscrews, as applicable, shall be tightened evenly and torqued to the value specified in figure 5-2A.

5-5. REMOVAL. (FLAT.) (See sheet 1 of figure 5-1.) The following procedural steps remove the landing gear as a complete assembly. Refer to applicable paragraphs for removal of the individual components.

- a. Remove floorboard access covers over spring-strut being removed.
- b. Hoist or jack aircraft in accordance with Section 2.
- c. Remove screws and slide external fairing plate and seal down around spring strut.
- d. Drain hydraulic brake fluid from brake line on spring-strut being removed.
- e. Disconnect hydraulic brake line at bulkhead fitting inboard end of spring-strut so that brake line is removed with the spring-strut. Cap or plug disconnected fitting to prevent entry of foreign material.
- f. Remove nuts and washers from U-bolt at outboard attaching structure and remove U-bolt.
- g. Remove bolt attaching the inboard end of the spring-strut and pull entire gear out of fuselage. Note shims placed under inboard end of the spring-strut and mark or tape shims together to be sure they are installed correctly at installation of the spring-strut.

5-6. INSTALLATION. (FLAT.) (See sheet 1 of figure 5-1.) The following procedural steps install the landing gear as a complete assembly. Refer to applicable paragraphs for installation of the individual components.

- a. Slide external fairing plate and seal over upper end of landing gear spring-strut.
- b. Slide the spring-strut into place and work shims into position under inboard end of spring-strut. Install bolt, washer, and nut to secure inboard end of spring-strut.

#### NOTE

Shims are installed under inboard end of the spring-strut as required to level the wings within a total tolerance of three inches. Maximum number of shims permissible is two.

- c. Install U-bolt at outboard attaching structure with washers and nuts. Tighten nuts evenly to 270-300 lb-in. Also torque inboard attach bolt to specified torque of 1100-1300 lb-in.
- d. Attach seal and external fairing with screws.
- e. Lower aircraft and remove jacks or hoist.
- f. Connect brake line; fill and bleed brake system as outlined in paragraph 5-54.
- g. Install floorboard access covers.

5-7. REMOVAL (TUBULAR). (See sheet 2 of figure 5-1.) The following procedural steps remove the landing gear as a complete assembly. Refer to ap-

plicable paragraphs for removal of the individual components.

- a. Remove floorboard access covers over spring-strut being removed.
- b. Hoist or jack aircraft in accordance with Section 2.
- c. Remove screws attaching fairing to fuselage and remove screw at splice in fairing and remove fairing.
- d. Drain hydraulic brake fluid from brake line on spring-strut being removed.
- e. Disconnect hydraulic brake line in fuselage so that brake line is removed with the spring-strut. Cap or plug disconnected fittings to prevent entry of foreign material.
- f. Remove nut, washer, and bolt attaching inboard end of spring-strut to the inboard landing gear bulkhead fitting.
- g. Pull landing gear from fitting and bushing. Use care when removing landing gear to prevent damage to the hydraulic brake line. The landing gear is a compression fit in the bushing in the outboard landing gear bulkhead.

5-8. INSTALLATION. (TUBULAR.) (See sheet 2 of figure 5-1.) The following procedural steps install the landing gear as a complete assembly. Refer to applicable paragraphs for installing the individual components.

- a. Re-install all parts removed from spring-strut.
- b. Apply Dow Corning Compound DC7 to approximately 11 inches on upper end of spring-strut.
- c. Work spring-strut into place through bushing in outboard spring-strut fitting and into spring-strut inboard fitting.
- d. Align spring-strut in inboard fitting and install bolt through fitting and spring-strut. Install washer and nut on bolt and tighten to torque value of 1100-1300 lb-in.
- e. Connect hydraulic brake line to fitting. Fill and bleed brake system in accordance with paragraph 5-54.
- f. Install fairing.
- g. Lower aircraft and install floorboard access covers.

5-9. STEP BRACKET INSTALLATION.

#### NOTE

The step bracket is secured to the landing gear spring-strut with EA9309, or a similar epoxy base adhesive.

- a. Remove landing gear strut fairing, if installed.
- b. Mark position of the step bracket so that the new step bracket will be installed in approximately the same position on the strut.

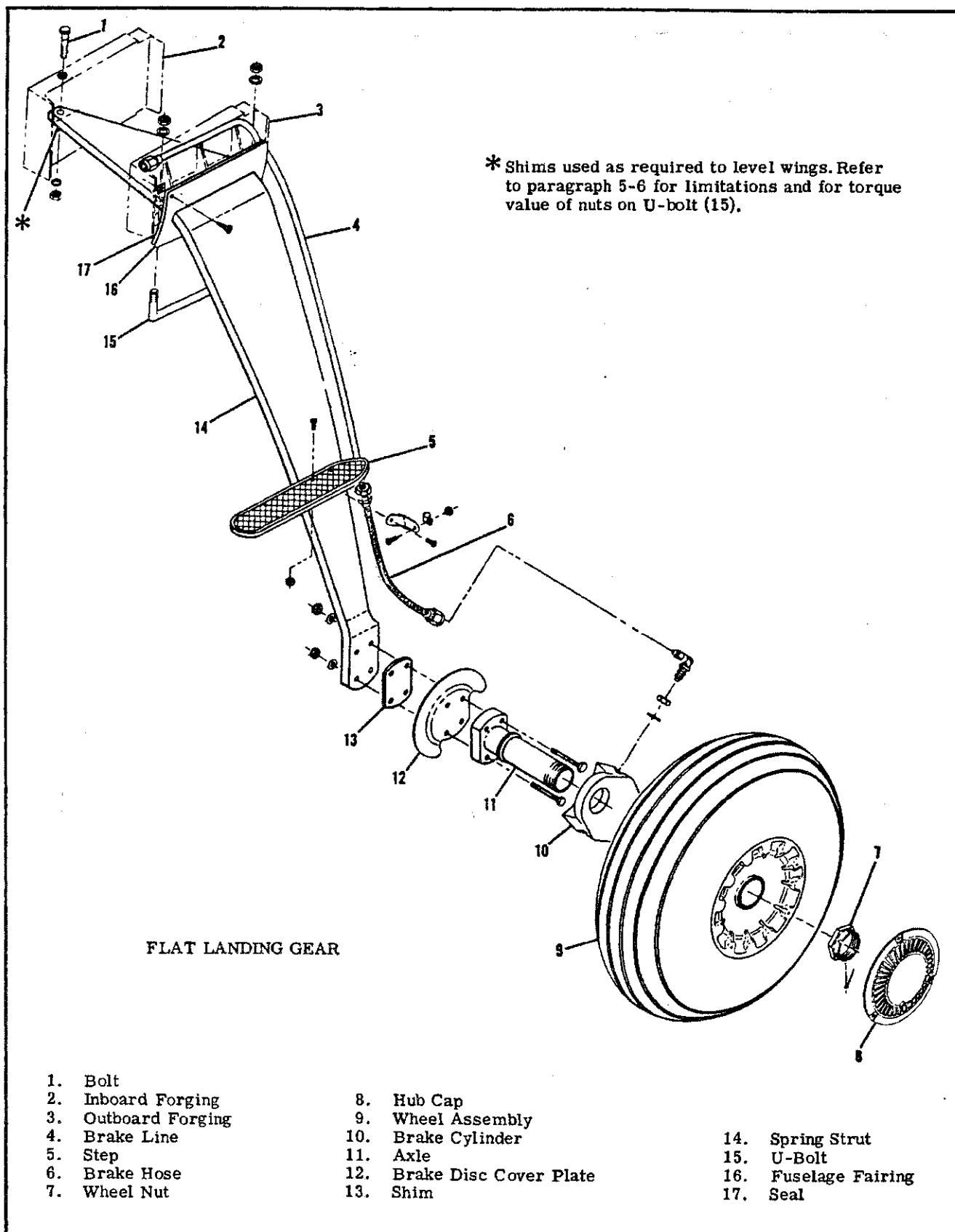

Figure 5-1. Main Gear Installation (Sheet 1 of 2)

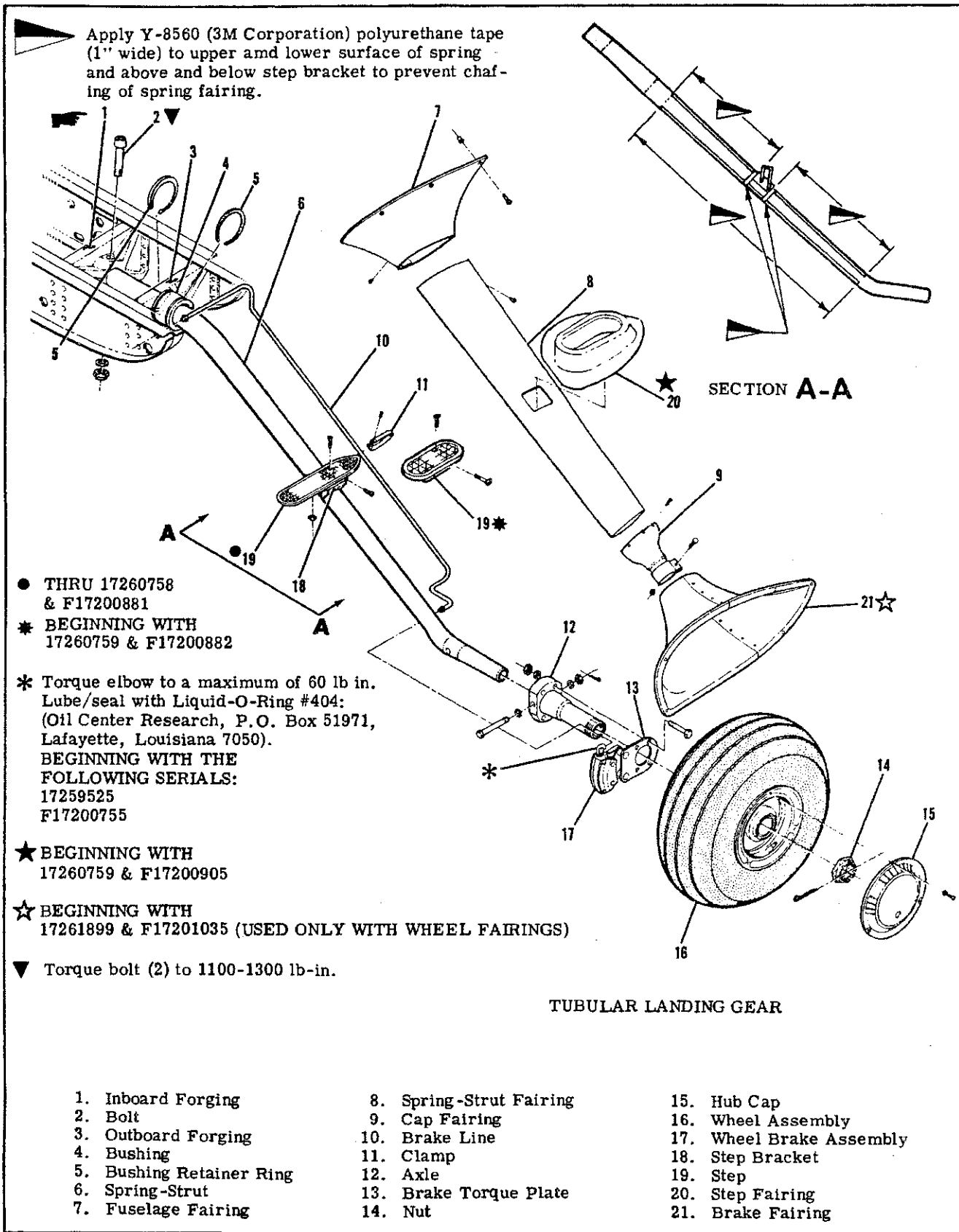

Figure 5-1. Main Gear Installation (Sheet 2 of 2)

c. Remove all traces of the original bracket and adhesive as well as any rust, paint, or scale with a wire brush and coarse sandpaper.

d. Leave surfaces of strut slightly roughened or abraded, but deep scratches or nicks should be avoided. Also roughen the bonding surface of the new bracket.

e. Clean surfaces to be bonded together thoroughly. If a solvent is used, remove all traces of the solvent with a clean, dry cloth. It is important that the bonding surfaces be clean and thoroughly dry.

f. Check fit of the step bracket on the spring strut. A small gap is permissible between the bracket and spring strut.

g. Mix adhesive (EA9309) in accordance with manufacturer's directions.

h. Spread a coat of mixed adhesive on bonding surfaces of strut and bracket, and place step bracket in position on the spring strut. On the flat spring gear strut, tap bracket upward on the spring strut to insure a good tight fit. On the tubular spring strut, clamp bracket to strut to insure a good fit. Be sure the bracket is straight on the strut.

i. Form a small fillet of the adhesive at all edges of the bonding surfaces. Remove excess adhesive with lacquer thinner.

j. Allow the adhesive to thoroughly cure according to the manufacturer's recommendations before flexing the gear spring strut or apply loads to the step.

k. Paint gear spring strut and step bracket after the curing is completed.

l. Install landing gear strut fairing, if installed, and install step to bracket.

#### 5-10. MAIN WHEEL SPEED FAIRING REMOVAL AND INSTALLATION. (Refer to figure 5-2.)

a. Prior to 1974 Models, remove screws attaching stiffener and inboard side of wheel speed fairing to attach plate, which is bolted to the axle.

#### NOTE

Beginning with 1974 Models, remove wheel brake fairing by removing screws around perimeter of fairing, then removing screws from nutplates holding two halves of brake fairing together. Then, accomplish instructions outlined in step "a".

b. Remove bolt securing outboard side of fairing to axle nut.

c. Loosen scraper, if necessary, and work speed fairing from the wheel.

d. Reverse preceding steps to install wheel speed fairing.

e. After installation, check scraper-to-tire clearance for a minimum of 0.25-inch to a maximum of 0.38-inch. Elongated holes are provided in the scraper for clearance adjustment.

#### NOTE

Refer to Cessna Service Kit SK182-12 for repair of wheel speed fairings used on 1969 - 1970 Model aircraft.

#### CAUTION

Always check scraper-to-tire clearance after installing speed fairing, whenever a tire has been changed, and whenever scraper adjustment has been disturbed. If the aircraft is flown from surfaces with mud, snow, or ice, the speed fairing should be checked to make sure there is no accumulation which could prevent normal wheel rotation. Wipe fuel and oil from the speed fairings to prevent stains and deterioration.

#### 5-10A. REMOVAL AND INSTALLATION OF MAIN LANDING GEAR FAIRINGS. (Refer to figure 5-1.)

a. To remove brake fairing, proceed as follows:

1. Remove screws from perimeter of fairing.

2. Remove screws from nutplates holding two halves of fairing together; remove two fairing halves.

3. Reverse preceding steps to install brake fairing.

b. To remove cap fairing, proceed as follows:

1. Remove (3) screws attaching fairing to spring-strut fairing.

2. Remove bolt and nut attaching clamp to spring-strut.

3. Spring clamp open to slide over spring-strut; remove fairing.

c. To remove fuselage fairing, proceed as follows:

1. Remove screws attaching fairing to fuselage.

2. Slide fairing down spring-strut fairing.

3. Reverse preceding steps to install fuselage fairing.

d. To remove step and step fairing, proceed as follows:

1. Remove screw from top of step.

2. Depress fairing for access to (2) screws in base of step; remove screws and step.

3. Remove step fairing over step bracket.

4. Reverse preceding steps to install step and step fairing.

#### NOTE

The step fairing is formed of polyurethane flexible integral skin, which can be stretched to clear step or step bracket. The material will return to its formed shape.

e. To remove spring-strut fairing, proceed as follows:

1. Remove brake fairing as outlined in step "a".

2. Remove cap fairing as outlined in step "b".

3. Remove fuselage fairing as outlined in step "c".

4. Remove step and step fairing as outlined in step "d".

5. Remove screws from "U"-type sheet spring nuts (thru 17260308 and F172-0079); nutplates (beginning with 17260309 and F172-0080).

6. Spring fairing over tubular spring-strut.

7. Reverse preceding steps to install strut fairing.

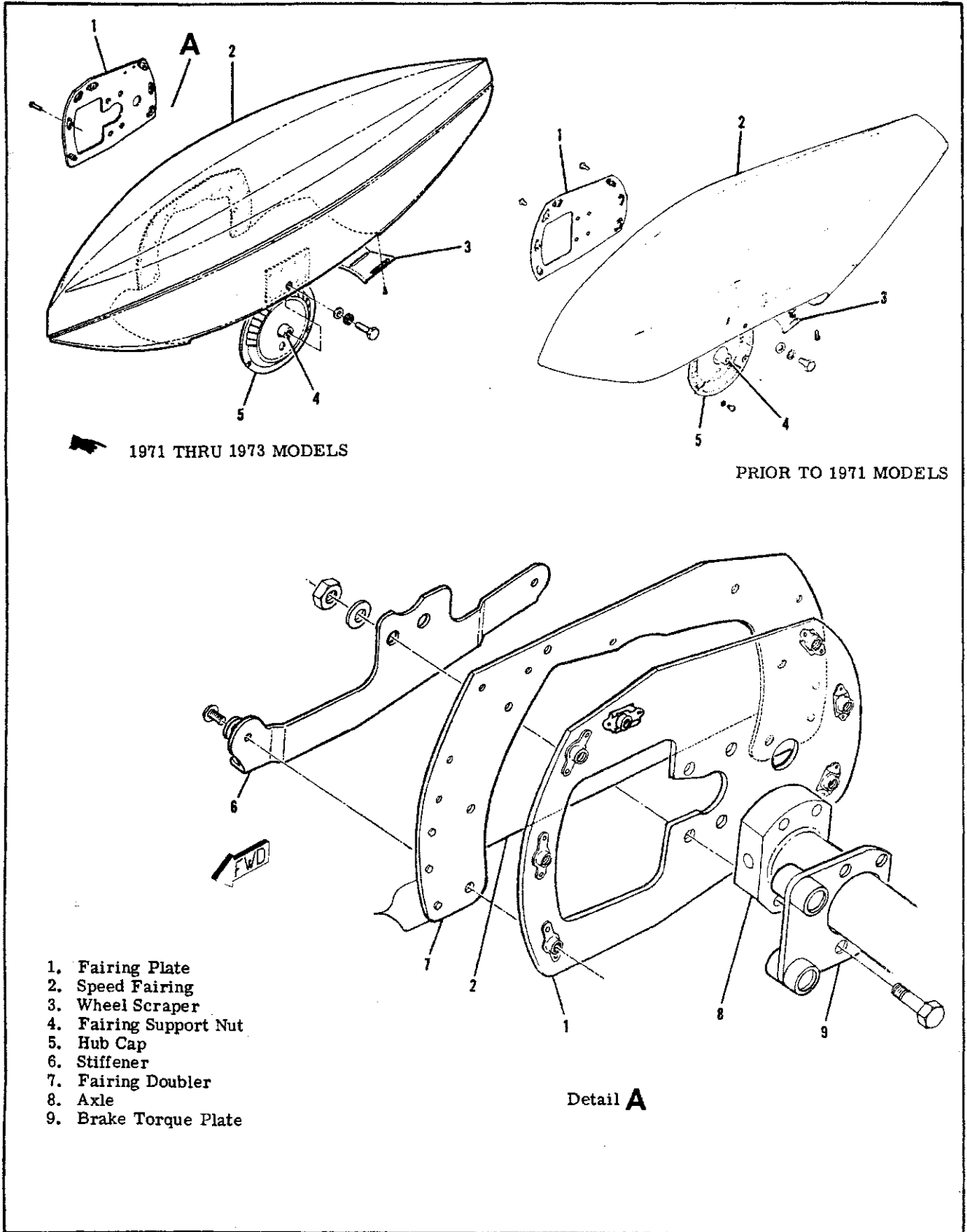

Figure 5-2. Main Wheel Speed Fairing (Sheet 1 of 2)

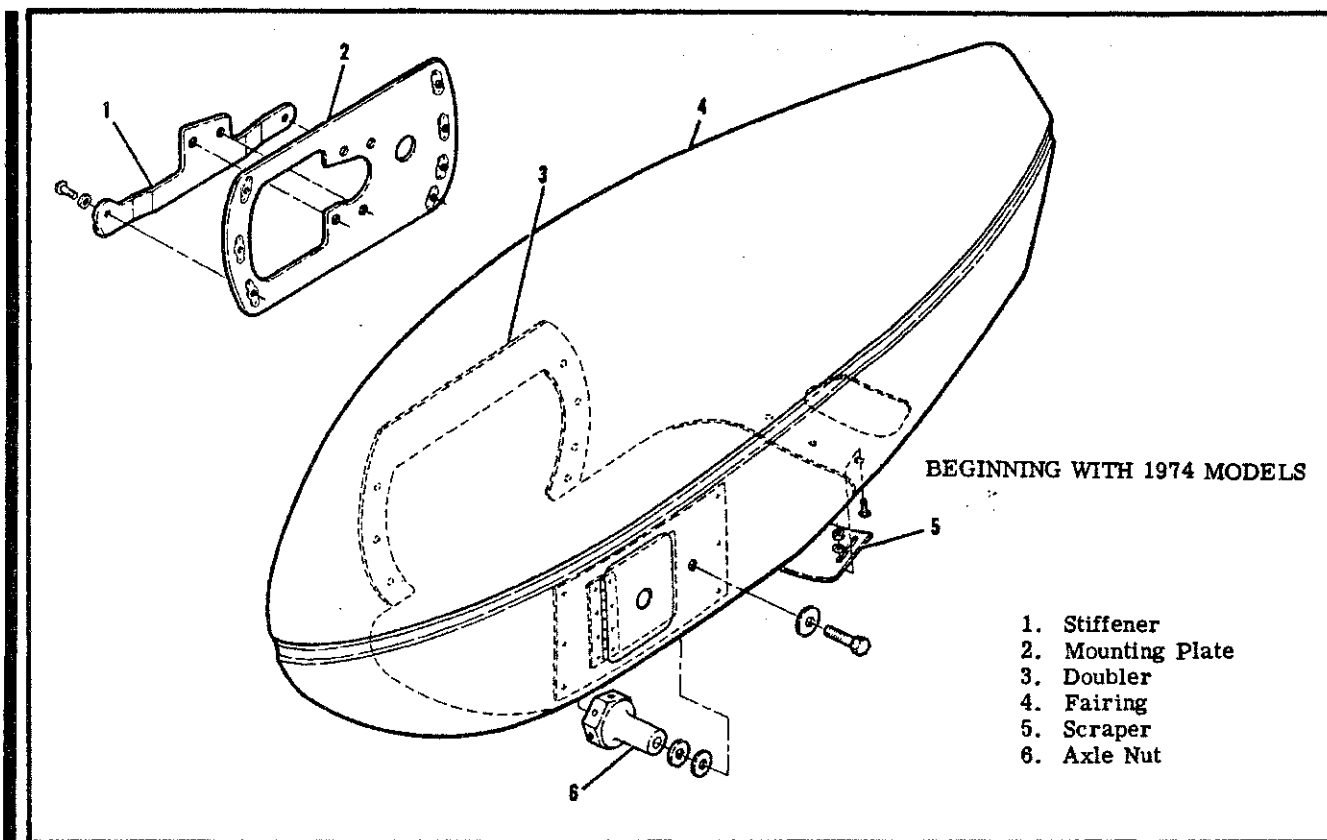

Figure 5-2. Main Wheel Speed Fairing (Sheet 2 of 2)

5-11. MAIN WHEEL REMOVAL. (See figure 5-1.)

NOTE

NOTE

It is not necessary to remove the main wheel to reline brakes or remove brake parts, other than the brake disc.

- a. Hoist or jack aircraft as outlined in Section 2.
- b. Remove speed fairing, if installed, in accordance with paragraph 5-10.
- c. Remove hub cap, cotter pin and axle nut.
- d. Remove bolts and washers attaching brake back plate to brake cylinder and remove back plate.
- e. Pull wheel from axle.

5-12. MAIN WHEEL DISASSEMBLY. (Cleveland).

- a. Remove valve core and deflate tire. Break tire beads loose from wheel rims.

**WARNING**

Injury can result from attempting to separate wheel halves with the tire inflated. Avoid damaging wheel flanges when breaking tire beads loose. A scratch, gouge, or nick in the wheel may cause wheel failure.

- b. Remove thru-bolts and separate wheel halves, removing tire, tube, and brake disc.
- c. Remove the grease seal rings, felts, and bearing cones from the wheel halves.

The bearing cups (races) are a press fit in the wheel halves and should not be removed unless a new part is to be installed. To remove bearing cups, heat wheel halves in boiling water for 30 minutes or in an oven not to exceed 149°C (300°F). Using an arbor press, if available, press out bearing cup and press in the new bearing cup while the wheel half is still hot.

5-13. MAIN WHEEL INSPECTION AND REPAIR.

- a. Clean all metal parts and grease seal felts in solvent and dry thoroughly.
- b. Inspect wheel halves for cracks. Cracked wheel halves shall be discarded and new parts used. Sand out nicks, gouges, and corroded areas. When the protective coating has been removed, the area should be cleaned thoroughly, primed with zinc chromate and painted with aluminum lacquer.
- c. Inspect brake disc. If excessively warped or scored, or worn to a thickness of 0.190-inch, the brake disc should be replaced with a new part. Sand smooth small nicks and scratches.
- d. Carefully inspect bearing cones and cups for damage and discoloration. After cleaning, pack bearing cones with clean aircraft wheel bearing grease (figure 2-5) before installing in wheel half.

5-14. MAIN WHEEL REASSEMBLY. (Cleveland).

- a. Insert thru-bolts through brake disc and position



disc in the inner wheel half, using thru-bolts to guide the disc. Ascertain that the disc is bottomed in the wheel half.

b. Position tire and tube on outboard wheel half with the tube inflation valve through hole in wheel half.

c. Place the inner wheel half in position on outboard wheel half. Apply a light force to bring wheel halves together. While maintaining the light force assemble a washer and nut on thru-bolt and tighten to maintain force. Assemble the remaining washers and nuts to the thru-bolts. Tighten nuts evenly to the torque value stipulated in the chart in figure 5-2A.

### CAUTION

Uneven or improper torque of thru-bolt nuts can cause failure of bolts, with resultant wheel failure.

d. Clean and pack bearing cones with clean aircraft wheel bearing grease (figure 2-5).

e. Assemble bearing cones, grease seal felts, and rings into wheel halves.

f. Inflate tire to seat tire beads, then adjust to correct tire pressure. See figure 1-1.

#### 5-14A. MAIN WHEEL DISASSEMBLY (McCauley Wheel).

a. Remove valve core and deflate tire and tube. Break tire beads loose from wheel flanges.

### WARNING

Injury can result from attempting to remove wheel flanges with the tire and tube inflated. Avoid damaging wheel flanges when breaking tire beads loose. A scratch, gouge or nick in wheel flange could cause wheel failure.

b. Remove thru-bolt nuts and washers or capscrews from outboard wheel flange.

c. Remove thru-bolts and washers or capscrews from inboard wheel flange.

d. Remove brake disc.

e. Separate wheel flanges from wheel hub. Retain spacers on each side of wheel hub.

f. Remove wheel hub from tire.

g. Remove retainer rings and remove grease seal retainers, grease seal felts, and bearing cones.

#### NOTE

The bearing cups (races) are a press fit in the wheel hub and should not be removed unless a new part is to be installed. To remove the bearing cup, heat wheel hub in boiling water for 30 minutes, or in an oven not to exceed 121°C (250°F). Using an arbor press, if available, press out the bearing cup and press in the new bearing cup while the wheel hub is still hot.

#### 5-14B. MAIN WHEEL INSPECTION AND REPAIR. (McCauley Wheel).

a. Clean all metal parts, grease seal felts and mylar spacers in cleaning solvent and dry thoroughly.

b. Inspect wheel flanges, and wheel hub for cracks. Cracked wheel flanges or hub shall be discarded and new parts installed. Sand out smooth nicks, gouges, and corroded areas. When the protective coating has been removed, the area should be cleaned thoroughly, primed with zinc chromate and painted with aluminum lacquer.

c. If excessively warped or scored, or worn to a thickness of 0.190-inch, brake disc should be replaced with a new part. Sand smooth small nicks and scratches.

d. Carefully inspect bearing cones and cups for damage and discoloration. After cleaning, pack bearing cones with clean aircraft wheel bearing grease (Section 2) before installing in wheel hub.

#### 5-14C. MAIN WHEEL REASSEMBLY. (McCauley Wheel - Aluminum Flange).

a. Place wheel hub in tire and tube with tube inflation stem in cutout of wheel hub.

b. Place spacer and wheel flange on inboard side of wheel hub (opposite of tube inflation stem), then with washer under head of thru-bolt, insert bolt thru brake disc, wheel flange, and wheel hub.

c. Place spacer and wheel flange on outboard side of wheel hub with valve inflation stem through cutout in wheel flange.

d. Install washers and nuts on thru-bolts.

### CAUTION

Be sure that spacers and wheel flanges are seated on flange of wheel hub. Uneven or improper torque of thru-bolt nuts can cause failure of bolts, with resultant wheel failure.

e. Tighten thru-bolt nuts evenly and torque to the value stipulated in figure 5-2A.

f. Clean and pack bearing cones with clean aircraft wheel bearing grease. (Refer to Section 2.)

g. Assemble bearing cones, grease seal felts, and retainers into wheel hub.

h. Inflate tire to seat tire beads, then adjust to correct tire pressure. See figure 1-1 for correct tire pressure.

#### 5-14D. MAIN WHEEL REASSEMBLY (McCauley Wheel - Steel Flange).

a. Place wheel hub in tire and tube with tube inflation stem in cutout of wheel hub.

b. Place spacer and wheel flange on inboard side of wheel hub (opposite of tube inflation stem).

c. Place washer under head of each capscrew, insert capscrew thru brake disc, wheel flange, and spacer and start capscrews into wheel hub threads.

**LANDING GEAR WHEEL THRU-BOLT NUT AND CAPSCREW TORQUE VALUES**

MAIN GEAR	NOSE GEAR	WHEEL NUMBER	SIZE	MANUFACTURER	NUT/CAPSCREW TORQUE	WHEEL HALF/FLANGE
X		C163001-0103	6.00 X 6	CLEVELAND	150 lb-in	MAGNESIUM
X		C163001-0104	6.00 X 6	CLEVELAND	90 lb-in	ALUMINUM
X		C163002-0101	6.00 X 6	MC CAULEY	90-100 lb-in	ALUMINUM
X		C163003-0101	6.00 X 6	MC CAULEY	*190-200 lb-in	STEEL
	X	C163002-0201	5.00 X 5	MC CAULEY	90-100 lb-in	ALUMINUM
	X	1241156-12	5.00 X 5	CLEVELAND	90 lb-in	MAGNESIUM
	X	C163003-0201	5.00 X 5	MC CAULEY	90-100 lb-in	STEEL
	X	C163003-0401	5.00 X 5	MC CAULEY	*190-200 lb-in	STEEL

\*Capscrew

Figure 5-2A. Main and Nose Wheel Thru-Bolt Nut and Capscrew Torque Values

**CAUTION**

Be sure that spacers, wheel flanges and brake disc are seated on flange of wheel hub. Uneven or improper torque of capscrews can cause failure of capscrews or hub threads with resultant wheel failure.

- d. Tighten capscrews evenly and torque to the value specified in figure 5-2A.
- e. Place spacer and wheel flange on outboard side of wheel hub and align valve stem cutout in wheel flange.
- f. Place washer under head of each capscrew, insert capscrew thru wheel flange and spacer and start capscrews into wheel hub threads.

**CAUTION**

Be sure that spacers and wheel flanges are seated on flange of wheel hub. Uneven or improper torque of capscrews can cause failure of the capscrews, or hub threads with resultant wheel failure.

- g. Tighten capscrews evenly and torque to values specified in figure 5-2A.
- h. Clean and pack bearing cones with clean aircraft wheel bearing grease. (Refer to Section 2 for grease type.)

- i. Assemble bearing cones, grease seal felts and retainer into wheel hub.
- j. Inflate tire to seat tire beads, then adjust to correct tire pressure. Refer to figure 1-1 for correct tire pressure.

**5-15. MAIN WHEEL INSTALLATION.**

- a. Place wheel assembly on axle.
- b. Install axle nut and tighten axle nut until a slight bearing drag is obvious when the wheel is rotated. Back off nut to nearest castellation and install cotter pin.
- c. Place brake back plate in position and secure with bolts and washers.
- d. Install hub cap. Install speed fairing (if used) as outlined in paragraph 5-10.

**CAUTION**

Always check scraper-to-tire clearance after installing speed fairings, whenever a tire has been changed, and whenever scraper adjustment has been disturbed. If the aircraft is flown from surfaces with mud, snow, or ice, the fairing should be checked to make sure there is no accumulation which could prevent normal wheel rotation. Refer to paragraph 5-10 for correct scraper-to-tire clearance.

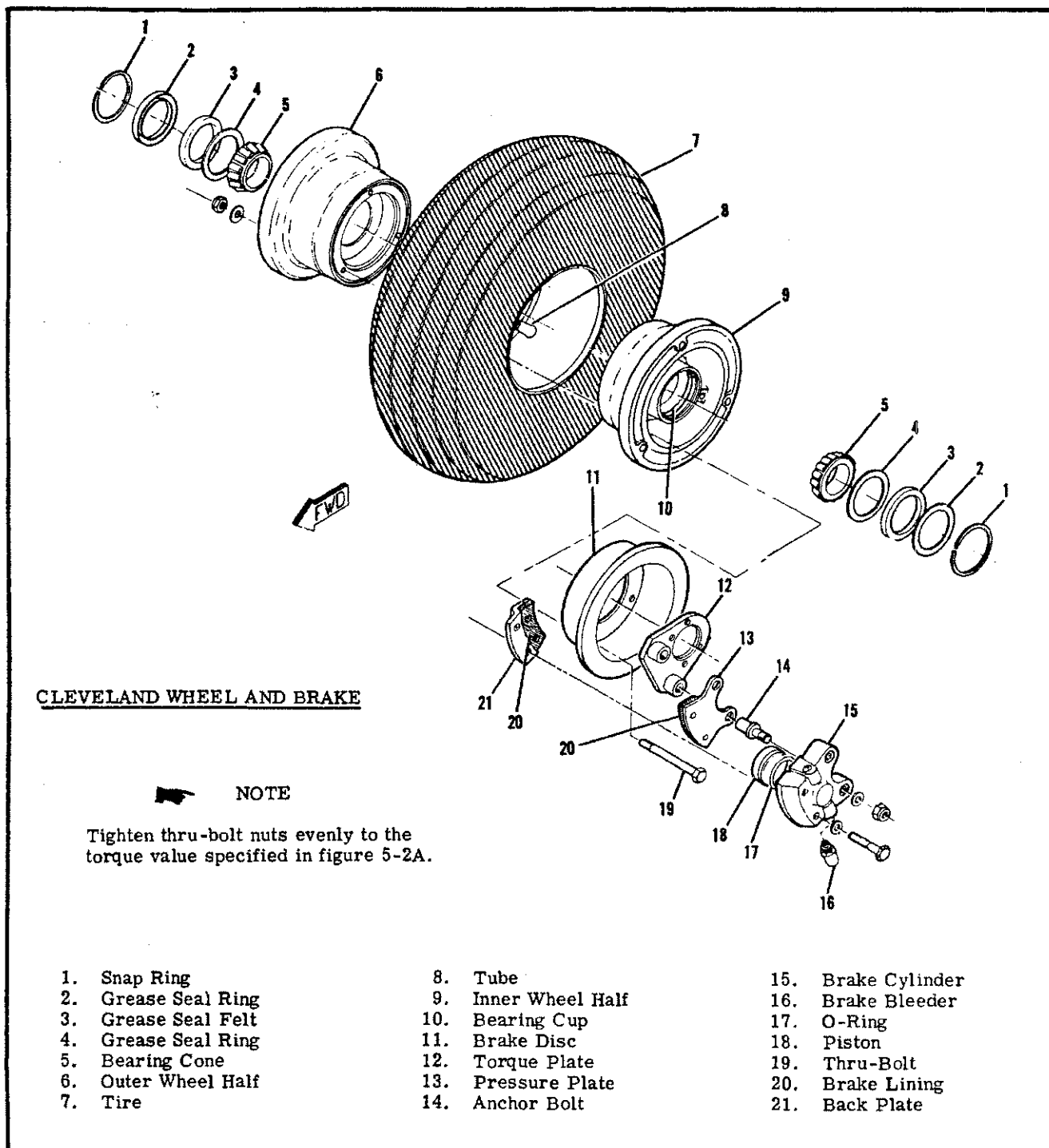

Figure 5-3. Main Wheel and Brake Assembly (Cleveland)

5-16. MAIN WHEEL AXLE REMOVAL. (FLAT GEAR.)

- a. Remove speed fairing, if installed, in accordance with paragraph 5-10.
- b. Remove wheel in accordance with paragraph 5-11.

- c. Disconnect, drain, and plug or cap the hydraulic brake line at the wheel brake cylinder.
- d. Remove four nuts, washers, and bolts securing axle, brake components, and speed fairing mounting plate (if used) to spring-strut.

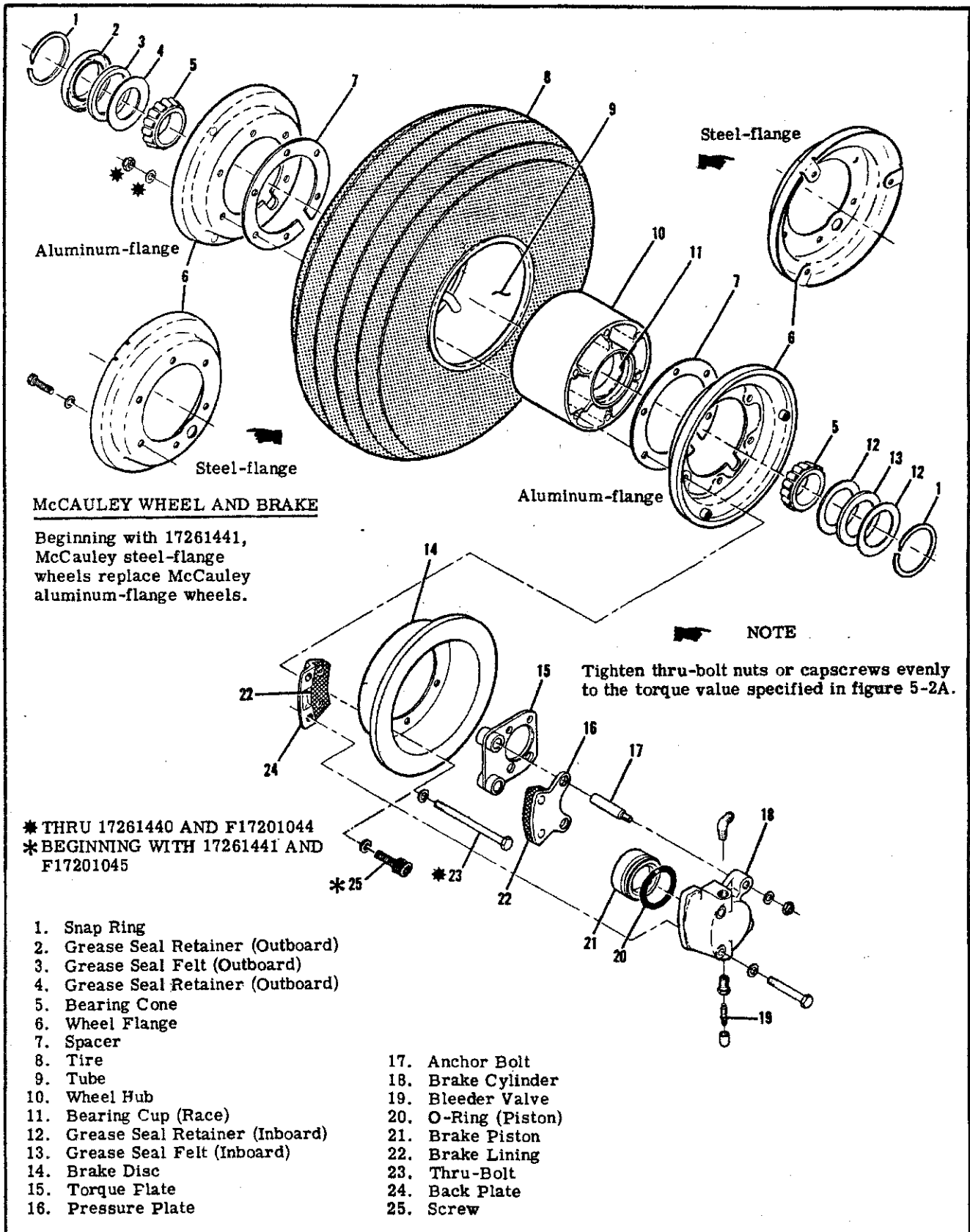

Figure 5-3A. Main Wheel and Brake Assembly (McCauley)



# SERVICE MANUAL CHANGE NOTICE

REFERENCE MANUAL NUMBER: D972-13 & D849-13

SMCN #77-1

DATE: Jan. 14, 1977

MANUAL TITLE: Skyhawk 1969 thru 1976 & Reims Rocket 1968 thru 1976

TO: ALL ZONES AND DEALERS

FROM: CUSTOMER SERVICES DEPARTMENT

CORRECT YOUR SERVICE MANUAL AS SHOWN BELOW.

SECTION NUMBER	PAGE NUMBER	PARAGRAPH NUMBER	DESCRIPTION OF CHANGES
5	5-11	5-18 & 5-19	(Manual D972-13 Skyhawk 1969 thru 1976)
5	5-12 & 5-13	5-18 & 5-19	(Manual D849-13 Reims Rocket 1968 thru 1976)  Some main gear axles on the above aircraft were bonded on at the factory. The attached procedure describes field removal and installation of the bonded on axles, and is to be retained as permanent information for use in conjunction with the above listed sections of these manuals.

Do not place tape in direct contact with tubular gear spring.

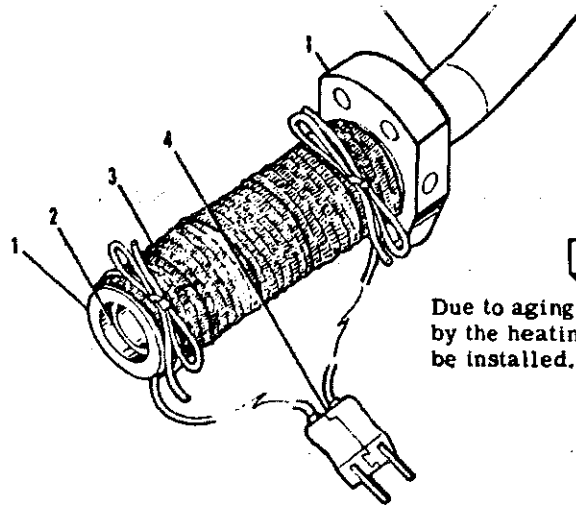

**WARNING**

Due to aging of the aluminum axle, caused by the heating tape, a new axle will have to be installed.

- 1. Axle
- 2. Tubular Gear Strut
- 3. Electrical Heating Tape
- 4. Plug

**Main Wheel Axle Removal**

**MAIN WHEEL AXLE REMOVAL.**

- a. Remove speed fairings, if installed, according to procedures outlined in applicable paragraph
- b. Remove wheels in accordance with procedures outlined in applicable paragraph of this section.
- c. Disconnect, drain and cap or plug hydraulic brake line at the wheel brake cylinder.
- d. Remove cotter pin, nut and bolt attaching axle to spring strut.
- e. Remove brake components and speed fairing plate from axle.

**NOTE**

Axles are bonded to the struts of tubular gear aircraft with EA9309-25GR adhesive, which is available from the Cessna Service Parts Center. The bond is too strong to allow the axle to be removed without first weakening the bond strength. The only methods of weakening the bond are with heat or cryogenic cold; heat being the most practical. A temperature of approximately 500°F is sufficient to weaken the bond so the axle can be removed. This is still a low enough temperature to prevent damage to the tubular strut.

- f. Remove axles as follows:

**NOTE**

Axles should be removed from strut, using electric heating tape, available from most scientific supply companies. One type can be obtained from Curtin Scientific Co., 6550 East 42nd St., P.O. Box 747, Tulsa, Oklahoma 74101. Tape should conform to the following: 192 watts, 24" long, 1" wide, flexible and heavily insulated.

- g. Wrap heating tape around axle from base head to outer end of axle and tie it on with string provided with the tape, as shown in the figure.

**CAUTION**

Do not place tape in direct contact with tubular gear spring.

- h. Plug electric tape into 110 volt wall socket and heat for 20 to 30 minutes.
- i. Unplug tape and remove from axle. Remove

axle by striking axle base head with a few sharp blows.

- j. Clean any old adhesive off landing gear spring with a wire brush. Brush strokes should run lengthwise along the spring. After old adhesive has been removed, wipe with clean rag saturated with acetone or alcohol. Immediately wipe dry with a clean, lint free cloth.

**WARNING**

Due to aging of the aluminum axle, caused by the heating tape, a new axle will have to be installed.

**MAIN WHEEL AXLE INSTALLATION.**

- a. Prior to installing new axle, wipe outer surface of tubular gear and inside of axle with solvent, drying immediately with a clean, lint free cloth.
- b. Mix EA9309-25GR adhesive, available from the Cessna Service Parts Center, in accordance with instructions in the package. Spread adhesive thinly and evenly on outer surface of landing gear spring in area that will be covered by axle.
- c. Place axle on gear spring and rotate axle to assure even coverage between inner surface of axle and outer surface of spring.
- d. Install retaining bolt, washers, nut and cotter pin. Tighten nut securely.
- e. Allow 24 hours at 75°F for adhesive to cure, or 30 minutes at 250°F, if heating equipment is available.
- f. Install brake components and speed fairing mounting plate to axle.
- g. Install wheel on axle in accordance with procedures outlined in applicable paragraph of this section.
- h. Connect hydraulic brake line to wheel brake cylinder.
- i. Fill and bleed hydraulic brake system in accordance with applicable paragraph in this section.
- j. Install speed fairings, if used, in accordance with applicable paragraph in this section.

#### NOTE

When removing axle from spring-strut, note number and position of the wheel alignment shims between axle and spring-strut. Mark these shims or tape them together carefully so that they can be installed in exactly the same position to ensure wheel alignment is not disturbed.

#### 5-17. MAIN WHEEL AXLE INSTALLATION. (FLAT GEAR.)

- a. Secure axle and brake components to spring-strut, making sure that wheel alignment shims and speed fairing mounting plate (if used) are installed in their original position.
- b. Install wheel assembly on axle in accordance with paragraph 5-15.
- c. Connect hydraulic brake line to wheel brake cylinder.
- d. Fill and bleed affected brake system in accordance with paragraph 5-54.
- e. Install speed fairing (if used) in accordance with paragraph 5-10.

#### 5-18. MAIN WHEEL AXLE REMOVAL. (TUBULAR.)

- a. Remove speed fairing, if installed, in accordance with paragraph 5-10.
- b. Remove wheel in accordance with paragraph 5-11.
- c. Disconnect, drain, and cap or plug hydraulic brake line at the wheel brake cylinder.
- d. Remove four bolts attaching brake torque plate and speed fairing mounting plate to axle.
- e. Remove cotter pin, nut, washer, and bolt attaching axle to tubular strut.
- f. Remove axle from spring-strut.

#### 5-19. MAIN WHEEL AXLE INSTALLATION. (TUBULAR.)

- a. Install axle on spring strut, using wet primer on faying surfaces of axle and spring-strut. Axle is installed with tapered edges to bottom.
- b. Install bolt, washer, and nut attaching axle to spring-strut. After tightening nut, install cotter pin.
- c. Install brake components and speed fairing mounting plate to axle.
- d. Install wheel on axle in accordance with paragraph 5-15.
- e. Connect hydraulic brake line to wheel brake cylinder.
- f. Fill and bleed hydraulic brake system in accordance with paragraph 5-54.
- g. Install speed fairing, if used, in accordance with paragraph 5-10.

5-20. Deleted.

5-21. Deleted.

#### 5-22. MAIN WHEEL ALIGNMENT (FLAT GEAR).

Correct main wheel alignment, for the flat gear, is obtained through the use of tapered shims between the flange of the axle and spring-strut. See figure 5-4 for procedure to use when main wheel alignment is required. Wheel shims and the correction imposed on the wheel by the various shims and their location are listed in the illustration.

#### NOTE

Failure to obtain acceptable wheel alignment through the use of the shims indicate a deformed main gear spring-strut or strut attaching bulkhead out of alignment.

#### 5-22A. MAIN WHEEL ALIGNMENT (TUBULAR). (Refer to figure 1-1.)

5-23. WHEEL BALANCING. Since uneven tire wear is usually the cause of wheel unbalance, replacing the tire probably will correct this condition. Tire and tube manufacturing tolerances permit a specified amount of static unbalance. The light-weight point of the tire is marked with a red dot on the tire sidewall and the heavy-weight point of the tube is marked with a contrasting color line (usually near the inflation valve stem). When installing a new tire and/or tube, place these marks adjacent to each other. If a wheel shows evidence of unbalance during service, it may be statically balanced. Wheel balancing equipment is available from the Cessna Service Parts Center.

5-24. NOSE GEAR. The steerable nose wheel mounted on an air-oil shock strut comprises the nose gear. The shock strut is secured to forgings riveted and/or bolted to the firewall and lower fuselage structure. Nose wheel steering is afforded by two spring-loaded push-pull rods from the rudder pedal bars. A hydraulic fluid-filled shimmy dampener is provided to minimize nose wheel shimmy. Some models of the 172 Series are equipped with speed fairings and on some models the speed fairing is optional equipment. The various configurations of these nose wheel speed fairings are illustrated in figure 5-5. Disassembly, inspection and repair, and reassembly of the various nose wheel configurations are described in separate paragraphs for each configuration. The solid wheels having two wheel halves are manufactured by Cleveland Aircraft Products Co. and webbed wheels having two flanges and a hub are manufactured by McCauley Industrial Corporation. The Cleveland wheels are shown in figure 5-7. The McCauley wheels have either aluminum flanges or steel flanges as shown in figure 5-8. The aluminum flanges are attached to the wheel hub by thru-bolts and nuts as shown in figure 5-8. The steel flanges are attached to the wheel hub by either thru-bolts or capscrews as shown in figure 5-8. During assembly of the nose wheel, the thru-bolt nuts or capscrews, as applicable, shall be tightened evenly and torqued to the value specified in figure 5-2A.

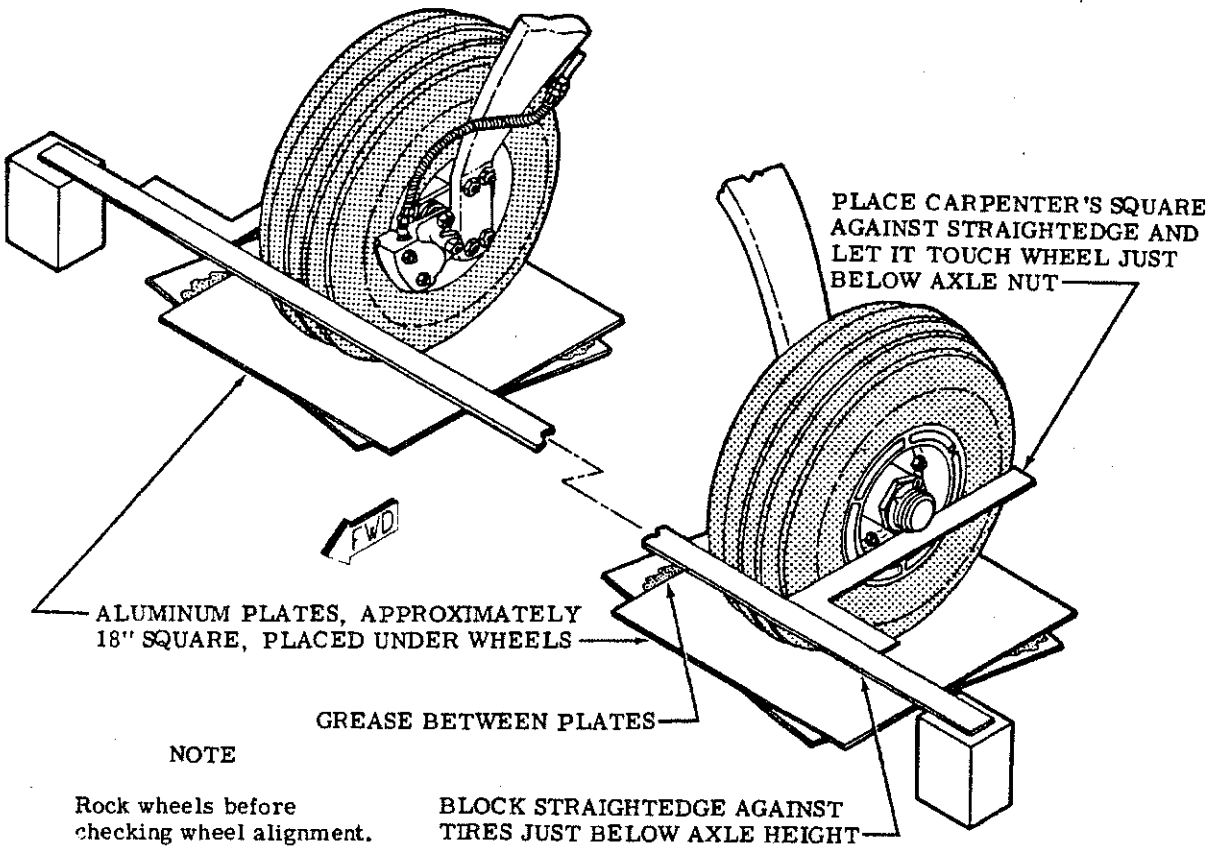

#### TOP VIEW OF TOE-IN CHECK

Measure toe-in at edges of wheel flange. Difference in measurements is toe-in for one wheel. (half of total toe-in.)

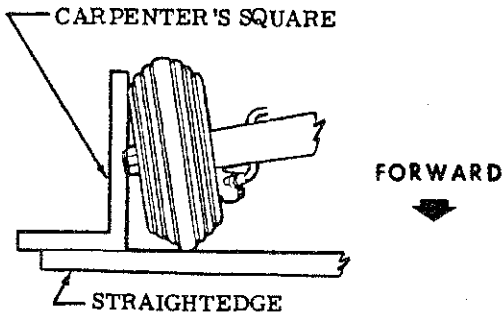

#### FRONT VIEW OF CAMBER CHECK

Measure camber by reading protractor level held vertically against outboard flanges of wheel.

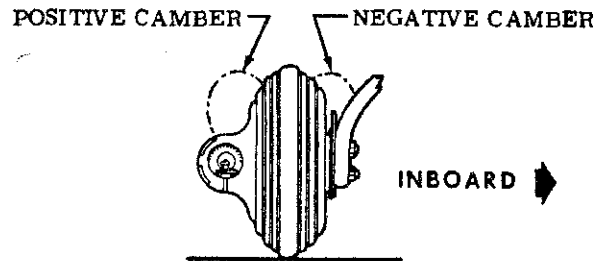

#### NOTE

Setting toe-in and camber within these tolerances while the cabin and fuel tanks are empty will give approximately zero toe-in and zero camber at gross weight. Therefore, if normal operation is at less than gross weight and abnormal tire wear occurs, realign the wheels to attain the ideal setting for the load conditions. Refer to sheet 2 of this figure for shims availability and their usage. Always use the least number of shims possible to obtain the desired result.

Figure 5-4. Main Wheel Alignment (Sheet 1 of 2)





5-25. TROUBLE SHOOTING.

TROUBLE	PROBABLE CAUSE	REMEDY
NOSE WHEEL SHIMMY.	Nose strut loose in attaching clamps.	Tighten nose strut attaching bolts.
	Shimmy dampener lacks fluid.	Refer to paragraph 2-24.
	Defective shimmy dampener.	Repair or replace defective shimmy dampener.
	Loose or worn nose wheel steering linkage.	Tighten or replace defective linkage.
	Nose wheel out of balance.	Correct in accordance with paragraph 5-32.
	Loose or defective nose wheel bearings.	Tighten wheel bearings properly; replace, if defective.
	Loose torque links.	Add washers or replace as necessary.
NOSE STRUT WILL NOT HOLD AIR PRESSURE.	Defective air filler valve, or valve not tight.	Check gasket and tighten loose valve. Replace, if defective.
	Defective strut seals.	Replace defective seals.
HYDRAULIC FLUID LEAKAGE FROM NOSE STRUT.	Defective strut seals.	Replace defective seals.

5-26. NOSE GEAR REMOVAL AND INSTALLATION.  
(See figure 5-6.)

- a. Remove engine cowling for access.
- b. Weight or tie-down the aircraft tail to raise nose wheel off floor.
- c. Disconnect nose wheel steering tubes from nose gear steering collar.
- d. Deflate strut completely and telescope strut to its shortest length.

**WARNING**

Be sure strut is deflated completely before removing bolt at top of strut or disconnecting the torque links.

- e. Remove bolt at top of strut and remove bolts, and nuts which clamp strut to lower forging on fire-wall.
- f. Pull the strut assembly down and out of upper attach forging.
- g. To install the nose gear assembly, reverse the preceding steps. Always install bolt at top forging before clamping strut in lower forging to prevent misalignment. Tighten clamp bolts in lower forging to 120±20 lb-in.

NOTE

Observe CAUTION in figure 5-6 when installing nose gear strut.

5-27. NOSE WHEEL SPEED FAIRING REMOVAL AND INSTALLATION.

- a. Weight or tie-down tail of aircraft to raise nose wheel off the floor.
- b. Remove nose wheel axle stud.

**WARNING**

The cover plate is secured by the lower torque link attaching bolt. Deflate strut before removing this bolt.

- c. Deflate strut and remove bolt securing cover plate to strut. Remove cover plate.
- d. Remove bolt securing speed fairing and tow-bar spacers to strut.
- e. Slide speed fairing up and remove nose wheel. Loosen scraper as necessary.
- f. Rotate speed fairing 90 degrees and work it down over the nose wheel fork to remove.
- g. Install speed fairing by reversing the preceding steps. Tighten axle stud until a slight bearing drag is obvious when the wheel is rotated. Back off the nut to the nearest castellation and install cotter pins.
- h. Service shock strut after installation has been completed.

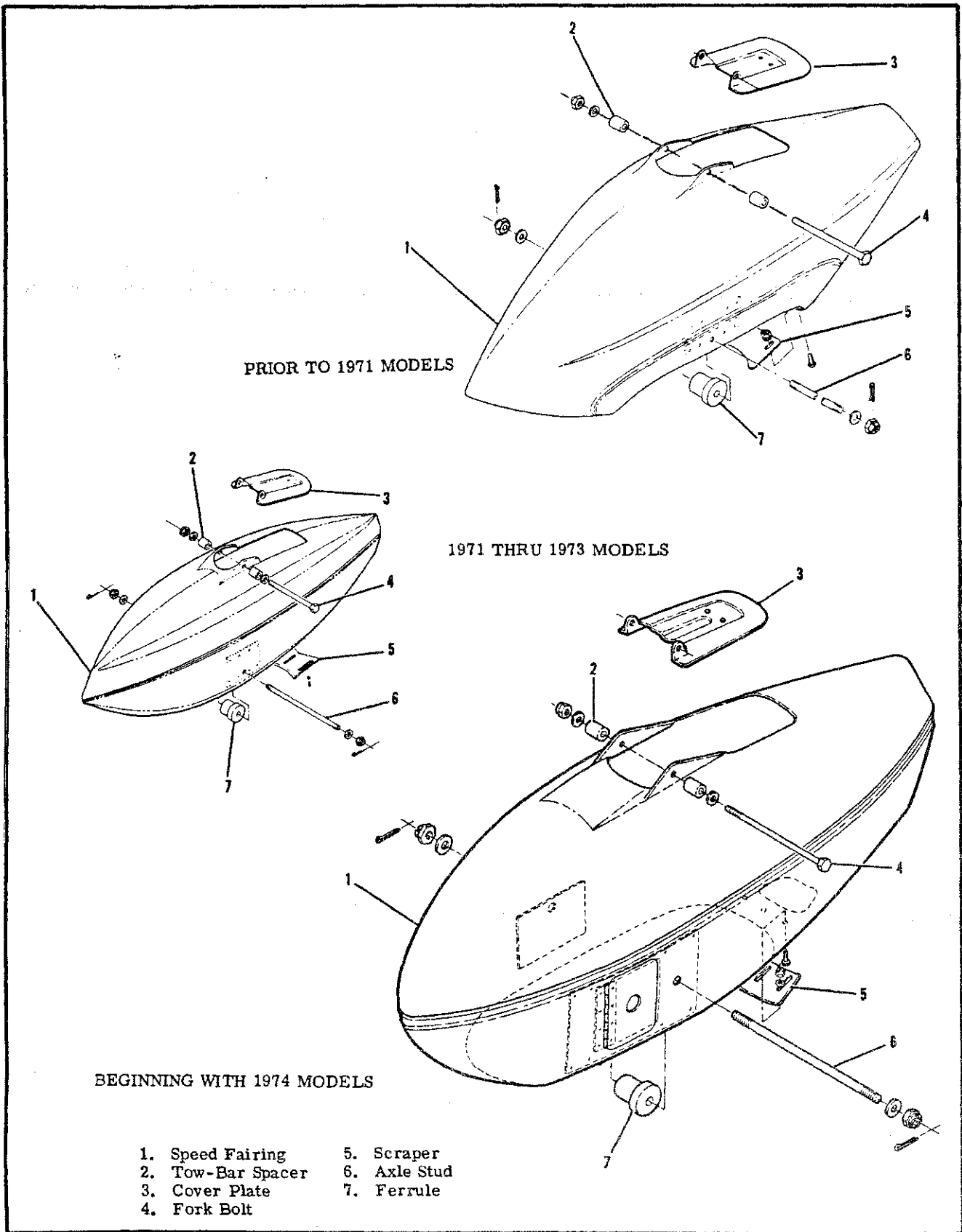

Figure 5-5. Nose Wheel Speed Fairing

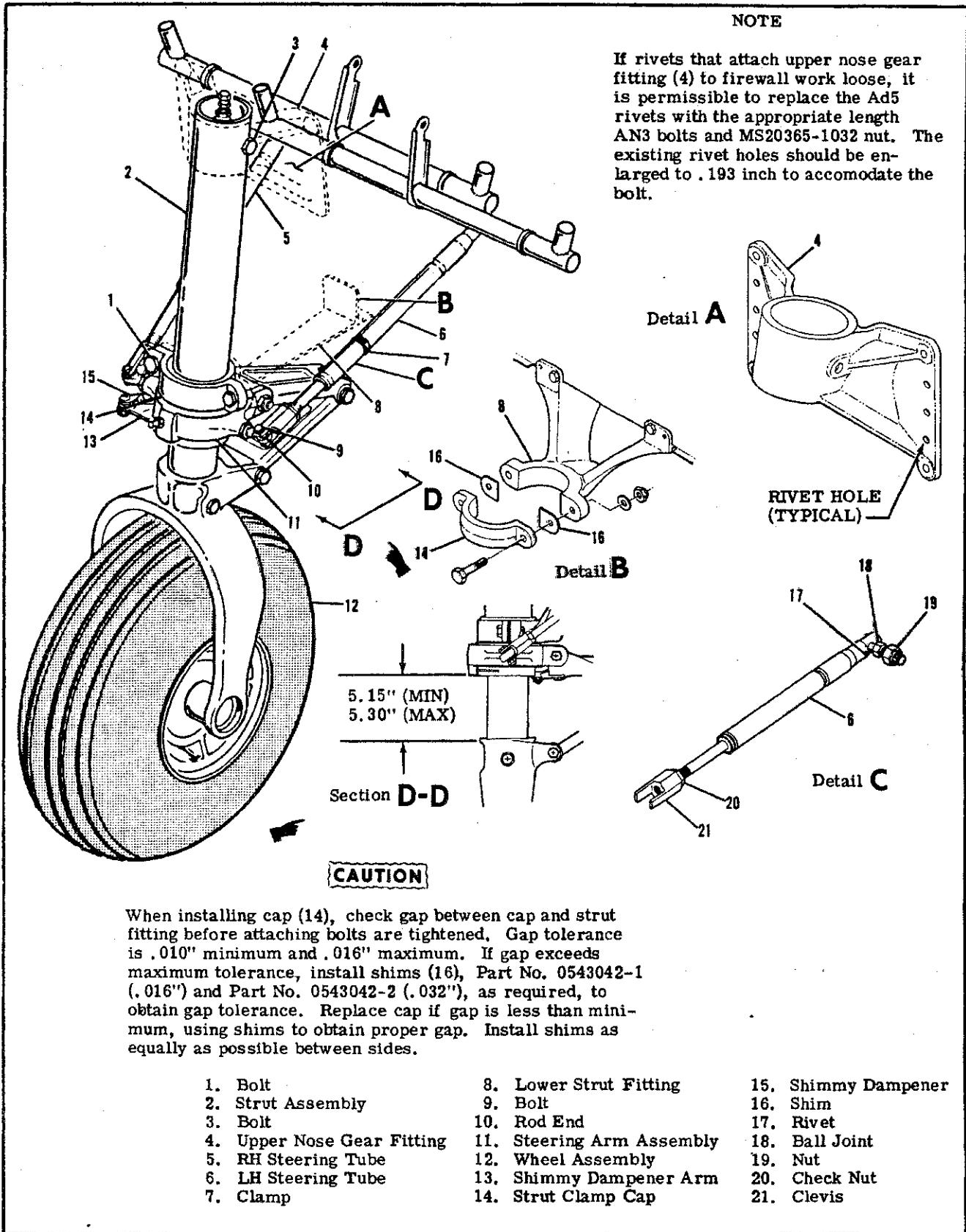

Figure 5-6. Nose Gear Installation

**CAUTION**

Always check scraper clearance after installing speed fairing, whenever a tire has been changed, and whenever scraper adjustment has been disturbed. Set clearance between tire and scraper for 0.38 inch. Elongated holes in the scraper are provided for adjustment. If the aircraft is flown from surfaces with mud, snow, or ice, the speed fairings should be checked to make sure there is no accumulation which could prevent normal wheel rotation. Wipe fuel and oil from speed fairing to prevent stains and deterioration.

**5-28. NOSE WHEEL REMOVAL AND INSTALLATION.**

- a. Weight or tie-down tail of aircraft to raise nose wheel off the floor.
- b. Remove nose wheel axle bolt.
- c. Use a rod or long punch inserted through one axle bolt bucket or ferrule to tap the opposite one out of the fork. Remove both buckets or ferrules and pull nose wheel from fork. Loosen scraper if necessary.

**NOTE**

Buckets are used on aircraft without speed fairings. Solid ferrules are used on aircraft with speed fairings.

- d. Remove spacers and axle tube before disassembling the nose wheel.
- e. Reverse the preceding steps to install the nose wheel. Tighten axle bolt until a slight bearing drag is obvious when the wheel is rotated. Back off the nut to the nearest castellation and install cotter pin.

**CAUTION**

On aircraft equipped with speed fairings, always check scraper-to-tire clearance after installing speed fairing, whenever a tire has been changed, or whenever scraper adjustment has been disturbed. Set scraper clearance in accordance with paragraph 5-27.

**5-29. NOSE WHEEL DISASSEMBLY. (Cleveland).**

- a. Remove hub caps and valve core, completely deflate tire and break tire beads loose from wheel rims.

**WARNING**

Injury can result from attempting to separate wheel halves with the tire inflated. Avoid damaging wheel flanges when breaking tire beads loose. A scratch, gouge, or nick in the wheel may cause wheel failure.

- b. Remove thru-bolts and separate wheel halves.
- c. Remove tire and tube from wheel halves.

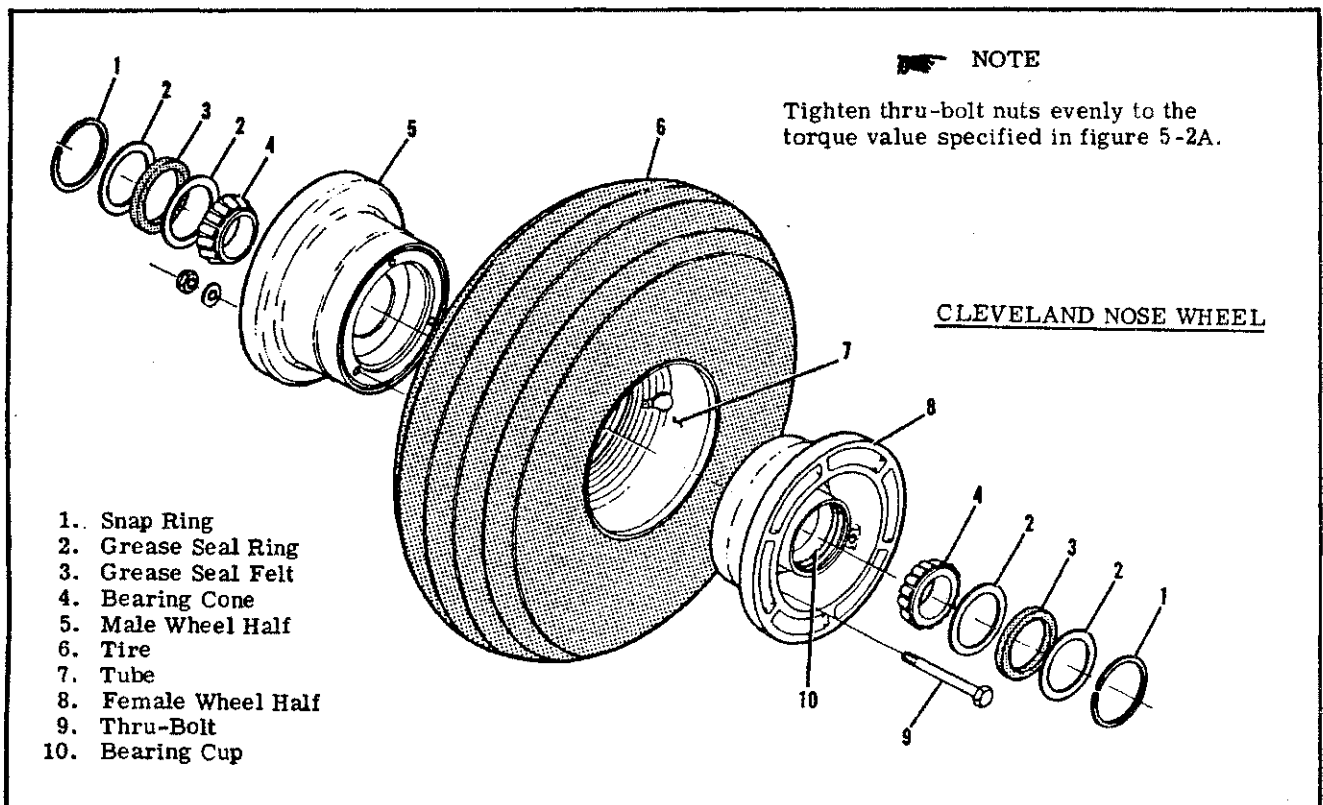

Figure 5-7. Nose Wheel (Cleveland)

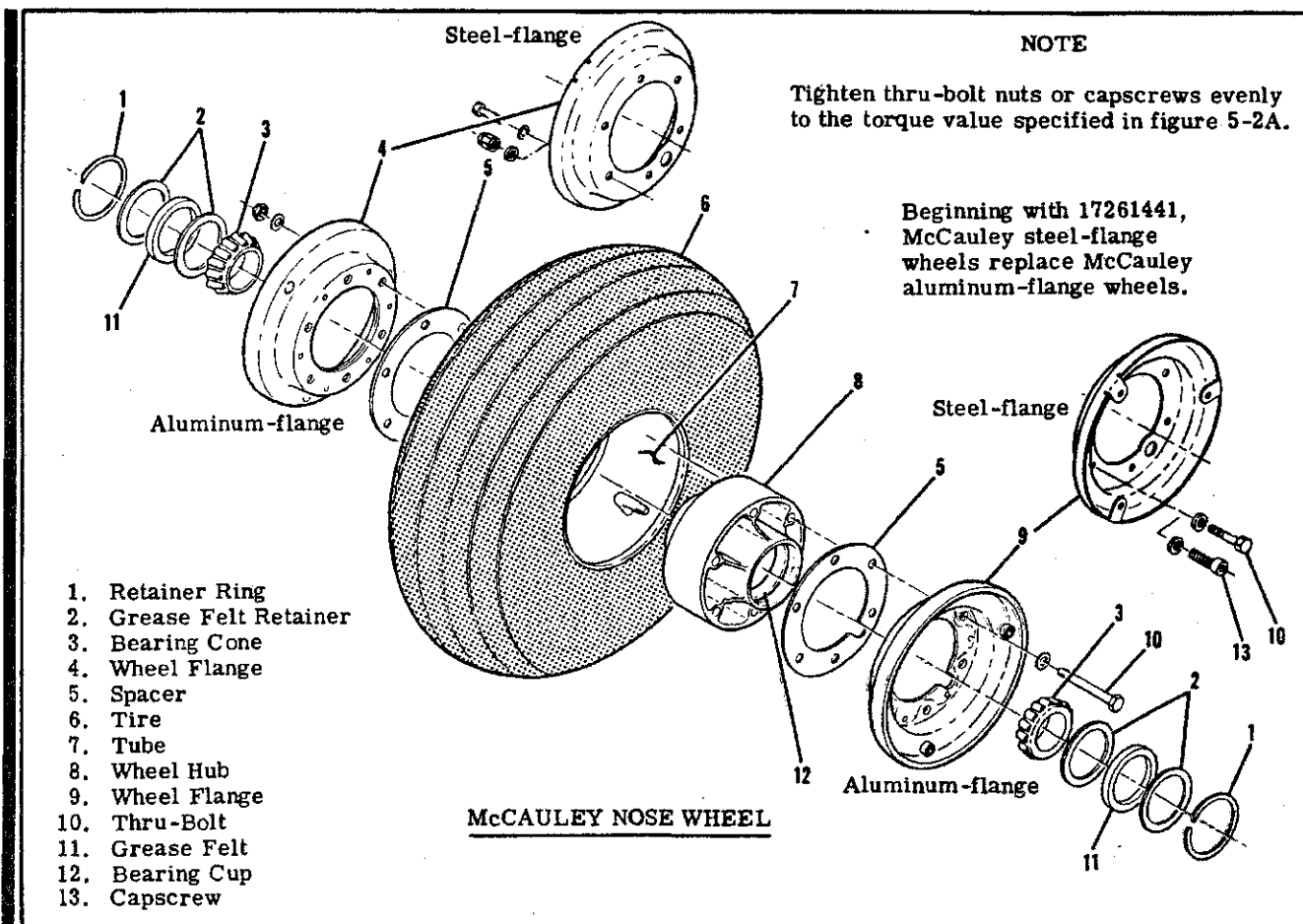

Figure 5-8. Nose Wheel (McCauley)

d. Remove bearing retainer rings, grease seal rings, felts and bearing cones.

**NOTE**

The bearing cups (races) are a press-fit in the wheel halves and should not be removed unless a new part is to be installed. To remove the bearing cups, heat wheel half in boiling water for 30 minutes, or in an oven not to exceed 149°C (300°F). Using an arbor press, if available, press out the bearing cup and press in the new cup while the wheel is still hot.

**5-30. NOSE WHEEL INSPECTION AND REPAIR (Cleveland Wheel).**

- a. Clean all metal parts and grease seal felts in solvent and dry thoroughly.
- b. Inspect wheel halves for cracks. Cracked wheel halves shall be discarded and new parts used. Sand out nicks, gouges, and corroded areas. When protective coating has been removed, the area should be cleaned thoroughly, primed with zinc chromate and painted with aluminum lacquer.
- c. Carefully inspect bearing cones and cups for damage and discoloration. After cleaning, pack

bearing cones with clean aircraft wheel bearing grease (Section 2) before installing in wheel half.

**5-31. NOSE WHEEL REASSEMBLY (Cleveland Wheel).**

- a. Insert tube in tire, aligning index marks on tire and tube.
- b. Place tire and tube on wheel half and position valve stem through hole in wheel half.
- c. Insert thru-bolts, position other wheel half, and secure with nuts and washers. Take care to avoid pinching tube between wheel halves. Tighten thru-bolt nuts to the torque values stipulated in figure 5-2A.

**CAUTION**

Uneven or improper torque on the thru-bolt nuts may cause bolt failure with resultant wheel failure.

- d. Clean and pack bearing cones with clean aircraft wheel bearing grease (Section 2).
- e. Assemble bearing cones, seals, and retainers into the wheel halves.
- f. Inflate tire to seat tire beads, then adjust to correct pressure (figure 1-1).

**5-31A. NOSE WHEEL DISASSEMBLY (McCauley Wheel with Thru-bolts).**

- a. Remove hub caps, completely deflate tire, and break tire beads loose at wheel flanges.

**WARNING**

Injury can result from attempting to remove wheel flanges with tire and tube inflated. Avoid damaging wheel flanges when breaking tire beads loose. A scratch, gouge or nick in wheel flange may cause wheel failure.

- b. Remove thru-bolt nuts and washers.
- c. Remove thru-bolts and separate wheel flanges from wheel hub. Retain spacers between wheel flanges and wheel hub.
- d. Remove wheel hub from tire and tube.
- e. Remove retainer rings and remove grease seal retainers, grease seal felts, and bearing cones from wheel hub.

**NOTE**

The bearing cups (races) are a press fit in the wheel hub and should not be removed unless a new part is to be installed. To remove the bearing cup, heat wheel hub in boiling water for 30 minutes, or in an oven not to exceed 121°C (250°F). Using an arbor press, if available, press out the bearing cup and press in the new bearing cup while the wheel hub is still hot.

**5-31B. NOSE WHEEL INSPECTION AND REPAIR (McCauley Wheel with Thru-bolts).**

- a. Clean all metal parts, grease seal felts, and mylar spacers in cleaning solvent and dry thoroughly.
- b. Inspect wheel flanges, and wheel hub for cracks. Cracked wheel flanges or hub shall be discarded and new parts installed. Sand out smooth nicks, gouges, and corroded areas. When the protective coating has been removed, the area should be cleaned thoroughly, primed with zinc chromate and painted with aluminum lacquer.
- c. Carefully inspect bearing cones and cups for damage and discoloration. After cleaning, pack bearing cones with clean aircraft wheel bearing grease (Section 2) before installing in wheel hub.

**5-31C. NOSE WHEEL REASSEMBLY (McCauley Wheel with Thru-bolts).**

- a. Insert tube in tire, aligning index marks on tire and tube.
- b. Place wheel hub in tire with valve stem in cutout of wheel hub.
- c. Place spacer and wheel flange on one side of wheel hub and with washer under head of thru-bolt insert bolt through wheel flange and wheel hub.
- d. Place spacer and wheel flange on other side and align valve stem in cutout in wheel flange.
- e. Install washers and nuts on thru-bolts.

**CAUTION**

Be sure that spacers and wheel flanges are seated on flange of wheel hub. Uneven or improper torque of the thru-bolt nuts can cause failure of the bolts, with resultant wheel failure.

- f. Tighten thru-bolt nuts evenly and torque to the values stipulated in figure 5-2A.
- g. Clean and pack bearing cones with clean aircraft wheel bearing grease (Section 2).
- h. Assemble bearing cones, grease seal felts and retainers into wheel hub.
- i. Inflate tire to seat tire beads, then adjust to correct tire pressure. See figure 1-1 for correct tire pressure.

**5-31D. NOSE WHEEL DISASSEMBLY (McCauley Wheel with Capscrews).**

- a. Remove hub caps, completely deflate tire and break tire beads loose at wheel flanges.

**WARNING**

Injury can result from attempting to remove wheel flanges with tire and tube inflated. Avoid damaging wheel flanges when breaking tire beads loose. A scratch, gouge or nick in wheel flange could cause wheel failure.

- b. Remove capscrews and washers.
- c. Separate wheel flanges from wheel hub. Retain spacers on each side of wheel hub.
- d. Remove wheel hub from tire.
- e. Remove retainer rings and remove grease seal retainers, grease seal felts and bearing cones.

**NOTE**

The bearing cups (races) are a press-fit in the wheel hub and should not be removed unless a new part is to be installed. To remove the bearing cup, heat wheel hub in boiling water for 30 minutes, or in an oven not to exceed 121°C (250°F). Using an arbor press, if available, press in the new bearing cup while the wheel hub is still hot.

**5-31E. NOSE WHEEL INSPECTION AND REPAIR (McCauley Wheel with Capscrews).**  
Refer to paragraph 5-31B.

**5-31F. NOSE WHEEL REASSEMBLY (McCauley Wheel with Capscrews).**

- a. Insert tube in tire, aligning index marks on tire and tube.
- b. Place wheel hub in tire with valve stem in cutout of wheel hub.
- c. Place spacer and wheel flange on one side of wheel hub.
- d. Place washer under head of each capscrew, insert capscrew thru wheel flange and spacer and start capscrews into wheel hub threads.





### CAUTION

Be sure that spacers and wheel flanges are seated on flange of wheel hub. Uneven or improper torque of capscrews can cause failure of the capscrews or hub threads with resultant wheel failure.

e. Tighten capscrews evenly and torque to the value specified in figure 5-2A.

f. Place spacer and wheel flange on other side of wheel hub and align valve stem in cutout in wheel flange.

g. Place washer under head of each capscrew, insert capscrew thru wheel flange and spacer and start capscrews into wheel hub threads.

### CAUTION

Be sure that spacers and wheel flanges are seated on flange of wheel hub. Uneven or improper torque of capscrews can cause failure of the capscrews or hub threads with resultant wheel failure.

h. Tighten capscrews evenly and torque to the value specified in figure 5-2A.

i. Clean and pack bearing cones with clean aircraft wheel bearing grease. (Refer to Section 2 for grease type.)

j. Assemble bearing cones, grease seal felts and retainer into wheel hub.

k. Inflate tire to seat tire beads, then adjust to correct tire pressure (refer to Section 1).

5-32. WHEEL BALANCING. Refer to paragraph 5-23 for wheel balancing.

5-33. NOSE GEAR SHOCK STRUT DISASSEMBLY. The nose gear shock strut is shown in figure 5-9. Removal and installation is outlined in paragraph 5-26. The heavy-duty nose gear is shown in figure 5-10 which may be used as a guide during maintenance. Removal, installation, and disassembly procedures are the same as those for the standard nose gear strut except for the differences shown in figure 5-10. The following procedures apply to the nose gear shock strut after it has been removed from the aircraft, and the speed fairing and nose wheel have been removed. In many cases, separation of the upper and lower strut will permit inspection and parts installation without removal or complete disassembly of the strut.

### WARNING

Be sure strut is completely deflated before

removing lock ring in lower end of upper strut, or disconnecting the torque links.

a. Remove shimmy dampener.

b. Remove torque links. Note position of washers, shims, and spacers.

c. Remove lock ring from groove inside lower end of upper strut. A small hole is provided in the lock ring groove to facilitate removal of the lock ring.

### NOTE

Hydraulic fluid will drain from strut as lower strut is pulled from upper strut.

d. Use a straight, sharp pull to separate upper and lower struts. Invert strut and drain remaining hydraulic fluid.

e. Remove lock ring and bearing at top of lower strut.

f. Slide packing support ring, scraper ring, retaining ring, and lock ring from lower strut, noting relative position and top side of each ring; wire together if desired.

g. Remove O-ring and back-up rings from packing support ring.

h. Remove bolt securing fork and lower strut and remove bushing from fork and strut.

i. Push metering pin and base plug assembly from lower strut. Remove O-rings and metering pin from base plug.

### NOTE

Lower strut barrel and fork are a press fit, drilled on assembly. Separation of these parts is not recommended, except for installation of new parts.

j. Remove retaining ring securing steering arm assembly on upper strut and remove steering arm assembly, shims, and washer.

k. Push orifice support from upper strut and remove O-ring.

l. Remove filler valve assembly from orifice support.

5-34. NOSE GEAR SHOCK STRUT REASSEMBLY. (See figure 5-9.)

a. Thoroughly clean all parts in cleaning solvent and inspect them carefully. Replace all worn or defective parts and all O-rings and back-up rings with new parts.

b. Assemble the shock strut by reversing the order

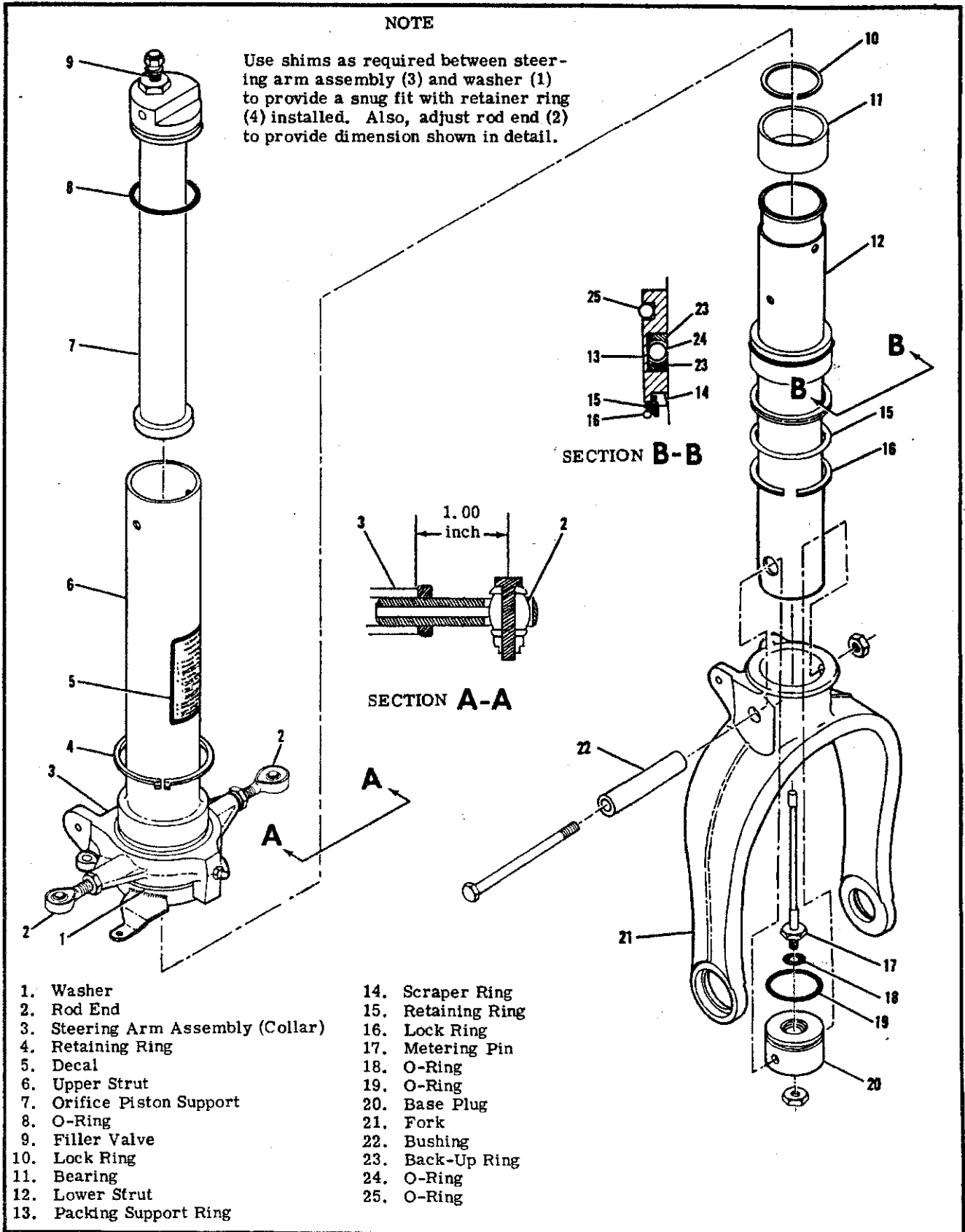

Figure 5-9. Nose Gear Shock Strut

of the procedure outlined in paragraph 5-33 with the exception that special attention must be paid to the following procedures.

c. Sharp metal edges should be smoothed with No. 400 emery paper, then thoroughly cleaned with solvent.

d. Used sparingly, Dow Corning DC-4 compound is recommended for O-ring lubrication. All other internal parts should be liberally coated with hydraulic fluid during assembly.

**NOTE**

Cleanliness and proper lubrication, along with careful workmanship are important during assembly of the shock strut.

e. When installing steering arm assembly, lubricate needle bearing in collar with general purpose grease (figure 2-5) before installing. If needle bearing is defective, install new steering arm assembly. Use shims as required between steering arm assembly and washer to provide a no play fit with retainer ring installed. Shims are available from the Cessna Service Parts Center as follows:

1243030-5 . . . . .	0.006 inch
1243030-6 . . . . .	0.012 inch
1243030-7 . . . . .	0.020 inch

f. When installing lock ring in lower end of upper strut groove, position lock ring so that one of its ends covers the small access hole in the lock ring groove at the bottom of the upper strut.

g. Temporary bolts or pins of correct diameter and length are useful tools for holding parts in correct relation to each other during assembly and installation.

h. After re-assembling the strut, install in accordance with paragraph 5-26.

i. After installation, service shock strut as outlined in Section 2.

5-35. **TORQUE LINKS.** The torque links are illustrated in figure 5-12, which may be used as a guide for removal, disassembly, assembly, and installation. The torque links keep the lower strut aligned with the nose gear steering system but permit shock strut action. Torque link bushings should not be removed except for replacement with new parts. Excessively worn parts should be replaced with new parts. Always deflate nose gear strut before disconnecting torque links.

5-36. **SHIMMY DAMPENER.** The shimmy dampener

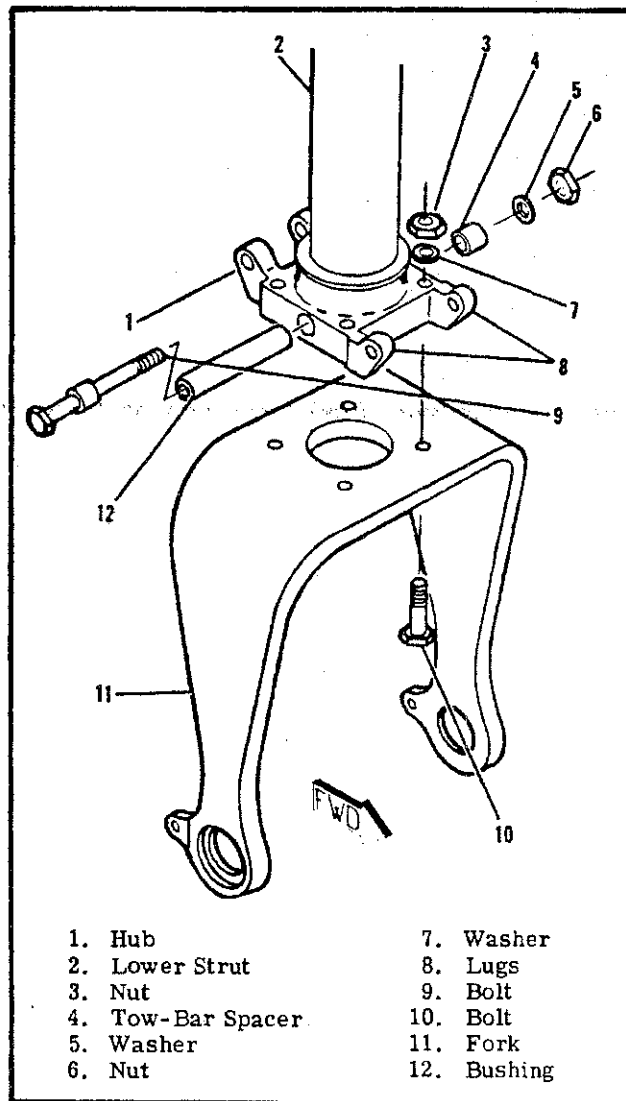

- |                   |             |
|-------------------|-------------|
| 1. Hub            | 7. Washer   |
| 2. Lower Strut    | 8. Lugs     |
| 3. Nut            | 9. Bolt     |
| 4. Tow-Bar Spacer | 10. Bolt    |
| 5. Washer         | 11. Fork    |
| 6. Nut            | 12. Bushing |

Figure 5-10. Heavy-Duty Shock Strut

er provided for the nose gear offers resistance to shimmy by forcing hydraulic fluid through small orifices in a piston. The dampener piston shaft is secured to a stationary part and the housing is secured to the nose wheel steering arm assembly which moves as the nose wheel is turned, causing relative motion between the dampener shaft and housing. The shimmy dampener is shown in figure 5-11, which may be used as a guide for removal, disassembly, re-assembly, and installation. When assembling

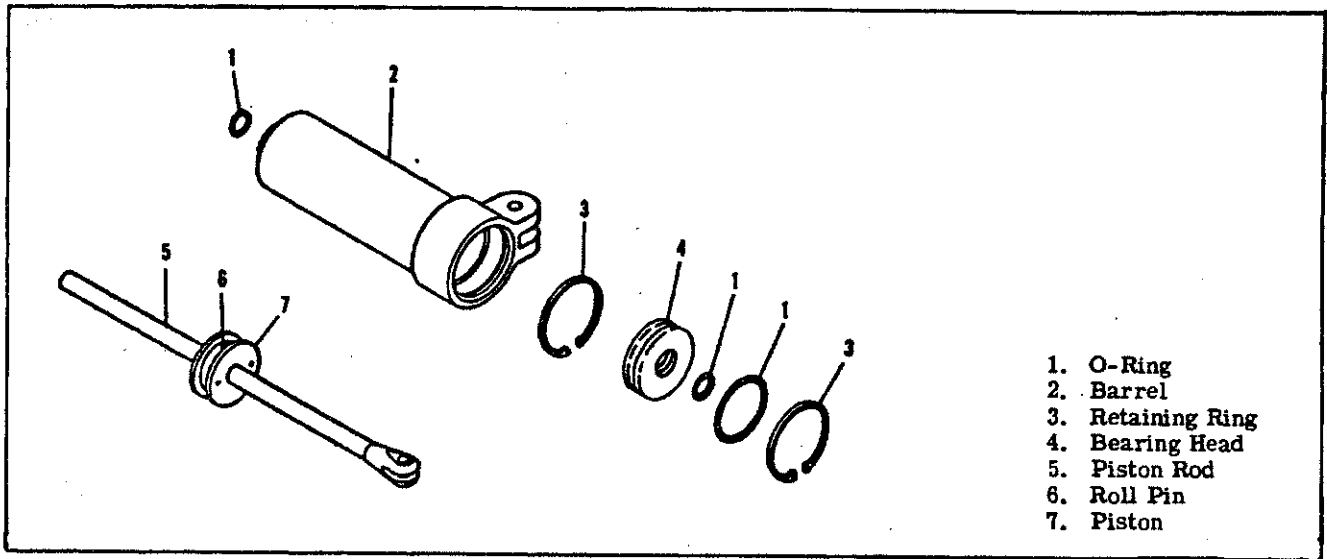

Figure 5-11. Nose Gear Shimmy Dampener

shimmy dampener, use new O-rings. Lubricate parts during assembly with clean hydraulic fluid. Refer to Section 2 for shimmy dampener servicing procedures.

5-37. NOSE WHEEL STEERING SYSTEM. Nose wheel steering is accomplished through the use of the rudder pedals. Spring-loaded steering rod assemblies connect the nose gear steering arm assembly to arm on the rudder bars. Steering is afforded up to approximately 10 degrees each side of neutral, after which brakes may be used to gain a maximum deflection of 30 degrees right or left of center. A flexible boot seals the fuselage entrance of the steering rod assembly.

5-38. STEERING ROD ASSEMBLY. The steering rod assembly is spring-loaded and should not be disassembled internally. The steering rods are connected by a clevis to the rod ends extending from the nose gear steering arm assembly and to arms on the rudder crossbars.

5-39. NOSE WHEEL STEERING ADJUSTMENT. Since the nose wheel steering and rudder systems are interconnected, adjustment to one system may affect the other system. Section 10 contains rigging instructions for the nose wheel steering system as well as the rudder system.

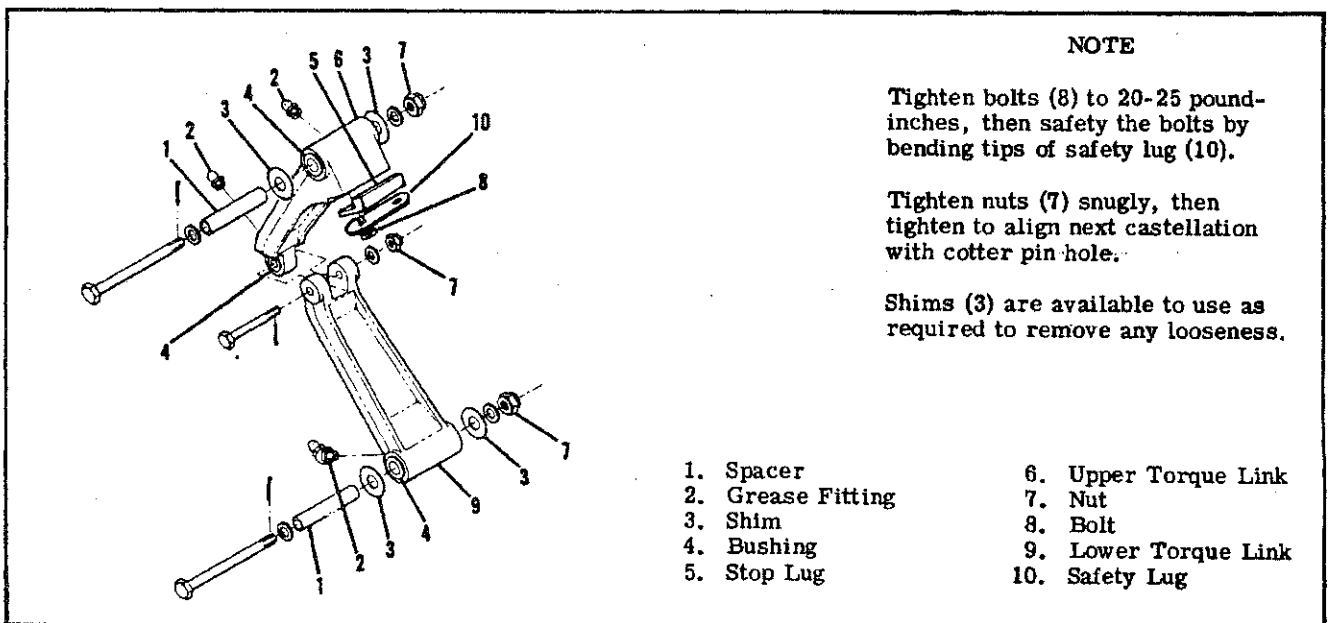

Figure 5-12. Nose Gear Torque Links

5-40. BRAKE SYSTEM.

5-41. GENERAL DESCRIPTION. The hydraulic brake system consists of two brake master cylinders, located just forward of the pilot rudder pedals, brake

lines and hose connecting each brake master brake cylinder to its wheel brake cylinder, the single-disc, floating-cylinder type brake assembly, located at each main landing gear wheel.

5-42. TROUBLE SHOOTING.

TROUBLE	PROBABLE CAUSE	REMEDY
DRAGGING BRAKES.	Brake pedal binding.	Check and adjust properly.
	Parking brake linkage holding brake pedal down.	Check and adjust properly.
	Worn or broken piston return spring. (In master cylinder.)	Repair or replace master cylinder.
	Insufficient clearance at Lock-O-Seal in master cylinder.	Adjust as shown in figure 5-13.
	Restriction in hydraulic lines or restriction in compensating port in master brake cylinders.	Drain brake lines and clear the inside of the brake line with filtered compressed air. Fill and bleed brakes. If cleaning the lines fails to give satisfactory results, the master cylinder may be faulty and should be repaired
	Worn, scored or warped brake discs.	Replace brake discs and linings.
	Damage or accumulated dirt restricting free movement of wheel brake parts.	Clean and repair or replace parts as necessary.
BRAKES FAIL TO OPERATE.	Leak in system.	If brake master cylinders or wheel brake assemblies are leaking, they should be repaired or replaced.
	Air in system.	Bleed system.
	Lack of fluid in master cylinders.	Fill and bleed if necessary.
	Brake master cylinder defective.	Repair or replace master cylinder.

**5-43. BRAKE MASTER CYLINDERS.** The brake master cylinders, located just forward of the pilot rudder pedals, are actuated by applying pressure at the top of the rudder pedals. A small reservoir is incorporated into each brake master cylinder to supply it with fluid. When dual brakes are installed, mechanical linkage permits the copilot pedals to operate the brake master cylinders.

**5-44. BRAKE MASTER CYLINDER REMOVAL AND INSTALLATION.**

- a. Remove bleeder screw at wheel brake assembly and drain hydraulic fluid from brake system.
- b. Remove front seats and rudder bar shield for access to the brake master cylinders.
- c. Disconnect parking brake linkage and disconnect brake master cylinders from rudder pedals.
- d. Disconnect hydraulic hose from brake master cylinders and remove cylinders.
- e. Plug or cap hydraulic fittings, hose, and lines to prevent entry of foreign material.
- f. Reverse the preceding to install brake master cylinders. After installation, fill and bleed brake system as outlined in paragraph 5-51.

**5-45. BRAKE MASTER CYLINDER REPAIR.** Figure 5-12 may be used as a guide during disassembly, repair, and re-assembly of the brake master cylinders. Repair of the cylinders is limited to installation of new parts, cleaning, and adjustment. Use clean hydraulic fluid as a lubricant during assembly of the cylinders.

**5-46. HYDRAULIC BRAKE LINES** are of rigid tubing, except for flexible hose used at the brake master cylinders. A separate line is used to connect each brake master cylinder to its corresponding wheel brake cylinder. Install new lines and hose for damaged parts.

**5-47. WHEEL BRAKE ASSEMBLIES.** Wheel brake assemblies use a disc which is attached to the main wheel with the wheel thru-bolts or capscrews and a floating brake cylinder attached to the torque plate which is connected to the axle. (Refer to figure 5-3.)

**5-48. WHEEL BRAKES REMOVAL.** Wheel brake assemblies are the floating type and can be removed after disconnecting brake line and removing the back plate. See figure 5-3. The brake disc is removed after wheel removal and disassembly. To remove the torque plate on the flat gear, remove wheel and axle as outlined in paragraph 5-16. To remove the torque plate on the tubular gear, remove four bolts attaching torque plate to axle and work torque plate from spring-strut.

**5-49. WHEEL BRAKE INSPECTION AND REPAIR.**

- a. Clean all parts except brake linings and O-rings in dry cleaning solvent and dry thoroughly.
- b. New O-rings are usually installed at each overhaul. If O-rings re-use is necessary, they should be wiped with a clean cloth soaked in hydraulic fluid and inspected for damage.

**NOTE**

Thorough cleaning is important. Dirt and chips are the greatest single cause of malfunctions in the hydraulic brake systems.

- c. Check brake lining for deterioration and maximum permissible wear. See paragraph 5-49 for wear limits of the brake lining.
- d. Inspect brake cylinder wall for scores or roughness. A scored or rough wall surface will leak or cause rapid O-ring wear. If damaged, install a new cylinder.
- e. If the anchor bolts on the brake assembly are nicked, gouged, or corroded, they shall be sanded smooth to prevent binding with the pressure plate or torque plate. When new anchor bolts are to be installed, press out old bolts and drive new bolts in with a soft mallet.
- f. Inspect brake disc. If excessively warped or scored, or worn to a thickness of 0.190-inch, the brake disc should be replaced with a new part. Sand smooth small nicks and scratches.

**5-50. WHEEL BRAKE REASSEMBLY.** Use figure 5-3 as a guide during assembly of wheel brake assembly. Lubricate parts with clean hydraulic fluid and assemble components with care to prevent damage to O-rings and other components of the assembly.

**5-51. WHEEL BRAKE INSTALLATION.** Place brake assembly in position with pressure plate in place, then install back plate. If the brake disc was removed, install as wheel is assembled. If the torque plate was removed, install as outlined in paragraph 5-17 for the flat gear. On the tubular gear, install torque plate on axle with four bolts (see paragraph 5-19.)

**5-52. CHECK BRAKE LINING WEAR.** New brake lining should be installed when they are worn to a minimum thickness of 3/32-inch. Visually compare a 3/32-inch strip of material held adjacent to each lining to measure the thickness of the lining. The shank end of a correct size drill bit makes an excellent tool for checking minimum thickness of the brake linings.

**5-53. BRAKE LINING INSTALLATION.** (See figure 5-3.)

- a. Remove bolts securing back plate and remove back plate.
- b. Pull the brake cylinder out of torque plate and slide pressure plate off anchor bolts.
- c. Place back plate on a table with lining side down flat. Center a 9/64 inch diameter (or slightly smaller) punch in the rolled rivet, and hit the punch sharply with a hammer driving out the rivet. Punch out all rivets securing the lining to the back plate and pressure plate in the same manner.

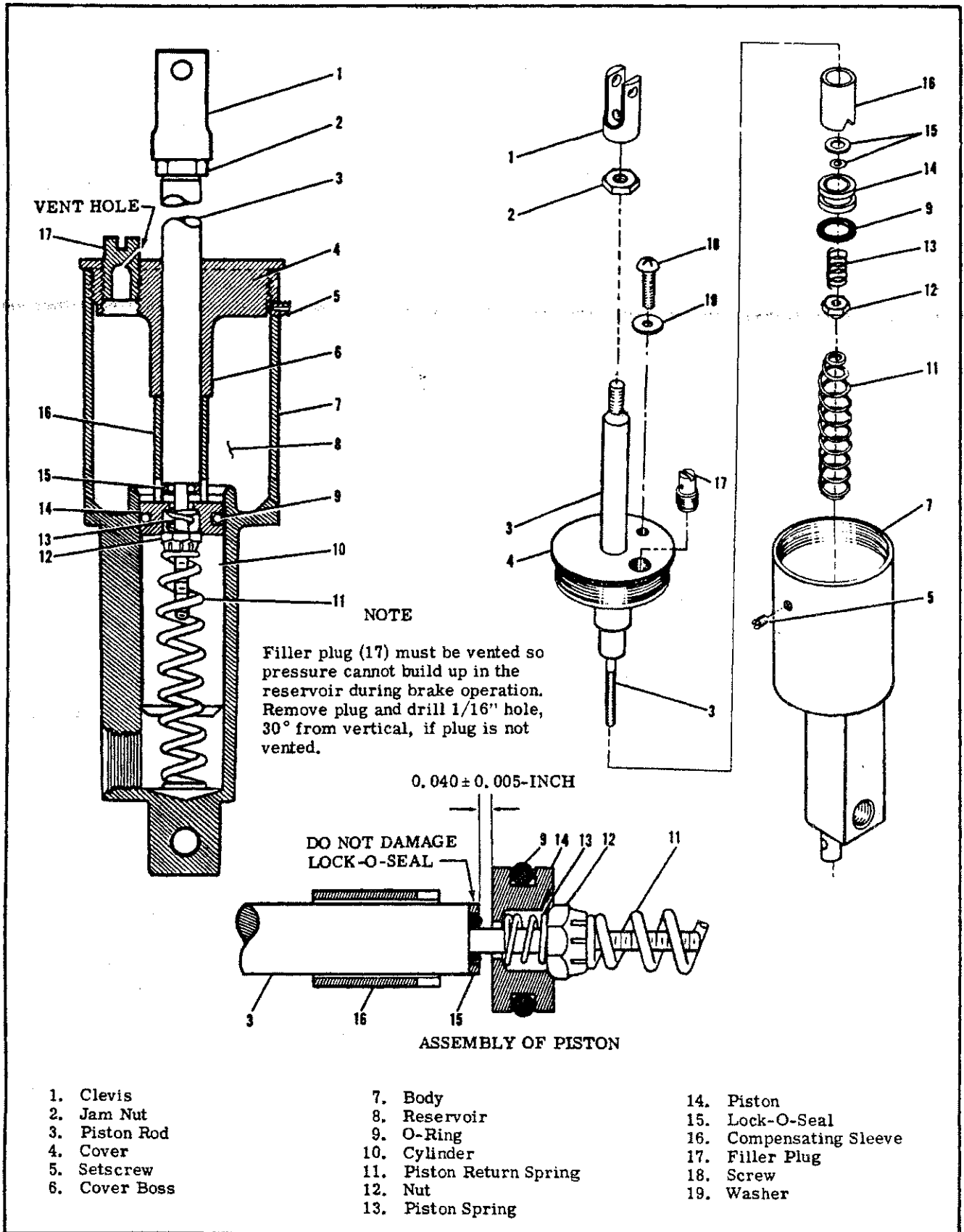

Figure 5-13. Brake Master Cylinder

#### NOTE

A rivet setting kit, Part No. R561, is available from the Cessna Service Parts Center. This kit consists of an anvil and punch.

- d. Clamp the flat side of the anvil in a vise.
- e. Align new lining on back plate and place brake rivet in hole with rivet head in the lining. Place the rivet head against the anvil.
- f. Center the rivet setting punch on the lips of the rivet. While holding the back plate down firmly against the lining, hit the punch with a hammer to set the rivet. Repeat blows on the punch until lining is firmly against the back plate.
- g. Realign the lining on the back plate and install rivets in the remaining holes.
- h. Install new lining on the pressure plate in the same manner.
- i. Position pressure plate on anchor bolts and place cylinder in position so that anchor bolts slide into the torque plate.
- j. Install back plate with bolts and washers.

5-54. BRAKE SYSTEM BLEEDING. Bleeding with a clean hydraulic pressure source connected to the wheel cylinder bleeder valve is recommended.

- a. Remove brake master cylinder filler plug and screw a flexible hose with an appropriate fitting into the filler hole at top of the brake master cylinder.

Immerse the free end of the flexible hose in a container with enough hydraulic fluid to cover the end of the hose.

- b. Connect a clean hydraulic pressure source, such as a hydraulic hand pump or Hydro Fill unit, to the wheel cylinder bleeder valve.

- c. As fluid is pumped into the system, observe the immersed end of the hose at the brake master cylinder for evidence of air bubbles being forced from the brake system. When bubbling has ceased, tighten bleeder valve and remove hydraulic pressure source.

#### NOTE

Ascertain that the free end of the hose from the brake master cylinder remains immersed during the entire bleeding process.

- d. Remove flexible hose and install filler plug in brake master cylinder.

5-55. PARKING BRAKE SYSTEM. (See figure 5-14.)

The parking brake system uses a handle and ratchet mechanism connected by a cable to linkage at the brake master cylinders. Pulling out on the handle depresses both brake master cylinder piston rods and the handle ratchet locks the handle in this position until the handle is turned and released.



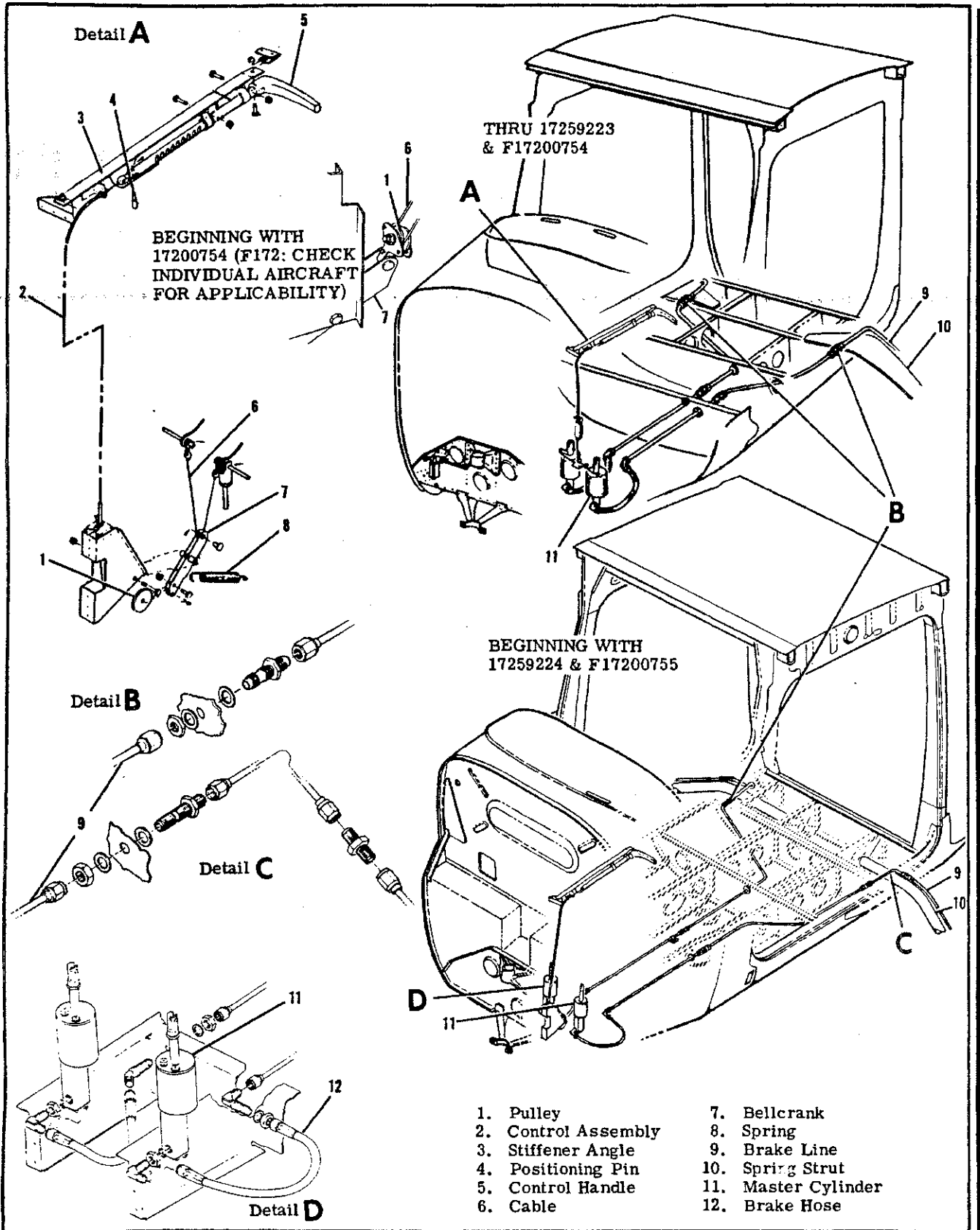

Figure 5-14. Parking Brake System



SECTION 6

AILERON CONTROL SYSTEM

TABLE OF CONTENTS

	Page		
<b>AILERON CONTROL SYSTEM</b> . . . . .	6-1	<b>Repair</b> . . . . .	6-4
Description . . . . .	6-1	Installation . . . . .	6-4
Trouble shooting . . . . .	6-1	<b>Cables and Pulleys</b> . . . . .	6-4
Control "U" . . . . .	6-4	Removal and Installation . . . . .	6-4
Description . . . . .	6-4	<b>Ailerons</b> . . . . .	6-6
Removal and Installation . . . . .	6-4	Removal . . . . .	6-6
Repair . . . . .	6-4	Installation . . . . .	6-6
Aileron Bellcrank . . . . .	6-4	Repair . . . . .	6-7
Removal . . . . .	6-4	<b>Rigging</b> . . . . .	6-7

6-1. AILERON CONTROL SYSTEM. (Refer to figure 6-1.)

pulleys, sprockets and roller chains, all of which, link the control wheels to the ailerons. A control "U" interconnects the control wheels to the aileron cables.

6-2. DESCRIPTION. The aileron control system is comprised of push-pull rods, bellcranks, cables,

6-3. TROUBLE SHOOTING.

NOTE

Due to remedy procedures in the following trouble shooting chart it may be necessary to re-rig system, refer to paragraph 6-18.

TROUBLE	PROBABLE CAUSE	REMEDY
LOST MOTION IN CONTROL WHEEL.	Loose control cables.	Adjust cables to proper tension.
	Broken pulley or bracket, cable off pulley or worn rod end bearings.	Replace worn or broken parts, install cables correctly.
	Sprung bellcranks.	Replace bellcranks.
	Loose chains.	Adjust to proper tension.

6-3. TROUBLE SHOOTING (Cont).

TROUBLE	PROBABLE CAUSE	REMEDY
RESISTANCE TO CONTROL WHEEL MOVEMENT.	Cables too tight.	Adjust cables to proper tension.
	Pulleys binding or cable off.	Replace defective pulleys. Install cables correctly.
	Bellcrank distorted or damaged.	Replace bellcrank.
	Clevis bolts in system too tight.	Loosen, then tighten properly and safety.
	Rusty chain.	Replace chain.
	Chain binding with sprockets.	Replace defective parts.
	Defective U-joints.	Replace defective U-joints.
CONTROL WHEELS NOT LEVEL WITH AILERONS NEUTRAL.	Improper adjustment of chains or cables.	Adjust in accordance with paragraph 6-18.
	Improper adjustment of aileron push-pull rods.	Adjust push-pull rods to obtain proper alignment.
DUAL CONTROL WHEELS NOT COORDINATED.	Chains improperly adjusted.	Adjust in accordance with paragraph 6-18.
INCORRECT AILERON TRAVEL.	Push-pull rods not adjusted properly.	Adjust in accordance with paragraph 6-18.
	Worn bellcrank stop bushings or bellcrank slots.	Replace worn parts.

**SHOP NOTES:**

---



---



---



---



---



---



---



---

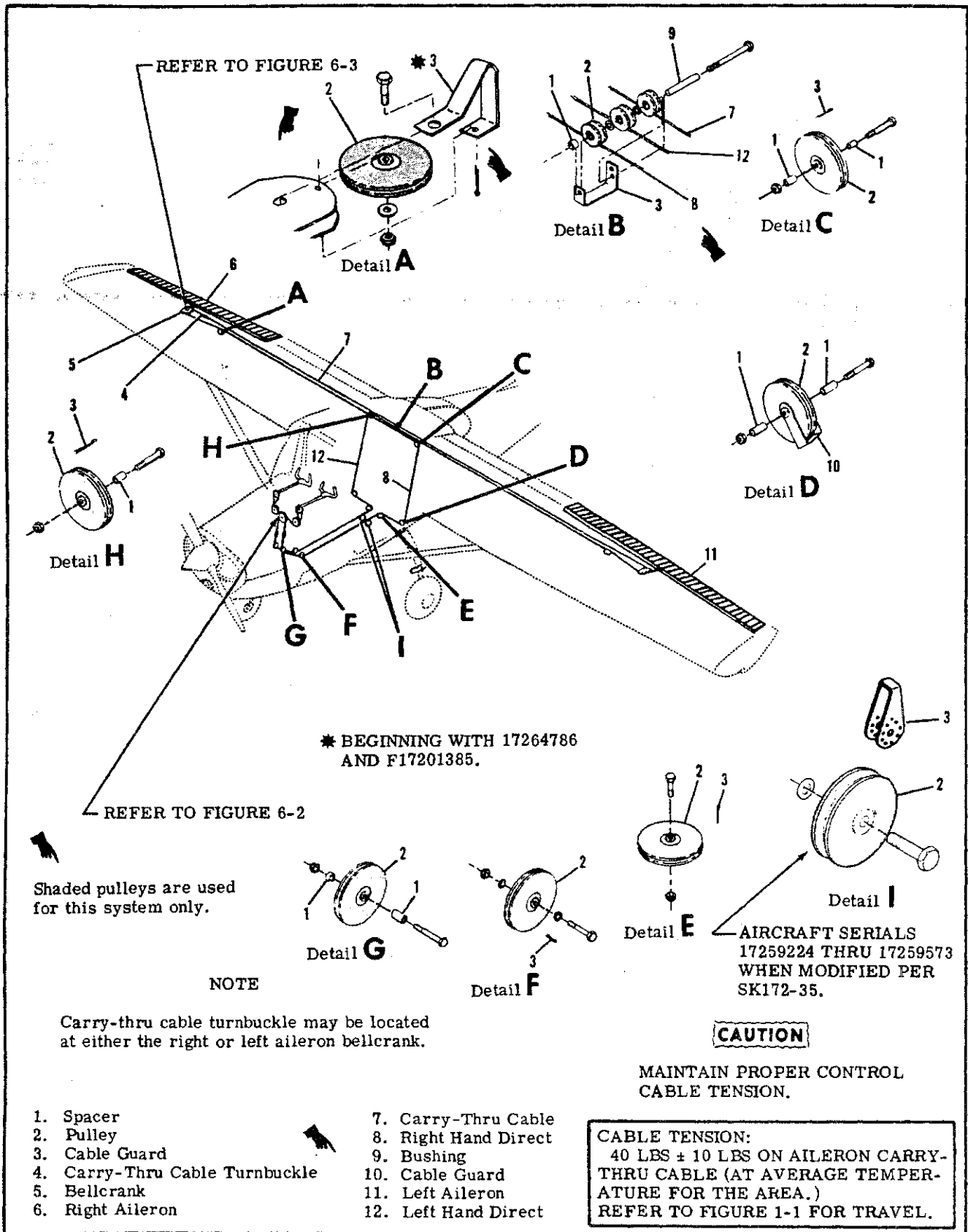

Figure 6-1. Aileron Control System

6-4. CONTROL "U". (Refer to figure 6-2.)

6-5. DESCRIPTION. The control "U" transforms rotation of the control wheels into pulling motion on the aileron cables by means of sprockets and chains. The "U" is pivoted at the lower end to operate the elevator control system.

6-6. REMOVAL AND INSTALLATION.

- a. Disconnect battery cables and insulate terminals as a safety precaution.
- b. Remove pedestal cover as outlined in paragraph 9-13.
- c. Remove control yoke cover (21).
- d. Remove rudder bar shields, carpeting and plates as necessary for access to lower end of control "U."
- e. Remove radios, radio cooling pans, dust covers and associated hardware as necessary.
- f. Remove glove box.
- g. Remove cabin air cooling hose directly below right hand side of instrument panel.
- h. Remove engine controls and cabin air controls as necessary.
- i. Remove right hand forward side upholstery panel.
- j. Remove bolt from each end of parking brake assembly and swing assembly away from working area.
- k. Remove bolt attaching bearing (11) to control "U" and remove bearing and associated hardware.
- l. Drill out rivets attaching instrument panel support (after completion of step "k") and remove support.
- m. Drill out rivets attaching right hand side panel to pedestal structure and remove panel.
- n. Remove safety wire and disconnect turnbuckles (17).
- o. Remove bolts (12) attaching control wheel tubes to universal joints (13).
- p. Remove bolt (19) attaching push-pull tube (18) to Control "U."
- q. Remove pivot bolt (20) and carefully work control "U" out from under right hand side of instrument panel.
- r. Reverse preceding steps for reinstallation.

NOTE

To prevent loss of strength and to ease reinstallation of right hand pedestal structure side panel, machine screws and nuts may be installed in the two upper rivet holes, provided at least No. 6 screws are installed.

- s. Rig aileron control system in accordance with paragraph 6-18 and safety turnbuckles (17).
- t. Check and/or rig elevator control system in accordance with paragraph 8-14.
- u. Check and/or rig all engine and cabin air controls.
- v. Check all radios and electrical components which may have been disconnected or become inoperative while performing the preceding steps.
- w. Reinstall all items removed for access.

6-7. REPAIR. Repair consists of replacing worn, damaged or defective shafts, bearings, bushings, sprockets, roller chains, universal joints or other components. Refer to Section 2 for lubrication requirements.

6-8. AILERON BELLCRANK. (Refer to figure 6-3.)

6-9. REMOVAL.

- a. Remove access plate inboard of each bellcrank on underside of wing.
- b. Relieve control cable tension by loosening turnbuckle barrel (17).
- c. Disconnect control cables from bellcrank. Retain all spacers (12).
- d. Disconnect aileron push-pull rod (8) at bellcrank.
- e. Remove nuts, washers and bolts securing bellcrank stop bushing (15) and bellcrank (7) to wing structure.
- f. Remove bellcrank through access opening, using care that bushing (5) is not dropped from bellcrank.

NOTE

Brass washers (11) may be used as shims between lower end of bellcrank and wing channel (9). Retain these shims. Tape open ends of bellcrank to prevent dust and dirt from entering bellcrank needle bearings (6).

6-10. REPAIR. Repair of bellcranks consists of replacement of defective parts. If needle bearings are dirty or in need of lubrication, clean thoroughly and lubricate as outlined in Section 2.

6-11. INSTALLATION.

- a. Place bushing (5) and stop-bushing (15) in bellcrank (7) and position bellcrank in wing.
- b. Install brass washers (11) between lower end of bellcrank and wing channel (9) to shim out excess clearance.
- c. Install bellcrank pivot bolt (4), washers and nut.
- d. Position bellcrank stop-bushing and install attaching bolt (16), washers and nut.
- e. Connect cables and push-pull rod to bellcrank.
- f. Rig aileron system in accordance with applicable paragraph in this section, safety turnbuckle (17) and reinstall all items removed for access.

6-12. CABLES AND PULLEYS. (Refer to figure 6-1.)

6-13. REMOVAL AND INSTALLATION.

- a. Remove access plates, wing root fairings and upholstery as required.
- b. Disconnect cables from aileron bellcranks and remove cable guards and pulleys as necessary to work cables free of aircraft.

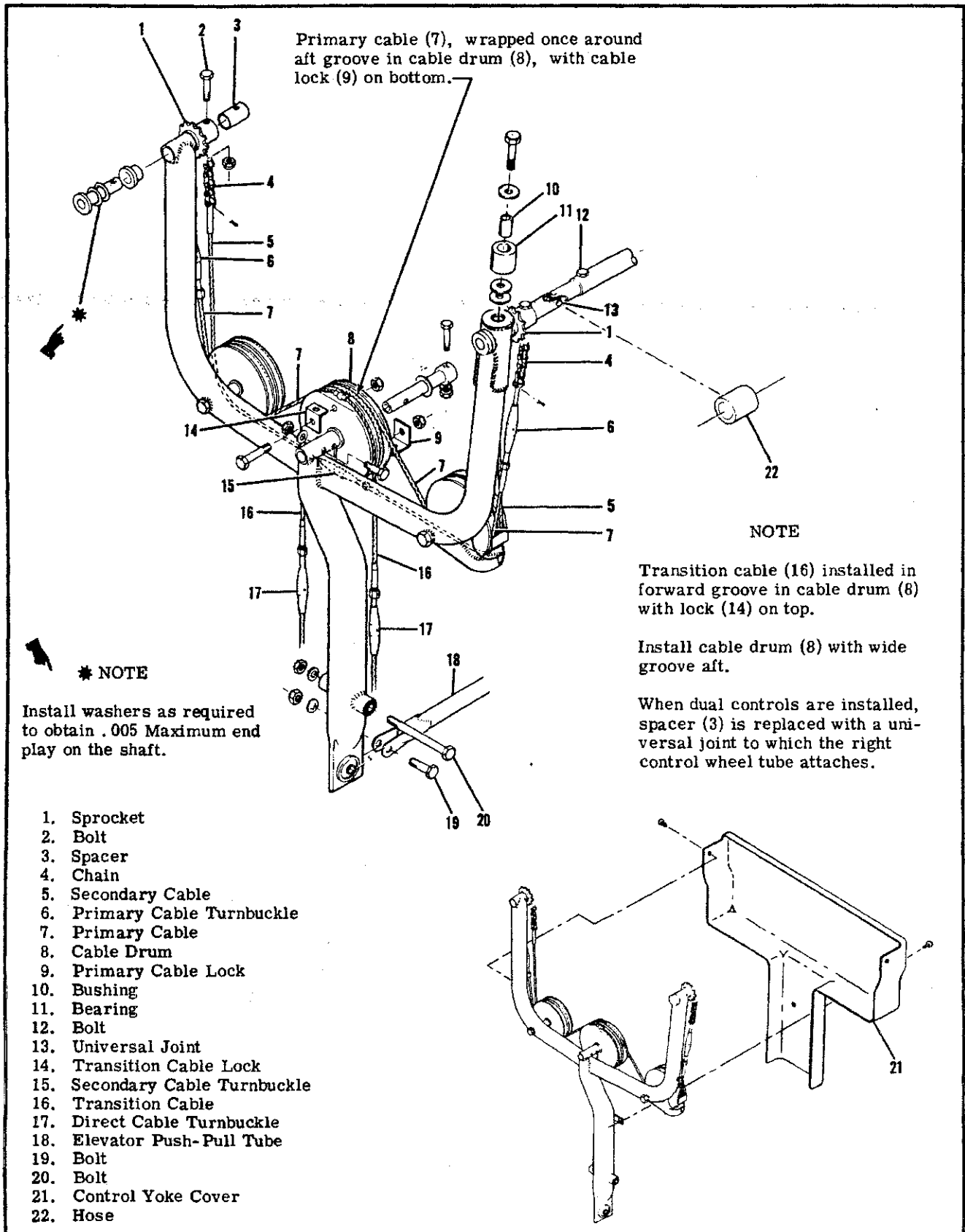

Figure 6-2. Control "U" Installation

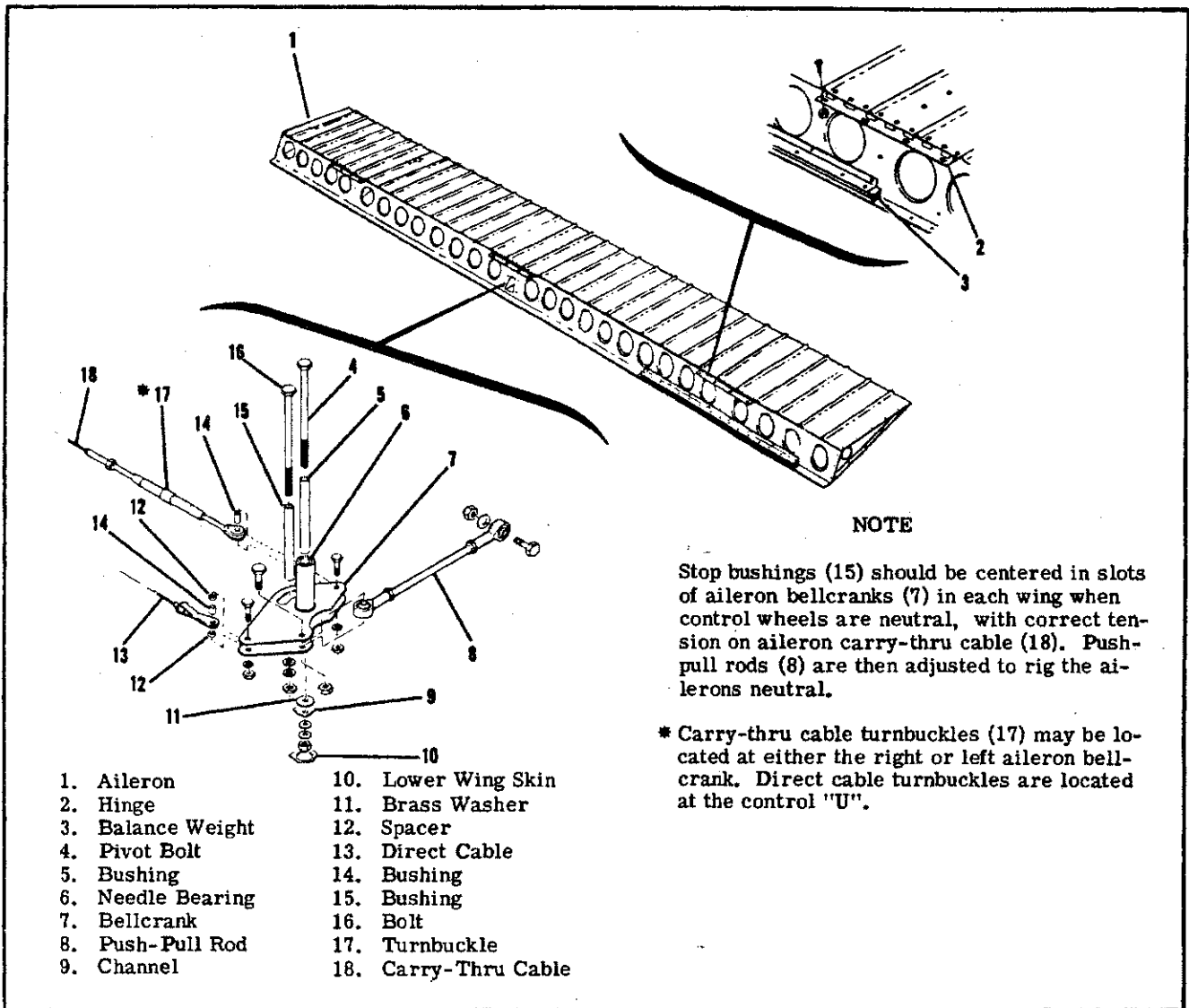

Figure 6-3. Aileron Installation

**NOTE**

To ease routing of cables, a length of wire may be attached to end of cable before being withdrawn from aircraft. Leave wire in place, routed through structure; then attach cable being installed and use to pull cable into position.

c. After cable is routed, install pulleys and cable guards. Ensure cable is positioned in pulley groove before installing guard.

d. Rig aileron system in accordance with applicable paragraph in this section, safety turnbuckles and install access plates, fairings and upholstery removed in step "a."

6-14. AILERONS. (Refer to figure 6-3.)

**6-15. REMOVAL.**

- a. Disconnect push-pull rod (8) at aileron.
- b. Remove screws and nuts attaching aileron hinges (2) to trailing edge of wing.
- c. Using care, pull aileron out and down to slide hinges from under wing skin and auxiliary spar reinforcements.

**6-16. INSTALLATION.**

- a. Position aileron hinges between skin and auxiliary spar reinforcements and install screws and nuts attaching hinges to trailing edge of wing.
- b. Attach push-pull rod (8) to aileron.

**NOTE**

If rigging was correct and push pull rod adjustment was not disturbed, it should not be necessary to rig system.



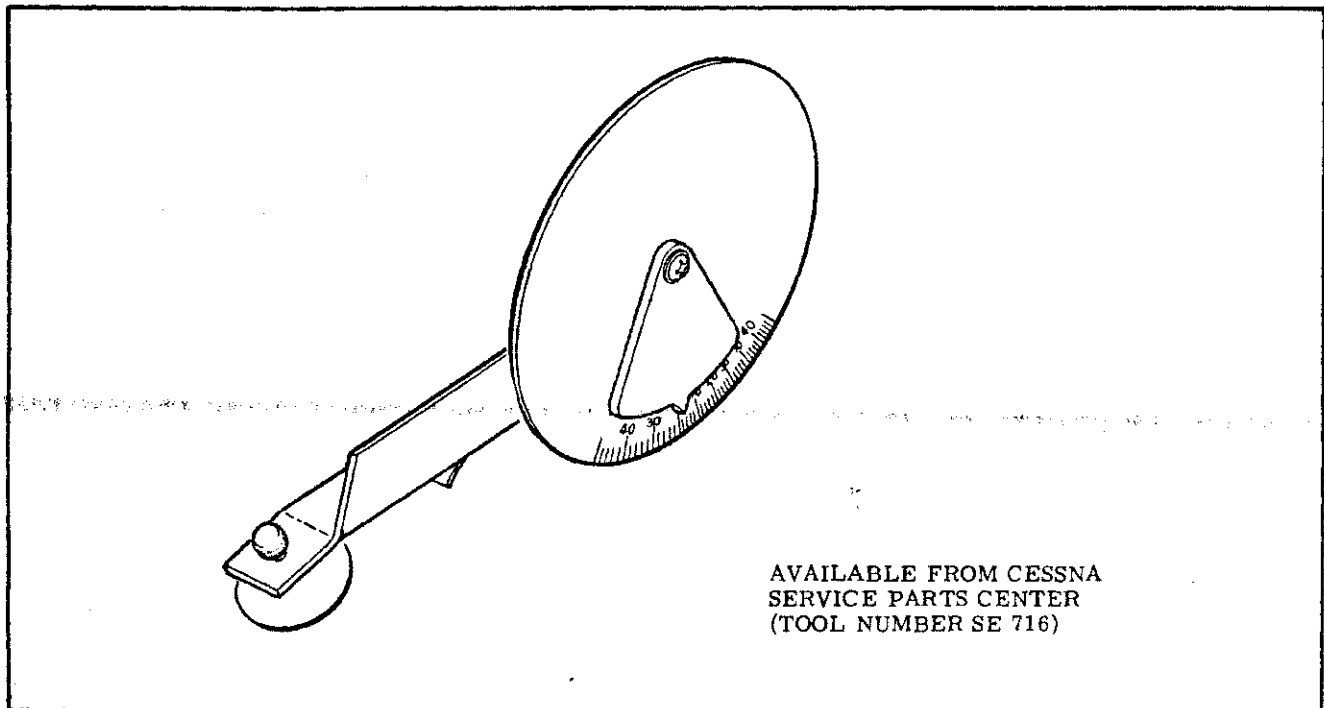

Figure 6-4. Inclinometer for Measuring Control Surface Travel

c. Check aileron travel and alignment, rig if necessary, in accordance with applicable paragraph in this section.

6-17. REPAIR. Aileron repair may be accomplished in accordance with instructions outlined in Section 18. Before installation, ensure balance weights and hinges are securely attached.

6-18. RIGGING. (Refer to figure 6-2.)

a. Check primary control cable (7) is in aft groove of cable drum (8) and wrapped once around drum. The primary cable lock (9) is installed at bottom of drum and transition cable lock (14) is installed at top.

b. With control wheels neutral, check chain ends (4) are approximately same distance from sprockets (1).

c. Keeping control wheels neutral, tighten turnbuckles (6) so control wheels are level in neutral position (synchronized), with enough tension on cables to remove slack from chains (4), without binding. Results of adjusting turnbuckles are as follows:

1. Loosening primary cable turnbuckles (6) and tightening secondary cable turnbuckle (15) at center of control "U" will move inboard sides of both control wheels down.

2. Tightening either primary control cable turnbuckle and loosening secondary cable turnbuckle at

center of control "U" will move outboard side of applicable control wheel down.

d. Tape a bar across both control wheels to hold them in neutral position.

e. Adjust direct cable turnbuckles (17) below control "U" and single carry-thru turnbuckle (index 17, figure 6-3) at aileron bellcrank (index 7, figure 6-3) so bellcrank stop bushings (index 15, figure 6-3) are centered in both bellcrank slots with  $40 \pm 10$  pounds tension on aileron carry-thru cable (index 18, figure 6-3). Disregard tension on direct cables, which will be different than tension on carry-thru cable.

f. Adjust push-pull rods (index 8, figure 6-3) at each aileron until ailerons are neutral with reference to trailing edge of wing flaps. Be sure wing flaps are fully up when making this adjustment.

g. Safety all turnbuckles by the single-wrap method using 0.040-inch monel safety wire.

h. Remove bar from control wheels and install all items removed for access.

i. Check aileron travel, using inclinometer illustrated in figure 6-4.

### WARNING

Be sure ailerons move in correct direction when operated by control wheel.

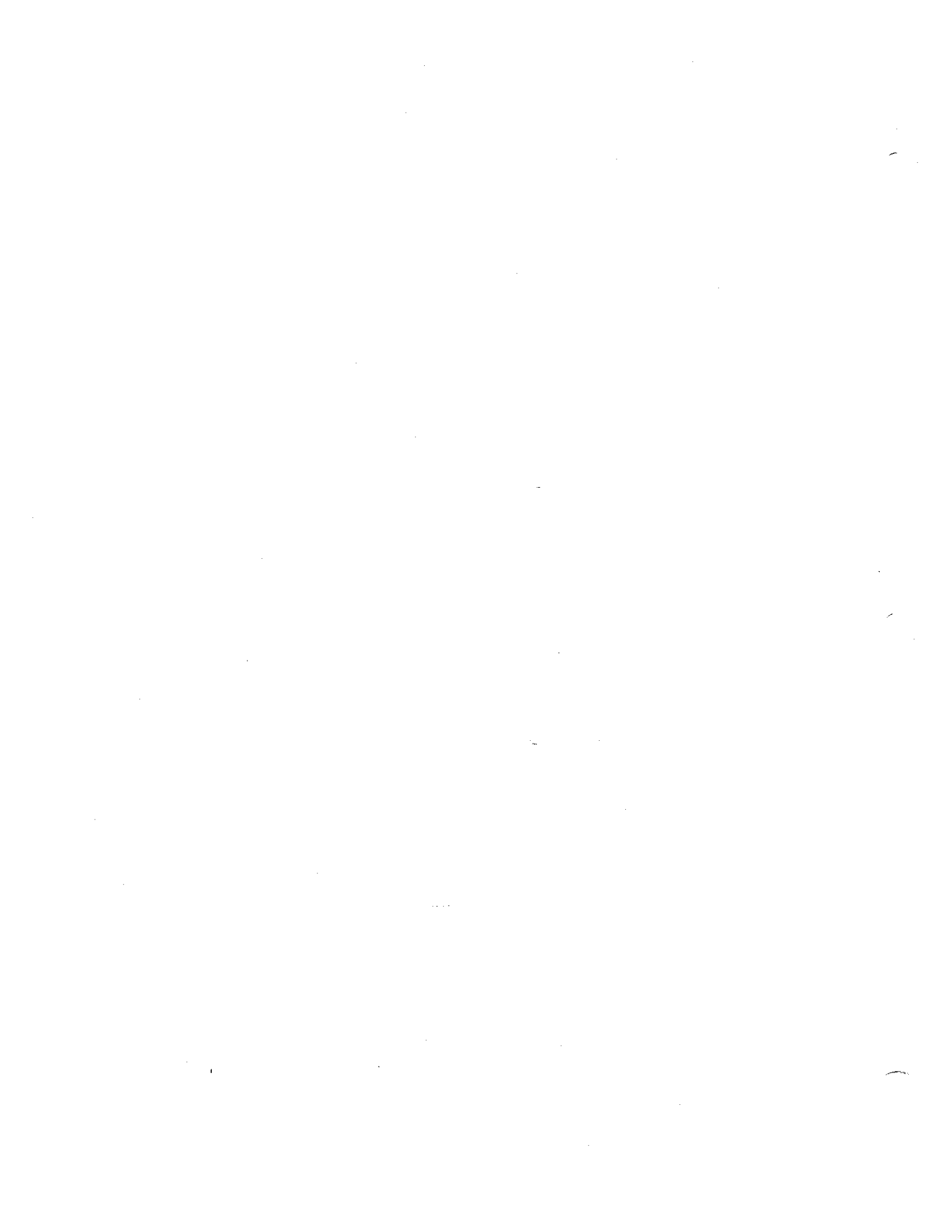

SECTION 7

WING FLAP CONTROL SYSTEM

TABLE OF CONTENTS

	Page		
WING FLAP CONTROL SYSTEM . . . . .	7-1	Flaps . . . . .	7-8
Description . . . . .	7-1	Removal and Installation . . . . .	7-8
Operational Check . . . . .	7-1	Repair . . . . .	7-8
Trouble Shooting . . . . .	7-2	Flap Position Transmitter . . . . .	7-8
Flap Motor and Transmission Assembly . . . . .	7-3	Removal and Installation . . . . .	7-8
Removal and Installation. . . . .	7-3	Adjustment . . . . .	7-8
Repair. . . . .	7-3	Cables and Pulleys . . . . .	7-8
Drive Pulleys . . . . .	7-3	Removal and Installation . . . . .	7-8
Removal and Installation . . . . .	7-3	Rigging . . . . .	7-8
Repair . . . . .	7-8		

7-1. WING FLAP CONTROL SYSTEM. (Refer to figure 7-1.)

7-2. DESCRIPTION. The wing flap control system is comprised of an electric motor and transmission assembly, drive pulleys, push-pull rods, cables, pulleys and a flap position indicator. Power from the motor and transmission assembly is transmitted to the flaps by a system of drive pulleys, cables and push-pull rods. Electrical power to the motor is controlled by a 3-position switch mounted on the instrument panel. The flap position indicator is calibrated to show degrees of extension.

7-3. OPERATIONAL CHECK.

- a. Operate flaps through their full range of travel, observing for uneven or jumpy motion, binding and lost motion in system. Ensure flaps are moving together through their full range of travel.
- b. THRU AIRCRAFT SERIALS 17259904 AND F172-00804 WHEN NOT MODIFIED IN ACCORDANCE WITH FIGURE 7-2, SHEET 3. Attempt to overrun travel extremes and check for transmission free-wheeling at full up and full down positions.
- c. BEGINNING WITH AIRCRAFT SERIALS 17259905 AND F17200805 AND ALL AIRCRAFT MODIFIED IN ACCORDANCE WITH FIGURE 7-2, SHEET 3. Check

for positive shut-off of motor at the flap travel extremes, FLAP MOTOR MUST STOP OR DAMAGE WILL RESULT.

d. Check that flaps are not sluggish in operation. In flight at 100 mph, indicated airspeed, flaps should fully extend in approximately 9 seconds and retract in approximately 5 seconds. On the ground, with engine running, the flaps should extend or retract in approximately 6 seconds.

e. With flaps full UP, mount an inclinometer on one flap and set to 0°. Lower flaps to full DOWN position and check flap angle as specified in figure 1-1. Check approximate mid-range percentage setting against degrees as indicated on inclinometer. Repeat the same procedure for the opposite flap.

NOTE

An inclinometer for measuring control surface travel is available from the Cessna Service Parts Center. Refer to figure 6-4.

f. Remove access plates adjacent to flap drive pulleys and attempt to rock pulleys to check for bearing wear.

g. Inspect flap rollers and tracks for evidence of binding and defective parts.

7-4. TROUBLE SHOOTING.

NOTE

Due to remedy procedures in the following trouble shooting chart it may be necessary to re-rig system, refer to paragraph 7-19.

TROUBLE	PROBABLE CAUSE	REMEDY
BOTH FLAPS FAIL TO MOVE.	Popped circuit breaker.	Reset and check continuity. Replace breaker if defective.
	Defective switch.	Place jumper across switch. Replace switch if defective.
	Defective motor.	Remove and bench test. Replace motor if defective.
	Broken or disconnected wires.	Run continuity check of wiring. Connect or repair wiring as necessary.
	Disconnected or defective transmission.	Connect transmission. Remove, bench test and replace transmission if defective.
	Defective limit switch.	Check continuity of switches. Replace switches found defective.
BINDING IN SYSTEM AS FLAPS ARE RAISED AND LOWERED.	Cables not riding on pulleys.	Open access plates and observe pulleys. Route cables correctly over pulleys.
	Bind in drive pulleys.	Check drive pulleys in motion. Replace drive pulleys found defective.
	Broken or binding pulleys.	Check pulleys for free rotation or breaks. Replace defective pulleys.
	Frayed cable.	Check condition of cables. Replace defective cables.
	Flaps binding on tracks.	Observe flap tracks and rollers. Replace defective parts.
LEFT FLAP FAILS TO MOVE.	Disconnected or broken cable.	Check cable tension. Connect or replace cable.
	Disconnected push-pull rod.	Attach push-pull rod.
INCORRECT FLAP TRAVEL.	Incorrect rigging.	Refer to paragraph 7-19.
	Defective limit switch.	Check continuity of switches. Replace switches found defective.
FLAPS FAIL TO RETRACT.	Disconnected or defective UP limit switch.	Check continuity of switch. Connect or replace switch.

7-4. TROUBLE SHOOTING (Cont).

TROUBLE	PROBABLE CAUSE	REMEDY
FLAPS FAIL TO EXTEND.	Disconnected or defective DOWN limit switch.	Check continuity of switch. Connect or replace switch.

7-5. FLAP MOTOR AND TRANSMISSION ASSEMBLY.

7-6. REMOVAL AND INSTALLATION.

a. THRU AIRCRAFT SERIALS 17259904 AND F172-00804 WHEN NOT MODIFIED IN ACCORDANCE WITH SK150-37 AND WHEN NOT MODIFIED IN ACCORDANCE WITH FIGURE 7-2, SHEET 3. (Refer to figure 7-2, sheet 1.)

1. Run flaps to full DOWN position.
2. Disconnect battery cables at the battery and insulate cable terminals as a safety precaution.
3. Remove access plates adjacent to drive pulley and motor assembly on right wing.

NOTE

Remove motor (1), transmission (4), hinge assembly (2) and actuating tube (6) from aircraft as a unit on aircraft equipped with standard fuel tanks. On aircraft equipped with long range tanks, detach motor and transmission assembly from hinge assembly (2) prior to removal by removing bolt (5).

4. Remove bolt (18) securing actuating tube (6) to drive pulley (9).
5. Screw actuating tube (6) IN toward transmission (4) by hand to its shortest length.
6. Remove bolt (3) securing flap motor hinge (2) to wing, or if long range fuel tanks are installed, remove bolt (5) securing transmission to hinge assembly. Retain brass washer between hinge and wing structure for use on reinstallation.
7. Disconnect motor electrical wiring (21) at quick-disconnects.
8. Using care, work assembly from wing through access opening.
9. Reverse the preceding steps for reinstallation. If the hinge assembly (2) was removed from the transmission (4) for any reason, ensure the short end of hinge is reinstalled toward the top.
10. Complete an operational check as outlined in paragraph 7-3 and re-rig system in accordance with paragraph 7-19.

b. THRU AIRCRAFT SERIALS 17259904 AND F172-00804 WHEN MODIFIED IN ACCORDANCE WITH SK-150-37 AND WHEN NOT MODIFIED IN ACCORDANCE WITH FIGURE 7-2, SHEET 3. (Refer to figure 7-2, sheet 2.)

1. Complete steps 1, 3 and 4 of subparagraph "a."

2. Run flap motor to place actuating tube (4) IN to its shortest length.

3. Complete steps 2, 6, 7, 8, 9 and 10 of subparagraph "a."

c. BEGINNING WITH AIRCRAFT SERIALS 172-59905, F17200805 AND ALL AIRCRAFT MODIFIED IN ACCORDANCE WITH FIGURE 7-2, SHEET 3. (Refer to figure 7-2, sheets 2 and 3.)

1. Complete steps 1 thru 7 of subparagraph "a."
2. Disconnect electrical wiring at limit switches (29 and 32). Tag wires for reference on reinstallation.
3. Complete steps 8, 9 and 10 of subparagraph "a."

7-7. REPAIR. Repair consists of replacement of motor, transmission, coupling, actuating tube and associated hardware. Bearings in hinge assembly may also be replaced. Lubricate as outlined in Section 2.

7-8. DRIVE PULLEYS. (Refer to figure 7-2.)

7-9. REMOVAL AND INSTALLATION.

- a. Remove access plates adjacent to drive pulley (9) in right wing.
- b. Unzip or remove headliner as necessary for access to turnbuckles (index 6, figure 7-1), remove safety wire and loosen turnbuckles.
- c. Remove bolt (15) securing flap push-pull rod (10) to drive pulley (9) and lower RIGHT flap gently.
- d. Remove bolt (18) securing actuating tube (6) to drive pulley (9) and lower LEFT flap gently. Retain bushing.
- e. Remove cable locks (8) securing control cables to drive pulley (9). Tag cables for reference on reinstallation.
- f. Remove pin (17) attaching transmitter rod (14) to arm (16).
- g. Remove bolt (7) attaching drive pulley (9) to wing structure.
- h. Using care, remove drive pulley through access opening, being careful not to drop bushing. Retain brass washer between drive pulley and wing structure for use on reinstallation. Tape open ends of drive pulley after removal to protect bearings.
- i. To remove left wing drive pulley, use this same procedure omitting steps "d" and "f."
- j. Reverse the preceding steps for reinstallation. Rig system in accordance with paragraph 7-19, safety turnbuckles and reinstall all items removed for access.

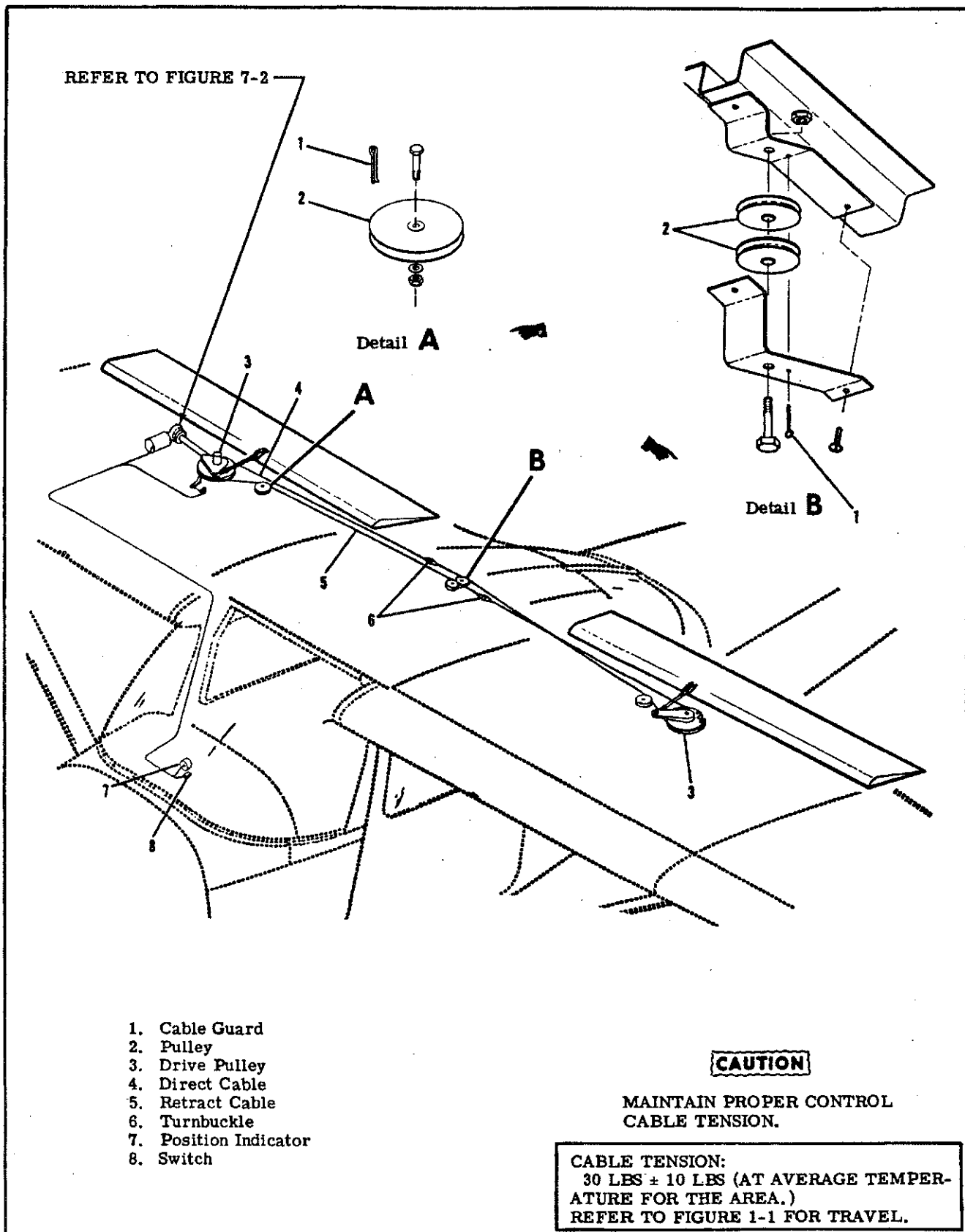
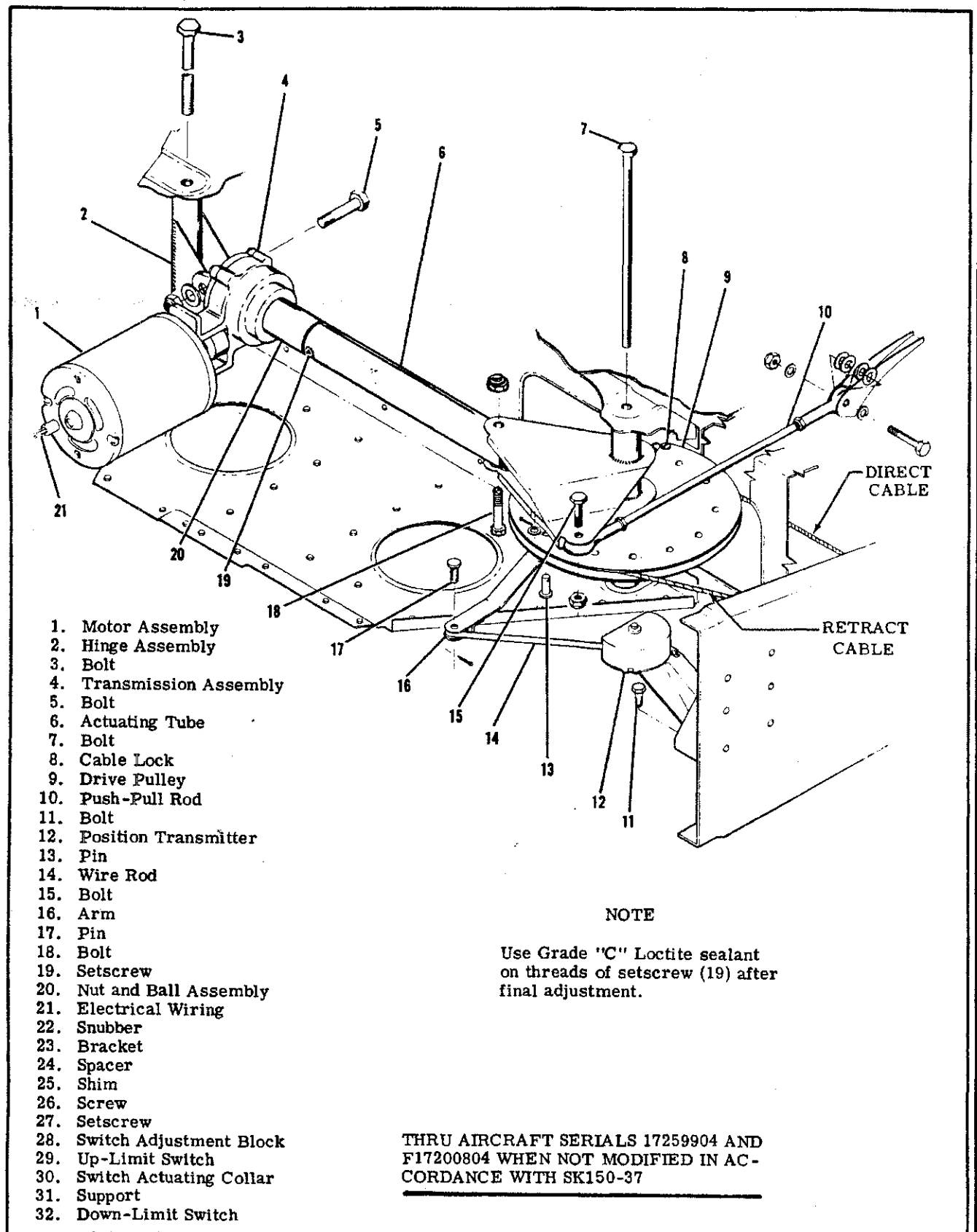

Figure 7-1. Wing Flap Control System



- 1. Motor Assembly
- 2. Hinge Assembly
- 3. Bolt
- 4. Transmission Assembly
- 5. Bolt
- 6. Actuating Tube
- 7. Bolt
- 8. Cable Lock
- 9. Drive Pulley
- 10. Push-Pull Rod
- 11. Bolt
- 12. Position Transmitter
- 13. Pin
- 14. Wire Rod
- 15. Bolt
- 16. Arm
- 17. Pin
- 18. Bolt
- 19. Setscrew
- 20. Nut and Ball Assembly
- 21. Electrical Wiring
- 22. Snubber
- 23. Bracket
- 24. Spacer
- 25. Shim
- 26. Screw
- 27. Setscrew
- 28. Switch Adjustment Block
- 29. Up-Limit Switch
- 30. Switch Actuating Collar
- 31. Support
- 32. Down-Limit Switch

**NOTE**

Use Grade "C" Loctite sealant on threads of setscrew (19) after final adjustment.

THRU AIRCRAFT SERIALS 17259904 AND F17200804 WHEN NOT MODIFIED IN ACCORDANCE WITH SK150-37

Figure 7-2. Flap Motor and Transmission Assembly (Sheet 1 of 3)

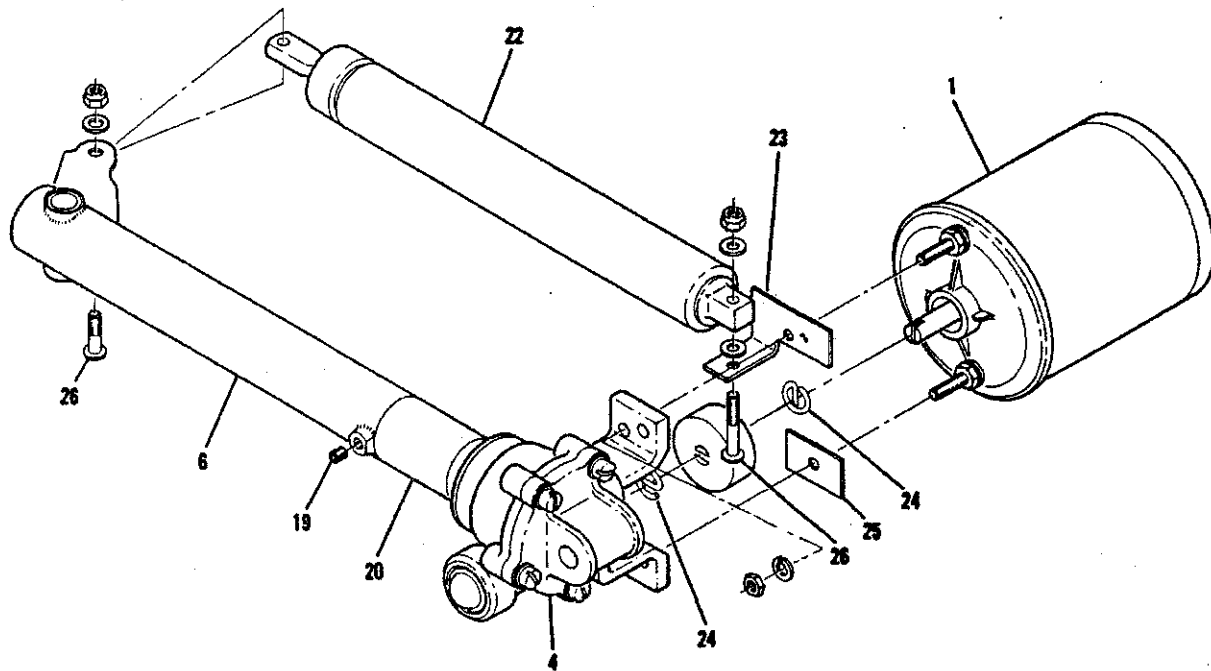

AIRCRAFT SERIALS 17251823 THRU 17259904 AND F17200086  
THRU F17200804 WHEN MODIFIED IN ACCORDANCE WITH  
SK150-37

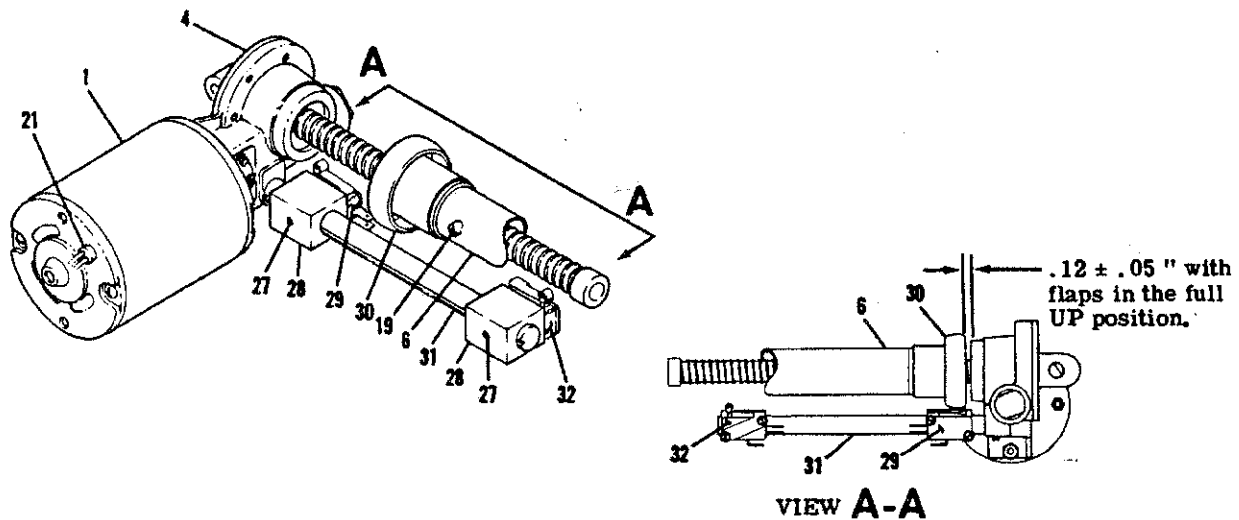

BEGINNING WITH AIRCRAFT SERIALS  
17259905 AND F17200805

Figure 7-2. Flap Motor and Transmission Assembly (Sheet 2 of 3)



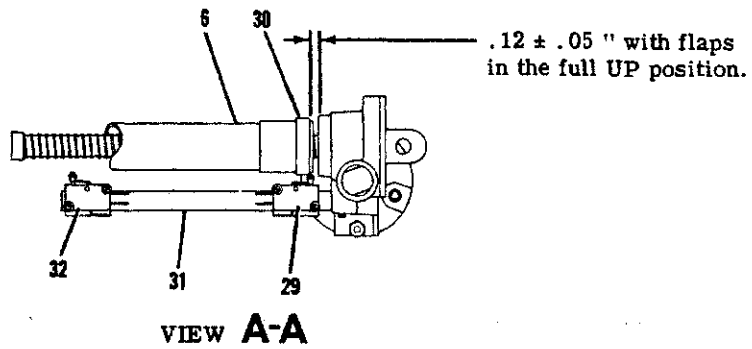
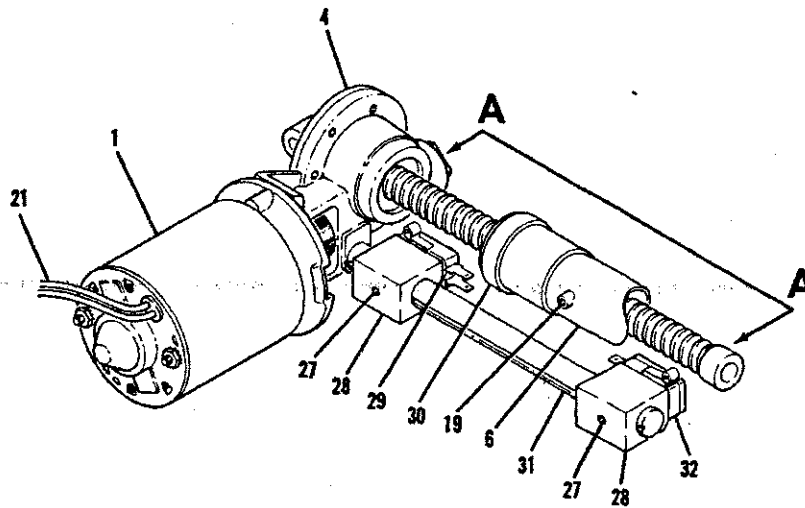

SK150-41 AND THIS FLAP ACTUATOR INSTALLATION IS EFFECTIVE ONLY WHEN USED AS A REPLACEMENT SPARE, OR ON PRODUCTION FLAP ACTUATOR INSTALLATIONS PRIOR TO AIRCRAFT SERIALS 17259905 AND F17200805

Figure 7-2. Flap Motor and Transmission Assembly (Sheet 3 of 3)

7-10. REPAIR. Repair is limited to replacement of bearings. Cracked, bent or excessively worn drive pulleys must be replaced. Lubricate bearings as outlined in Section 2.

#### NOTE

The right drive pulley (9) must be removed to detach position transmitter arm (16).

7-11. FLAPS. (Refer to figure 7-3.)

7-12. REMOVAL AND INSTALLATION.

- a. Run flaps to full DOWN position.
- b. Remove access plates (1) from top leading edge of flap.
- c. Disconnect push-pull rod (6) at flap bracket (7).
- d. Remove bolts (5) at each flap track. As flap is removed from wing, all washers, rollers and bushings will fall free. Retain these for reinstallation.
- e. Reverse the preceding steps for reinstallation. If push-pull rod (6) adjustment is not disturbed, re-rigging of system should not be necessary. Check flap travel and rig in accordance with paragraph 7-19, if necessary.

7-13. REPAIR. Flap repair may be accomplished in accordance with instructions outlined in Section 18.

7-14. FLAP POSITION TRANSMITTER. (Refer to figure 7-2.)

7-15. REMOVAL AND INSTALLATION.

- a. Remove access plate adjacent to drive pulley in right wing.
- b. Remove pin (17) attaching transmitter rod (14) to arm (16).
- c. Disconnect electrical wiring at transmitter quick-disconnects.
- d. Remove bolts (11) securing transmitter to wing structure and lift out transmitter.
- e. Reverse the preceding steps for reinstallation. Adjust transmitter in accordance with paragraph 7-16.

7-16. ADJUSTMENT.

- a. Run flaps to full UP position.
- b. Adjust position transmitter (12) in the slotted adjustment holes so that indicator reads 0°.
- c. If necessary, transmitter rod (14) may be bent slightly for additional adjustment.

7-17. CABLES AND PULLEYS. (Refer to figure 7-1.)

7-18. REMOVAL AND INSTALLATION.

- a. Remove access plates, fairings, headliner and upholstery as necessary for access.
- b. Remove safety wire, relieve cable tension, disconnect turnbuckles (6) and carefully lower LEFT flap.
- c. Disconnect cables at drive pulleys, remove cable guards and pulleys as necessary to work cables free of aircraft.

#### NOTE

To ease routing of cables, a length of wire may be attached to the end of cable being withdrawn from the aircraft. Leave wire in place, routed through structure; then attach the cable being installed and use wire to pull cable into position.

- d. Reverse the preceding steps for reinstallation.
- e. After cables are routed in position, install pulleys and cable guards. Ensure cables are positioned in pulley grooves before installing guards.
- f. Re-rig flap system in accordance with paragraph 7-19, safety turnbuckles and reinstall all items removed in step "a."

7-19. RIGGING.

- a. (Refer to figure 7-1.) Unzip or remove headliner as necessary for access to turnbuckles (6).
- b. Remove safety wire, relieve cable tension, disconnect turnbuckles (6) and carefully lower LEFT flap.
- c. (Refer to figure 7-2.) Disconnect push-pull rods (10) at drive pulleys (9) in both wings and lower RIGHT flap gently.
- d. Disconnect actuating tube (6) from drive pulley (9).

#### NOTE

If control cables are not connected to left and right drive pulleys, actuating tube (6) and push-pull rods (10) must be disconnected before installing cables. If drive pulleys (9) are not installed, attach control cables before installing drive pulleys in the wings as illustrated in figure 7-4.

- e. Connect position transmitter rod (14) to right drive pulley arm (16).
- f. Adjust both push-pull rods (10) to 8.83±.12 inches between centers of rod end bearings and tighten locknuts on both ends. Connect push-rods to flaps and drive pulleys.

#### NOTE

Temporarily connect cables at turnbuckles (index 6, figure 7-1) and test flaps by hand to ensure both flaps extend and retract together. If they will not, the cables are incorrectly attached to the drive pulleys. Ensure that the right drive pulley rotates clockwise, when viewed from below as the flaps are extended. Tag cables for reference and disconnect turnbuckles again.

- g. THRU AIRCRAFT SERIALS 17259904 AND F172-00804 WHEN NOT MODIFIED IN ACCORDANCE WITH SK150-37 AND WHEN NOT MODIFIED IN ACCORDANCE WITH FIGURE 7-2, SHEET 3. (Refer to figure 7-2, sheet 1.) Screw actuating tube (6) IN toward

NOTE

Bushings (4), rollers (3) and spacers (9) are first positioned through slots in flap tracks, then are secured to the flap roller supports (2) with attaching bolts, washers and nuts. Nylon plug buttons (11) prevent wing flap from chafing wing trailing edge.

Position spacers (9) and direction of bolts (5) as required to provide adequate flap clearance at wing root, flap well skin and aileron. Some lateral movement of flap is inherent due to the width of rollers. This movement should be considered when positioning spacers and direction of bolts.

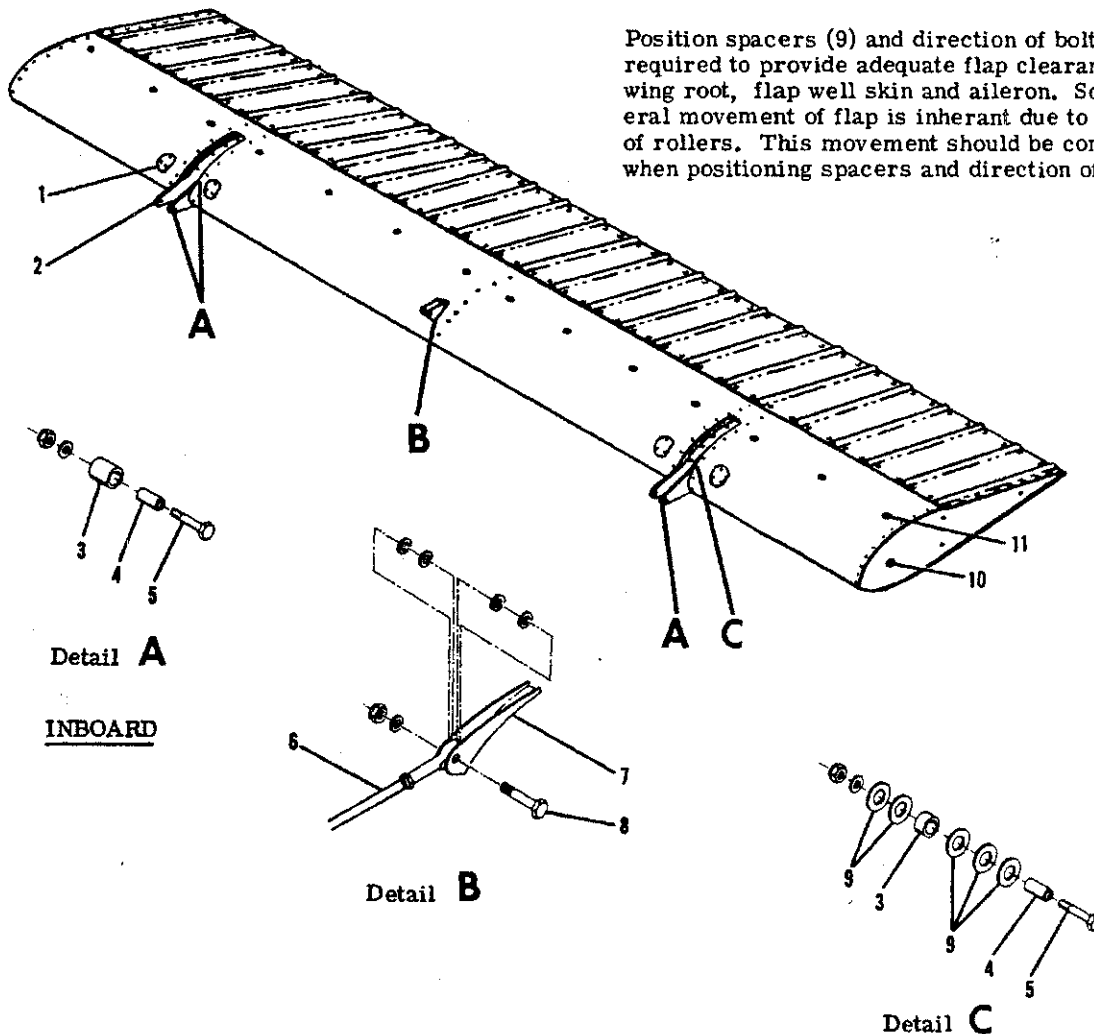

Detail A  
INBOARD

Detail B

Detail C  
OUTBOARD

1. Access Plate
2. Flap Support
3. Roller Assembly
4. Bushing
5. Bolt
6. Push-Pull Rod
7. Flap Bracket
8. Bolt
9. Spacer
10. Plug Button
11. Nylon Plug Button

Figure 7-3. Flap Installation

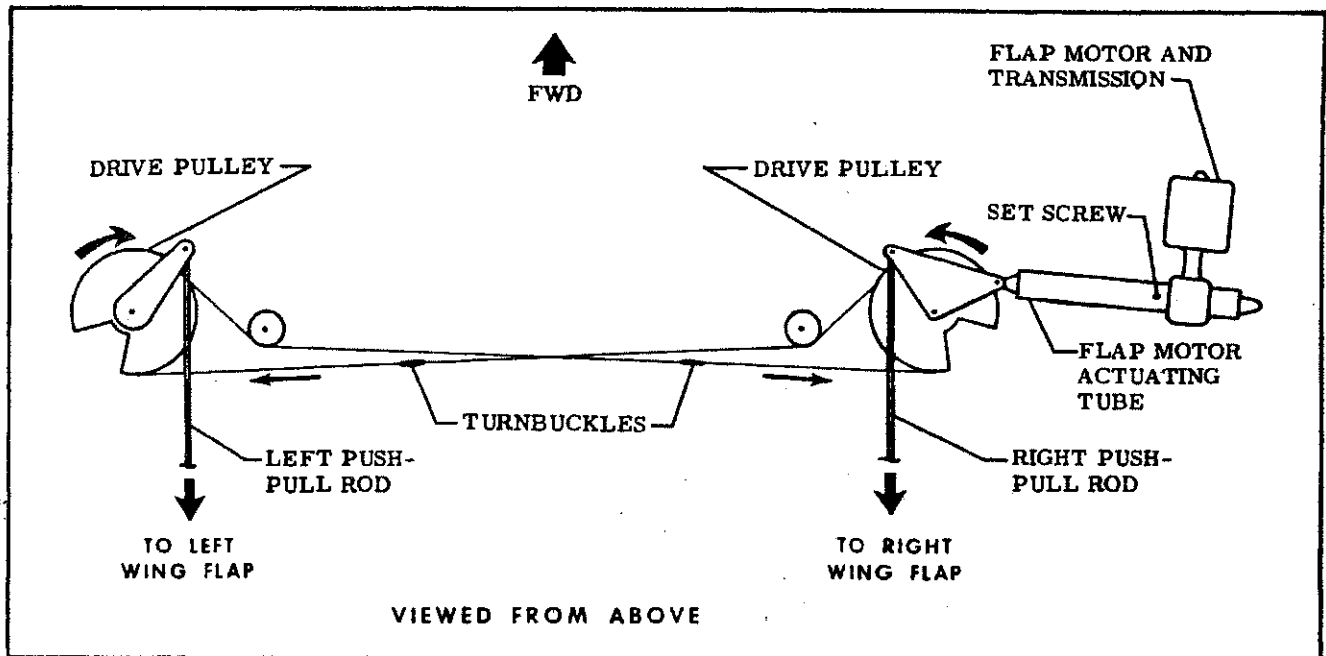

Figure 7-4. Flap System Schematic

transmission (4) by hand to its shortest length (flaps full up position). Loosen setscrew (19) securing actuating tube (6) to nut and ball assembly so that it will not move, hold RIGHT flap in the full UP position and adjust actuating tube (6) IN or OUT as necessary to align with attachment hole in drive pulley (9). Tighten setscrew (19) and secure tube to drive pulley with bolt (18).

h. THRU AIRCRAFT SERIALS 17259904 AND F172-00804 WHEN MODIFIED IN ACCORDANCE WITH SK-150-37 AND WHEN NOT MODIFIED IN ACCORDANCE WITH FIGURE 7-2, SHEET 3. (Refer to figure 7-2, sheet 2.) Operate flap motor until actuating tube (6) is IN to its shortest length (flaps full up position). Hold RIGHT flap in the full UP position and check actuating tube (6) to drive pulley (9) attachment holes for alignment. Operate flap motor toward the DOWN position until bolt (18) can be installed freely. Loosen setscrew (19) and rotate nut and ball assembly (20) IN against transmission (4). Tighten setscrew (19) and bolt (18).

i. BEGINNING WITH AIRCRAFT SERIALS 172-59905, F17200805 AND ALL AIRCRAFT MODIFIED IN ACCORDANCE WITH FIGURE 7-2, SHEET 3. (Refer to figure 7-2, sheets 2 and 3.) Screw actuating tube (6) IN toward transmission (4) by hand to .12±.05 inches between switch actuating collar (30) and transmission as illustrated in figure 7-2, VIEW A-A. Loosen setscrew (19) securing actuating tube (6) to switch actuating collar (30), hold actuating collar to maintain .12±.05", hole RIGHT flap in the full UP position and adjust actuating tube (6) IN or OUT as necessary to align with attachment hole in drive pulley (9). Tighten setscrew (19) in accordance with procedures outlined in the following note and secure actuating tube to drive pulley with bolt (18).

NOTE

Thru Aircraft Serials 17262444 and F1721225: Tighten setscrew (19). Aircraft Serials 17262445 thru 17263156 and F1721226 thru F1721234: Apply grade CV sealant to setscrew (19) threads and torque to 45 lb-in. Beginning with Aircraft Serials 17263157 and F1721235: Apply grade CV sealant to setscrew (19) threads and torque to 60 lb-in.

If actuating tube (6) is too long to allow attachment to drive pulley after completion of steps "g", "h" and "i", proceed to step "j."

j. Disconnect push-pull rod (10) at drive pulley (9), then connect actuating tube (6) to drive pulley.

k. Manually hold RIGHT flap in full UP position and readjust push-pull rod (10) to align with attachment hole in drive pulley. Connect push-pull rod and tighten locknuts or castellated nuts and install cotter pins.

NOTE

The right flap and actuator must be correctly rigged before cables and left flap can be rigged.

l. With flaps in full UP position, loosen setscrew (27) and slide up-limit switch adjustment block (28) on support (31) to operate switch (29) and shut-off electrical power to motor at this position. Tighten setscrew (27).

m. Manually hold LEFT flap full UP and connect control cables at turnbuckles (index 6, figure 7-1). Remove reference tags previously installed in step

"f" as turnbuckles are connected.

n. With flaps full UP, adjust turnbuckles to obtain 30±10 pounds tension on cables. Adjust retract cable first.

#### NOTE

Ensure cables are positioned in pulley grooves and cable ends are positioned correctly at drive pulleys before tightening turnbuckles.

o. Disconnect push-pull rod at left drive pulley. Run motor to extend flaps approximately 20° and check tension on each flap cable. If necessary, re-adjust turnbuckles to maintain 30±10 pounds tension on each cable and safety turnbuckles.

p. Fully retract right flap. Manually hold left flap in full up position and readjust push-pull rod to align with attaching hole in drive pulley. Connect push-pull rod and tighten locknuts or castellated nuts and install cotter pins.

#### NOTE

An inclinometer for measuring control surface travel is available from the Cessna Service Parts Center. Refer to figure 6-4.

q. Mount an inclinometer on one flap and adjust to 0°. Extend flaps and check down angle.

r. THRU AIRCRAFT SERIALS 17259904 AND F17200804 WHEN NOT MODIFIED IN ACCORDANCE WITH FIGURE 7-2, SHEET 3. After completion of steps "a" thru "q", the flap down angle should be as specified in figure 1-1. Repeat down angle check on opposite flap.

s. BEGINNING WITH AIRCRAFT SERIALS 172-59905, F17200805 AND ALL AIRCRAFT MODIFIED IN ACCORDANCE WITH FIGURE 7-2, SHEET 3. After completion of steps "a" through "q", adjust down-limit switch (32) to operate and shut-off electrical power to motor at degree of travel specified in figure 1-1. Repeat down angle check on opposite flap. Check operation of limit switches for positive shut-off through several cycles.

#### NOTE

Since the flap rollers may not bottom in the flap tracks with flaps fully extended, some free play may be noticed in this position.

t. With flaps full UP, adjust position transmitter (12) in accordance with paragraph 7-16.

u. Perform an operational check in accordance with paragraph 7-3, check all locknuts for tightness, all turnbuckles are saftied, cotter pins installed, and reinstall all items removed for access.



SECTION 8  
ELEVATOR CONTROL SYSTEM

TABLE OF CONTENTS	Page		
ELEVATOR CONTROL SYSTEM . . . . .	8-1	Forward . . . . .	8-6
Description . . . . .	8-1	Removal and Installation . . . . .	8-6
Trouble Shooting . . . . .	8-1	Rear . . . . .	8-6
Elevators . . . . .	8-2	Removal and Installation . . . . .	8-6
Removal and Installation . . . . .	8-2	Cables and Pulleys . . . . .	8-6
Repair . . . . .	8-6	Removal and Installation . . . . .	8-6
Bellcranks . . . . .	8-6	Rigging . . . . .	8-6

8-1. ELEVATOR CONTROL SYSTEM.

8-2. DESCRIPTION. The elevators are operated by power transmitted through forward and aft movement of the control "U". This power reaches the elevators through a system consisting of a push-pull tube, cables and bellcranks. The elevator control

cables, at their aft ends, are attached directly to a bellcrank, installed between the elevators. This bellcrank serves as an interconnect between the elevators and as a bearing point for the travel stop bolts. A trim tab is installed on the right elevator and is described in Section 9.

8-3. TROUBLE SHOOTING.

NOTE

Due to remedy procedures in the following trouble shooting chart it may be necessary to re-rig system, refer to paragraph 8-14.

TROUBLE	PROBABLE CAUSE	REMEDY
NO RESPONSE TO CONTROL WHEEL FORE-AND-AFT MOVEMENT.	Forward or aft end of push-pull tube disconnected.	Check visually and attach push-pull tube correctly.
	Cables disconnected.	Check visually, attach cables and rig system in accordance with paragraph 8-14.

8-3. TROUBLE SHOOTING (Cont).

TROUBLE	PROBABLE CAUSE	REMEDY
BINDING OR JUMPY MOTION FELT IN MOVEMENT OF ELEVATOR SYSTEM.	Defective forward or rear bellcrank or bellcrank pivot bearing.	Move to check for play or binding. Replace bellcranks found defective.
	Cables slack.	Check tension and adjust to tension specified in figure 8-1.
	Cables not riding correctly on pulleys.	Open access plates and observe pulleys. Route cables correctly over pulleys.
	Nylon bearing on instrument panel binding.	Disconnect universal joint and check for binding. Replace bearing if binding is felt.
	Defective control "U" pivot bearing.	Disconnect elevator push-pull tube at lower end of "U" and check that control moves freely. Replace bearing if defective.
	Defective elevator hinges.	Move elevators by hand, checking hinges. Replace hinges found defective.
	Lubrication needed.	Lubricate in accordance with Section 2.
	Clevis bolts too tight.	Check and readjust bolts to eliminate binding.
	Defective pulleys or cable guards.	Open access plates and check visually. Replace defective parts and install guards properly.
ELEVATORS FAIL TO ATTAIN PRESCRIBED TRAVEL.	Stops incorrectly set.	Check elevator travel with inclinometer. Rig in accordance with paragraph 8-14.
	Cables tightened unevenly.	Rig in accordance with paragraph 8-14.
	Interference at instrument panel.	Rig in accordance with paragraph 8-14.

8-4. ELEVATORS. (Refer to figure 8-2.)

b. Remove bolts (6) securing elevators to bellcrank (9).

8-5. REMOVAL AND INSTALLATION.

NOTE

This procedure is written primarily for the right elevator since the trim tab is attached to this elevator.

a. Disconnect trim tab push-pull channel (3) at tab actuator.

NOTE

If trim system is not moved and actuator screw is not turned, rigging of trim system should not be necessary after installation of elevator.

c. Remove bolts (11) from elevator hinges.  
d. Using care, remove elevator.



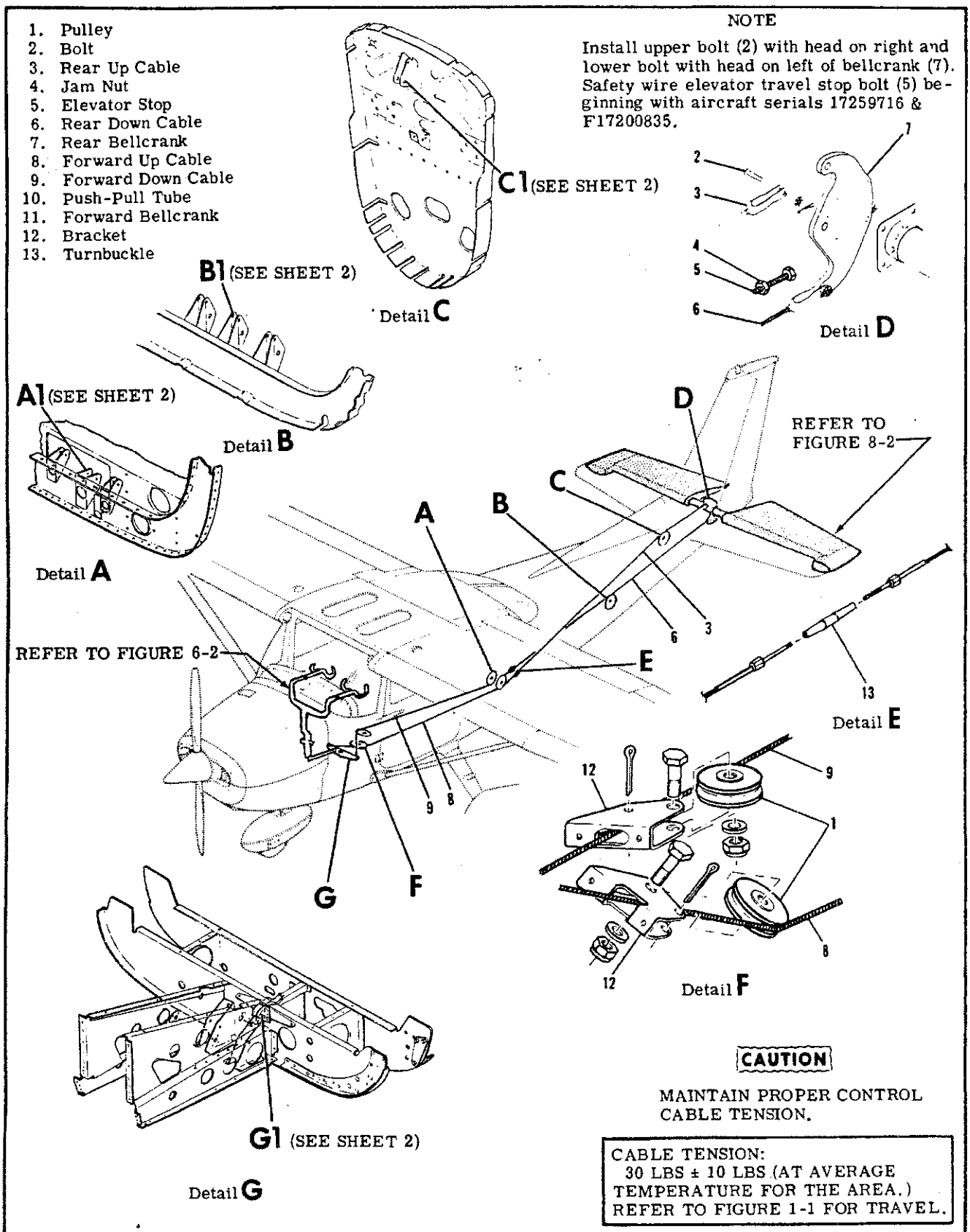
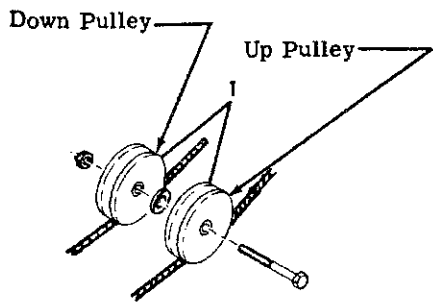
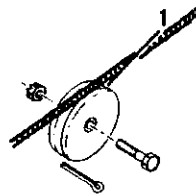

Figure 8-1. Elevator Control System (Sheet 1 of 2)



Detail **A1**



Detail **B1**  
(Down Pulley)

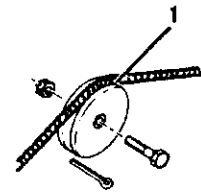

Detail **C1**  
(Up Pulley)

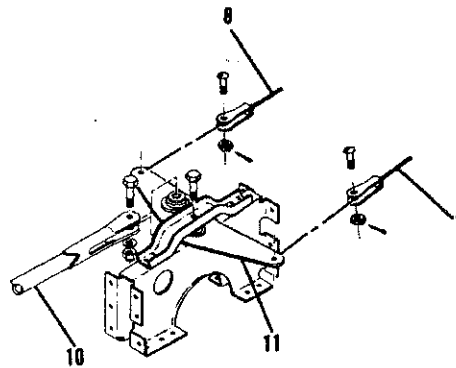

Detail **G1**

Figure 8-1. Elevator Control System (Sheet 2 of 2)

\*Castellated nuts and pins beginning with aircraft serials 17259107 and F172 00730

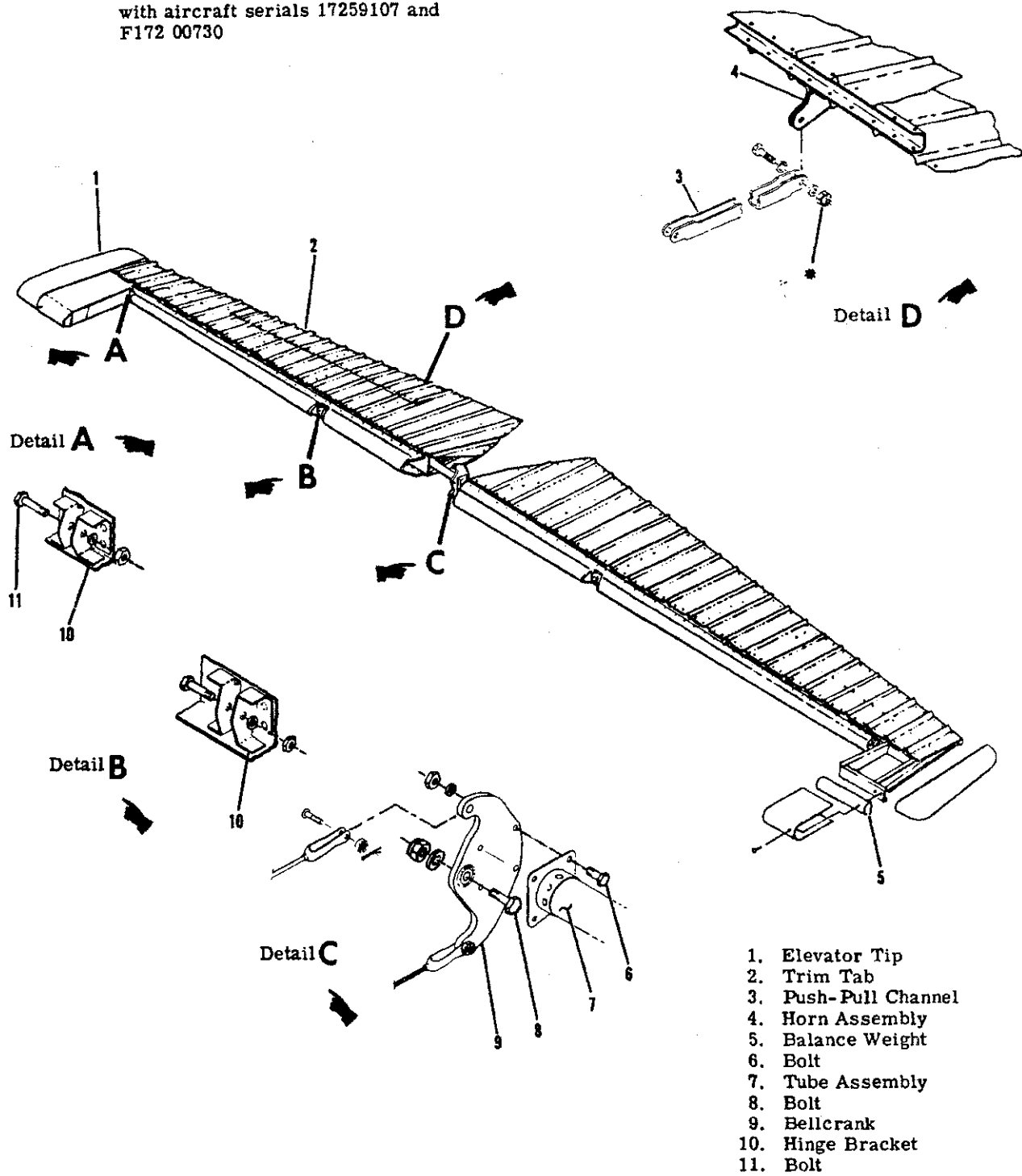

- 1. Elevator Tip
- 2. Trim Tab
- 3. Push-Pull Channel
- 4. Horn Assembly
- 5. Balance Weight
- 6. Bolt
- 7. Tube Assembly
- 8. Bolt
- 9. Bellcrank
- 10. Hinge Bracket
- 11. Bolt

Figure 8-2. Elevator Installation

e. To remove left elevator use same procedure, omitting step "a".

f. Reverse preceding steps for installation. Rig system in accordance with applicable paragraph in this section if necessary.

8-6. REPAIR. Repair may be accomplished as outlined in Section 18. If repair has affected static balance, check and rebalance as required.

8-7. BELLCRANKS.

8-8. FORWARD. (Refer to figure 8-1.)

8-9. REMOVAL AND INSTALLATION.

a. Remove seats, upholstery and access plates as necessary.

b. Relieve cable tension at turnbuckles (13) and disconnect cables from bellcrank (11).

c. Disconnect push-pull tube (10) from bellcrank (11).

d. Remove pivot bolt and remove bellcrank.

e. Reverse preceding steps for installation. Rig system in accordance with applicable paragraph in this section, safety turnbuckles and reinstall all items removed in step "a".

8-10. REAR. (Refer to figure 8-2.)

8-11. REMOVAL AND INSTALLATION.

a. Remove rudder. (Refer to Section 10.)

b. Relieve cable tension at turnbuckles (index 13, figure 8-1) and disconnect cables from rear bellcrank (9).

c. Remove bolts (6) securing elevators to bellcrank.

d. Remove bellcrank pivot bolt (8) and slide bellcrank from between tube assemblies (7).

#### NOTE

It may be necessary to remove one of the stabilizer attaching bolts for clearance when removing the bellcrank pivot bolt.

e. Reverse preceding steps for installation. Rig system in accordance with applicable paragraph in this section, safety turnbuckles and reinstall all items removed for access.

8-12. CABLES AND PULLEYS. (Refer to figure 8-1.)

8-13. REMOVAL AND INSTALLATION.

a. Remove seats, upholstery and access plates as necessary.

b. Relieve cable tension at turnbuckles (13).

c. Disconnect cables at forward bellcrank (11).

d. Disconnect cables at rear bellcrank (9).

e. Remove cable guards and pulleys as necessary to work cables free of aircraft.

#### NOTE

To ease routing of cables, a length of wire may be attached to end of cable before being withdrawn from aircraft. Leave wire in place, routed through structure, attach cable being installed and pull cable into position.

f. After cable is routed in position, install pulleys and cable guards. Ensure cable is positioned in pulley groove before installing guards.

g. Rig system in accordance with applicable paragraph in this section, safety turnbuckles and reinstall all items removed in step "a".

8-14. RIGGING. (Refer to figure 8-1.)

#### NOTE

An inclinometer for measuring control surface travel is available from Cessna Service Parts Center. Refer to figure 6-4.

a. Set travel stop bolts (5) to attain travel specified in Section 1.

#### NOTE

Travels shown are relative to horizontal stabilizer. Neutral position of elevators is where elevators are streamlined with stabilizer. Disregard counterweight areas of elevators when streamlining since these areas are contoured to streamline elevator tips in cruise flight.

b. Locate control yoke and elevators in neutral position by adjusting cable turnbuckles (13) equally to specified tension.

#### NOTE

Adjust turnbuckles (13) so control "U" does not contact instrument panel in the full "UP" position or firewall in full "DOWN" position.

c. Safety turnbuckles and install all parts removed for access.

### **WARNING**

Be sure elevators move in correct direction when operated by controls.

SECTION 9

ELEVATOR TRIM CONTROL SYSTEM

TABLE OF CONTENTS	Page		
ELEVATOR TRIM CONTROL SYSTEM . . . . .	9-1	Reassembly . . . . .	9-6
Description . . . . .	9-1	Trim Tab Free-Play Inspection . . . . .	9-6
Trouble Shooting . . . . .	9-1	Trim Tab Control Wheel . . . . .	9-6
Trim Tab . . . . .	9-2	Removal and Installation . . . . .	9-6
Removal and Installation . . . . .	9-2	Cables and Pulleys . . . . .	9-7
Trim Tab Actuator . . . . .	9-2	Removal and Installation . . . . .	9-7
Removal and Installation . . . . .	9-2	Pedestal Cover . . . . .	9-7
Disassembly . . . . .	9-2	Removal and Installation . . . . .	9-7
Cleaning, Inspection and Repair . . . . .	9-6	Rigging . . . . .	9-7

9-1. ELEVATOR TRIM CONTROL SYSTEM. (Refer to figure 9-1.)

9-2. DESCRIPTION. The elevator trim tab, located on the right elevator, is controlled by a trim wheel mounted in the pedestal. Power to operate

the tab is transmitted from the trim control wheel by means of chains, cables and an actuator. A mechanical pointer, adjacent to the trim wheel indicates tab position. A "nose-up" setting results in a tab-down position.

9-3. TROUBLE SHOOTING.

NOTE

Due to remedy procedures in the following trouble shooting chart it may be necessary to re-rig system, refer to paragraph 9-14.

TROUBLE	PROBABLE CAUSE	REMEDY
TRIM CONTROL WHEEL MOVES WITH EXCESSIVE RESISTANCE.	Cable tension too high.	Check and adjust tension as specified in figure 9-1.
	Pulleys binding or rubbing.	Open access plates and check visually. Repair or replace as necessary.
	Cables not in place on pulleys.	Open access plates and check visually. Install cables correctly.
	Trim tab hinge binding.	Disconnect actuator and move tab to check resistance. Lubricate or replace hinge as necessary.
	Defective trim tab actuator.	Remove chain from actuator sprocket and operate actuator manually. Replace actuator if defective.
	Rusty chain.	Check visually. Replace chain.
	Damaged sprocket.	Check visually. Replace sprockets.
	Bent sprocket shaft.	Observe motion of sprockets. Replace bent sprocket shafts.

9-3. TROUBLE SHOOTING (Cont).

TROUBLE	PROBABLE CAUSE	REMEDY
LOST MOTION BETWEEN CONTROL WHEEL AND TRIM TAB.	Cable tension too low.	Check and adjust tension as specified in figure 9-1.
	Broken pulley.	Open access plates and check visually. Replace defective pulley.
	Cable not in place on pulleys.	Open access plates and check visually. Install cables correctly.
	Worn trim tab actuator.	Remove and replace worn actuator.
	Actuator attachment loose.	Check actuator for security. Tighten as necessary.
TRIM INDICATOR FAILS TO INDICATE CORRECT TRIM POSITION.	Indicator incorrectly engaged on wheel track.	Check visually and reset indicator as necessary.
INCORRECT TRIM TAB TRAVEL.	Stop blocks loose or incorrectly adjusted.	Adjust stop blocks on cables. Refer to figure 9-2.

9-4. TRIM TAB. (Refer to figure 8-2.)

9-5. REMOVAL AND INSTALLATION.

- a. Disconnect push-pull channel (3) from horn assembly (4).
- b. Drill out rivets attaching hinge to elevator.

**NOTE**

After tab has been removed and if hinge pin is to be removed, it is necessary to spread the crimped ends of the hinge before driving out pin. When a pin has been installed, crimp ends of hinge to prevent pin from working out.

- c. Reverse preceding steps for installation.

9-6. TRIM TAB ACTUATOR.

9-7. REMOVAL AND INSTALLATION. (Refer to figure 9-1.)

**CAUTION**

Position a support stand under tail tie-down ring to prevent tailcone from dropping while working inside.

- a. Remove baggage compartment aft wall for access.
- b. Remove safety wire and relieve cable tension at turnbuckle (8).

- c. Disconnect push-pull tube from actuator (3).
- d. Remove access plate from underside of right hand stabilizer beneath actuator.
- e. Remove chain guard (2) and disengage chain (4) from actuator sprocket.
- f. Remove screws attaching actuator clamps to bracket and carefully work actuator out through access opening.
- g. Reverse the preceding steps for reinstallation. Rig trim system in accordance with paragraph 9-14, safety turnbuckle (8) and reinstall all items removed for access.

9-7A. DISASSEMBLY. (Refer to figure 9-3.)

- a. Remove actuator in accordance with paragraph 9-7.
- b. Disassemble actuator assembly (1) as illustrated in Detail A as follows:
  1. Remove chain guard (3) if not previously removed in step "e" of paragraph 9-7.
  2. Using suitable punch and hammer, remove groov-pins (8) securing sprocket (5) to screw (9) and remove sprocket from screw.
  3. Unscrew threaded rod end (15) and remove rod end from actuator.
  4. Remove groov-pins (10) securing bearings (6 and 14) at the housing ends.
  5. Lightly tap screw (9) toward the sprocket end of housing, remove bearing (6) and collar (7).
  6. Lightly tap screw (9) in the opposite direction from sprocket end, remove bearing (14), O-ring (13) and collar (7).
  7. It is not necessary to remove retaining rings (11).

1. Pulley (Sheet 2)
2. Chain Guard
3. Actuator
4. Aft Chain
5. Left Aft Cable
6. Left Forward Cable
7. Right Aft Cable
8. Turnbuckle
9. Right Forward Cable
10. Stop Block
11. Bushing
12. Rear Chain
13. Forward Chain
14. Trim Wheel- 15. Sprocket
- 16. Pointer
- 17. Retainer
- 18. Pedestal
- 19. Roll Pin

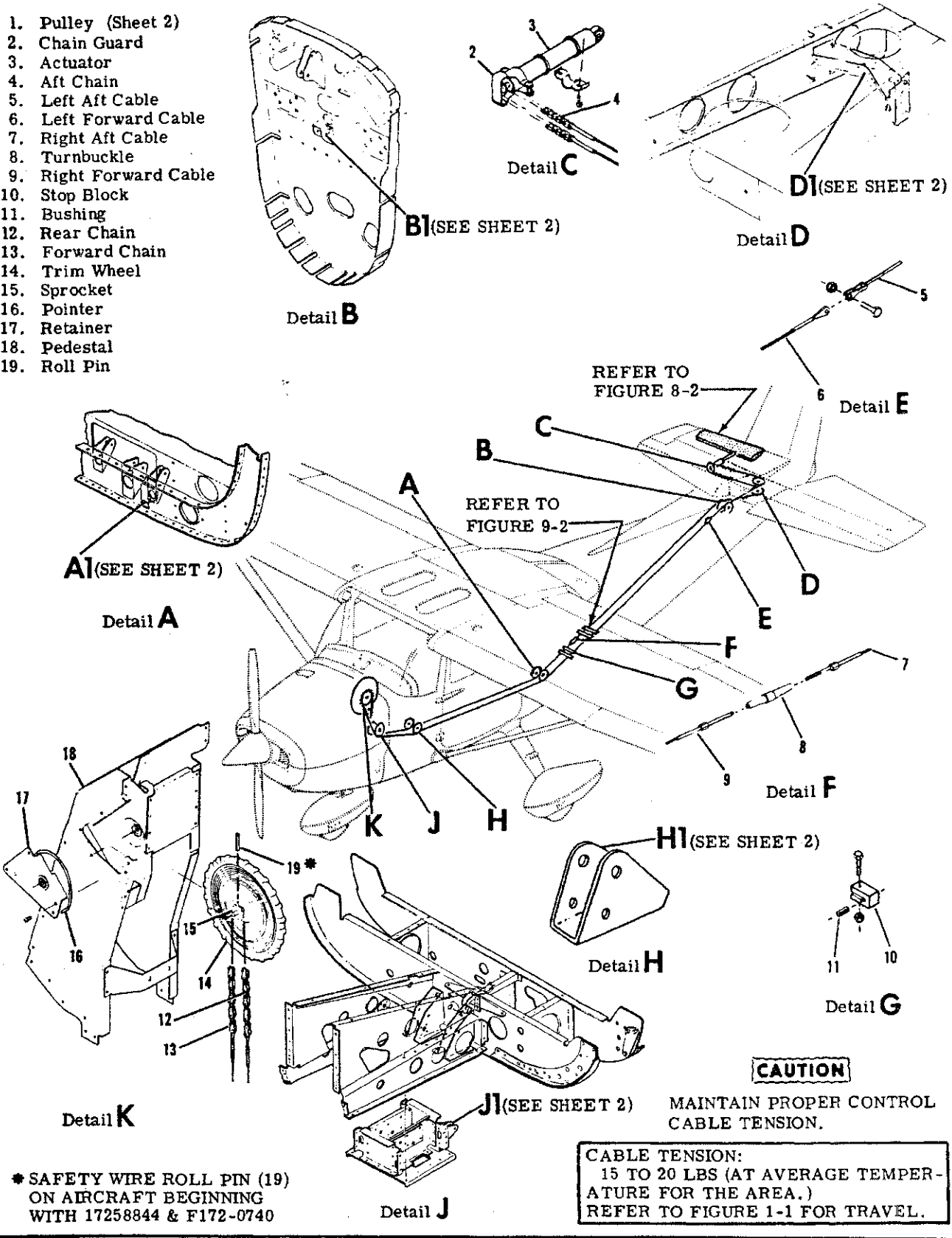

\* SAFETY WIRE ROLL PIN (19)  
ON AIRCRAFT BEGINNING  
WITH 17258844 & F172-0740

Figure 9-1. Elevator Trim Tab Control System (Sheet 1 of 2)

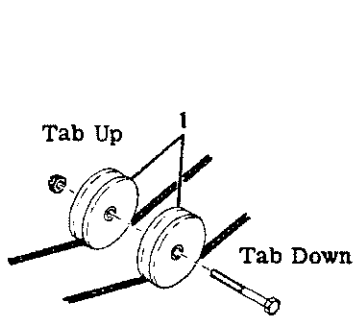

Detail **A1**

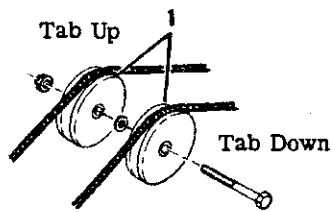

Detail **B1**

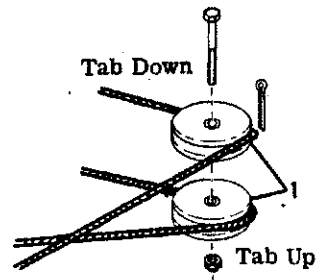

Detail **D1**

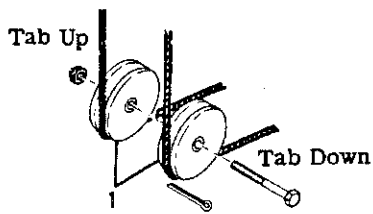

Detail **J1**

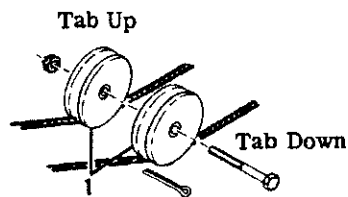

Detail **H1**

Figure 9-1. Elevator Trim Tab Control System (Sheet 2 of 2)





### 9-7B. CLEANING, INSPECTION AND REPAIR.

(Refer to figure 9-3.)

- a. DO NOT remove bearing (16) from threaded rod end (15) unless replacement of bearing is necessary.
- b. Clean all component parts, except bearing (16), by washing in Stoddard solvent or equivalent. Do not clean sealed bearing (16).
- c. Inspect all component parts for obvious indications of damage such as stripped threads, cracks, deep nicks and dents.
- d. Check bearings (6 and 14), screw (9) and threaded rod end (15) for excessive wear and scoring.

Dimensions of the parts are as follows:

BEARING (6)	
INSIDE DIAMETER	0.373" MIN.
INSIDE DIAMETER	0.380" MAX.
BEARING (14)	
INSIDE DIAMETER	
SMALL HOLE	0.248" MIN.
SMALL HOLE	0.253" MAX.
LARGE HOLE	0.373" MIN.
LARGE HOLE	0.380" MAX.
THREADED ROD END (15)	
OUTSIDE DIAMETER	
(SHANK)	0.242" MIN.
	0.246" MAX.
SCREW (9)	
OUTSIDE DIAMETER	0.367" MIN.
	0.370" MAX.

#### NOTE

Relative linear movement between internal threaded screw (9) and bearing (14) should be 0.004 to 0.010 inch at room temperature.

- e. Examine threaded rod end (15) and screw (9) for damaged threads or dirt particles that may impair smooth operation.
- f. Check sprocket (5) for broken, chipped and/or worn teeth.
- g. Check bearing (16) for smoothness of operation.
- h. DO NOT attempt to repair damaged or worn parts of the actuator assembly. Discard all defective items and install new parts during reassembly.

### 9-7C. REASSEMBLY. (Refer to figure 9-3.)

- a. Always discard the following items and install new parts during reassembly:
  1. Groov-Pins (8 and 10).
  2. O-Ring (13).
  3. Nuts (2).
- b. During reassembly, lubricate collars (7), screw (9) and threaded rod end (15) in accordance with procedures outlined in Section 2.
- c. Install collar (7) and bearing (6) on screw (9).
- d. Press sprocket (5) into the end of screw (9), align groov-pin holes and install new groov-pins (8).
- e. Insert screw (9), with assembled parts, into housing (12) until bearing (6) is flush with end of housing.

#### NOTE

When inserting screw (9) into housing (12), locate the sprocket (5) at the end of housing which is farther away from the groove for retaining ring (11).

- The bearings (6 and 14) are not pre-drilled and must be drilled on assembly. The groov-pins (10) are 1/16 inch in diameter, therefore, requiring a 1/16 (0.0625) inch drill.

- f. With bearing (6) flush with end of housing (12), carefully drill bearing so the drill will emerge from the hole on the opposite side of housing (12). DO NOT ENLARGE HOLES IN HOUSING.
- g. Press new groov-pins (10) into pin holes.
- h. Insert collar (7), new O-ring (13) and bearing (14) into opposite end of housing (12).
- i. Complete steps "f" and "g" for bearing (14).
- j. If a new bearing (16) is required, a new bearing may be pressed into the boss. Be sure force bears against the outer race of bearing.
- k. Screw the threaded rod end (15) into screw (9).
- l. Install retaining rings (11), if they were removed.
- m. Test actuator assembly by rotating sprocket (5) with fingers while holding threaded rod end (15). The threaded rod end should travel in and out smoothly, with no indication of binding.
- n. Reinstall actuator assembly in accordance with paragraph 9-7.

### 9-7D. TRIM TAB FREE-PLAY INSPECTION.

- a. Place elevators and trim tab in the neutral position.
- b. Using moderate pressure, move the trim tab trailing edge up and down by hand to check free-play.
- c. A maximum of .131" (total motion up and down) measured at the trim tab trailing edge is permissible.
- d. If the trim tab free-play is less than .131", the system is within prescribed limits.
- e. If the trim tab free-play is more than .131", check the following items for looseness while moving the trim tab up and down.
  1. Check push-pull channel to trim tab horn assembly attachment for looseness.
  2. Check push-pull channel to actuator assembly threaded rod end attachment for looseness.
  3. Check actuator assembly threaded rod end for looseness in the actuator assembly.
- f. If looseness is apparent while checking steps e-1 and e-2, repair by installing new parts.
- g. If looseness is apparent while checking step e-3, refer to paragraphs 9-6 through 9-7C.

### 9-8. TRIM TAB CONTROL WHEEL. (Refer to figure 9-1.)

### 9-9. REMOVAL AND INSTALLATION.

- a. Relieve cable tension at turnbuckle (8).

#### CAUTION

Position a support stand under tail tie-down ring to prevent tailcone from dropping while working inside.

- b. Remove pedestal cover (12). (Refer to applicable paragraph in this section.)
- c. Remove screws attaching control wheel retainer (17).
- d. Remove retainer and pointer (16), using care not to drop control wheel (14).
- e. Disengage roller chain (13) from sprocket (15) and remove control wheel.
- f. Reverse preceding steps for installation. Rig system in accordance with applicable paragraph in this section, safety turnbuckle and reinstall all items removed for access.

9-10. CABLES AND PULLEYS. (Refer to figure 9-1.)

9-11. REMOVAL AND INSTALLATION.

- a. Remove seats, upholstery and access plates as necessary.
- b. Disconnect cables at turnbuckle (8) and cable ends (5 and 6).
- c. Remove cable guards and pulleys as necessary to work cables free of aircraft.

**NOTE**

To ease routing of cables, a length of wire may be attached to end of cable before being withdrawn from aircraft. Leave wire in place, routed through structure, attach cable being installed and pull cable into position.

- d. After cable is routed in position, install pulleys and cable guards. Ensure cable is positioned in pulley groove before installing guards.
- e. Rig system in accordance with applicable paragraph in this section, safety turnbuckle and reinstall all items removed in step "a."

9-12. PEDESTAL COVER. (Refer to figure 9-1.)

9-13. REMOVAL AND INSTALLATION.

- a. Remove fuel selector valve handle and placard.
- b. Remove mike and remove mike jack mounting nut.
- c. Remove screws attaching pedestal cover to structure and remove cover.

9-14. RIGGING. (Refer to figure 9-1.)

**CAUTION**

Position a support stand under tail tie-down ring to prevent tailcone from dropping while working inside.

- a. Remove rear baggage compartment panel and access plates as necessary.
- b. Loosen travel stop blocks (10) on cables.
- c. Disconnect actuator (3) from trim tab push-pull channel.

- d. Check cable tension and readjust turnbuckle (8) if necessary.

**NOTE**

If chains and/or cables are being installed, permit actuator screw to rotate freely as chains and cables are connected. Set cable tension.

- e. Rotate trim wheel (14) full forward (nose down). Ensure pointer (16) does not restrict wheel movement. If necessary, reposition pointer using a thin screwdriver to pry trailing leg of pointer out of groove.

**NOTE**

Full forward (nose down) position of trim wheel is where further movement is prevented by chain or cable ends contacting sprockets or pulleys.

- f. With elevator and trim tab both in neutral (streamlined), place inclinometer on tab and set to zero.

**NOTE**

An inclinometer for measuring control surface travel is available from Cessna Service Parts Center. Refer to figure 6-4.

- g. Rotate actuator screw in or out as required to place tab up with a maximum of 2° overtravel, with actuator screw connected to push-pull channel.
- h. Rotate trim wheel to position tab up and down, readjusting actuator screw as required to obtain overtravel in both directions.
- i. Position stop blocks (10) and adjust as illustrated in figure 9-2 to limit travel as outlined in Section 1.
- j. Check trim wheel pointer travels the same distance from ends of slot in cover. Reposition trailing leg of pointer if necessary (refer to step "d").
- k. Safety turnbuckle and reinstall all items removed in step "a".

**WARNING**

Be sure trim tab moves in correct direction when operated by trim wheel. Nose down trim corresponds to tab up position.



SECTION 10  
 RUDDER CONTROL SYSTEM

TABLE OF CONTENTS	Page		
RUDDER CONTROL SYSTEM . . . . .	10-1	Removal and Installation . . . . .	10-7
Description . . . . .	10-1	Repair . . . . .	10-7
Trouble Shooting . . . . .	10-1	Cables and Pulleys . . . . .	10-7
Rudder Pedal Assembly . . . . .	10-2	Removal and Installation . . . . .	10-7
Removal and Installation . . . . .	10-2	Rigging . . . . .	10-8
Rudder . . . . .	10-7		

10-1. RUDDER CONTROL SYSTEM. (Refer to figure 10-1.)

10-2. DESCRIPTION. Rudder control is maintained through use of conventional rudder pedals which also control nose wheel steering. The system is com-

prised of rudder pedals, cables and pulleys, all of which link the pedals to the rudder and nose wheel steering. Cable tension is automatically determined when the rudder pedals are rigged against return springs 6.50 inches from firewall.

10-3. TROUBLE SHOOTING.

NOTE

Due to remedy procedures in the following trouble shooting chart it may be necessary to re-rig system, refer to paragraph 10-11.

TROUBLE	PROBABLE CAUSE	REMEDY
RUDDER DOES NOT RESPOND TO PEDAL MOVEMENT.	Broken or disconnected cables.	Open access plates and check visually. Connect or replace cables.

10-3. TROUBLE SHOOTING (Cont).

TROUBLE	PROBABLE CAUSE	REMEDY
BINDING OR JUMPY MOVEMENT OF RUDDER PEDALS.	Cables too tight.	Refer to figure 10-2 for distance between firewall and pedals. Rig system in accordance with paragraph 10-11.
	Cables not riding properly on pulleys.	Open access plates and check visually. Route cables correctly over pulleys.
	Binding, broken or defective pulleys or cable guards.	Open access plates and check visually. Replace defective pulleys and install guards properly.
	Pedal bars need lubrication.	Refer to Section 2.
	Defective rudder bar bearings.	If lubrication fails to eliminate binding. Replace bearing blocks.
	Defective rudder hinge bushings.	Check visually. Replace defective bushings.
	Clevis bolts too tight.	Check and readjust bolts to eliminate binding.
LOST MOTION BETWEEN RUDDER PEDALS AND RUDDER.	Steering rods improperly adjusted.	Rig system in accordance with paragraph 10-11.
	Insufficient cable tension.	Refer to figure 10-2 for distance between firewall and pedals. Rig system in accordance with paragraph 10-11.
INCORRECT RUDDER TRAVEL.	Incorrect rigging.	Rig in accordance with paragraph 10-11.

10-4. RUDDER PEDAL ASSEMBLY. (Refer to figure 10-2.)

10-5. REMOVAL AND INSTALLATION.

- a. Remove carpeting, shields and soundproofing from pedal and tunnel areas as necessary.
- b. Disconnect master cylinders (12) at pilot rudder pedals.
- c. Disconnect parking brake cables at master cylinders.
- d. Remove rudder pedals (2) and brake links (5).
- e. Thru Aircraft Serial 17263809 and F17201324, relieve cable tension at turnbuckles (index 6, figure 10-1); beginning with Aircraft Serial 17263810 and F17201325, relieve cable tension at clevises (index 11, figure 10-1).
- f. Disconnect cables, return springs and steering tubes from rudder bars.

- g. Remove bolts securing bearing blocks (8) and work rudder bars out of tunnel area.

NOTE

Rudder bar assemblies should be checked for excessive wear before installation. The bearing blocks are nylon and require no lubrication unless binding occurs. A few drops of general purpose oil should eliminate such binding.

- h. Reverse preceding steps for installation. Rig system in accordance with applicable paragraph in this section. Safety turnbuckles or clevises, as applicable, and reinstall all items removed in step "a".

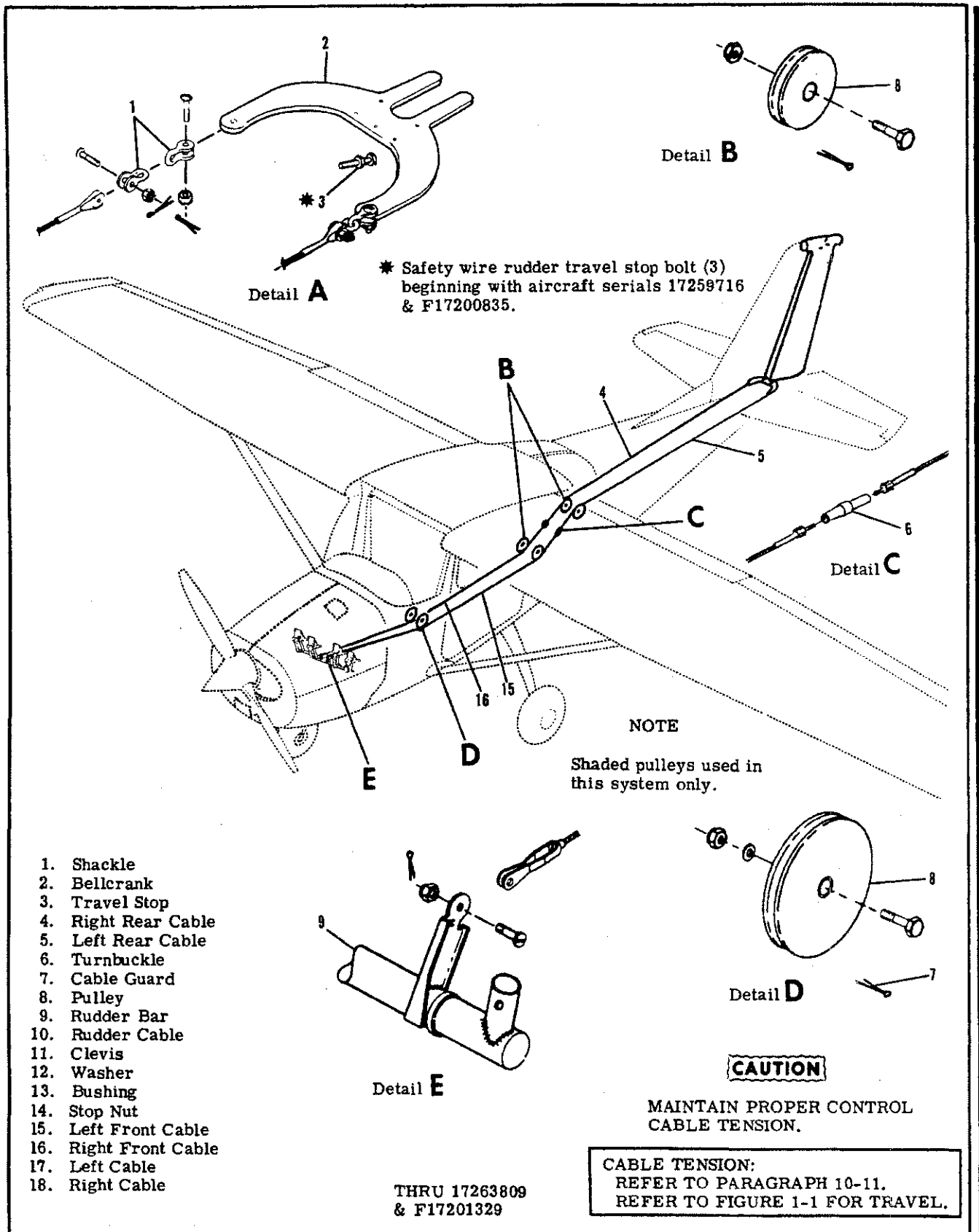

1. Shackle
2. Bellcrank
3. Travel Stop
4. Right Rear Cable
5. Left Rear Cable
6. Turnbuckle
7. Cable Guard
8. Pulley
9. Rudder Bar
10. Rudder Cable
11. Clevis
12. Washer
13. Bushing
14. Stop Nut
15. Left Front Cable
16. Right Front Cable
17. Left Cable
18. Right Cable

Figure 10-1. Rudder Control System (Sheet 1 of 2)

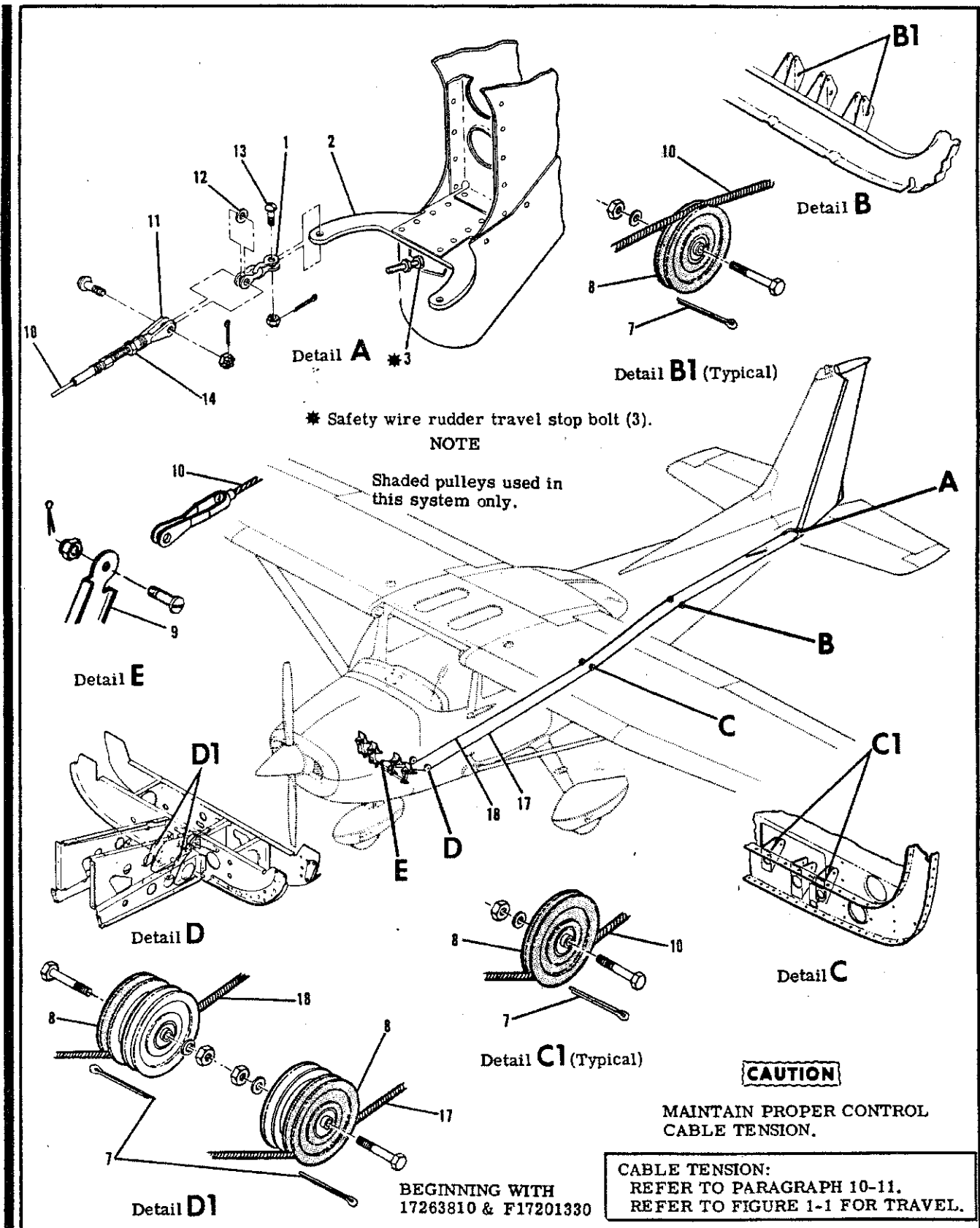

Figure 10-1. Rudder Control System (Sheet 2 of 2)



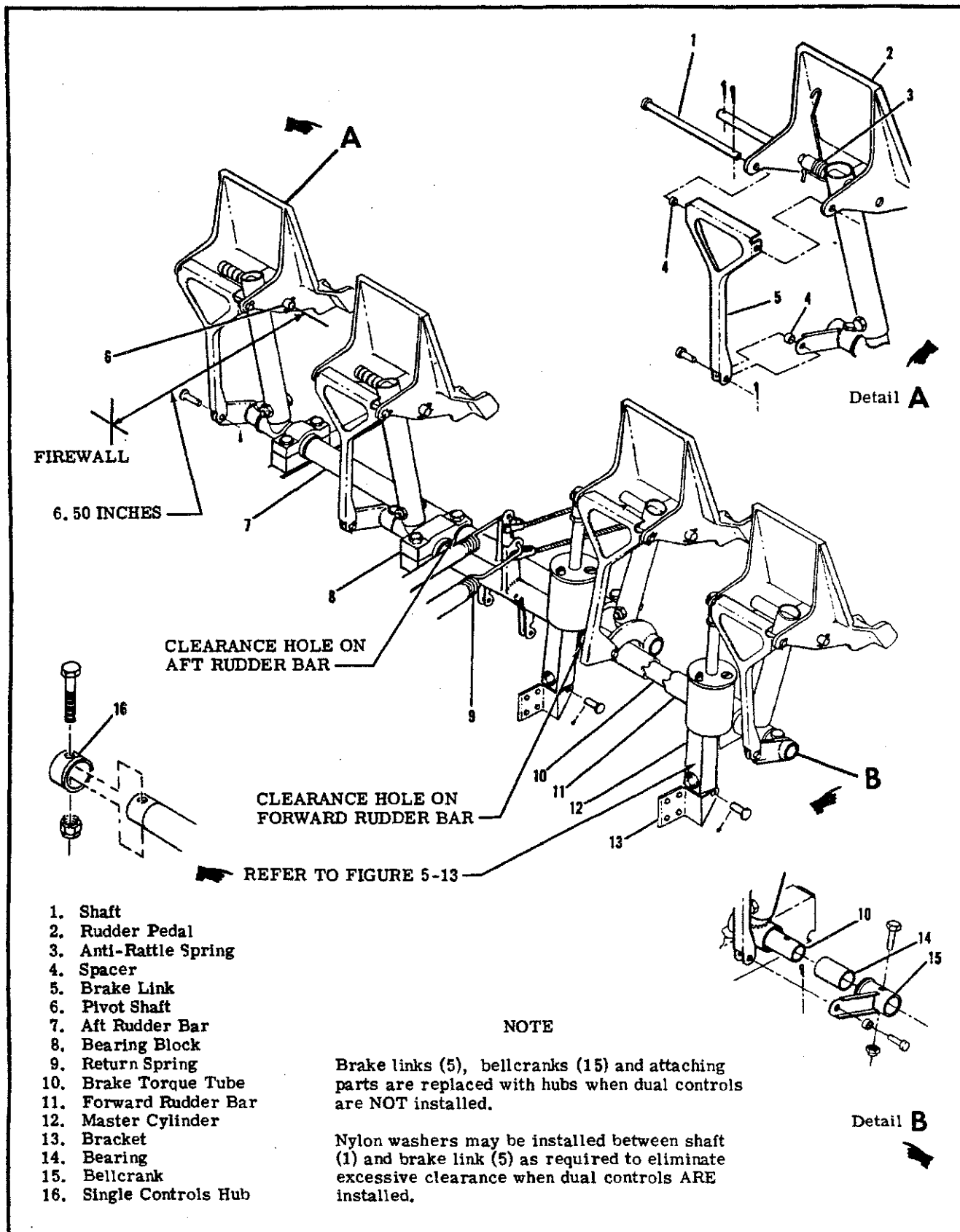

Figure 10-2. Rudder Pedals Installation

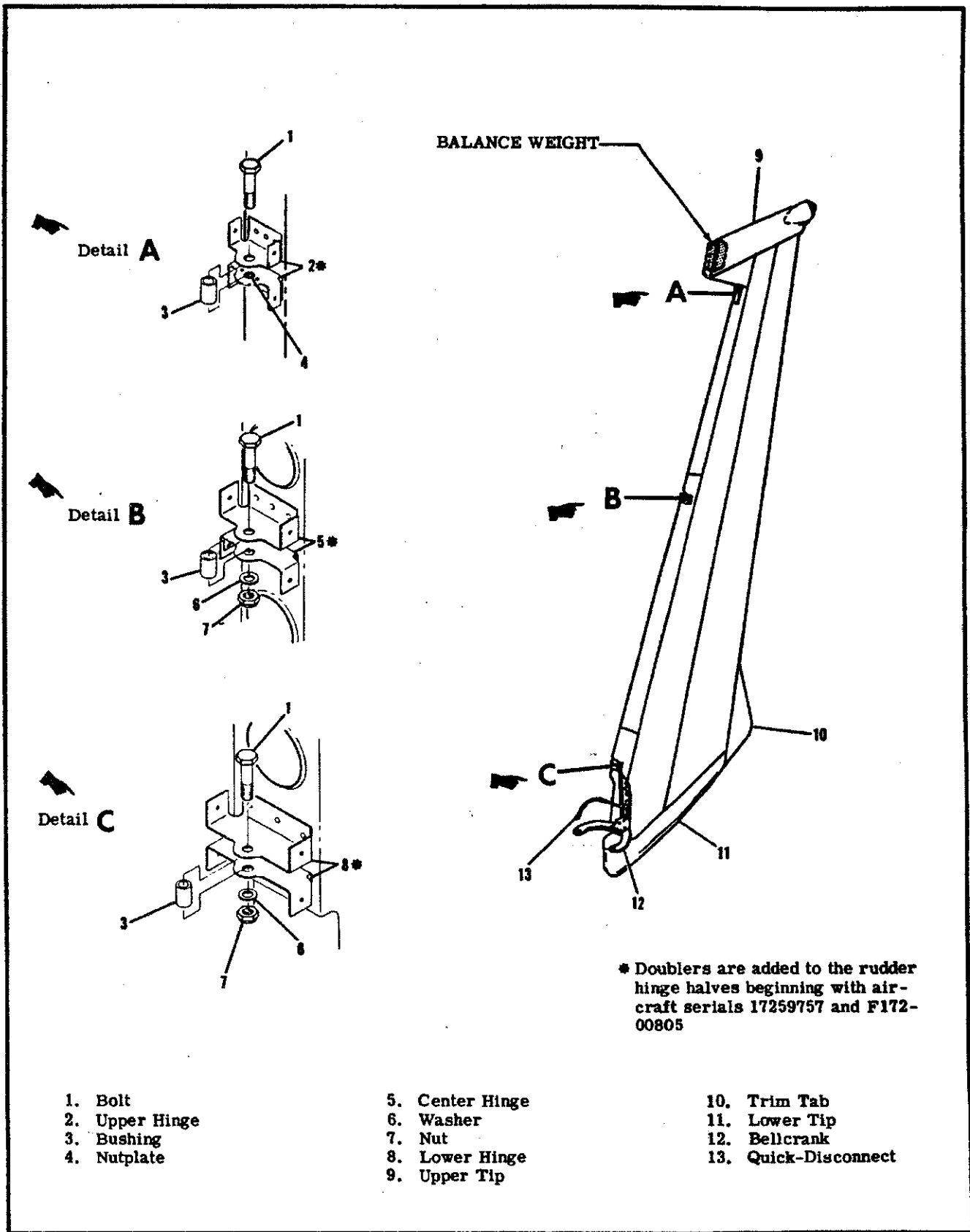

Figure 10-3. Rudder Assembly

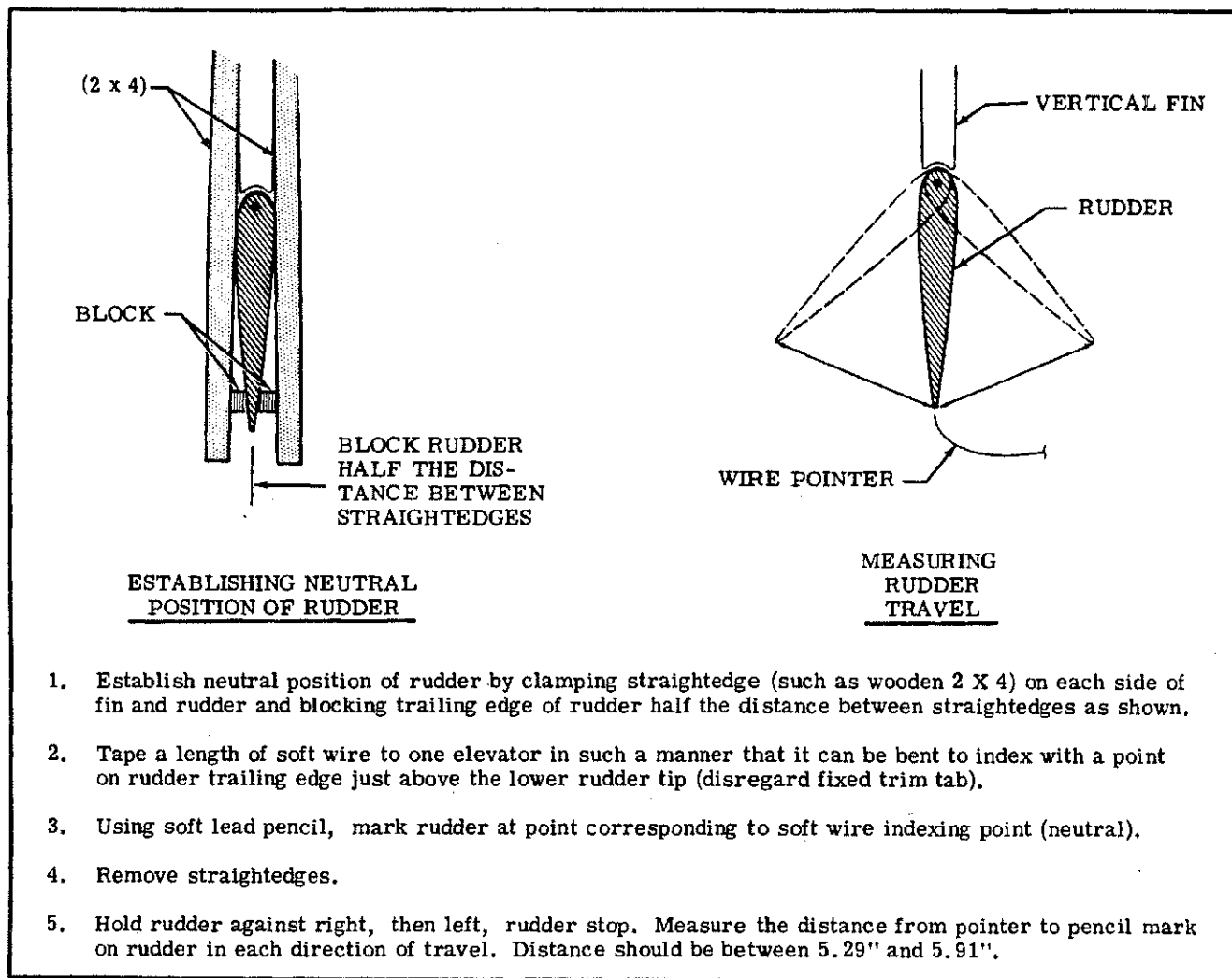

Figure 10-4. Checking Rudder Travel

10-6. RUDDER. (Refer to figure 10-3.)

10-7. REMOVAL AND INSTALLATION.

a. Disconnect tail navigation light quick-disconnect (13).

b. Thru Aircraft Serial 17263809 and F17201324, relieve cable tension at turnbuckles (index 6, figure 10-1) and disconnect cables from rudder bellcrank (12). Beginning with Aircraft Serial 17263810 and F17201325, relieve cable tension at clevises (index 11, figure 10-1) and disconnect clevises from rudder bellcrank (12).

c. With rudder supported, remove hinge bolts (1) and lift rudder free of vertical fin.

d. Reverse preceding steps for installation. Rig system in accordance with appropriate paragraph in this section and safety turnbuckles or clevises, as applicable.

10-8. REPAIR. Repair may be accomplished as outlined in Section 18. Hinge bushings may be replaced as necessary.

10-9. CABLES AND PULLEYS. (Refer to figure 10-1.)

10-10. REMOVAL AND INSTALLATION.

a. Remove seats, upholstery and access plates as necessary.

b. Disconnect cable at rudder bar (9) and bellcrank (2).

c. Remove cable guards and pulleys as necessary to work cables free of aircraft.

**NOTE**

To ease routing of cables, a length of wire may be attached to end of cable before being withdrawn from aircraft. Leave wire in place, routed through structure, attach cable being installed and pull cable into position.

d. After cable is routed in position, install pulleys and cable guards. Ensure cable is positioned in pulley groove before installing guard.

e. Rig system in accordance with appropriate paragraph in this section. Safety turnbuckles or clevises, as applicable, and reinstall all items removed in step "a".

10-11. RIGGING. (Refer to figure 10-1.)

a. Adjust travel stops (3) to attain travel specified in Section 1. Figure 10-4 illustrates correct travel and one method of checking.

b. Disconnect nose wheel steering tubes (refer to figure 5-5) from nose strut.

c. Thru Aircraft Serial 17263809 and F17201324, adjust cables at turnbuckles (6); beginning with Aircraft Serial 17263810 and F17201325, adjust cables at clevises (11) to align rudder and pedals in neutral position, 6.50 inches from firewall and pedal pivot shafts (index 6, figure 10-2). This step automatically determines cable tension through use of return springs (index 9, figure 10-2).

**NOTE**

Due to thickness of insulation on firewall, it is recommended that a piece of 1/16 inch welding rod be ground to a sharp point and notched at the 6.50 inch dimension. Pierce insulation on firewall and use notch to measure proper dimension.

d. Tie down or weight tail to raise nose wheel free of ground.

e. Center nose gear against external stop.

f. Extend steering tubes until free play is removed. **DO NOT COMPRESS SPRINGS.**

g. Adjust steering tube rod ends to 1.00 inch dimension between steering arm assembly and bolt

hole as illustrated in figure 5-8 and tighten jam nuts.  
h. Adjust steering tube clevises to align with rod end bearings.

**NOTE**

Extend steering tubes to seat rods against internal springs but do not attempt to preload these springs by shortening rod end clevises after alignment. Preload is built into steering tubes.

i. Install clevises on rod ends.

**NOTE**

**DO NOT** adjust rudder trim with steering tubes. Degree of steering travel cannot be adjusted.

j. Safety cable turnbuckles or clevises, as applicable, and install all items removed for access.

**NOTE**

Flight test aircraft to determine if ground adjustment of fixed trim tab is necessary. **DO NOT** rig rudder "off-center" unless trim tab does not provide adequate correction.

**WARNING**

Be sure rudder moves in correct direction when operated by pedals.

SECTION 11

ENGINE  
(LYCOMING "BLUE STREAK")

TABLE OF CONTENTS		Page		Page
ENGINE COWLING . . . . .	11-1		Description . . . . .	11-16
Description . . . . .	11-1		Carburetor . . . . .	11-16
Removal and Installation . . . . .	11-1		Removal and Installation . . . . .	11-16
Cleaning and Inspection . . . . .	11-2		Idle Speed and Mixture	
Repair . . . . .	11-2		Adjustments . . . . .	11-16
ENGINE . . . . .	11-2		Induction Air System . . . . .	11-17
Description . . . . .	11-2		Description . . . . .	11-17
Engine Data . . . . .	11-3		Removal and Installation . . . . .	11-17
Trouble Shooting . . . . .	11-4		Ignition System . . . . .	11-17
Removal . . . . .	11-6		Description . . . . .	11-17
Cleaning . . . . .	11-7		Trouble Shooting . . . . .	11-18
Accessories Removal . . . . .	11-7		Magnetos . . . . .	11-19
Inspection . . . . .	11-7		Description . . . . .	11-19
Build-up . . . . .	11-9		Removal and Installation . . . . .	11-19
Installation . . . . .	11-9		Internal Timing . . . . .	11-19
Flexible Fluid Hoses . . . . .	11-9		Replacement Interval . . . . .	11-19
Leak Test . . . . .	11-9		Magneto-to-Engine Timing . . . . .	11-19
Replacement . . . . .	11-10		Maintenance . . . . .	11-20
Static Run-up Procedures . . . . .	11-10		Magneto Check . . . . .	11-21
Engine Baffles . . . . .	11-10		Spark Plugs . . . . .	11-21
Description . . . . .	11-10		Engine Controls . . . . .	11-21
Cleaning and Inspection . . . . .	11-10		Description . . . . .	11-21
Removal and Installation . . . . .	11-10		Rigging . . . . .	11-21
Repair . . . . .	11-11		Throttle Control . . . . .	11-21
Engine Mount . . . . .	11-11		Mixture Control . . . . .	11-21
Description . . . . .	11-11		Carburetor Heat Control . . . . .	11-22
Removal and Installation . . . . .	11-11		Starting System . . . . .	11-22
Repair . . . . .	11-11		Description . . . . .	11-22
Engine Shock-Mount Pads . . . . .	11-11		Trouble Shooting . . . . .	11-23
Engine Oil System . . . . .	11-11		Primary Maintenance . . . . .	11-23
Description . . . . .	11-11		Starter Motor . . . . .	11-24
Trouble Shooting . . . . .	11-12		Removal and Installation . . . . .	11-24
Full-Flow Oil Filter . . . . .	11-14		Exhaust System . . . . .	11-24
Description . . . . .	11-14		Description . . . . .	11-24
Removal and Installation . . . . .	11-14		Removal and Installation . . . . .	11-24
Filter Adapter . . . . .	11-15		Inspection . . . . .	11-24
Removal . . . . .	11-15		Extreme Weather Maintenance . . . . .	11-24
Disassembly, Inspection and			Cold Weather . . . . .	11-24
Reassembly . . . . .	11-16		Hot Weather . . . . .	11-26
Installation . . . . .	11-16		Dusty Conditions . . . . .	11-26
Oil Cooler . . . . .	11-16		Seacoast and Humid Areas . . . . .	11-26
Description . . . . .	11-16		Ground Service Receptacle . . . . .	11-26
Engine Fuel System . . . . .	11-16		Hand Cranking . . . . .	11-27

11-1. ENGINE COWLING.

11-2. DESCRIPTION. The engine cowling is comprised of an upper and lower cowling segment. Instead of attaching directly to the fuselage, the cowling attaches to shock-mounts, which in turn, are fastened to the fuselage. A door in the top cowl provides access to the engine oil dipstick, oil filler neck and strainer drain control. Quick-disconnect fasteners are used at the cowling-to-shock-mounts and at the parting surfaces of the upper and lower cowl attach points. Machine screws secure the cowling segments together at the nose caps.

11-3. REMOVAL AND INSTALLATION.

a. Release the quick-disconnect fasteners attaching

the cowling to the shock-mounts and at the parting surfaces of the upper and lower cowling segments.

b. Remove the machine screws securing the cowling nose caps together.

c. BEGINNING WITH AIRCRAFT SERIAL 17259224 AND F17200755. Disconnect electrical wiring at back of landing light.

d. Reverse the preceding steps for reinstallation. Be sure that the baffle seals are turned in the correct direction to confine and direct airflow around the engine. The vertical seals must fold forward and the side seals must fold upwards.

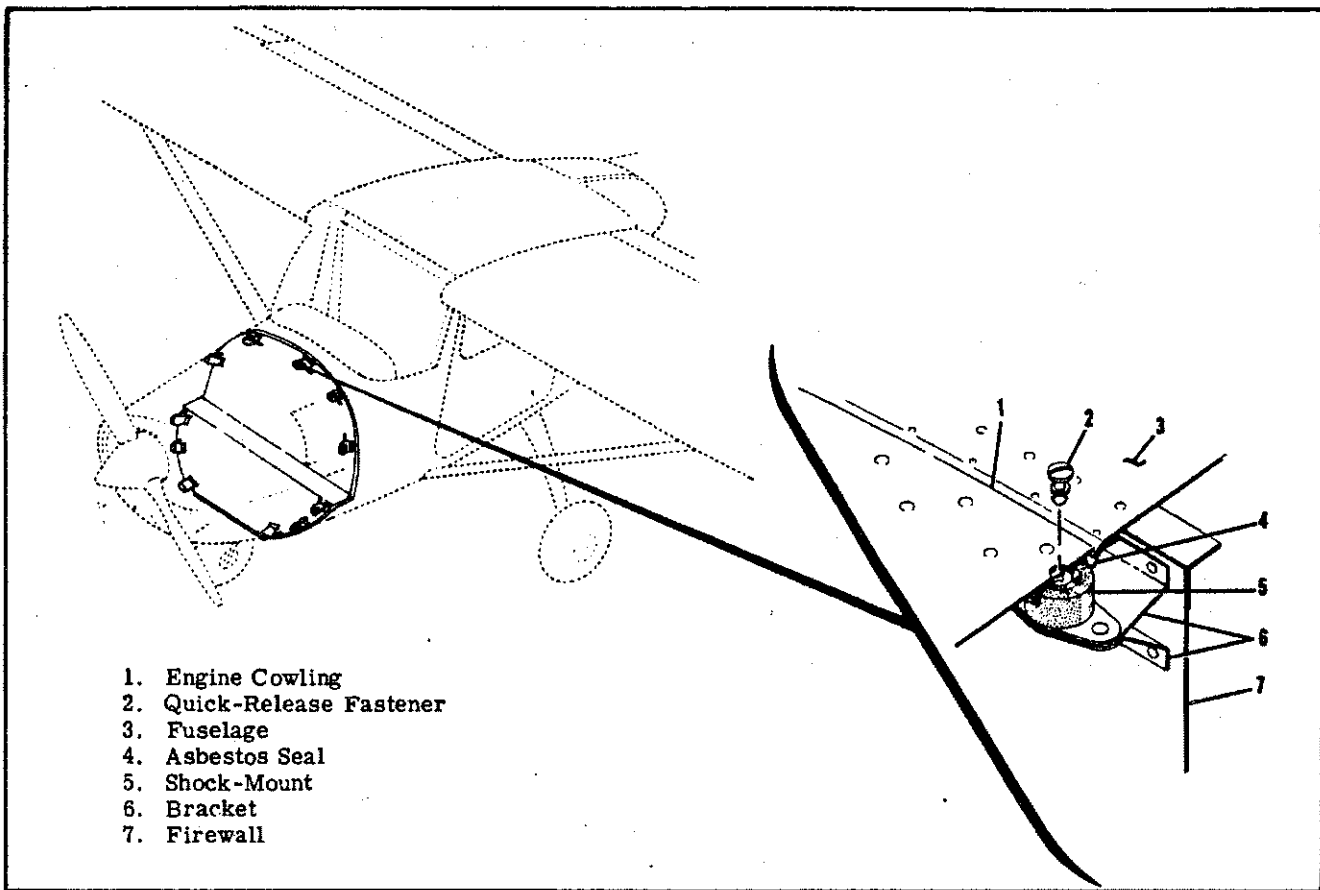

Figure 11-1. Engine Cowling Shock-Mounts

**NOTE**

When new shock-mounts or brackets are being installed, careful measurements should be made to position these parts correctly on the firewall. These service parts are not pre-drilled. Install shock-mounts on brackets so that cowling stud and shock-mount are correctly aligned. Sheet aluminum may be used as shims between bracket halves to provide proper cowling contour.

**11-4. CLEANING AND INSPECTION.** Wipe the inner surfaces of the cowling segments with a clean cloth saturated with cleaning solvent (Stoddard or equivalent). If the inside surface of the cowling is coated heavily with oil or dirt, allow solvent to soak until foreign material can be removed. Wash painted surfaces of the cowling with a solution of mild soap and water and rinse thoroughly. After washing, a coat of wax may be applied to the painted surfaces to prolong paint life. After cleaning, inspect cowling for dents, cracks, loose rivets and spot welds. Repair all defects to prevent spread of damage.

**11-5. REPAIR.** If cowling skins are extensively damaged, new complete sections of the cowling should be installed. Standard insert-type patches may be used for repair if repair parts are formed

to fit contour of cowling. Small cracks may be stop-drilled and small dents straightened if they are reinforced on the inner surface with a doubler of the same material as the cowling skin. Damaged reinforcement angles should be replaced with new parts. Due to their small size, new reinforcement angles are easier to install than to repair the damaged part.

**11-6. ENGINE.**

**11-7. DESCRIPTION.** An air cooled, wet-sump, four-cylinder, horizontally-opposed, direct-drive, carbureted "Blue Streak" (Lycoming) O-320-E series engine is used to power ALL 172 series aircraft. The O-320-E series engine is also used to power the F172 series aircraft beginning with the 1972 model year. The cylinders, numbered from front to rear, are staggered to permit a separate throw on the crankshaft for each connecting rod. The right front cylinder is number 1 and cylinders on the right side are identified by odd numbers 1 and 3. The left front cylinder is number 2 and the cylinders on the left side are identified as numbers 2 and 4. Refer to paragraph 11-8 for engine data. For repair and overhaul of the engine, accessories and propeller, refer to the appropriate publications issued by their manufacturer's. These publications are available from the Cessna Service Parts Center.

11-8. ENGINE DATA.

MODEL (Lycoming)	O-320-E2D
BHP at RPM	150 BHP at 2700 RPM
Number of Cylinders	4-Horizontally Opposed
Displacement	319.8 Cubic Inches
Bore	5.125 Inches
Stroke	3.875 Inches
Compression Ratio	7.0:1
Magnetos	Slick No. 4051 (Left) No. 4050 (Right)
Right Magneto	Fires 25° BTC 1-3 Lower and 2-4 Upper
Left Magneto	Fires 25° BTC 1-3 Upper and 2-4 Lower
Firing Order	1-3-2-4
Spark Plugs	18MM (Refer to Current Lycoming Active Factory Approved Spark Plug Chart)
Torque Value	390±30 Lb-In.
Carburetor (Marvel-Schebler)	MA-4SPA
Oil Sump Capacity	8 U.S. Quarts
With Filter Element Change	9 U.S. Quarts
Tachometer	Mechanical
Approximate Dry Weight	269 Pounds (Weight is Approximate and Will
With Standard Accessories	Vary with Optional Equipment Installed)
Oil Pressure	
Minimum Idling	25 PSI
Normal	60 to 85 PSI
Maximum (Cold Oil Starting)	100 PSI
Oil Temperature	
Normal Operation	Within Green Arc
Maximum Permissible	Red Line (245°F)
Cylinder Head Temperature	500°F Maximum

11-9. TROUBLE SHOOTING.

TROUBLE	PROBABLE CAUSE	REMEDY
ENGINE WILL NOT START.	Improper use of starting procedure.	Review starting procedure.
	Fuel tanks empty.	Visually inspect tanks. Fill with proper grade and quantity of gasoline.
	Mixture control in the IDLE CUT-OFF position.	Move control to the full RICH position.
	Fuel selector valve in OFF position.	Place selector valve in the ON position to a tank known to contain gasoline.
	Defective carburetor.	If engine will start when primed but stops when priming is discontinued, with mixture control in full RICH position, the carburetor is defective. Repair or replace carburetor.
	Carburetor screen or fuel strainer plugged.	Remove carburetor and clean thoroughly. Refer to paragraph 11-44.
	Vaporized fuel. (Most likely to occur in hot weather with a hot engine.)	Refer to paragraph 11-79.
	Engine flooded.	Refer to paragraph 11-79.
	Water in fuel system.	Open fuel strainer drain and check for water. If water is present, drain fuel tank sumps, lines, strainer and carburetor.
	Defective magneto switch or grounded magneto leads.	Check continuity. Repair or replace switch or leads.
Spark plugs fouled.	Remove, clean and regap plugs. Test harness cables to persistently fouled plugs. Replace if defective.	
ENGINE STARTS BUT DIES, OR WILL NOT IDLE.	Idle stop screw or idle mixture incorrectly adjusted.	Refer to paragraph 11-45.
	Carburetor idling jet plugged.	Clean carburetor and fuel strainer. Refer to paragraph 11-44.
	Spark plugs fouled or improperly gapped.	Remove, clean and regap plugs. Replace if defective.
	Water in fuel system.	Open fuel strainer drain and check for water. If water is present, drain fuel tank sumps, lines, strainer and carburetor.
	Defective ignition system.	Refer to paragraph 11-58.



11-9. TROUBLE SHOOTING (Cont).

TROUBLE	PROBABLE CAUSE	REMEDY
ENGINE STARTS BUT DIES, OR WILL NOT IDLE. (Cont.)	Vaporized fuel. (Most likely to occur in hot weather with a hot engine.)	Refer to paragraph 11-79.
	Induction air leaks.	Check visually. Correct the cause of leaks.
	Manual primer leaking.	Disconnect primer outlet line. If fuel leaks through primer, repair or replace primer.
	Leaking float valve or float level set too high.	Perform an idle mixture check. Attempt to remove any rich indication with the idle mixture adjustment. If the rich indication cannot be removed, the float valve is leaking or the float level is set too high. Replace defective parts, reset float level.
	Defective carburetor.	If engine will start when primed but stops when priming is discontinued, with mixture control in full RICH position, the carburetor is defective. Repair or replace carburetor.
	Defective engine.	Check compression. Listen for unusual engine noises. Engine repair is required.
ENGINE RUNS ROUGHLY OR WILL NOT ACCELERATE PROPERLY.	Restriction in aircraft fuel system.	Refer to Section 12.
	Worn or improperly rigged throttle or mixture control.	Check visually. Replace worn Linkage. Rig properly.
	Spark plugs fouled or improperly gapped.	Remove, clean and regap plugs. Replace if defective.
	Defective ignition system.	Refer to paragraph 11-58.
	Defective or badly adjusted accelerating pump in carburetor.	Check setting of accelerating pump linkage and adjust as necessary.
	Float level set too low.	Check and reset float level.
	Defective carburetor.	If engine will start when primed but stops when priming is discontinued, with mixture control in full RICH position, the carburetor is defective. Repair or replace carburetor.
	Defective engine.	Check compression. Listen for unusual engine noises. Engine repair is required.

11-9. TROUBLE SHOOTING (Cont).

TROUBLE	PROBABLE CAUSE	REMEDY
ENGINE RUNS ROUGHLY OR WILL NOT ACCELERATE PROPERLY. (Cont.)	Restricted carburetor air filter.	Check visually. Clean in accordance with Section 2.
	Cracked engine mount.	Inspect and repair or replace mount as required.
	Defective mounting bushings.	Inspect and install new bushings as required.
POOR IDLE CUT-OFF.	Worn or improperly rigged mixture control.	Check that idle cut-off stop on carburetor is contacted. Replace worn linkage. Rig properly.
	Manual primer leaking.	Disconnect primer outlet line. If fuel leaks through primer, it is defective. Repair or replace primer.
	Defective carburetor.	Repair or replace carburetor.
	Fuel contamination.	Check all screens in fuel system. Drain all fuel and flush out system. Clean all screens, lines, strainer and carburetor.

11-10. REMOVAL. If an engine is to be placed in storage or returned to the manufacturer for overhaul, proper preparatory steps should be taken for corrosion prevention prior to beginning the removal procedure. Refer to Section 2 for storage preparation. The following engine removal procedure is based upon the engine being removed from the aircraft with the engine mount attached to the firewall.

**NOTE**

Tag each item when disconnected to aid in identifying wires, hoses, lines and control linkages when engine is reinstalled. Likewise, shop notes made during removal will often clarify reinstallation. Protect openings, exposed as a result of removing or disconnecting units, against entry of foreign material by installing covers or sealing with tape.

- a. Place all cabin switches in the OFF position.
- b. Place fuel selector valve in the OFF position.
- c. Remove engine cowling in accordance with paragraph 11-3.
- d. Disconnect battery cables and insulate terminals as a safety precaution.
- e. Drain fuel strainer and lines with strainer drain control.

**NOTE**

During the following procedures, remove any clamps or lacings which secure controls, wires, hoses or lines to the engine, engine mount or attached brackets, so they will not interfere with engine removal. Some of the items listed can be disconnected at more than one place. It may be desirable to disconnect some of these items at other than the places indicated. The reason for engine removal should be the governing factor in deciding at which point to disconnect them. Omit any of the items which are not present on a particular engine installation.

- f. Drain the engine oil sump and oil cooler.
- g. Disconnect magneto primary lead wires at magnetos.

**WARNING**

The magnetos are in a SWITCH ON condition when the switch wires are disconnected. Ground the magneto points or remove the high tension wires from the magnetos or spark plugs to prevent accidental firing.

- h. Remove the spinner and propeller in accordance with Section 13.

i. Disconnect throttle and mixture controls at carburetor. Remove clamps attaching controls to engine and pull controls aft clear of engine. Use care to avoid bending controls too sharply. Note EXACT position, size and number of attaching washers and spacers for reference on reinstallation.

j. Loosen clamps and remove flexible duct from engine baffle and oil cooler.

k. Loosen clamps and remove flexible duct from muffler shroud and heater valve.

l. Disconnect carburetor heat control at airbox and remove clamp attaching control to bracket. Pull control aft to clear engine.

m. Disconnect wires and cables as follows:

1. Disconnect tachometer drive shaft at adapter.

### CAUTION

When disconnecting starter cable do not permit starter terminal bolt to rotate. Rotation of the bolt could break the conductor between bolt and field coils causing the starter to be inoperative.

2. Disconnect starter electrical cable at starter.
  3. Disconnect cylinder head temperature wire at probe.
  4. Disconnect electrical wires and wire shielding ground at alternator.
  5. Remove all clamps and lacings attaching wires or cables to engine and pull wires and cables aft to clear engine.
- n. Disconnect lines and hoses as follows:
1. Disconnect vacuum hose at firewall fitting.
  2. Disconnect engine breather hose at top of accessory case.

### WARNING

Residual fuel and oil draining from disconnected lines and hoses constitutes a fire hazard. Use caution to prevent accumulation of such fuel and oil when lines or hoses are disconnected.

3. Disconnect oil temperature bulb at adapter.
  4. Disconnect primer line at firewall fitting.
  5. Disconnect fuel supply hose at carburetor.
  6. Disconnect oil pressure line at firewall fitting.
  7. Disconnect oil cooler hoses at cooler.
- o. Carefully check the engine again to ensure ALL hoses, lines, wires, cables, clamps and lacings are disconnected or removed which would interfere with the engine removal. Ensure all wires, cables and engine controls have been pulled aft to clear the engine.
- p. Attach a hoist to the lifting eye at the top center of the engine crankcase. Life engine just enough to relieve the weight from the engine mounts.

### CAUTION

Place a suitable stand under the tail tie-down ring before removing engine. The loss of engine weight will cause the aircraft to be tail heavy.

q. Remove bolts attaching engine to engine mount and slowly hoist engine and pull it forward. Checking for any items which would interfere with the engine removal. Balance the engine by hand and carefully guide the disconnected parts out as the engine is removed.

11-11. CLEANING. The engine may be cleaned with Stoddard solvent or equivalent, then dried thoroughly.

### CAUTION

Particular care should be given to electrical equipment before cleaning. Cleaning fluids should not be allowed to enter magnetos, starter, alternator, etc. Protect these components before saturating the engine with solvent. All other openings should also be covered before cleaning the engine assembly. Caustic cleaning solutions should be used cautiously and should always be properly neutralized after their use.

11-12. ACCESSORIES REMOVAL. Removal of engine accessories for overhaul or for engine replacement involves stripping the engine of parts, accessories and components to reduce it to the bare engine. During the removal process, removed items should be examined carefully and defective parts should be tagged for repair or replacement with new components.

### NOTE

Items easily confused with similar items should be tagged to provide a means of identification when being installed on a new engine. All openings exposed by the removal of an item should be closed by installing a suitable cover or cap over the opening. This will prevent entry of foreign material. If suitable covers are not available, tape may be used to cover the openings.

11-13. INSPECTION. For specific items to be inspected, refer to the engine manufacturer's manual.

- a. Visually inspect the engine for loose nuts, bolts, cracks and fin damage.
- b. Inspect baffles, baffle seals and brackets for cracks, deterioration and breakage.
- c. Inspect all hoses for internal swelling, chafing through protective plys, cuts, breaks, stiffness damaged threads and loose connections. Excessive heat on hoses will cause them to become brittle and easily broken. Hoses and lines are most likely to crack or break near the end fittings and support points.
- d. Inspect for color bleaching of the end fittings or severe discoloration of the hoses.

### NOTE

Avoid excessive flexing and sharp bends when examining hoses for stiffness.

e. All flexible fluid carrying hoses in the engine compartment should be replaced at engine overhaul or every five years, whichever occurs first.

**MOUNT-TO-FIREWALL  
(UPPER)**

**TORQUE MOUNT-TO-FIREWALL  
BOLTS TO 160 - 190 LB-IN**

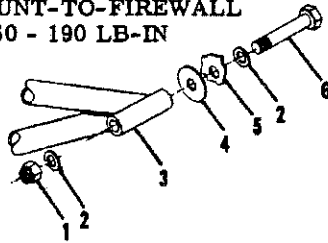

**ENGINE-TO-MOUNT  
(UPPER)**

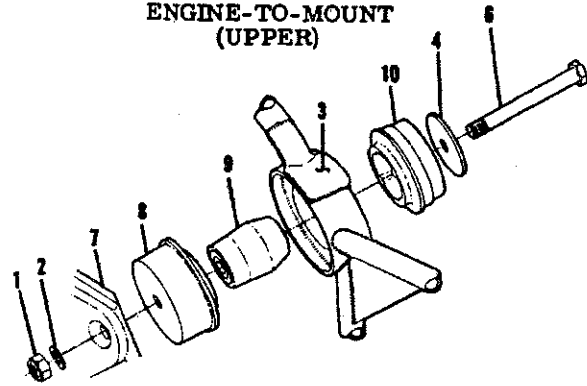

**NOTE**

When installing shock mounts, install shock mount pad (8) as shown for the upper and lower mounts. Also, note on lower mount, washer (4) is installed between engine mount foot and shock mount. This is to prevent starter ring gear from coming in contact with lower cowling.

**MOUNT-TO-FIREWALL  
(LOWER)**

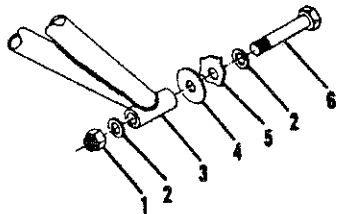

**TORQUE ENGINE-TO-MOUNT  
BOLTS TO 450 - 500 LB-IN**

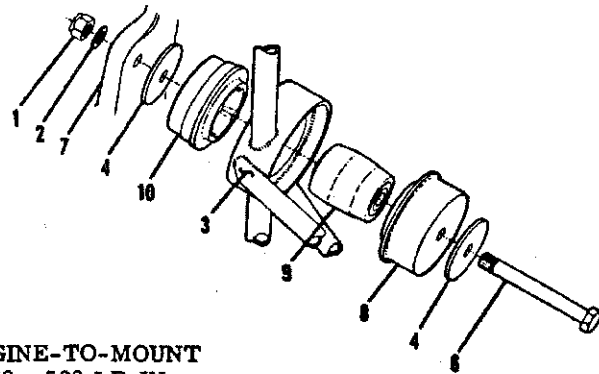

**ENGINE-TO-MOUNT  
(LOWER)**

- 1. Nut
- 2. Washer
- 3. Engine Mount

- 4. Washer
- 5. Firewall
- 6. Bolt
- 7. Engine Mount Foot

- 8. Shock Mount Pad
- 9. Shock Mount Dampener
- 10. Shock Mount Pad

Figure 11-2. Engine Mount Details

f. For major engine repairs, refer to the manufacturer's overhaul and repair manual.

11-14. BUILD-UP. Engine build-up consists of installation of parts, accessories and components to the basic engine to build up an engine unit ready for installation on the aircraft. All safety wire, lock-washers, nuts, gaskets and rubber connections should be new parts.

11-15. INSTALLATION. Before installing the engine on the aircraft, install any items which were removed from the engine or aircraft after the engine was removed.

#### NOTE

Remove all protective covers, plugs, caps and identification tags as each item is connected or installed. Omit any items not present on a particular engine installation.

- a. Hoist the engine to a point near the engine mount.
- b. Install engine shock-mount pads as illustrated in figure 11-2.
- c. Carefully lower engine slowly into place on the engine mount. Route controls, lines, hoses and wires in place as the engine is positioned on the engine mount.

#### NOTE

Be sure engine shock-mount pads, spacers and washers are in place as the engine is lowered into position.

- d. Install engine mount bolts, washers and nuts, then remove the hoist and tail support stand. Torque bolts to 450-500 lb-in.
- e. Route throttle, mixture and carburetor heat controls to the carburetor and airbox and connect. Secure controls in position with clamps.

#### NOTE

Throughout the aircraft fuel system, from the tanks to the carburetor, use NS-40 (RAS-4) (Snap-On-Tools Corp., Kenosha, Wisconsin), MIL-T-5544 (Thread Compound Antiseize, Graphite Petrolatum), USP Petrolatum or engine oil as a thread lubricator or to seal a leaking connection. Apply sparingly to male threads, exercising extreme caution to avoid "stringing" sealer across the end of the fitting. Always ensure that a compound, the residue from a previously used compound, or any other foreign material cannot enter the system.

- f. Connect lines and hoses as follows:
  1. Connect oil cooler hoses at cooler.
  2. Connect oil pressure line at firewall fitting.
  3. Connect fuel supply hose at carburetor.
  4. Connect primer line at firewall fitting.
  5. Connect oil temperature bulb at adapter.
  6. Connect engine breather hose at top of accessory case.

7. Connect vacuum hose at firewall fitting.
8. Install clamps and lacings attaching lines and hoses to engine, engine mount and brackets.
- g. Connect wires and cables as follows:
  1. Connect electrical wires and wire shielding ground at alternator.
  2. Connect cylinder head temperature wire at probe.

#### CAUTION

When connecting starter cable, do not permit starter terminal bolt to rotate. Rotation of the bolt could break the conductor between bolt and field coils causing the starter to be inoperative.

3. Connect starter electrical cable at starter.
4. Connect tachometer drive shaft at adapter. Be sure drive cable engages drive in adapter. Torque housing attach nut to 100 lb-in.
5. Install clamps and lacings securing wires and cables to engine, engine mount and brackets.
- h. Install flexible duct to heater valve and engine baffle and install clamps.
- i. Install flexible duct to engine baffle and oil cooler and install clamps.
- j. Install propeller and spinner in accordance with instructions outlined in Section 13.
- k. Complete a magneto switch ground-out and continuity check, then connect primary lead wires to the magnetos. Remove the temporary ground or connect spark plug leads, whichever procedure was used during removal.

#### WARNING

Be sure magneto switch is in OFF position when connecting switch wires to magnetos.

- l. Clean and install induction air filter.
- m. Service engine with proper grade and quantity of engine oil. Refer to Section 2 if engine is new, newly overhauled or has been in storage.
- n. Check all switches are in the OFF position, and connect battery cables.
- o. Rig engine controls in accordance with paragraphs 11-64, 11-65 and 11-66.
- p. Inspect engine installation for security, correct routing of controls, lines, hoses and electrical wiring, proper safetying and tightness of all components.
- q. Install engine cowling in accordance with paragraph 11-3.
- r. Perform an engine run-up and make final adjustments on the engine controls.

#### 11-16. FLEXIBLE FLUID HOSES.

#### 11-17. LEAK TEST.

- a. After each 50 hours of engine operation, all flexible fluid hoses in the engine compartment should be checked for leaks as follows:
  1. Examine the exterior of hoses for evidence of leakage or wetness.
  2. Hoses found leaking should be replaced.
  3. Refer to paragraph 11-13 for detailed inspection procedures for flexible hoses.

**11-18. REPLACEMENT.**

- a. Hoses should not be twisted on installation. Pressure applied to a twisted hose may cause failure or loosening of the nut.
- b. Provide as large a bend radius as possible.
- c. Hoses should have a minimum of one-half inch clearance from other lines, ducts, hoses or surrounding objects or be butterfly clamped to them.
- d. Rubber hoses will take a permanent set during extended use in service. Straightening a hose with a bend having a permanent set will result in hose cracking. Care should be taken during removal so that hose is not bent excessively, and during reinstallation to assure hose is returned to its original position.
- e. Refer to AC 43.13-1, Chapter 10, for additional installation procedures for flexible fluid hose assemblies.

**11-18A. STATIC RUN-UP PROCEDURES.** In a case of suspected low engine power, a static RPM run-up should be conducted as follows:

- a. Run-up engine, using take-off power and mixture settings, with the aircraft facing 90° right and then

left to the wind direction.

- b. Record the RPM obtained in each run-up position.

**NOTE**

Daily changes in atmospheric pressure, temperature and humidity will have a slight effect on static run-up.

- c. Average the results of the RPM obtained. Refer to following chart for applicable RPM.

d. If the average results of the RPM obtained does not meet the limits specified in the chart, the following recommended checks may be performed to determine a possible deficiency.

1. Check carburetor heat control for proper rigging. If partially open it would cause a slight power loss.
2. Check magneto timing, spark plugs and ignition harness for settings and conditions.
3. Check condition of induction air filter. Clean if necessary.
4. Perform an engine compression check. (Refer to engine Manufacturer's Manual).

MODEL	YEAR	ENGINE	RPM
172	1969 THRU 1971	O-320-E2D	* 2260-2360
172 & F172	1972 AND ON	O-320-E2D	* 2260-2360
172 & F172	17263470, 17263492 THRU 17263494, 17263497, 17263541 THRU 17263558, 17263560 AND ON & F17201255 AND ON	O-320-E2D	2300-2420
* 172 & F172	1969 MODEL 172 AND ON & 1972 MODEL F172 AND ON WHEN CESSNA SINGLE-ENGINE SERVICE LETTER SE74-16 HAS BEEN INCORPORATED	O-320-E2D	2300-2420

**11-19. ENGINE BAFFLES.**

**11-20. DESCRIPTION.** The sheet metal baffles installed on the engine directs the flow of air around the cylinders and other engine components to provide optimum cooling. These baffles incorporate rubber-asbestos composition seals at points of contact with the engine cowling and other engine components to help confine and direct the airflow to the desired area. It is very important to engine cooling that the baffles and seals are in good condition and installed correctly. The vertical seals must fold forward and the side seals must fold upwards. Removal and installation of the various baffle segments is possible with the cowling removed. Be sure that any new baffle seals properly.

**11-21. CLEANING AND INSPECTION.** The engine baffles should be cleaned with a suitable solvent to remove oil and dirt.

**NOTE**

The rubber-asbestos seals are oil and grease resistant but should not be soaked in solvent for long periods.

Inspect baffles for cracks in the metal and for loose and/or torn seals. Repair or replace any defective parts.

**11-22. REMOVAL AND INSTALLATION.** Removal and installation of the various baffle segments is pos-

sible with the cowling removed. Be sure that any replaced baffles and seals are installed correctly and that they seal to direct the airflow in the correct direction. Various lines, hoses, wires and controls are routed through some baffles. Make sure that these parts are reinstalled correctly after installation of baffles.

11-23. **REPAIR.** Repair of an individual segment of engine baffle is generally impractical, since, due to the small size and formed shape of the part, replacement is usually more economical. However, small cracks may be stop-drilled and a reinforcing doubler installed. Other repairs may be made as long as strength and cooling requirements are met. Replace sealing strips if they do not seal properly.

11-24. **ENGINE MOUNT.** (Refer to figure 11-2.)

11-25. **DESCRIPTION.** The engine mount is composed of sections of steel tubing welded together and reinforced with gussets. The mount is fastened to the fuselage at four points. The engine is attached to the engine mount with shock-mount assemblies which absorb engine vibrations.

11-26. **REMOVAL AND INSTALLATION.** Removal of the engine mount is accomplished by removing the engine as outlined in paragraph 11-10, then removing the engine mount from the firewall. On reinstallation torque the mount-to-fuselage bolts to 160-190 lb-in. Torque the engine-to-mount bolts to 450-500 lb-in.

11-27. **REPAIR.** Repair of the engine mount shall be performed carefully as outlined in Section 18. The mount shall be painted with heat-resistant black enamel after welding or whenever the original finish has been removed. This will prevent corrosion.

11-28. **ENGINE SHOCK-MOUNT PADS.** (Refer to figure 11-2.) The bonded rubber and metal shock-mounts are designed to reduce transmission of engine vibrations to the airframe. The rubber pads should be wiped clean with a clean dry cloth.

#### NOTE

Do not clean the rubber pads and dampener assembly with any type of cleaning solvent.

Inspect the metal parts for cracks and excessive wear due to aging and deterioration. Inspect the rubber pads for separation between the pad and metal backing, swelling, cracking or a pronounced set of the pad. Install new parts for all parts that show evidence of wear or damage.

11-29. **ENGINE OIL SYSTEM.**

11-30. **DESCRIPTION.** The lubricating system is of the full pressure, wet sump type. The main bearings, connecting rod bearing, camshaft bearings, valve tappets and push rods, are lubricated by positive pressure. The pistons, piston pins, cams, cylinder walls, valve rockers, valve stems and other internal moving parts are lubricated by oil collectors and oil spray. The pump, which is located in the accessory housing, draws oil through a drilled passage leading from the suction screen located in the sump, a manner as to form an inertia type filter, thus ensuring that only the cleanest oil will reach the bearings. Drilled passages from the rear main bearing supply pressure oil to the crankshaft idler gears. Angular holes are drilled through the main bearings to the rod journals where sludge removal tubes are located. Oil from the main gallery also flows to the cam and valve gear passages and then is conducted through branch passages to the hydraulic tappets and cam shaft bearings. Oil travels out through the hollow push rods to the valve rocker bearings and valve stems. Residual oil from the bearings, accessory drives and rocker boxes flows by gravity to the sump where it passes through the suction screen and is recirculated through the engine. The oil cooler may be controlled by a thermostatically controlled valve or a pressure-operated bypass valve (refer to figure 11-3 for applicable aircraft and engine serial numbers). An external, replaceable element full-flow oil filter is available as optional equipment. This external filter replaces the pressure oil screen when installed.

From the pump, the oil enters a drilled passage to a threaded connection and through a flexible hose to the cooler. Pressure oil from the cooler returns through a flexible hose to a threaded connection on the accessory housing. From there the oil flows through a drilled passage to the pressure screen which is contained in a cast chamber mounted on the accessory housing. If cold oil or obstruction should restrict the flow through the cooler, a cooler bypass valve is provided to pass the pressure oil directly from the pump to the pressure screen. The oil is then filtered through the pressure screen chamber and fed through a drilled passage to the pressure relief valve which is located in the upper right side of the crankcase forward of the accessory housing. This relief valve regulates the engine oil pressure by allowing excessive oil to return to the sump, while the balance of the pressure oil is fed to the main oil gallery in the right half of the crankcase. The oil is distributed from the main gallery by means of a separate drilled passage to each main bearing of the crankshaft. The drilled passages to the bearings are located in such

11-31. TROUBLE SHOOTING.

TROUBLE	PROBABLE CAUSE	REMEDY
NO OIL PRESSURE.	No oil in sump.	Check with dipstick. Fill sump with proper grade and quantity of oil. Refer to Section 2.
	Oil pressure line broken, disconnected or pinched.	Inspect pressure lines. Replace or connect lines as required.
	Oil pump defective.	Remove and inspect. Examine engine. Metal particles from damaged pump may have entered engine oil passages.
	Defective oil pressure gage.	Check with a known good gage. If second reading is normal, replace gage.
	Oil congealed in gage line.	Disconnect line at engine and gage; flush with kerosene. Pre-fill with kerosene and install.
	Relief valve defective.	Remove and check for dirty or defective parts. Clean and install; replace valve if defective.
LOW OIL PRESSURE.	Low oil supply.	Check with dipstick. Fill sump with proper grade and quantity of oil. Refer to Section 2.
	Low viscosity oil.	Drain sump and refill with proper grade and quantity of oil.
	Oil pressure relief valve spring weak or broken.	Remove and inspect spring. Replace weak or broken spring.
	Defective oil pump.	Check oil temperature and oil level. If temperature is higher than normal and oil level is correct, internal failure is evident. Remove and inspect. Examine engine. Metal particles from damaged pump may have entered oil passages.
	Secondary result of high oil temperature.	Observe oil temperature gage for high indication. Determine and correct reason for high oil temperature.
	Leak in pressure or suction line.	Inspect gasket between accessory housing and crankcase. Repair engine as required.
	Dirty oil screens.	Remove and clean oil screens.



11-31. TROUBLE SHOOTING (Cont).

TROUBLE	PROBABLE CAUSE	REMEDY
HIGH OIL PRESSURE.	High viscosity oil.	Drain sump and refill with proper grade and quantity of oil.
	Relief valve defective.	Remove and check for dirty or defective parts. Clean and install; replace valve if defective.
	Defective oil pressure gage.	Check with a known good gage. If second reading is normal, replace gage.
LOW OIL TEMPERATURE.	Defective oil temperature gage or temperature bulb.	Check with a known good gage. If second reading is normal, replace gage. If reading is similar, the temperature bulb is defective. Replace bulb.
	Oil cooler thermostatic valve/bypass valve defective or stuck.	Remove valve and check for proper operation. Replace valve if defective.
HIGH OIL TEMPERATURE.	Oil cooler air passages clogged.	Inspect cooler core. Clean air passages.
	Oil cooler oil passages clogged.	Attempt to drain cooler. Inspect for sediment. Remove cooler and flush thoroughly.
	Thermostatic valve or bypass valve damaged or held open by solid matter.	Feel front of cooler core with hand. If core is cold, oil is bypassing cooler. Remove and clean valve and seat. If still inoperative, replace.
	Low oil supply.	Check with dipstick. Fill sump with proper grade and quantity of oil. Refer to Section 2.
	Oil viscosity too high.	Drain sump and refill with proper grade and quantity of oil.
	Prolonged high speed operation on the ground.	Hold ground running above 1500 rpm to a minimum.
	Defective oil temperature gage.	Check with a known good gage. If second reading is normal. Replace gage.
	Defective oil temperature bulb.	Check for correct oil pressure, oil level and cylinder head temperature. If they are correct, check oil temperature gage for being defective; if similar reading is observed, bulb is defective. Replace bulb.

11-31. TROUBLE SHOOTING (Cont).

TROUBLE	PROBABLE CAUSE	REMEDY
HIGH OIL TEMPERATURE (CONT).	Oil congealed in cooler.	This condition can occur only in extremely cold temperatures. If congealing is suspected, use an external heater or a heated hangar to warm the congealed oil.
OIL LEAK AT FRONT OF ENGINE.	Damaged crankshaft seal.	Replace.
OIL LEAK AT PUSH ROD HOUSING.	Damaged push rod housing oil seal.	Replace.

11-32. FULL-FLOW OIL FILTER. (Refer to figure 11-3.)

11-33. DESCRIPTION. An external oil filter may be installed on the engine. The filter and filter adapter replace the regular engine oil pressure screen and cast chamber on the accessory housing. The filter adapter incorporates mounting provisions for the oil cooler bypass valve and the oil temperature sensing bulb. If the filter element should become clogged, the bypass valve allows engine oil to flow to the engine oil passages.

11-34. REMOVAL AND INSTALLATION. (Refer to figure 11-3.)

NOTE

Filter element replacement kits are available from the Cessna Service Parts Center.

- a. Remove engine cowling in accordance with paragraph 11-3.
- b. Remove both safety wires from filter can and unscrew hollow stud (12) to detach filter assembly from adapter (2) as a unit. Remove assembly from aircraft and discard gasket (5).
- c. Press downward on hollow stud (12) to remove from filter element (9) and can (10). Discard metal gasket (11) on stud (12).
- d. Lift lid (7) off filter can (10) and discard gasket (8).
- e. Pull filter element (9) out of filter can (10).

NOTE

Before discarding removed filter element (9), remove the outer perforated paper cover; using a sharp knife, cut through the folds of the filter element at both ends. Then, carefully unfold the pleated element and examine the material trapped in the element for evidence of internal engine damage, such as

chips or particles from bearings. In new or newly overhauled engines, some small particles or metallic shavings might be found, these are generally of no consequence and should not be confused with particles produced by impacting, abrasion or pressure. Evidence of internal damage found in the oil filter element justifies further examination to determine the cause.

- f. Wash lid (7), hollow stud (12) and filter can (10) in solvent and dry with compressed air.

NOTES

When installing a new filter element (9), it is important that all gaskets are clean, lubricated and positioned properly, and that the correct amount of torque is applied to the hollow stud (12). If the stud is under-torqued, oil leakage will occur. If the stud is over-torqued, the filter can might possibly be deformed, again causing oil leakage.

- Lubricate all rubber grommets in the new filter element, lid gaskets and metal gasket with clean engine oil or general purpose grease before installation. Dry gaskets may cause false torque readings, again resulting in oil leakage.
- Before assembly, place a straightedge across bottom of filter can. Check for distortion or out-of-flat condition greater than 0.010 inch. Install a new filter can if either of these conditions exist.
- After installing a new gasket on lid, turn lid over. If gasket falls, try a different gasket and repeat test. If this gasket falls off, install a new lid.

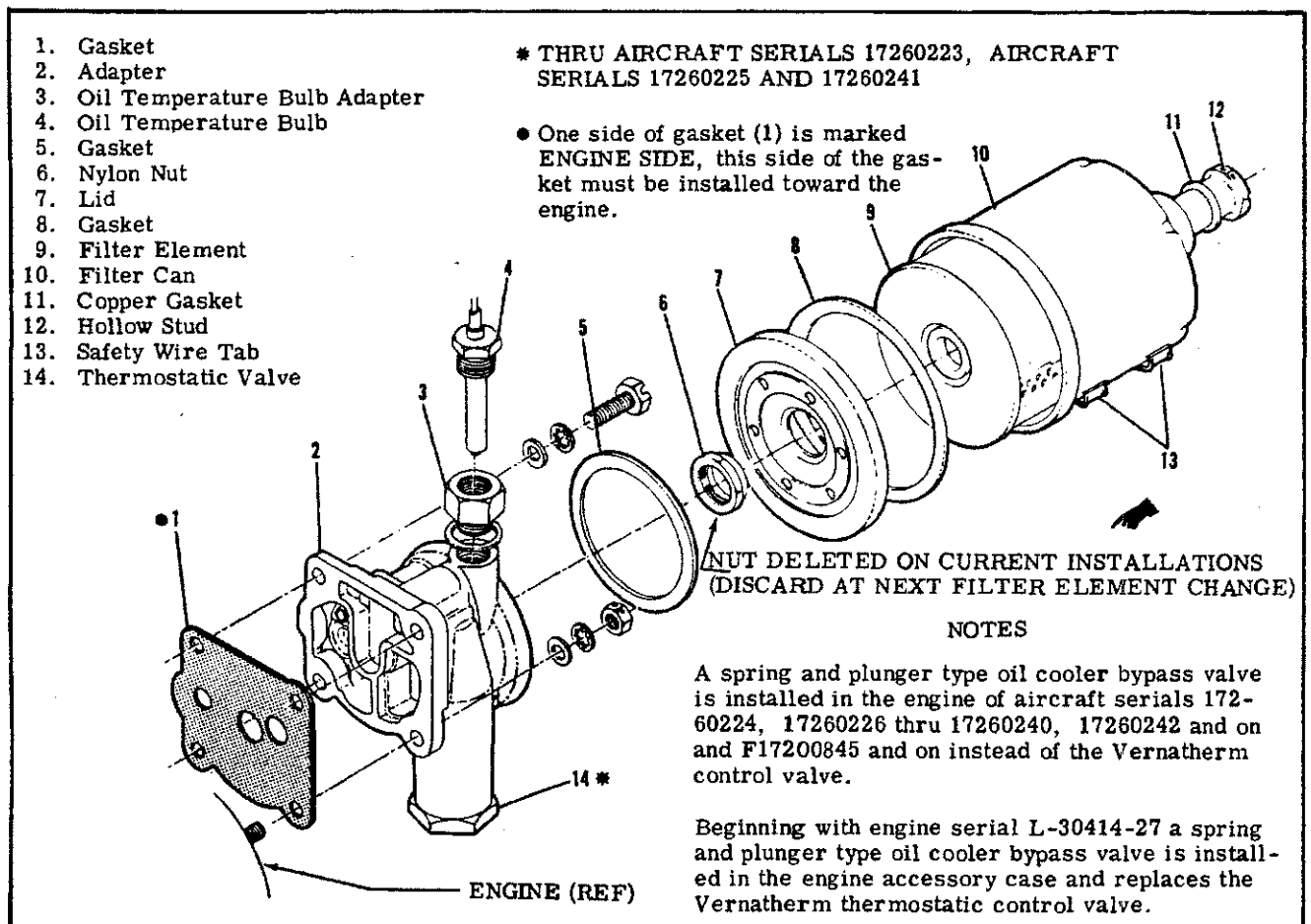

Figure 11-3. Full-Flow Oil Filter

g. Inspect the adapter gasket seat for gouges, deep scratches, wrench marks and mutilation. If any of these conditions are found, install a new adapter.

h. Place a new filter element (9) in can (10) and insert the hollow stud (12) with a new metal gasket (11) in place, through the filter can and element.

i. Position a new gasket (8) inside flange of lid (7). Place lid in position on filter can.

j. With new gasket (5) on face of lid, install filter can assembly on adapter (2) with safety wire tabs (13) on filter can down. While holding filter can to prevent turning, tighten hollow stud (12) and torque to 20-25 lb-ft (240-300 lb-in), using a torque wrench.

k. Install all parts removed for access and service the engine with the proper grade and quantity of engine oil. One additional quart of oil is required each time the filter element is changed.

l. Start engine and check for proper oil pressure. Check for oil leakage after warming up the engine.

m. Again check for oil leakage after engine has been run at high power setting (preferably a flight around the field).

n. Check to make sure filter can has not been making contact with any adjacent parts due to engine torque.

o. While engine is still warm, recheck torque on hollow stud (12) then safety stud to tab (13) on filter can and safety thermostatic valve (14) to tab on filter can.

#### 11-35. FILTER ADAPTER.

#### 11-36. REMOVAL. (Refer to figure 11-3.)

a. Remove filter assembly in accordance with paragraph 11-34.

b. Remove oil temperature bulb (4) from adapter (2).

c. Remove the three bolts and washers attaching adapter to accessory housing.

d. Remove nut and washers attaching the lower left corner of adapter to accessory housing and remove adapter.

e. Remove gasket (1) from adapter mounting pad and discard.

**11-37. DISASSEMBLY, INSPECTION AND RE-ASSEMBLY.** After removal of the adapter (2), remove thermostatic bypass valve (14) for cleaning. Do not disassemble the valve. Clean adapter and thermostatic valve in solvent and dry with compressed air. Ascertain that all passages in adapter are open. Remove any gasket material that may have adhered to the adapter. Inspect adapter for cracks, damaged threads, scratches or gouges to gasket seats. If any of these are found, install a new adapter. Using a new gasket install thermostatic bypass valve in adapter.

**11-38. INSTALLATION.**

- a. Using a good grade of gasket sealant, install a new gasket on accessory housing adapter mount pad. Note that one side of the gasket is marked **ENGINE SIDE**; this side of the gasket must be installed toward the engine.
- b. Install adapter on mounting pad and install bolts, washers and nut. Use lockwashers next to bolt heads and nut.
- c. Tighten bolts and nut to 75 lb-in.
- d. Install oil temperature bulb in adapter.
- e. Install filter assembly in accordance with paragraph 11-34.
- f. Install any components removed for access.

**11-39. OIL COOLER.**

**11-40. DESCRIPTION.** The external oil cooler is mounted on the firewall. Flexible hoses carry the oil to and from the cooler. Cooling air for the cooler is ducted from the upper right engine baffle to the shroud covered oil cooler. Exhaust air from the cooler is discharged into the engine compartment. A thermostatically operated cooler bypass valve may be installed in the oil pressure screen mounting pad or a spring-loaded, pressure-operated bypass valve may be installed in the accessory housing (refer to figure 11-3 for applicable aircraft and engine serial numbers). This valve causes oil to bypass the cooler in the event of congealed oil or an obstruction in the cooler. The bypass valve passes the oil directly to the pressure screen until a predetermined oil temperature or pressure is reached, then oil is routed through the cooler. At each engine oil change, drain the oil cooler.

**11-41. ENGINE FUEL SYSTEM.**

**11-42. DESCRIPTION.** A single barrel, float-type, up-draft carburetor is installed on the engine. The carburetor is equipped with a manual mixture control and an idle cut-off. For repair and overhaul of the carburetor refer to the manufacturer's overhaul and repair manual.

**11-43. CARBURETOR.**

**11-44. REMOVAL AND INSTALLATION.**

- a. Place fuel selector valve in the OFF position.
- b. Remove engine cowling in accordance with paragraph 11-3.

- c. Drain fuel from strainer and lines with strainer drain control.
- d. Disconnect throttle and mixture controls at carburetor. Note the EXACT position, size and number of washers and spacers for reference on reinstallation.
- e. Disconnect and cap or plug fuel line at carburetor.
- f. Remove induction airbox.
- g. Remove nuts and washers attaching carburetor to intake manifold and remove carburetor.
- h. Reverse the preceding steps for reinstallation. Use new gasket between carburetor and intake manifold. Check carburetor throttle arm to idle stop arm attachment for security and proper safetying at each normal engine inspection in accordance with figure 11-5.

**11-45. IDLE SPEED AND MIXTURE ADJUSTMENTS.**

Since idle rpm may be affected by idle mixture adjustment, it may be necessary to readjust idle rpm after setting the idle mixture.

- a. Start and run engine until the oil and cylinder head temperature are in the normal operating range.
- b. Check the magnetos for proper operation in accordance with paragraph 11-59.
- c. Clear the engine by advancing the rpm to approximately 1000, then retard the throttle to the idle position. The engine rpm should stabilize at  $600 \pm 25$ . If not, adjust the idle speed screw IN to increase and OUT to decrease rpm.

**NOTE**

An engine should idle smoothly, without excessive vibrations. The idle speed should be high enough to maintain idling oil pressure and to preclude any possibility of engine stoppage in flight when the throttle is closed.

- d. After the idle speed has stabilized ( $600 \pm 25$  rpm), move the mixture control slowly toward the **IDLE CUT-OFF** position and observe the tachometer for any minute change during this manual leaning procedure.
- e. Quickly return the mixture control to the **FULL RICH** position before the engine stops.
- f. A momentary increase of approximately 25 rpm while slowly manually leaning the mixture is most desirable, an increase of more than 25 rpm indicates a rich idle mixture and an immediate decrease in rpm (if not preceded by a momentary increase) indicates a lean idle mixture.
- g. If the idle mixture is too rich, turn the idle mixture adjustment center screw one or two notches in a clockwise direction as viewed from the aft end of the unit, then repeat steps "d" through "f."

**NOTE**

After each adjustment to the idle mixture, run engine up to approximately 1800 rpm to clear the engine of excess fuel and obtain a correct idle speed.



11-51. TROUBLE SHOOTING.

TROUBLE	PROBABLE CAUSE	REMEDY
ENGINE FAILS TO START.	Defective ignition switch.	Check switch continuity. Replace if defective.
	Spark plugs defective, improperly gapped or fouled by moisture or deposits.	Clean, regap and test plugs. Replace if defective.
	Defective ignition harness.	If no defects are found by a visual inspection, check with a harness tester. Replace defective parts.
	Magneto "P" lead grounded.	Check continuity. "P" lead should not be grounded in the ON position, but should be grounded in OFF position. Repair or replace "P" lead.
	Failure of impulse coupling.	Impulse coupling pawls should engage at cranking speeds. Listen for loud clicks as impulse couplings operate. Remove magnetos and determine cause. Replace defective magneto.
	Defective magneto.	Refer to paragraph 11-58.
	Broken drive gear.	Remove magneto and check magneto and engine gears. Replace defective parts. Make sure no pieces of damaged parts remain in engine or engine disassembly will be required.
ENGINE WILL NOT IDLE OR RUN PROPERLY.	Spark plugs defective, improperly gapped or fouled by moisture or deposits.	Clean, regap and test plugs. Replace if defective.
	Defective ignition harness.	If no defects are found by a visual inspection, check with a harness tester. Replace defective parts.
	Defective magneto.	Refer to paragraph 11-58.
	Impulse coupling pawls remain engaged.	Listen for loud clicks as impulse coupling operates. Remove magneto and determine cause. Replace defective magneto.
	Spark plugs loose.	Check and install properly.

## 11-52. MAGNETOS.

11-53. DESCRIPTION. Sealed, lightweight Slick magnetos are used on the aircraft. Magneto Model No. 4051 incorporating an impulse coupling is used as the left magneto, while magneto Model No. 4050 (direct drive) is used as the right magneto. These magnetos **MUST NOT BE DISASSEMBLED**. Internal timing is fixed and breaker points are not adjustable. Timing marks are provided on the distributor gear and distributor block, visible through the air vent holes, for timing to the engine. A timing hole is provided in the bottom of the magneto adjacent to the magneto flange. A timing pin (or 0.093 inch 6-penny nail) is inserted through this timing hole into the mating hole in the rotor shaft to lock the magneto approximately in the proper firing position.

### **WARNING**

During all magneto maintenance always take proper precautions to make sure the engine cannot fire or start when the propeller is moved.

## 11-54. REMOVAL AND INSTALLATION.

- a. Remove engine cowling in accordance with paragraph 11-3.
- b. Remove high-tension outlet plate and disconnect magneto "P" lead.
- c. Remove nuts and washers securing magneto to the engine. Note the approximate angular position at which the magneto is installed, then remove the magneto.
- d. Reverse the preceding steps for reinstallation and time magneto-to-engine in accordance with paragraph 11-57.

11-55. INTERNAL TIMING. Internal timing is accomplished during manufacture of the magneto. Since these magnetos are **NOT TO BE DISASSEMBLED**, there is no internal timing.

11-56. REPLACEMENT INTERVAL. These magnetos cannot be overhauled in the field. The coil, capacitor and breaker assembly are non-replaceable. As a good maintenance practice and to have the benefit of good ignition at all times, it is recommended that the magnetos be removed at 900 hours of magneto time and new exchange magnetos installed.

11-57. MAGNETO-TO-ENGINE TIMING. The magneto must be installed with its timing marks correctly aligned, with number one cylinder on its compression stroke and with the number one piston at its advanced firing position. Refer to paragraph 11-8 for the advanced firing position of number one piston. To locate the compression stroke of the number one cylinder, remove the lower spark plug from number 2, 3 and 4 cylinders. Remove the upper spark plug from number 1 cylinder and then place the thumb of one hand over the spark plug hole of number one cylinder and rotate crankshaft in the direction of normal rotation until the compression stroke is indicated by positive pressure inside the cylinder lifting the thumb off the spark plug hole. After the compression stroke is attained, locate number one piston at its advanced

firing position. Locating the advanced firing position of number one piston may be obtained by rotating the crankshaft opposite to its normal direction of rotation until it is approximately 30 degrees before top dead center (BTC) on the compression stroke of number one cylinder. Rotate crankshaft in a normal direction to align the timing mark on the front face of the starter ring gear support with the drilled hole in the starter, making sure the final motion of the ring gear is in direction of normal rotation.

### NOTE

The starter ring gear must always be in this position when either magneto is locked in position.

When the cylinder is in the correct firing position, install and time the magneto to the engine in the following manner.

### NOTE

Install the magneto drive coupling retainer and rubber bushings into the magneto drive gear hub slot. Insert the two rubber bushings into the retainer with chamfered edges toward the operator when looking into the magneto mount pad on the engine.

- a. Remove the ventilating plug from the bottom of the magneto. The ventilating plug in the top of the magneto need not be removed.
- b. Rotate magneto shaft until timing marks are visible through the ventilation plug hole.
- c. Establish that the magneto is at the number one firing position. It is possible for the timing mark to be visible while firing position is 180 degrees from number one firing position.

### NOTE

It is necessary to "spark" the magneto to establish the correct firing position. The outlet plate with the spark plug leads must be installed. Hold number one spark plug lead (refer to figure 11-4) close to magneto case, or ground the magneto and hold the number one spark plug lead close to a good ground. Rotate impulse coupling (left magneto) or drive coupling (right magneto) in normal direction of rotation until a spark occurs at this lead. (Impulse coupling pawls must be depressed to turn magneto shaft in normal direction of rotation.) Turn coupling or drive coupling backwards a few degrees, until timing mark is centered in ventilating plug hole and install timing pin (or 0.093 inch 6-penny nail) through hole in bottom of magneto next to flange and into mating hole in the rotor shaft. This locks the magneto approximately in firing position while installing on the engine.

- d. If timing pin is not used, keep timing mark centered in ventilating plug hole during magneto installation.

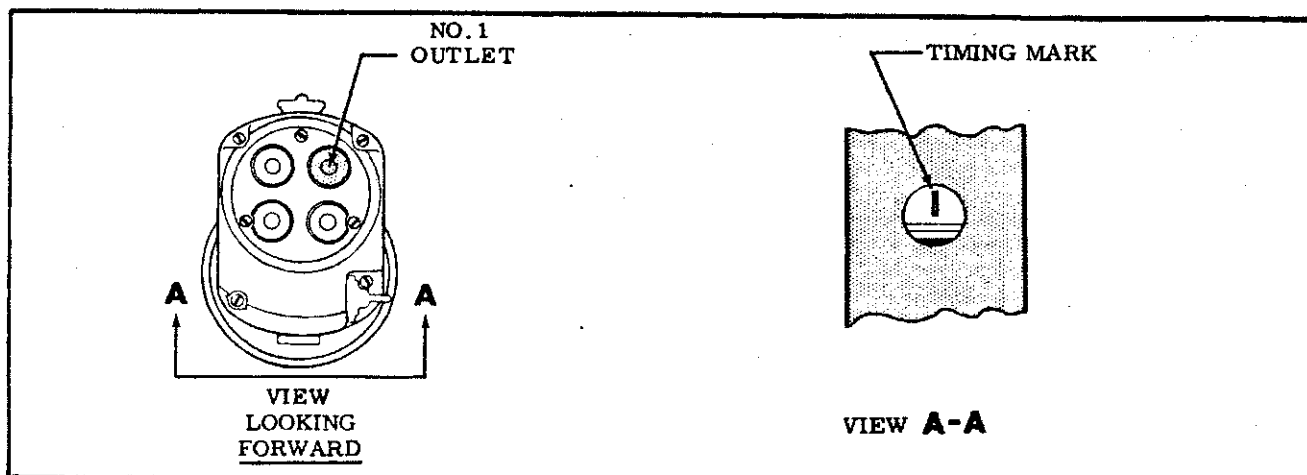

Figure 11-4. No. 1 Magneto Outlet

e. Be sure magneto gasket (right magneto), magneto adapter and gaskets (left magneto) are in place and that the engine is in the correct firing position, then install magneto approximately at the angle noted during removal, tighten mounting nuts finger tight.

**NOTE**

Remove timing pin (or nail) from magneto, if installed. Be sure to remove this pin before rotating propeller.

f. Connect a timing light to the capacitor (primary lead) terminal at the rear of the magneto and to a good ground.

g. Rotate propeller opposite to normal direction of rotation a few degrees (approximately 5 degrees) to close magneto contact points.

**NOTE**

Do not rotate propeller back far enough to engage impulse coupling, or propeller will have to be rotated in normal direction of rotation until impulse coupling releases, then again backed up to a few degrees before the firing position.

h. Slowly advance propeller (tap forward with minute movements as firing position is approached) in normal direction of rotation until timing light indicates position at which contacts break. The contacts should break at the advanced firing position of number one cylinder. Loosen mounting nuts slightly and rotate magneto case to cause the contacts to break at the correct position. Tighten mounting nuts.

i. After tightening magneto mounting nuts, recheck timing. Make sure both magnetos are set to fire at the same time. Remove timing equipment, install

spark plugs and connect spark plug leads and ignition switch leads.

**NOTE**

Beginning with the number one outlet, the magneto fires at each successive outlet in a counter-clockwise direction, looking at the outlets. Connect number one magneto outlet to number one cylinder spark plug lead, number two outlet to the next cylinder to fire, etc. Engine firing order is listed in paragraph 11-8.

11-58. MAINTENANCE. Magneto-to-engine timing should be checked at the first 50 hours, first 100 hours and thereafter at each 200 hours. If timing to the engine is not within plus zero degrees and minus two degrees, the magneto should be retimed to the engine.

**NOTE**

If ignition trouble should develop, spark plugs and ignition wiring should be checked first. If the trouble appears definitely to be associated with a magneto, the following may be used to help disclose the source of trouble.

- a. Remove high-tension outlet plate and check distributor block for moisture.
- b. If any moisture is evident, lightly wipe with a soft, dry, clean, lint-free cloth. Install outlet plate.

**NOTE**

Since these magnetos **MUST NOT BE DISASSEMBLED**, a new magneto should be installed if the moisture check does not remedy the trouble.



#### 11-59. MAGNETO CHECK.

- a. Start and run engine until the oil and cylinder head temperatures are in the normal operating ranges.
- b. Advance engine speed to 1700 rpm.
- c. Turn the ignition switch to the "R" position and note the rpm drop, then return the switch to the "BOTH" position to clear the opposite set of plugs.
- d. Turn the switch to the "L" position and note the rpm drop, then return the switch to the "BOTH" position.
- e. The rpm drop should not exceed 125 rpm on either magneto or show greater than 50 rpm differential between magnetos. A smooth rpm drop-off past normal is usually a sign of a too lean or too rich mixture. A sharp rpm drop-off past normal is usually a sign of a fouled plug, a defective harness lead or a magneto out of time. If there is doubt concerning operation of the ignition system, rpm checks at a leaner mixture setting or at higher engine speeds will usually confirm whether a deficiency exists.

#### NOTE

An absence of rpm drop may be an indication of faulty grounding of one side of the ignition system, a disconnected ground lead at magneto or possibly the magneto timing is set too far in advance.

11-60. SPARK PLUGS. Two 18-mm spark plugs are installed in each cylinder and screw into helicoil type thread inserts. The spark plugs are shielded to prevent spark plug noise in the radios and have an internal resistor to provide longer terminal life. Spark plug life will vary with operating conditions. A spark plug that is kept clean and properly gapped will give better and longer service than one that is allowed to collect lead deposits and is improperly gapped.

#### NOTE

At each 100-hour inspection, remove, clean, inspect and regap all spark plugs. Install lower spark plugs in upper portion of cylinders and install upper spark plugs in lower portion of cylinders. Since deterioration of lower spark plugs is usually more rapid than that of the upper plugs, rotating helps prolong spark plug life.

#### 11-61. ENGINE CONTROLS.

11-62. DESCRIPTION. The throttle, mixture and carburetor heat controls are of the push-pull type. The throttle control is equipped with a friction locking device to prevent vibration-induced "creeping" of the control. The mixture and carburetor heat controls have no locking devices.

11-63. RIGGING. When adjusting any engine control, it is important to check that the control slides smoothly throughout its full range of travel, that it locks securely if equipped with a locking device and the arm or lever it operates moves through its full arc of travel.

#### CAUTION

Whenever engine controls are being disconnected, pay particular attention to the EXACT position, size and number of attaching washers and spacers. Be sure to install attaching parts as noted when connecting controls.

#### 11-64. THROTTLE CONTROL.

#### NOTE

Before rigging throttle control shown in figure 11-5, check that staked connection (4) between rigid conduit (2) and flexible conduit (3) is secure. If any indication of looseness or breakage is apparent, replace the throttle control before continuing with the rigging procedure.

- a. Pull throttle control out (idle position) and remove throttle control knob (1).
- b. Screw jam nut (7) all the way down (clockwise) and install throttle knob. Screw the knob securely against the jam nut. Do not back jam nut out. This will prevent bottoming and possible damage to the staked connection.
- c. Disconnect throttle control at the carburetor throttle arm, push throttle control in until jam nut hits friction lock (6) while the friction lock is loose, then pull control out approximately 1/8 inch for cushion. Note position of large washer at carburetor end of control. Install washer in same position when connecting control to arm.
- d. Tighten friction lock (6), being careful not to change position of the throttle.
- e. Move throttle arm on carburetor to full open, adjust rod end at end of throttle control to fit and connect to arm on carburetor.
- f. Release friction lock and check full travel of arm on carburetor. If further adjustment is required, make all adjustment at the carburetor end of control. DO NOT change jam nut (7) setting.
- g. Tighten rod end locknuts at carburetor end of control. Be sure to maintain sufficient thread engagement between rod end and control.

#### NOTE

Refer to the inspection chart in Section 2 for inspection and/or replacement interval for the throttle control.

#### 11-65. MIXTURE CONTROL.

- a. Push mixture control full in, then pull it out approximately 1/8 inch for cushion.
- b. Loosen clamp securing the control to the engine.
- c. Shift control housing in the clamp so that the mixture arm on the carburetor is in the full open position (RICH). Tighten the clamp in this position.
- d. Unlock and pull mixture control full out. Check that idle mixture arm on carburetor is full closed (IDLE CUT-OFF).
- e. Check that the bolt and nut at the mixture arm on carburetor secures the control wire and that the bolt will swivel in the arm.

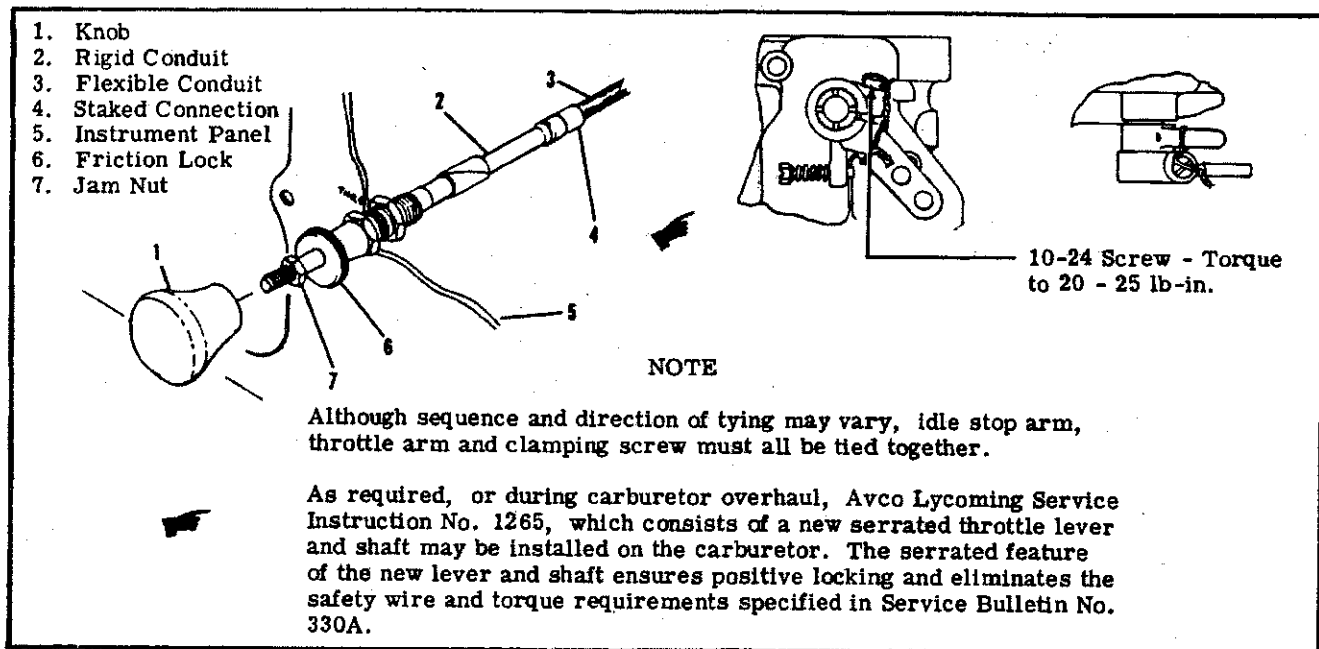

Figure 11-5. Throttle Control

f. Bend the wire tip 90 degrees to prevent it from being withdrawn if the attaching nut should become loose.

g. When installing a new control, it may be necessary to shorten the wire and/or control housing.

h. The mixture arm on the carburetor must contact the stops in each direction, and the control should have approximately 1/8 inch cushion when pushed in.

**NOTE**

Refer to the inspection chart in Section 2 for inspection and/or replacement interval for the mixture control.

**11-66. CARBURETOR HEAT CONTROL.**

a. Loosen clamp securing the control to the bracket on engine.

b. Push control full in, then pull it out approximately 1/8 inch from panel for cushion.

c. Shift control housing in its clamp so that the valve in the airbox is seated in the full open position. Tighten clamp in this position.

d. Pull out on the control and check that the air valve inside the airbox seats in the opposite direction.

e. Check that bolt and nut on the air valve lever secures the control wire and that the bolt will swivel in the lever.

f. Bend the wire tip 90 degrees to prevent it from being withdrawn if the attaching nut should become loose.

**NOTE**

Refer to the inspection chart in Section 2 for inspection and/or replacement interval for the carburetor heat control.

**11-67. STARTING SYSTEM.**

**11-68. DESCRIPTION.** The starting system employs an electrical starter motor mounted at the front (propeller end) lower left side of the engine. A starter solenoid is activated by the ignition key on the instrument panel. When the solenoid is activated, its contacts close and electrical current energizes the starter motor. Initial rotation of the starter armature shaft, engaged with the reduction gear, drives the Bendix shaft and pinion. When the armature turns the reduction gear, the Bendix drive pinion meshes with the crankshaft ring gear assembly by inertia and action of the screw threads within the Bendix sleeve. A detent pin engages in a notch in the screw threads which prevents demeshing if the engine fails to start when the starting circuit is de-energized. When the engine reaches a predetermined speed, centrifugal action forces the detent pin out of the notch in the screw shaft and allows the pinion to demesh from the ring gear.

**CAUTION**

Never operate the starter motor more than 12 seconds at a time. Allow starter motor to cool between cranking periods to avoid overheating. Longer cranking periods without cooling time will shorten the life of the starter motor.

11-69. TROUBLE SHOOTING

TROUBLE	PROBABLE CAUSE	REMEDY
STARTER WILL NOT OPERATE.	Defective master switch or circuit.	Check continuity of master switch and circuit. Install new switch or wires.
	Defective starter switch or switch circuit.	Check continuity of switch and circuit. Install new switch or wires.
	Defective starter motor.	Check voltage to starter. If voltage is present. Remove, repair or install new starter motor.
STARTER MOTOR RUNS, BUT DOES NOT TURN CRANK-SHAFT.	Defective Bendix drive.	Remove starter and inspect Bendix drive. Replace defective parts.
	Damaged starter pinion gear or ring gear.	Inspect starter pinion gear and ring gear. Replace defective parts.
STARTER MOTOR DRAGS.	Low battery.	Check battery. Charge or install new battery.
	Starter switch or relay contacts burned or dirty.	Install serviceable unit.
	Defective starter motor power cable.	Inspect cable. Install new cable.
	Loose or dirty connections.	Inspect connections. Remove, clean and tighten all terminal connections.
	Defective starter motor.	Check starter motor brushes, brush spring tension, thrown solder on brush cover. Repair or install new starter motor.
	Dirty or worn commutator.	Inspect commutator. Clean and turn commutator.
STARTER EXCESSIVELY NOISY.	Worn starter pinion gear or broken teeth on ring gear.	Inspect starter pinion gear and ring gear. Replace defective parts.

11-70. PRIMARY MAINTENANCE. The starting circuit should be inspected at regular intervals, the frequency of which should be determined by the service and conditions under which the equipment is operated.

Inspect the battery and wiring. Check battery for fully charged condition, proper electrolyte level with approved water and terminals for cleanliness. Inspect wiring to be sure that all connections are clean

and tight and that the wiring insulation is sound. Check that the brushes slide freely in their holders and make full contact on the commutator. When brushes are worn to one-half of their original length, install new brushes (compare brushes with new ones). Check the commutator for uneven wear, excessive glazing or evidence of excessive arcing. If the commutator is only slightly dirty, glazed or discolored, it may be cleaned with a strip of No. 00 or No. 000 sandpaper. If the commutator is rough or worn, it should be turned in a lathe and the mica undercut. Inspect the armature shaft for rough bearing surfaces. New brushes should be properly seated when installing by wrapping a strip of No. 00 sandpaper around the commutator (with sanding side out) 1-1/4 to 1-1/2 times maximum. Drop brushes on sandpaper covered commutator and turn armature slowly in the direction of normal rotation. Clean sanding dust from motor after sanding.

#### 11-71. STARTER MOTOR.

#### 11-72. REMOVAL AND INSTALLATION.

a. Remove engine cowling in accordance with paragraph 11-3.

#### **CAUTION**

When disconnecting or connecting the starter cable, do not permit starter terminal bolt to rotate. Rotation of the bolt could break the conductor between terminal and field coils causing the starter to be inoperative.

b. Disconnect electrical cable at starter motor. Insulate the disconnected cable terminal as a safety precaution.

c. Remove three nuts and washers and one bolt securing starter to crankcase. Work starter from engine.

d. To install starter, position starter on mounting pad, aligning dowel pins in starter mounting pad with holes in mounting pad on engine.

e. Secure starter with washer, lockwasher and nut in three places and install bolt and washers.

f. Tighten nuts and bolt evenly to a torque value of 150 lb-in.

g. Connect electrical cable to starter terminal and install engine cowling.

#### 11-73. EXHAUST SYSTEM. (Refer to figure 11-6.)

11-74. DESCRIPTION. The exhaust system consists of an exhaust pipe from each cylinder to the muffler located beneath the engine. The muffler assembly is enclosed in a shroud which captures exhaust heat that is used to heat the aircraft cabin. A shroud on number three exhaust pipe is used to capture carburetor heat for the engine intake system. The tailpipe welded to the muffler routes the exhaust gasses overboard.

#### 11-75. REMOVAL AND INSTALLATION.

a. Remove engine cowling in accordance with paragraph 11-3.

b. Disconnect flexible ducts from shrouds on muffler assembly and exhaust pipe.

c. Remove nuts, bolts, washers and clamps attach-

ing exhaust pipes to muffler assembly.

d. Loosen nuts attaching exhaust pipes to the cylinders and remove muffler assembly.

e. Remove nuts and washers attaching exhaust pipes to the cylinders and remove pipes and gaskets.

f. Reverse the preceding steps for reinstallation. Install a new copper-asbestos gasket between each exhaust pipe and its mounting pad. When installing the attaching nuts, install a plain washer, an internal tooth washer and nut. Make sure all clamps attaching muffler to exhaust pipes are tight and all air ducts are installed.

#### 11-76. DESCRIPTION.

#### **WARNING**

Any time exhaust fumes are detected in the cabin, an immediate inspection must be performed.

The exhaust system must be thoroughly inspected, especially the heat exchange section of the muffler. An inspection of the exhaust system must be performed every 100 hours of operating time. All components that show cracks and general deterioration must be replaced with new parts. Using a flashlight and mirror inspect diffuser tubes through the tailpipe. Replace muffler if defective.

a. Remove engine cowling in accordance with paragraph 11-3.

b. Loosen or remove shrouds so that ALL surfaces of the exhaust system are visible.

c. Check for holes, cracks and burned spots. Especially check the areas adjacent to welds. Look for exhaust gas deposits in surrounding areas which indicate an exhaust leak.

d. Where a surface is not accessible for visual inspection or for a positive test, proceed as follows:

1. Remove exhaust pipes and muffler.

2. Remove shrouds.

3. Seal openings with expansion rubber plugs.

4. Using a manometer or gage, apply approximately 3 ± 1/2 psi (6 inches of mercury) air pressure while the unit is submerged in water. Any leaks will appear as bubbles and can be readily detected.

5. It is recommended that any components found defective be replaced with new parts before the next flight.

6. If no defects are found, remove plugs and dry components with compressed air.

e. Install the exhaust system and engine cowling.

#### 11-77. EXTREME WEATHER MAINTENANCE.

11-78. COLD WEATHER. Cold weather starting is made easier by the installation of the manually-operated engine primer system. Fuel is supplied by a line from the fuel strainer to the plunger type primer. Operating the primer forces fuel to the intake valve port of the cylinder. Primer lines should be replaced when crushed or broken and should be properly clamped to prevent vibration and chafing. With an external power receptacle installed, an external power source may be connected to assist in cold weather or low battery starting. Refer to paragraph 11-82 for use of the external power receptacle.

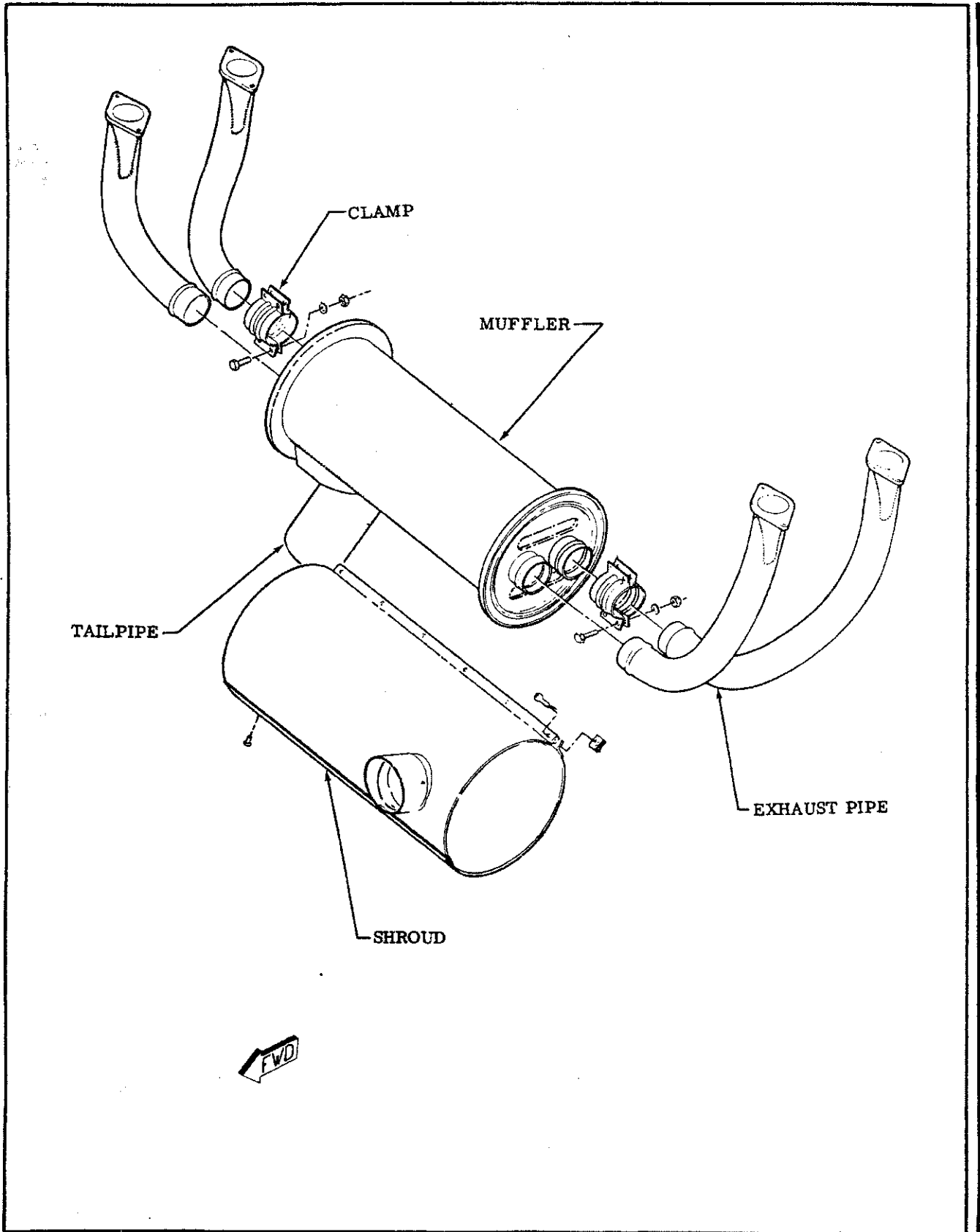

Figure 11-6. Exhaust System

The following may also be used to assist engine starting in extreme cold weather. After the last flight of the day, drain the engine oil into a clean container so the oil can be preheated. Cover the engine to prevent ice or snow from collecting inside the cowling. When preparing the aircraft for flight or engine run-up after these conditions have been followed, preheat the drained oil.

### **WARNING**

Do not heat the oil above 121°C (250°F). A flash fire may result. Before pulling the propeller through, ascertain that the magneto switch is in the OFF position to prevent accidental firing of the engine.

After preheating the oil, fuel may be mixed with the heated oil in a ratio of 1 part fuel to 12 parts oil before pouring into the engine oil sump. If the free air temperature is below -29°C (-20°F), the engine compartment should be preheated by a ground heater. After the engine compartment has been preheated, inspect all engine drain and vent lines for presence of ice. After this procedure has been complied with, pull the propeller through several revolutions by hand before starting engine.

### **CAUTION**

Due to the desludging effect of the diluted oil, engine operation should be observed closely during the initial warm-up of the engine. Engines that have considerable amount of operational hours accumulated since their last dilution period may be seriously affected by the dilution process. This will be caused by the diluted oil dislodging sludge and carbon deposits within the engine. This residue will collect in the oil sump and possibly clog the screened inlet to the oil pump. Small deposits may actually enter the oil pump and be trapped by the main oil filter screen. Partial or complete loss of engine lubrication may result from either condition. If these conditions are anticipated after oil dilution, the engine should be run for several minutes at normal operating temperatures and then stopped and inspected for evidence of sludge and carbon deposits in the oil sump and oil filter screen. Future occurrence of this condition can be prevented by diluting the oil prior to each oil change. This will prevent the accumulation of the sludge and carbon deposits.

11-79. **HOT WEATHER.** Engine starting in hot weather or with a hot engine is sometimes hampered by vapor formation at certain points in the fuel system. To purge the vapor, remove the carburetor vent plug and purge the carburetor and lines by turning the fuel selector valve on. Purge the carburetor in this manner until fuel stands level with the vent plug opening. Replace the carburetor vent plug and operate the engine to make sure that the condition has been corrected.

Engine mis-starts characterized by weak intermittent explosions followed by puffs of black smoke from the exhaust are caused by over-priming or flooding. This situation is more apt to develop in hot weather, or when the engine is hot. If it occurs, repeat the starting procedure with the throttle approximately one-half OPEN and the mixture control in IDLE CUT-OFF. As the engine fires, move mixture control to full RICH and decrease the throttle setting to desired idling speed.

Engine mis-starts characterized by sufficient power to disengage the starter but dying after three to five revolutions are the result of an excessively lean mixture after the start. This can occur in either warm or cold temperatures. Repeat the starting procedure with additional priming.

### **CAUTION**

Never operate the starting motor more than 12 seconds at a time. Allow starter motor to cool between cranking periods to avoid overheating. Longer cranking periods will shorten the life of the starter motor.

11-80. **DUSTY CONDITIONS.** Dust induced into the intake system of the engine is probably the greatest single cause of early engine wear. When operating under high dust conditions, service the induction air filter daily as outlined in Section 2. Also, change engine oil and lubricate the airframe more often than specified.

11-81. **SEACOAST AND HUMID AREAS.** In salt water areas, special care should be taken to keep the engine and accessories clean to prevent oxidation. In humid areas, fuel and oil should be checked frequently and drained of condensed moisture.

11-82. **GROUND SERVICE RECEPTACLE.** With the ground service receptacle installed, the use of an external power source is recommended for cold weather starting and lengthy maintenance of the aircraft electrical system with the exception of electronic equipment.

### **NOTE**

Electrical power is supplied through a split bus bar, one side containing electronic system circuits and the other side having general electrical system circuits. In the split bus system, both sides of the bus are on at all times except when either an external power source is connected or the starter switch is turned on; then a power contactor is automatically activated to open the circuit to the electronic bus. Isolating the electronic circuits in this manner prevents harmful transient voltages from damaging the semiconductors in the electronic equipment.

The ground service plug receptacle circuit incorporates a polarity reversal protection. Power from the external power source will flow only if the ground service plug is correctly connected to the aircraft.







SECTION 11A

ENGINE

(ROLLS ROYCE/CONTINENTAL)

(THRU 1971)

1972 AND ON, REFER TO SECTION 11

TABLE OF CONTENTS

ENGINE COWLING . . . . .	11A-1	Carburetor . . . . .	11A-10
Description . . . . .	11A-1	Removal and Installation . . . . .	11A-10
Removal and Installation . . . . .	11A-1	Idle Speed and Mixture	
Cleaning and Inspection . . . . .	11A-1	Adjustments . . . . .	11A-10
Repair . . . . .	11A-1	Induction Air System . . . . .	11A-10
ENGINE . . . . .	11A-1	Description . . . . .	11A-10
Description . . . . .	11A-1	Airbox . . . . .	11A-11
Engine Data . . . . .	11A-2	Removal and Installation . . . . .	11A-11
Trouble Shooting . . . . .	11A-3	Ignition System . . . . .	11A-11
Removal . . . . .	11A-3	Description . . . . .	11A-11
Cleaning . . . . .	11A-3	Trouble Shooting . . . . .	11A-11
Accessories Removal . . . . .	11A-3	Magnetos . . . . .	11A-11
Inspection . . . . .	11A-3	Description . . . . .	11A-11
Build-Up . . . . .	11A-3	Removal and Installation . . . . .	11A-11
Installation . . . . .	11A-3	Internal Timing . . . . .	11A-11
Flexible Fluid Hoses . . . . .	11A-3	Magneto-to-Engine Timing . . . . .	11A-12
Leak Test . . . . .	11A-3	Maintenance . . . . .	11A-13
Replacement . . . . .	11A-3	Magneto Check . . . . .	11A-14
Static Run-Up Procedures . . . . .	11A-3	Spark Plugs . . . . .	11A-14
Engine Baffles . . . . .	11A-3	Engine Controls . . . . .	11A-14
Description . . . . .	11A-3	Description . . . . .	11A-14
Cleaning and Inspection . . . . .	11A-3	Rigging . . . . .	11A-14
Removal and Installation . . . . .	11A-3	Throttle Control . . . . .	11A-14
Repair . . . . .	11A-3	Mixture Control . . . . .	11A-14
Engine Mount . . . . .	11A-3	Carburetor Heat Control . . . . .	11A-14
Description . . . . .	11A-3	Starting System . . . . .	11A-14
Removal and Installation . . . . .	11A-3	Description . . . . .	11A-14
Repair . . . . .	11A-3	Trouble Shooting . . . . .	11A-14
Engine Shock-Mount Pads . . . . .	11A-3	Primary Maintenance . . . . .	11A-15
Engine Oil System . . . . .	11A-3	Starter Motor . . . . .	11A-15
Description . . . . .	11A-3	Removal and Installation . . . . .	11A-15
Trouble Shooting . . . . .	11A-6	Exhaust System . . . . .	11A-15
Full-Flow Oil Filter . . . . .	11A-7	Description . . . . .	11A-15
Description . . . . .	11A-7	Removal and Installation . . . . .	11A-15
Removal and Installation . . . . .	11A-7	Inspection . . . . .	11A-16
Filter Adapter . . . . .	11A-9	Extreme Weather Maintenance . . . . .	11A-16
Removal . . . . .	11A-9	Cold Weather . . . . .	11A-16
Disassembly, Inspection and		Hot Weather . . . . .	11A-16
Reassembly . . . . .	11A-9	Dusty Conditions . . . . .	11A-16
Installation . . . . .	11A-9	Seacoast and Humid Areas . . . . .	11A-16
Engine Fuel System . . . . .	11A-10	Ground Service Receptacle . . . . .	11A-16
Description . . . . .	11A-10	Hand Cranking . . . . .	11A-16

11A-1. ENGINE COWLING. Refer to paragraph 11-1.

11A-2. DESCRIPTION. Refer to paragraph 11-2.

11A-3. REMOVAL AND INSTALLATION. Refer to paragraph 11-3.

11A-4. CLEANING AND INSPECTION. Refer to paragraph 11-4.

11A-5. REPAIR. Refer to paragraph 11-5.

11A-6. ENGINE.

11A-7. DESCRIPTION. An air-cooled, wet-sump, horizontally-opposed, direct-drive, six-cylinder Continental O-300-D series engine is used to power the F172 aircraft through the 1971 model year. The cylinders, numbered from rear to front are staggered to permit a separate throw on the crankshaft for each connecting rod. The right rear cylinder is number 1 and cylinders on the right side are identified by odd numbers 1, 3 and 5. The left rear cylinder is number 2 and cylinders on the left side are identified by even numbers 2, 4 and 6. Refer to paragraph 11A-8 for detailed engine data. For repair and overhaul of the engine, accessories and propeller, refer to the applicable publications issued by their manufacturers.

11A-8. ENGINE DATA.

MODEL Rolls-Royce (Continental)	O-300-D
Rated Horsepower at RPM	145 at 2700
Number of Cylinders	6-Horizontally Opposed
Displacement	301.37
Bore	4.0625
Stroke	3.875
Compression Ratio	7.0:1
Magnetos	Slick No. 664
Right Magneto	Fires 26° BTC Upper Plugs
Left Magneto	Fires 28° BTC Lower Plugs
Firing Order	1-6-3-2-5-4
Spark Plugs	18 MM (Refer to Current Continental Active
Gap	Factory Approved Spark Plug Chart)
Torque	330 ± 30 Lb-In.
Carburetor (Marvel-Schebler)	MA-3-SPA
Oil Sump Capacity	8 U.S. Quarts
With External Filter	9 U.S. Quarts
Tachometer	Mechanical
Oil Pressure (psi)	
Minimum Idling	5
Normal	30-80
Maximum (Starting & Warm-Up)	100
Oil Temperature	
Normal Operating	Within Green Arc
Maximum	Red Line
Cylinder Head Temperature	
Normal Operating	Within Green Arc
Maximum	Red Line
Direction of Propeller Shaft Rotation (viewed from rear)	Clockwise
Dry Weight - With Accessories	298 lb (Weight is approximate and will vary with optional equipment installed.)

11A-9. TROUBLE SHOOTING. Refer to paragraph 11-9.

11A-10. REMOVAL. Refer to paragraph 11-10.

11A-11. CLEANING. Refer to paragraph 11-11.

11A-12. ACCESSORIES REMOVAL. Refer to paragraph 11-12.

11A-13. INSPECTION. Refer to paragraph 11-13.

11A-14. BUILD-UP. Refer to paragraph 11-14.

11A-15. INSTALLATION. Refer to paragraph 11-15 for engine installation procedures. Use figure 11A-1 as reference for shock-mount installation.

11A-16. FLEXIBLE FLUID HOSES. Refer to paragraph 11-16.

11A-17. LEAK TEST. Refer to paragraph 11-17.

11A-18. REPLACEMENT. Refer to paragraph 11-18.

11A-18A. STATIC RUN-UP PROCEDURES. In a case of suspected low engine power, a static RPM run-up should be conducted as follows:

a. Run-up engine, using take-off power and mixture settings, with the aircraft facing 90° right and then left to the wind direction.

b. Record the RPM obtained in each run-up position.

#### NOTE

Daily changes in atmospheric pressure, temperature and humidity will have a slight effect on static run-up.

c. Average the results of the RPM obtained on 1969 thru 1971 models should be within 50 RPM of 2280 RPM.

d. If the average results of the RPM obtained are lower than stated above, the following recommended checks may be performed to determine a possible deficiency.

1. Check carburetor heat control for proper rigging. If partially open it would cause a slight power loss.

2. Check magneto timing, spark plugs and ignition harness for settings and conditions.

3. Check condition of induction air filter. Clean if necessary.

4. Perform an engine compression check. (Refer to engine Manufacturer's Manual).

11A-19. ENGINE BAFFLES. Refer to paragraph 11-19.

11A-20. DESCRIPTION. Refer to paragraph 11-20.

11A-21. CLEANING AND INSPECTION. Refer to paragraph 11-21.

11A-22. REMOVAL AND INSTALLATION. Refer to paragraph 11-22.

11A-23. REPAIR. Refer to paragraph 11-23.

11A-24. ENGINE MOUNT. Refer to paragraph 11-24.

11A-25. DESCRIPTION. Refer to paragraph 11-25.

11A-26. REMOVAL AND INSTALLATION. Refer to paragraph 11-26.

11A-27. REPAIR. Refer to paragraph 11-27.

11A-28. ENGINE SHOCK-MOUNT PADS. Refer to paragraph 11-28.

11A-29. ENGINE OIL SYSTEM.

11A-30. DESCRIPTION. The engine lubricating system is of the full pressure, wet sump type. Oil is drawn from the sump through the suction screen in the lower left corner of the crankcase cover to the pump. From the pump, oil is delivered under pressure to the pressure screen where it is filtered and fed through drilled crankcase passages which supply oil to the crankshaft main bearings and drive bearings. Connecting rod bearings are pressure lubricated through internal passages in the crankshaft. Engine oil under pressure is carried through drilled passages to the hydraulic tappets. From the hydraulic tappets, pressure oil travels out through the hollow push rods and drilled rocker arms where it is spilled over the valve mechanism. Cylinder walls and piston pins are spray-lubricated by oil escaping from the connecting rod bearings. The pressure relief valve at the aft end of the right oil gallery regulates oil pressure by allowing excess oil to return to the sump. Residue oil from the bearings, accessory drives and rocker boxes flows by gravity to the sump where it passes through a suction screen and is recirculated through the engine. An external, replaceable element oil filter is available as optional equipment. This external filter replaces the pressure oil screen when installed.

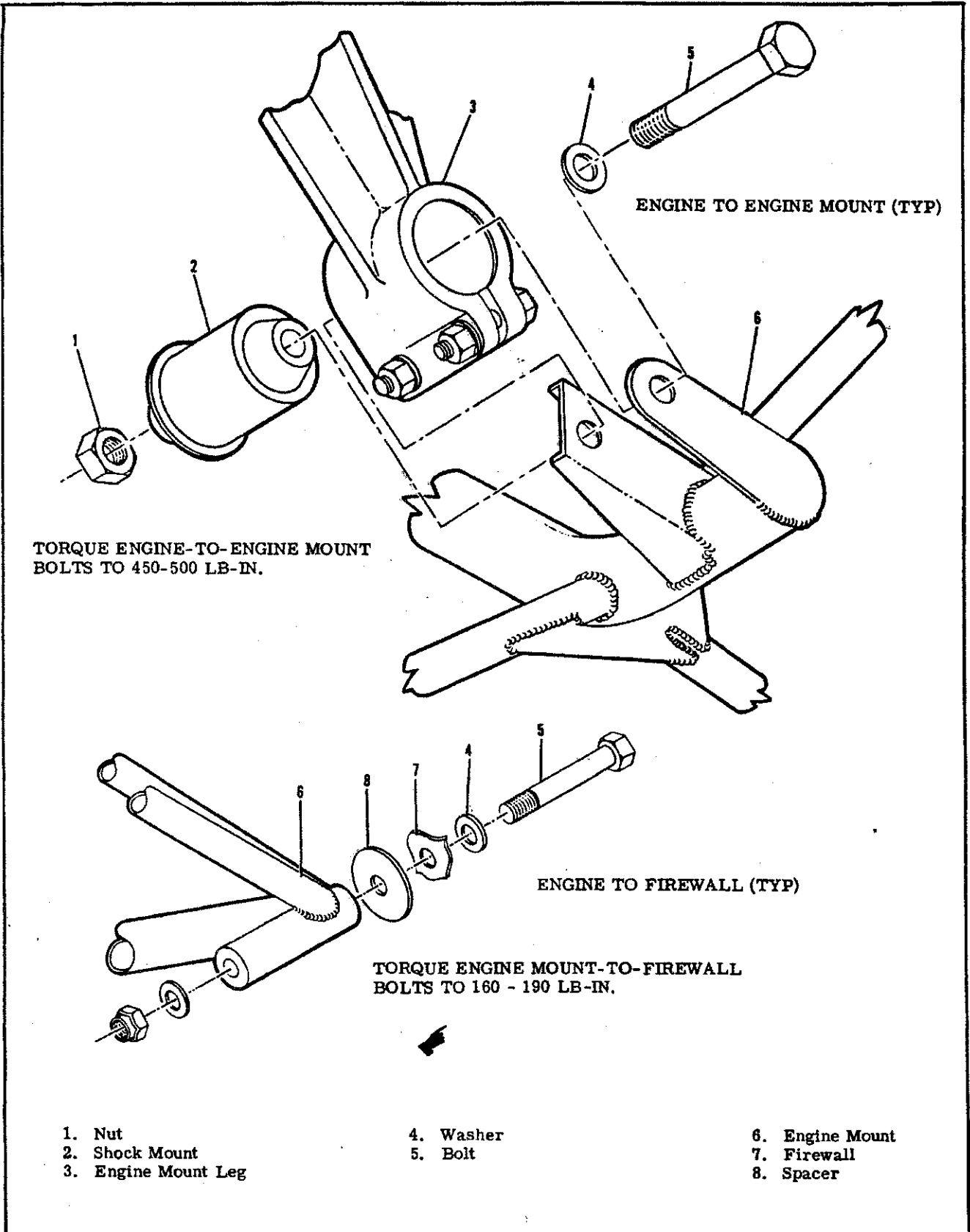



Figure 11A-1. Engine Mount Details

# CODE

-  PRESSURE OIL FROM GEAR TYPE OIL PUMP
-  SUMP OIL, SUCTION OIL, AND RETURN OIL FROM RELIEF VALVE

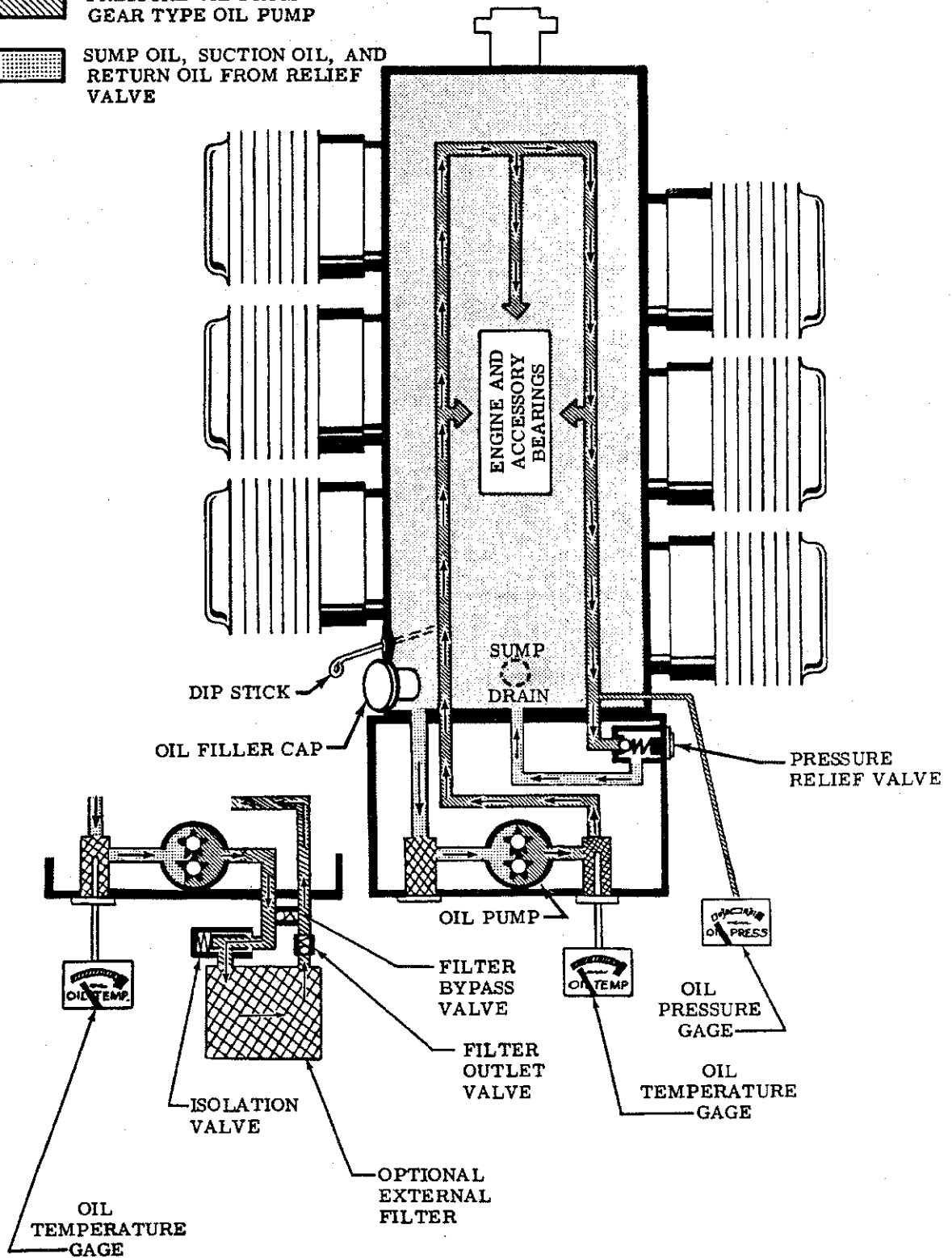

Figure 11A-2. Engine Oil Schematic

11A-31. TROUBLE SHOOTING.

TROUBLE	PROBABLE CAUSE	REMEDY
NO OIL PRESSURE.	No oil in sump.	Check with dipstick. Fill sump with proper grade and quantity of oil. Refer to Section 2.
	Oil pressure line broken, disconnected or pinched.	Inspect oil pressure line. Connect or replace line.
	Oil pump defective.	Remove and inspect. Examine engine. Metal particles from damaged pump may have entered engine oil passage.
	Defective oil pressure gage.	Check with a known good gage. If second reading is normal, replace gage.
	Oil congealed in gage line.	Disconnect line at engine and gage; flush with kerosene. Pre-fill line with kerosene and install.
	Pressure relief valve defective.	Remove and check for dirty or defective parts. Clean, replace defective parts and reinstall.
LOW OIL PRESSURE.	Low oil supply.	Check with dipstick. Fill sump with proper grade and quantity of oil. Refer to Section 2.
	Low oil viscosity.	Drain sump. Refill with correct grade and quantity of oil. Refer to Section 2.
	Plugged oil screen.	Inspect screen. Clean and re-install.
	Dirt on oil pressure relief valve seat or plunger sticking.	Remove, clean, replace defective parts and reinstall plunger and seat.
	Oil pressure gage defective.	Check with a known good gage. If second reading is normal, replace gage.
	Oil pump suction tube screen plugged or internal oil leak.	Engine overhaul required.

11A-31. TROUBLE SHOOTING (Cont).

TROUBLE	PROBABLE CAUSE	REMEDY
HIGH OIL PRESSURE.	High viscosity oil.	Drain sump. Refill with correct grade and quantity of oil. Refer to Section 2.
	Oil pressure gage defective.	Check with a known good gage. If second reading is normal, replace gage.
HIGH OIL TEMPERATURE.	Low oil supply.	Check with dipstick. Fill sump with proper grade and quantity of oil. Refer to Section 2.
	Dirty or diluted oil.	Check with dipstick. Drain sump and fill with proper grade and quantity of oil. Refer to Section 2.
	Prolonged ground operation at high engine speed.	Avoid prolonged running on the ground.
	Excessive rate of climb.	Avoid low airspeed.
	Lean fuel-air mixture.	Avoid excessive lean mixture operation.
	Oil temperature gage defective.	Check with a known good gage. If second reading is normal, replace gage.
	Winter baffles installed.	Check and remove winter baffles.
	Defective oil temperature bulb.	Check oil temperature gage with a known good gage. If second reading is the same, replace bulb.

11A-32. FULL-FLOW OIL FILTER. (Refer to figure 11A-3.)

11A-33. DESCRIPTION. An external oil filter may be installed on the engine. The filter and filter adapter replaces the regular internal oil pressure screen. In some filter installations, the filter adapter incorporates a bypass valve, outlet valve and isolation valve. Normally, oil from the oil pump flows through the isolation valve, through the filter element, through the outlet valve, to the engine oil passages. If the filter element should become blocked, the bypass valve and outlet valve will open, allowing pressure oil to flow to the engine oil passages. The isolation valve blocks off the filter assembly and oil then flows through the bypass valve, if excessive oil pressure should occur. In some filter installations the filter adapter incorporates only a bypass valve.

11A-34. REMOVAL AND INSTALLATION. (Refer to figure 11A-3.)

NOTE

New filter element kits are available from the Cessna Service Parts Center.

- a. Remove engine cowling in accordance with paragraph 11-3.
- b. Remove safety wires from filter can and unscrew hollow stud (1) to detach filter assembly from adapter (10) as a unit. Remove filter assembly from aircraft, discarding upper gasket (9). Oil will drain from filter as assembly is removed from adapter.
- c. Press downward on stud (1) to remove from filter element (5) and can (4). Discard metal gasket (2) on stud (1).
- d. Lift lid (7) from can (4) and discard lower gasket (6).
- e. Pull filter element (5) from can (4) and discard.

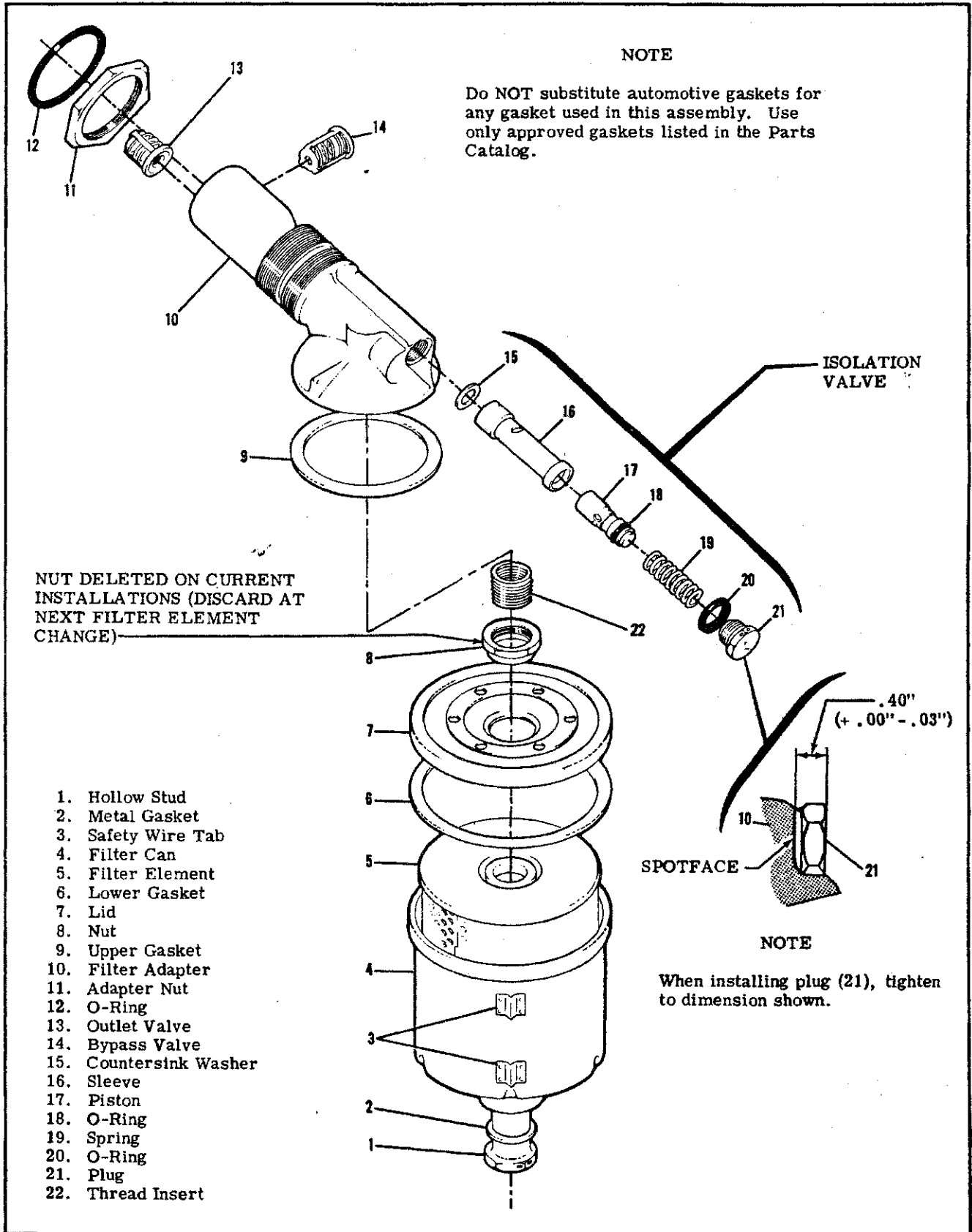

Figure 11A-3. Full-Flow Oil Filter



## NOTE

Before discarding removed filter element, remove the outer perforated paper cover; using a sharp knife, cut through the folds of the filter element at both ends. Then carefully unfold the pleated element and examine the material trapped in the filter element for evidence of internal engine damage such as chips or particles from bearings. In new or newly overhauled engines, some small particles or metallic shavings might be found. These are generally of no consequence and should not be confused with particles produced by impacting, abrasion or pressure. Evidence of internal engine damage found in the oil filter element justifies further examination to determine the cause.

- f. Wash lid (7), hollow stud (1) and can (4) in cleaning solvent and dry with compressed air.

## NOTES

When installing a new filter element, it is important that all gaskets are clean, lubricated and positioned properly, and that the correct amount of torque is applied to filter hollow stud. If the stud is under-torqued, oil leakage will occur. If the stud is over-torqued, the filter can may be deformed, again causing oil leakage.

- Lubricate rubber grommets in each end of new filter element, rubber gaskets (6 and 9) and metal gasket (2) with clean engine oil or general purpose grease before installation. Dry gaskets may cause false torque readings, again resulting in oil leakage.
  - Before assembly, place a straightedge across bottom of filter can. Check for a distortion or out-of-flat condition greater than .010 inch. Replace if either of these conditions exist.
  - Before assembly, cut adapter nut safety wire and try to rotate adapter by hand. If adapter can be moved, check for thread deformation in engine and adapter.
  - After installing a new gasket on lid (7), turn it upside down. If gasket falls, try a different gasket and repeat test. If this gasket falls off, install a new lid.
- g. Inspect adapter gasket seat for gouges, deep scratches, wrench marks and mutilation. If any of these conditions are found, install a new adapter.
  - h. Place new element in can and insert stud (1) with a new metal gasket (2) in place, through the can and element.
  - i. Position a new gasket (6) inside lower flange of lid (7). Position new gasket (9) around upper flange of lid (7). Place the lid in position.
  - j. Install filter assembly on adapter. Holding can to prevent it from turning, tighten stud (1) and torque to 20-25 lb-ft (240-300 lb-in), using a torque wrench.

k. Reinstall parts removed for access and service the engine with proper grade and quantity of oil. One additional quart of oil is required each time the element is replaced.

- l. Start engine and check for proper oil pressure. Check for oil leakage after warming up engine.
- m. Again check for oil leakage after engine has been run at a high power setting (preferably a flight around the field).
- n. Check to make sure that the filter has not been in contact with adjacent parts due to engine torque.
- o. While engine is still warm, recheck torque on stud (1), then safety stud to lower tab (3) on filter can and safety adapter to upper tab (3) on filter can.

## 11A-35. FILTER ADAPTER.

### 11A-36. REMOVAL. (Refer to figure 11A-3.)

- a. Remove filter assembly as outlined in paragraph 11A-34.
- b. Note angular position of adapter, then remove safety wire and loosen adapter nut (11).

## NOTE

A special wrench adapter for adapter nut (11) (Part No. SE-709) is available from the Cessna Service Parts Center, or one may be fabricated as shown in figure 11A-4. Remove any engine accessory that interferes with removal of the adapter.

- c. Unscrew adapter and remove from engine. Discard adapter O-ring.

11A-37. DISASSEMBLY, INSPECTION AND RE-ASSEMBLY. Figure 11A-3 shows the relative position of the internal parts of the filter adapter and may be used as a guide during installation of parts. The bypass and outlet valves are to be installed as complete units, with the valves being staked three places. The detail parts which form the isolation valve may be replaced individually. Also use new seals, lubricate parts with engine oil and replace any part that shows signs of excessive wear. Note that washer (15) is installed with its countersunk side toward outlet valve (13). Tighten plug (21) to a maximum of .40 inch as shown in figure 11A-3. The heli-coil type insert (22) in the adapter may be replaced, although special tools are required. Follow instructions of the tool manufacturer for their use. If the isolation valve should become defective, remove plug (21) and parts (15 through 20). Weld shut vent hole in plug (21). Reinstall washer (15), sleeve (16), O-ring (20) and plug (21) in the adapter. Inspect threads on adapter and in engine for damage. Clean adapter in solvent and dry with compressed air. Ascertain that all passages in the adapter are open and free of foreign material. Also, check that bypass and outlet valves are seated properly.

### 11A-38. INSTALLATION.

- a. Assemble adapter nut (11) and new O-ring (12) on adapter (10) in sequence illustrated in figure 11A-3.
- b. Lubricate O-ring on adapter with clean engine oil. Tighten adapter nut until O-ring is centered in

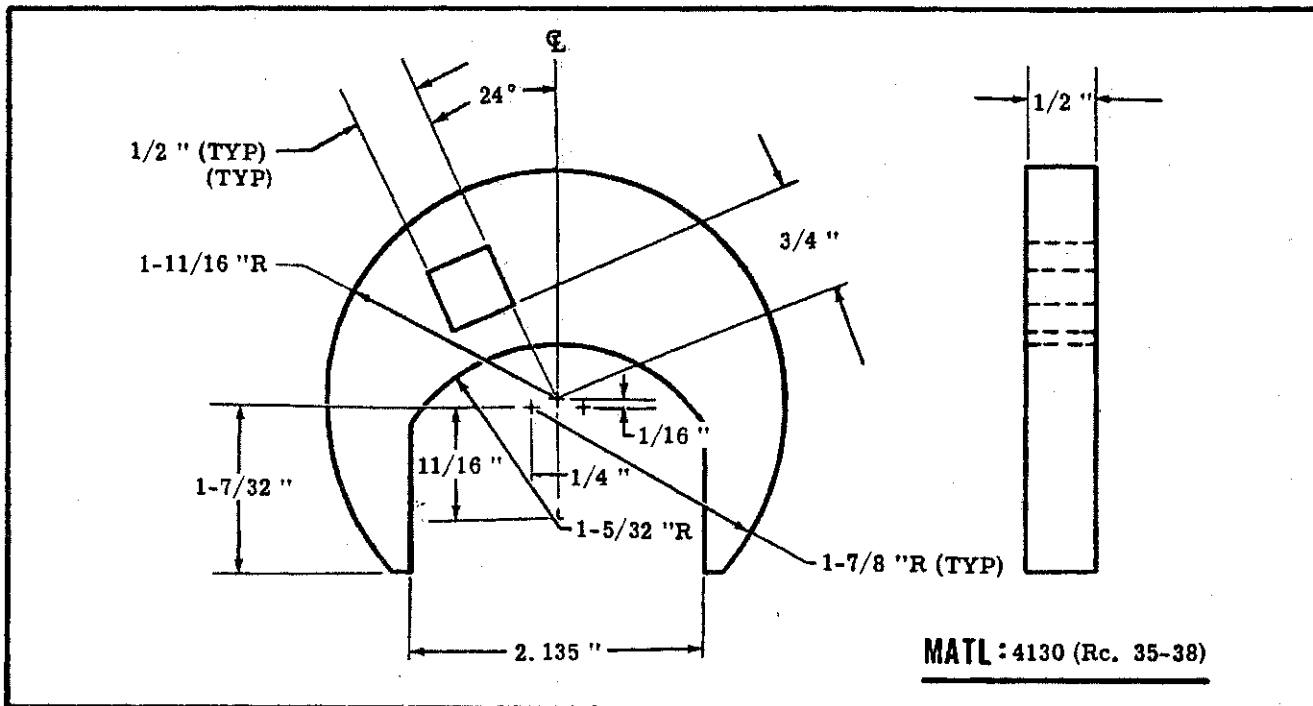

Figure 11A-4. Oil Filter Adapter Wrench Fabrication

its groove on the adapter.

c. Apply an anti-seize compound sparingly to the adapter threads, then simultaneously screw adapter and adapter nut into engine until O-ring seats against engine boss without turning adapter nut (11). Rotate adapter to approximate angular position noted during removal. Do not tighten adapter nut at this time.

d. Temporarily install filter assembly on adapter, and position so adequate clearance with adjacent parts is attained. Maintaining this position of the adapter, tighten adapter nut to 50-60 lb-ft (600-700 lb-in) and safety. Use a torque wrench, extension and adapter as necessary when tightening adapter nut.

e. Using new gaskets, install filter assembly as outlined in paragraph 11A-34. Be sure to service the engine oil system.

#### 11A-39. ENGINE FUEL SYSTEM.

11A-40. DESCRIPTION. The engine is equipped with a carburetor mounted at the lower side of the engine. The carburetor is of the plain-tube fixed-jet type and has such features as an enclosed accelerating pump mechanism, simplified fuel passages to prevent vapor locking, idle cut-off to prevent starting of the engine accidentally and manual mixture control for leaning. For overhaul and repair of the carburetor, refer to the manufacturer's overhaul and repair manual.

#### 11A-41. CARBURETOR.

##### 11A-42. REMOVAL AND INSTALLATION.

a. Place fuel selector valve in the OFF position.

b. Remove engine cowling in accordance with paragraph 11-3.

c. Drain fuel from strainer and lines with strainer drain control.

d. Remove airbox in accordance with paragraph 11A-47.

e. Disconnect throttle and mixture control to control arms on carburetor. Note EXACT position, size and number of washers and spacers for reference on reinstallation.

f. Disconnect and cap or plug fuel line at carburetor.

g. Remove nuts and washers attaching carburetor to intake manifold and remove carburetor and mounting gasket.

h. Reverse the preceding steps for reinstallation. Use new gasket when installing carburetor. Rig controls as outlined in paragraphs 11-64 and 11-65. Check carburetor throttle arm to idle stop arm attachment for security and proper safetying at each normal engine inspection in accordance with figure 11-5. The carburetor and linkage for the Continental engine will be different, but the method of safetying remains the same.

#### 11A-43. IDLE SPEED AND MIXTURE ADJUSTMENTS. Refer to paragraph 11-45.

#### 11A-44. INDUCTION AIR SYSTEM.

11A-45. DESCRIPTION. Ram air to the engine enters the induction airbox through the induction air filter located in the forward part of the lower engine cowling. From the induction airbox the air is directed to the inlet of the carburetor, mounted on the lower side of the engine, through the carburetor, where fuel is mixed with the air, to the intake manifold. From the intake manifold, the fuel-air mixture is distributed to each cylinder by separate intake pipes.

The intake pipes are attached to the intake manifold with hoses and clamps and to each cylinder with a gasket. The induction airbox contains a valve, operated by the carburetor heat control in the cabin, which permits air from an exhaust heated source to be selected in the event carburetor icing or filter icing should be encountered.

#### 11A-46. AIRBOX.

#### 11A-47. REMOVAL AND INSTALLATION.

- a. Remove cowling in accordance with paragraph 11-3.
- b. Disconnect flexible ducts from each side of airbox.
- c. Disconnect carburetor heat control at arm on airbox and remove clamp attaching control to airbox.
- d. Remove bolts attaching airbox to carburetor and screws attaching airbox to engine bracket.
- e. Reverse the preceding steps for reinstallation.

#### 11A-48. IGNITION SYSTEM.

11A-49. DESCRIPTION. The ignition system is comprised of two magnetos, two spark plugs in each cylinder, an ignition wiring harness, an ignition switch mounted on the instrument panel and required wiring between the ignition switch and magnetos.

11A-50. TROUBLE SHOOTING. Refer to paragraph 11-51. All reference to paragraph 11-58 for the Lycoming engine will be paragraph 11A-56 for the Continental engine.

#### 11A-51. MAGNETOS.

11A-52. DESCRIPTION. Engine ignition is supplied by two Slick magnetos (refer to paragraph 11A-8 for model number). The magnetos contain a conventional two-pole rotating magnet (rotor), mounted in ball bearings. Driven by the engine through an impulse coupling at one end, the rotor shaft operates the breaker points at the other end. The nylon rotor gear drives a nylon distributor gear which transfers high tension current from the wedge-mounted coil to the proper outlet in the distributor block. A coaxial capacitor is mounted in the distributor block housing to serve as the condenser as well as a radio noise suppressor. Both nylon gears are provided with timing marks for clockwise or counterclockwise rotation. The distributor gear and distributor block have timing marks, visible through the air vent holes, for timing to the engine. A timing hole is provided in the bottom of the magneto adjacent to the magneto flange. A timing pin or 6-penny nail can be inserted through this timing hole into the mating hole in the rotor shaft to lock the magneto approximately in the proper firing position. The breaker assembly is accessible after removing the screws fastening the magneto halves together and disconnecting the capacitor slip terminal.

#### NOTE

Thru aircraft F17200804, refer to Cessna Single-engine Service Letter SE74-21 for inspection of the impulse coupling pawl rivets.

#### 11A-53. REMOVAL AND INSTALLATION.

- a. Remove engine cowling in accordance with paragraph 11-3.
- b. Tag for identification and remove high tension wires from the magneto being removed.

#### WARNING

The magneto is not internally grounded when the switch wire is disconnected. Remove the high tension wires from magneto or disconnect spark plug leads from the spark plugs.

- c. Disconnect switch wire from condenser terminal at magneto. Tag wire for identification so it may be installed correctly.
- d. Rotate propeller in direction of normal rotation until No. 1 Cylinder is coming up on its compression stroke.

#### NOTE

To facilitate the installation of a replacement magneto, it is good practice to position for crankshaft at the advanced firing angle for No. 1 cylinder during step "d." Any standard timing device or method can be used, or if the magneto being removed is correctly timed to the engine, the crankshaft can be rotated to a position at which the breaker points will be just opening to fire No. 1 cylinder.

- e. Remove nuts and washers and pull magneto from crankcase mounting pad.

#### NOTE

For replacement of the breaker assembly or where removal of only the distributor half of the magneto is desired, remove the screws fastening the halves together, then pull the rear half aft only far enough to disconnect the capacitor slip terminal. As the halves are separated, be sure that the large distributor gear is not dropped.

#### CAUTION

When removing the distributor block housing from the engine half of magneto, do not pull it away far enough to break or damage the capacitor lead or slip terminal.

- f. Reverse the preceding steps for reinstallation and time magneto-to-engine in accordance with paragraph 11A-55.

#### 11A-54. INTERNAL TIMING.

- a. Whenever the gear on the rotor shaft or the cam (which also serves as the key for the gear) has been

removed, be sure that the gear and cam are installed so the timing mark on the gear aligns with the "O" etched on the rotor shaft.

b. When replacing breaker assembly or adjusting contact breaker points, place a timing pin (or 0.093 inch 6-penny nail) through the timing hole in the bottom of the magneto next to the flange and into the mating hole in the rotor shaft. Adjusting contact breaker points so they are just starting to open in this position will give the correct point setting. Temporarily assemble the magneto halves and capacitor slip terminal and use a timing light to check that the timing marks, visible through the ventilation plug holes are approximately aligned.

#### NOTE

The side of the magneto with the manufacturer's insignia has a red timing mark and the side opposite to the insignia has a black timing mark viewed through the vent plug holes. The distributor gear also has a red timing mark and a black timing mark. These marks are used for reference only when installing magneto on the engine. Do not place red and black lines together on the same side.

c. Whenever the large distributor gear and rotor gear have been disengaged, they must be engaged with their timing marks aligned for correct rotation. Align the timing mark on the rotor gear with the "RH" on the distributor gear. Care must be taken to keep these two gears meshed in this position until the magneto halves are assembled.

11A-55. MAGNETO-TO-ENGINE TIMING. The magneto must be installed with its timing marks correctly aligned and with the number one cylinder on its compression stroke with number one piston at its advanced firing position. Refer to paragraph 11A-8 for the advanced firing position of number one piston.

#### WARNING

The magneto is grounded through the magneto switch, therefore, any time the switch (primary) wire is disconnected from the magneto, the magneto is in a switch ON or HOT condition. Before turning the propeller by hand, remove the high tension wires from the magneto or disconnect all spark plug leads to prevent accidental firing of the engine.

To locate the compression stroke of number one cylinder, remove the lower spark plugs from each cylinder except number one cylinder. Remove the top plug from number one cylinder. Place thumb of one hand over the number one cylinder spark plug hole and rotate the crankshaft in the direction of normal rotation until the compression stroke is indicated by positive pressure inside the cylinder lifting the thumb off the spark plug hole. After the compression stroke is obtained, locate number one piston at its advanced firing position. Locating the advanced firing position

of number one cylinder may be obtained by rotating the crankshaft opposite to its normal direction of rotation until it is approximately 30 degrees before top center (BTC) on the compression stroke of number one cylinder. Then, rotate crankshaft in normal direction of rotation to align the correct timing mark on the outer surface of the crankshaft flange, with the parting surface of the crankcase below the crankshaft as the reference point, making sure the final motion of the crankshaft is in the direction of normal rotation.

#### NOTE

Various other methods and equipment may be used to arrive at the number one piston advanced firing position. One such method is: An accurate top center indicator which screws into a spark plug mounting hole and a pendulum pointer mounted on a 360-degree timing disc may be used. The timing disc should be adapted to fit over the end of the propeller spinner in such a manner that it may be rotated as necessary.

In all cases, it must be definitely determined that the number one cylinder is at the correct firing position, on the compression stroke, when the crankshaft is turned in its normal direction of rotation. After the engine has been placed in the correct firing position, install and time the magneto to the engine in the following manner.

a. Remove the timing (vent) plug from the bottom of the magneto. The vent plug in the top of the magneto need not be removed.

b. Turn the magneto shaft until the timing marks visible through the ventilation plug holes are aligned (red-to-red or black-to-black) and insert a timing pin (or 0.093 inch 6-penny nail) through the timing hole in the bottom of the magneto next to the flange and into the mating hole in the rotor shaft. This locks the magneto approximately in the firing position while installing on the engine.

c. Establish that the magneto is at number one firing position.

#### NOTE

Impulse coupling pawls must be depressed to turn magneto shaft in normal direction of rotation.

d. Keep timing mark centered in vent plug hole during installation.

e. Be sure magneto gaskets are in place and that engine is in correct firing position, then install magneto at the angle noted during removal, tighten mounting nuts finger tight.

#### CAUTION

Remove timing pin from magneto before turning the propeller.

f. Connect a timing light to the capacitor terminal at the rear of the magneto and to a good ground.

g. Turn propeller back a few degrees to close the contact points.

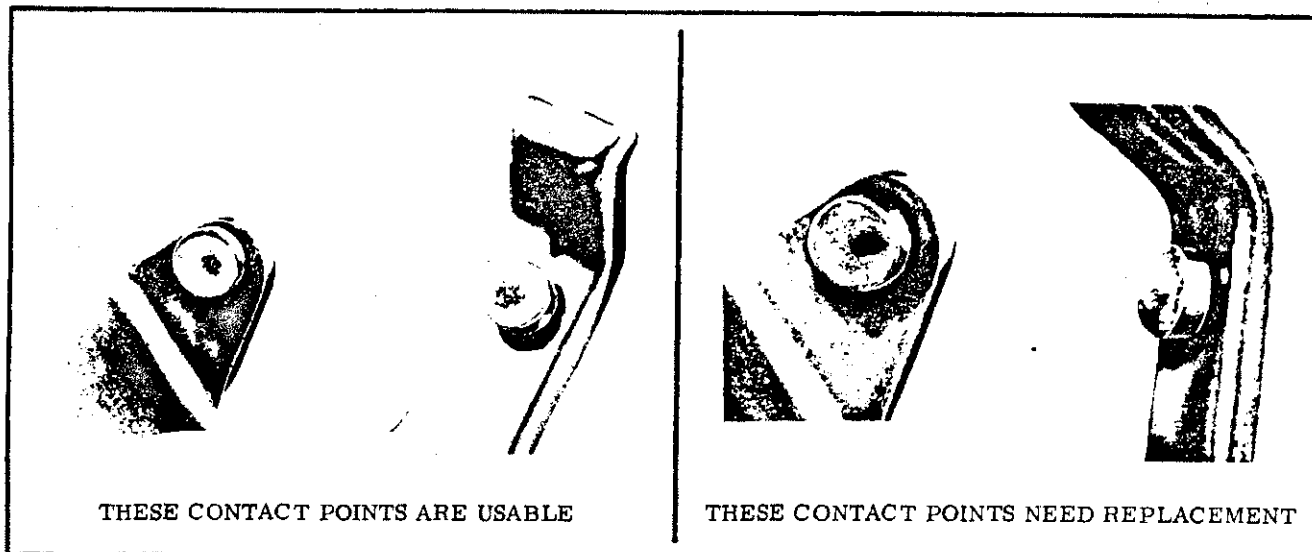

Figure 11A-5. Magneto Contact Breaker Points

**NOTE**

Do not turn the propeller back far enough to engage the impulse coupling or the propeller will have to be turned in normal direction of rotation until the impulse coupling releases, then backed up to slightly before the firing position.

h. Slowly advance propeller (tap forward with minute movements as firing position is approached) in normal direction of rotation until timing light indicates position at which contact points break. The contact points should break at the advanced firing position of number one cylinder. Loosen mounting nuts slightly and rotate magneto case to make contact points break at the correct position.

i. Tighten magneto mounting nuts, recheck timing.

j. Repeat steps "a" through "h" for the other magneto.

k. After both magnetos have been timed, check synchronization of both magnetos. Magnetos must fire at the same time.

l. Remove timing devices from magneto and engine.

m. Connect spark plug leads to their correct magneto outlets.

**NOTE**

Beginning with the number one outlet, the magneto fires at each successive outlet in a counterclockwise direction, looking at the outlets. Connect number one magneto outlet to number one cylinder spark plug lead, number two outlet to the next cylinder to fire, etc. Engine firing order is listed in paragraph 11A-8.

n. Connect switch primary lead to the capacitor terminal on the magneto.

o. Inspect magneto installation and install engine cowling in accordance with paragraph 11-3.

11A-56. MAINTENANCE. Magneto-to-engine timing should be checked with a timing light at each 100 hour inspection. Magneto-to-engine timing should be within a tolerance of plus zero, minus two degrees. In the event the magneto internal timing marks are off more than plus or minus five degrees when the breaker points open to fire number one cylinder, remove the magneto and check the magneto internal timing. Whenever the magneto halves are separated the breaker point assembly should always be checked. As long as internal timing and magneto-to-engine timing are within the preceding tolerances, it is recommended that the magneto be checked internally only at 500 hour intervals. It is normal for contact points to burn and the cam to wear a comparable amount so the magneto will remain in time within itself. This is accomplished by having a good area making contact on the surface between the points and the correct amount of spring pressure on the cam. The area on the points should be twenty-five percent of the area making contact. The spring pressure at the cam should be 10.5 to 12.5 ounces. When the contact points burn, the area becomes irregular, which is not detrimental to the operation of the points unless metal transfer is too great which will cause the engine to misfire. Figure 11A-5 illustrates good and bad contact points. A small dent will appear on the nylon insulator between the cam follower and the breaker bar. This is normal and does not require replacement.

**NOTE**

If ignition trouble should develop, spark plugs and ignition wiring should be checked first. If the trouble definitely is associated with a magneto, use the following to help disclose the source of trouble.

**a. Moisture Check.**

1. Remove magneto from engine and remove screws securing the magneto halves together, disconnect capacitor slip terminal, and remove distributor. Inspect for moisture.

2. Check distributor gear finger and carbon brush for moisture.

3. Check breaker point assembly for moisture, especially on the surfaces of the breaker points.

4. If any moisture is evident in the preceding places, wipe with a soft, dry, clean, lint-free cloth.

**b. Breaker compartment check.**

1. Check all parts of the breaker point assembly for security.

2. Check breaker point contact surfaces for evidence of excessive wear, burning, deep pits and carbon deposits. Breaker points may be cleaned with gasoline and hard-finish paper. If breaker point assembly is defective, install a new assembly. Make no attempt to stone or dress the breaker points. Clean new breaker points with clean, un-leaded gasoline and hard-finish paper before installing.

3. If the breaker point assembly is equipped with a cam oiler felt, inspect oiler felt, if dry, apply 2 or 3 drops of SAE 70 oil to felt. Remove any excess oil from breaker assembly. Too much oil will result in fouling and excessive burning of the breaker points. The corner of the felt should just barely touch the cam lobe. Newer breaker point assemblies are not equipped with the oiler felt. The cam lobe is lubricated with M-1827 Cam Grease.

4. Check capacitor mounting brackets for cracks or looseness.

5. Check carbon brush on distributor gear for excessive wear. The brush must extend a minimum of 1/32 inch beyond the end of the gear shaft. The spring which the carbon brush contacts should be bent out approximately 20 degrees from vertical, since spring pressure on the brush holds the distributor gear shaft against the thrust bearing in the distributor block.

6. Oil the bearings at each end of the distributor gear shaft with a drop of SAE 20 oil. Wipe excess oil from parts.

7. Make sure internal timing is correct and re-assemble magneto. Install and properly time magneto to engine.

11A-57. MAGNETO CHECK. Refer to paragraph 11-59.

11A-58. SPARK PLUGS. Refer to paragraph 11-60.

11A-59. ENGINE CONTROLS. Refer to paragraph 11-61.

11A-60. DESCRIPTION. Refer to paragraph 11-62.

11A-61. RIGGING. Refer to paragraph 11-63.

11A-62. THROTTLE CONTROL. Refer to paragraph 11-64.

11A-63. MIXTURE CONTROL. Refer to paragraph 11-65.

11A-64. CARBURETOR HEAT CONTROL. Refer to paragraph 11-66.

11A-65. STARTING SYSTEM.

11A-66. DESCRIPTION. The automatically engaged starting system employs an electric starter motor mounted to a 90-degree adapter. A starter solenoid is activated by the ignition key on the instrument panel. When the solenoid is activated, its contacts close and electrical current energizes the starter motor. Initial rotation of the starter motor engages the starter through an overrunning clutch in the starter adapter, which incorporates worm reduction gears. The starter is located just aft of the right rear cylinder.

**11A-67. TROUBLE SHOOTING.**

TROUBLE	PROBABLE CAUSE	REMEDY
STARTER WILL NOT OPERATE.	Defective master switch or circuit.	Check switch and circuit continuity. Replace switch or wiring as necessary.
	Defective starter switch or switch circuit.	Check switch and circuit continuity. Replace switch or wiring as required.
	Defective starter motor.	Check starter brushes, brush spring tension, thrown solder on brush cover, worn, or dirty commutator. Repair or replace starter motor.

11A-67. TROUBLE SHOOTING (Cont).

TROUBLE	PROBABLE CAUSE	REMEDY
STARTER MOTOR RUNS, BUT DOES NOT TURN CRANK-SHAFT.	Defective overrunning clutch or drive.	Remove and inspect starter and adapter, replace defective parts.
	Damaged starter pinion gear or crankshaft gear.	Remove, inspect and replace defective parts.
STARTER DRAGS.	Low battery.	Check battery. Charge or replace battery.
	Starter switch or relay contacts burned or dirty.	Replace with serviceable parts.
	Defective starter power cable.	Check cable. Replace power cable.
	Defective starter motor.	Check starter brushes, brush spring tension, thrown solder on brush cover, worn, or dirty commutator. Repair or replace starter motor.
STARTER EXCESSIVELY NOISY.	Worn starter pinion gear.	Remove and inspect pinion. Replace starter drive.
	Worn or broken teeth on crankshaft gears.	Remove starter and inspect crankshaft gear. Replace parts as necessary.

11A-68. PRIMARY MAINTENANCE. Refer to paragraph 11-70.

11A-69. STARTER MOTOR.

11A-70. REMOVAL AND INSTALLATION-

a. Remove engine cowling in accordance with paragraph 11-3.

**CAUTION**

When disconnecting or connecting the starter cable, do not permit starter terminal bolt to rotate. Rotation of the bolt could break the conductor between terminal and field coils causing the starter to be inoperative.

- b. Disconnect electrical cable at starter motor. Insulate the disconnected cable terminal as a safety precaution.
- c. Remove the nuts securing starter motor to adapter and remove starter.
- d. Reverse the preceding steps for reinstallation. Install a new O-ring on the starter, then install the starter. Be sure that starter engages with the drive in the adapter.

11A-71. EXHAUST SYSTEM.

11A-72. DESCRIPTION. The exhaust system consists of two exhaust stack assemblies, one for the left and one for the right bank of cylinders. Each cylinder has a riser pipe attached to the exhaust port. The three risers at each bank of cylinders are attached to a muffler and tailpipe forming an exhaust stack assembly. The mufflers are enclosed in shrouds which capture exhaust heat for cabin and carburetor heating.

11A-73. REMOVAL AND INSTALLATION.

- a. Remove engine cowling in accordance with paragraph 11-3.
- b. Disconnect flexible ducts from shrouds on mufflers.
- c. Disconnect braces from tailpipes.
- d. Remove hardware attaching riser pipes to mufflers.
- e. Loosen nuts attaching riser pipes to cylinders and remove mufflers.
- f. Remove nuts and washers attaching riser pipes to cylinders and remove pipes and gaskets.
- g. Reverse the preceding steps for reinstallation. Use a new copper-asbestos gasket between each exhaust riser and its mounting pad on the cylinder.





SECTION 12

FUEL SYSTEM

TABLE OF CONTENTS

	Page		
FUEL SYSTEM . . . . .	12-1	Checking . . . . .	12-9
Description . . . . .	12-1	Fuel Selector Valve . . . . .	12-9
Precautions . . . . .	12-1	Description . . . . .	12-9
Trouble Shooting . . . . .	12-2	Removal and Installation . . . . .	12-9
Fuel Tanks . . . . .	12-8	Fuel Strainer . . . . .	12-9
Description . . . . .	12-8	Description . . . . .	12-9
Removal and Installation . . . . .	12-8	Removal and Installation . . . . .	12-9
Fuel Quantity Transmitters . . . . .	12-8	Disassembly and Assembly . . . . .	12-9
Fuel Vents . . . . .	12-8	Priming System . . . . .	12-10
Description . . . . .	12-8	Description . . . . .	12-10
		Removal and Installation . . . . .	12-10

12-1. FUEL SYSTEM.

12-2. DESCRIPTION. Fuel is gravity-fed from a metal tank in the inboard section of each wing, through a selector valve and a fuel strainer, to the carburetor. Positive ventilation is provided by a vent line and check valve assembly located in the left wing tank and a crossover vent line connecting the two tanks together. The vent line from the check valve assembly extends overboard through the lower wing skin adjacent to the left wing strut. The strainer is equipped with a quick-drain valve which provides a means of draining trapped water and sediment from the fuel system.

12-3. PRECAUTIONS.

NOTE

There are certain general precautions and rules concerning the fuel system which should be observed when performing the operations and procedures in this section. These are as follows:

- a. During all fueling, defueling, tank purging, and

tank repairing or disassembly, ground the aircraft to a suitable ground stake.

- b. Residual fuel draining from lines and hose constitutes a fire hazard. Use caution to prevent the accumulation of fuel when lines or hose are disconnected.

- c. Cap open lines and cover connections to prevent thread damage and the entrance of foreign matter.

NOTE

Throughout the aircraft fuel system, from the fuel tanks to the carburetor, use NS-40 (RAS-4) (Snap-On Tools Corp., Kenosha, Wisconsin), MIL-T-5544 (Thread Compound Antiseize, Graphite Petrolatum), USP Petrolatum or engine oil as a thread lubricator or to seal a leaking connection. Apply sparingly to male threads only, omitting the first two threads, exercising extreme caution to avoid "stringing" sealer across the end of the fitting. Always ensure that a compound, the residue from a previously used compound, or any other foreign material cannot enter the system.

12-4. TROUBLE SHOOTING.

TROUBLE	PROBABLE CAUSE	REMEDY
NO FUEL TO CARBURETOR.	Fuel selector valve not turned on.	Turn valve on.
	Fuel tanks empty.	Service with proper grade and amount of fuel.
	Fuel line disconnected or broken.	Connect or repair fuel lines.
	Inlet elbow or inlet screen in carburetor plugged.	Clean and/or replace.
	Fuel tank outlet strainers plugged.	Remove and clean strainers and flush out fuel tanks.
	Defective fuel selector valve.	Repair or replace selector valve.
	Plugged fuel strainer.	Remove and clean strainer and screen.
	Fuel line plugged.	Clean out or replace fuel line.
FUEL STARVATION AFTER STARTING.	Partial fuel flow from the preceding causes.	Use the preceding remedies.
	Plugged fuel vent.	See paragraph 12-13.
	Water in fuel.	Drain fuel tank sumps, fuel lines and fuel strainer.
NO FUEL QUANTITY INDICATION.	Open circuit.	Reset circuit breaker. Refer to Section 15.
	Fuel tanks empty.	Service with proper grade and amount of fuel.
	Loose connections or open circuit.	Tighten connections; repair or replace wiring. Refer to Section 20.
	Defective fuel quantity indicator or transmitter.	Refer to Section 15.
PRESSURIZED FUEL TANK.	Plugged bleed hole in fuel vent.	Check per paragraph 12-13.

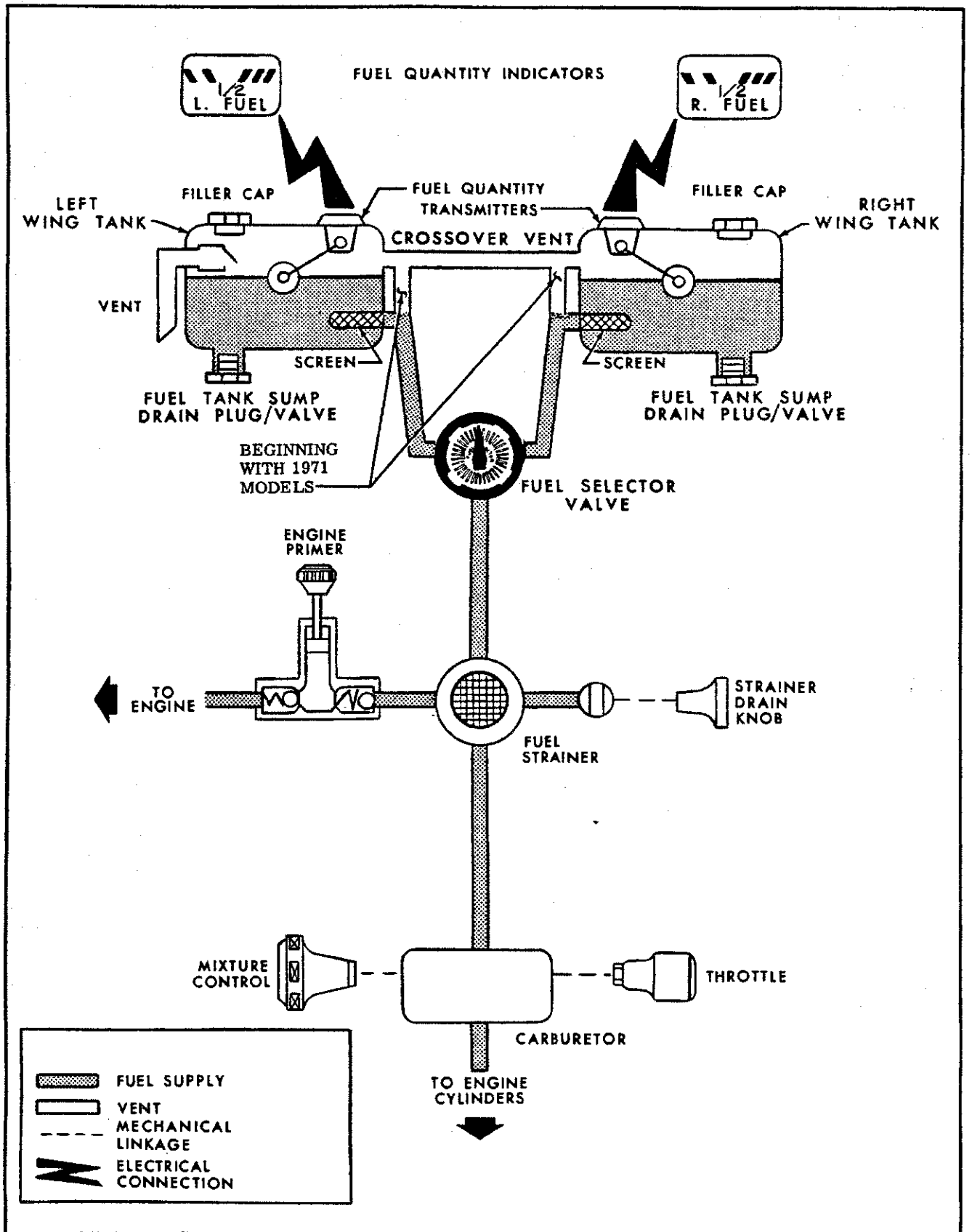

Figure 12-1. Fuel System Schematic

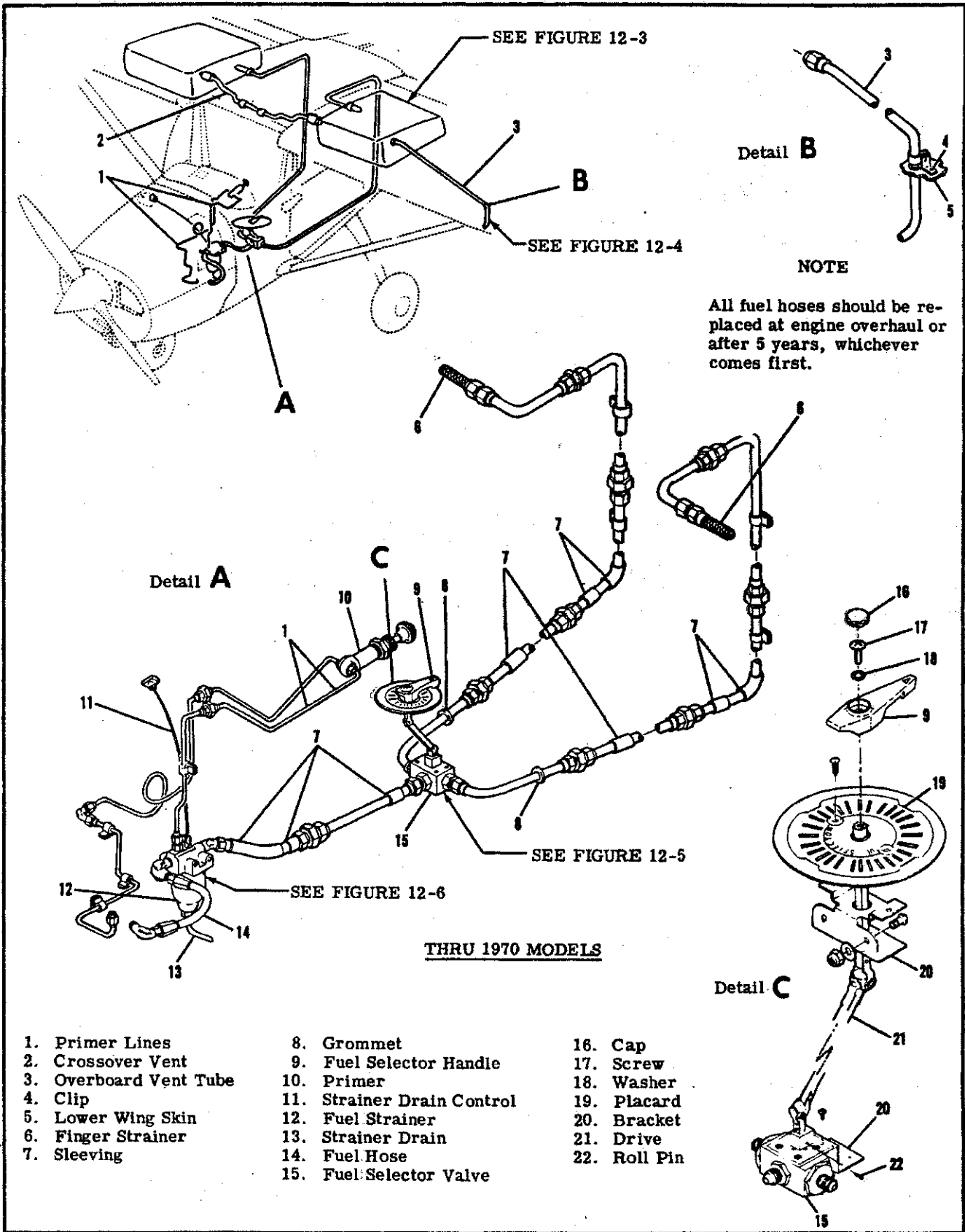

Figure 12-2. Fuel System (Sheet 1 of 2)

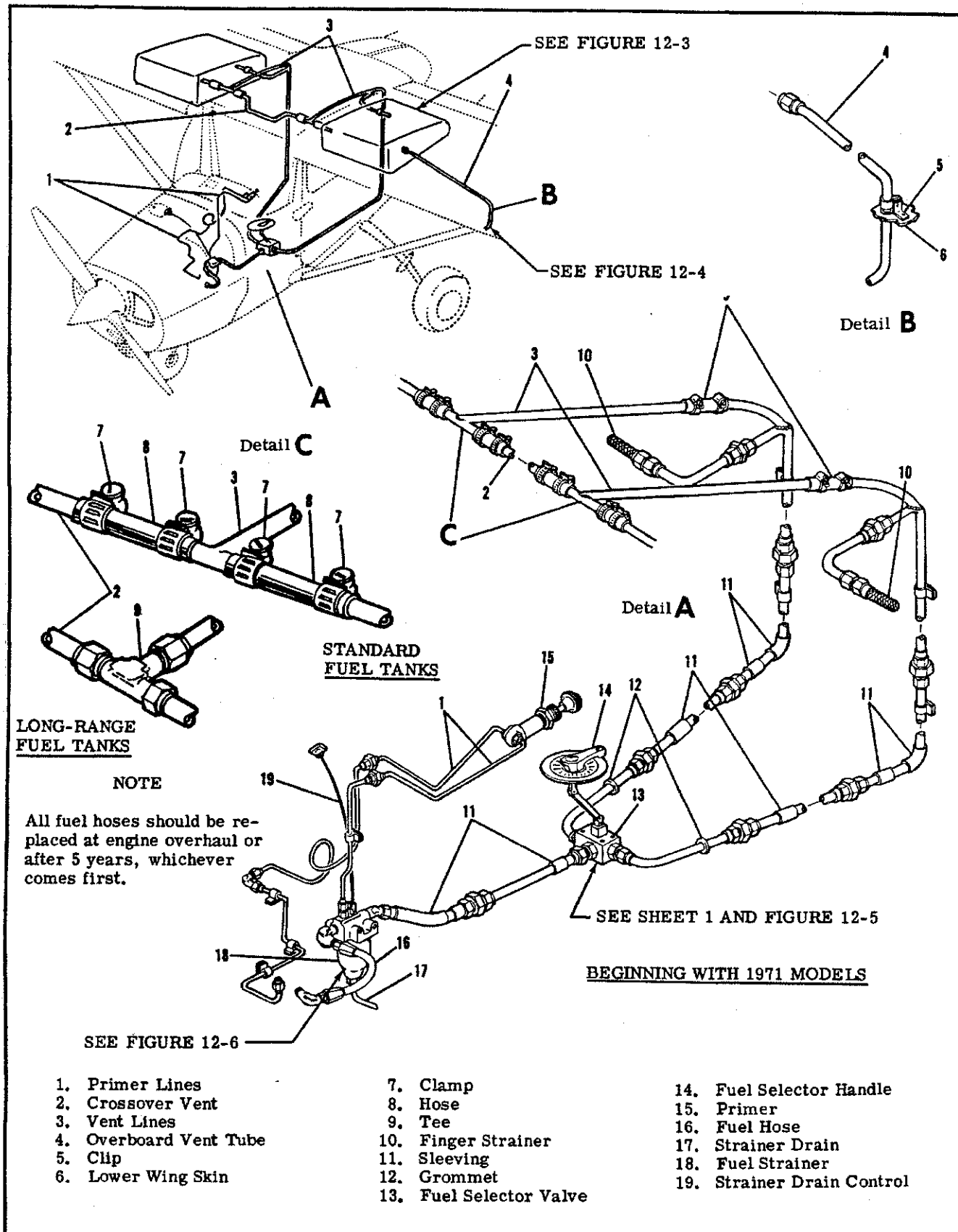

Figure 12-2. Fuel System (Sheet 2 of 2)

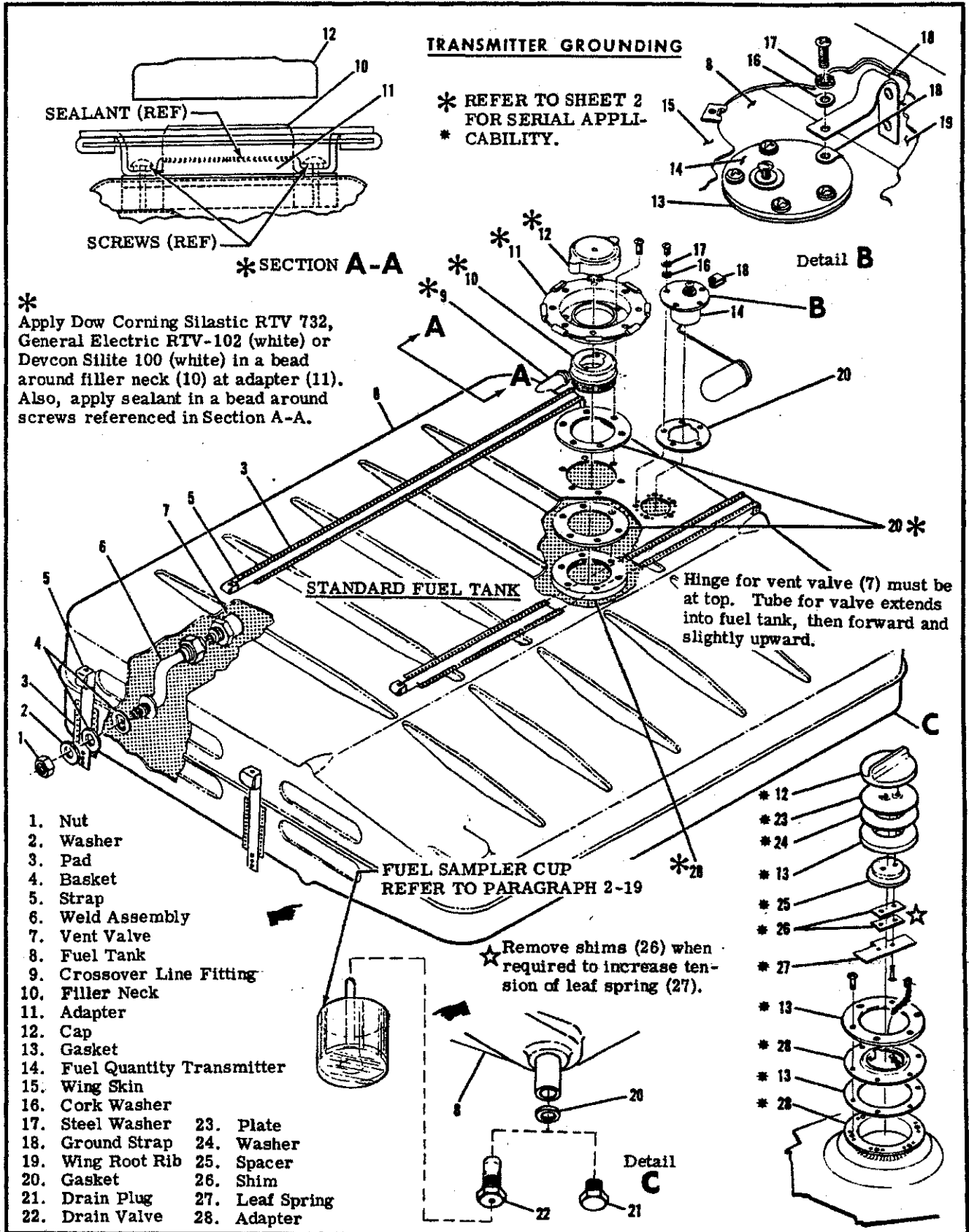

Figure 12-3. Fuel Tank (Sheet 1 of 2)

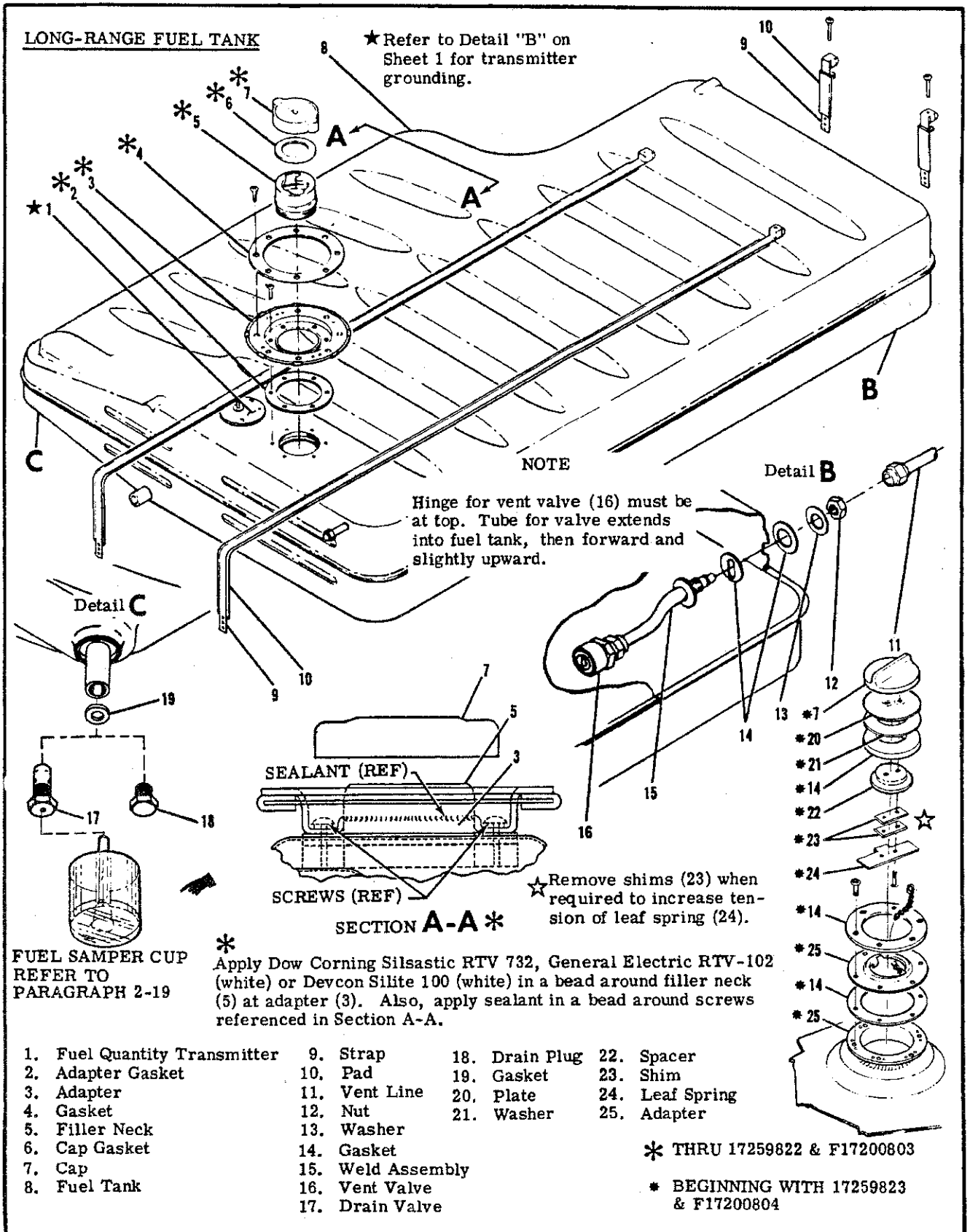

Figure 12-3. Fuel Tank (Sheet 2 of 2)

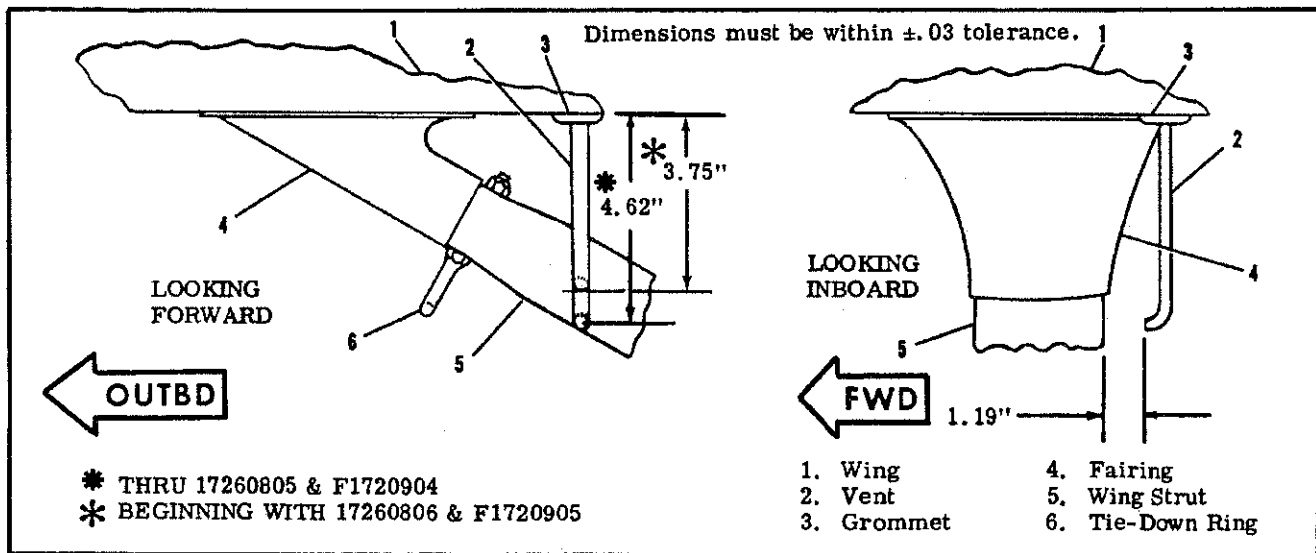

Figure 12-4. Fuel Vent Location

#### 12-5. FUEL TANKS.

12-6. DESCRIPTION. A rigid metal tank is installed in the inboard panel of each wing. Sump drain plugs or valves, one in each tank, are provided for draining trapped water and sediment.

#### 12-7. REMOVAL AND INSTALLATION.

- a. Remove sump drain plug or valve and drain fuel from applicable tank. (Observe precautions in paragraph 12-3.)
- b. Remove fuel tank cover by removing attaching screws.
- c. Remove wing root fairings.
- d. Disconnect and plug or cap all fuel and vent lines from tank. Remove fittings as necessary for clearance when removing tank.
- e. Disconnect electrical lead and ground strap from fuel quantity transmitter.
- f. Disconnect straps securing fuel tank and remove tank. Use care to avoid damage to protruding fittings and hose connections when removing the tank.
- g. To install tank, reverse the preceding steps. Be sure grounding is secure in accordance with figure 12-3.

12-8. FUEL QUANTITY TRANSMITTERS. Fuel quantity transmitters are installed in the top of fuel

tanks. A complete description, along with procedures for removal, installation and adjustment are contained in Section 15.

#### 12-9. FUEL VENTS.

12-10. DESCRIPTION. A vent line is installed in the outboard end of the left fuel tank and extends overboard down through the lower wing skin. The inboard end of the vent line extends into the fuel tank, then forward and slightly upward. A vent valve is installed on the inboard end of the vent line inside the fuel tank. A crossover line connects the two tanks together. Beginning with 1971 Models, a tee is installed on each end of the crossover line. A separate vent line is attached to the tees, connecting the crossover line to each of the fuel supply lines from each fuel tank. Refer to figure 12-2 for line routing.

12-11. CHECKING. Field experience has demonstrated that the fuel vent can become plugged, with possible fuel starvation of the engine or collapse of the fuel tanks. Also, the bleed hole in the vent valve assembly could possibly become plugged, allowing pressure from expanding fuel to pressurize the tanks. The following procedure may be used to check the vent and bleed hole in the valve assembly.

## SHOP NOTES:



- a. Attach a rubber tube to the end of vent line beneath the wing.
- b. Blow into tube to slightly pressurize tank. If air can be blown into tank, vent line is open.
- c. After tank is slightly pressurized, insert end of rubber tube into a container of water and watch for a continuous stream of bubbles, which indicates the bleed hole in valve assembly is open and relieving pressure.
- d. After completion of step "c", blow into tube again to slightly pressurize the tank, and loosen, but do not remove filler cap on opposite wing to check tank crossover line. If pressure escapes from filler cap, crossover line is open.

**NOTE**

Remember that a plugged vent line or bleed hole can cause either fuel starvation and collapsing of fuel tanks or the pressurization of tanks by fuel expansion.

- e. Any fuel vent found plugged or restricted must be corrected prior to returning aircraft to service.

**NOTE**

The fuel vent line protruding beneath the wing near the wing strut must be correctly aligned to avoid possible icing of the vent tube. Dimensions are shown in figure 12-4.

**12-12. FUEL SELECTOR VALVE.**

**12-13. DESCRIPTION.** A four position fuel selector valve is located between the pilot and copilot positions on the pedestal. The positions on the valve are labeled "OFF, LEFT, BOTH ON and RIGHT." Valve repair consists of replacement of seals, springs, balls and other detail parts. Figure 12-5 illustrates the proper relationship of parts and may be used as a guide during disassembly and assembly.

**12-14. REMOVAL AND INSTALLATION.** (See figure 12-2.)

- a. Completely drain all fuel from wing tanks, fuel strainer, lines and selector valve. (Observe precautions in paragraph 12-3.)
- b. Remove selector valve handle.
- c. Remove pedestal cover.
- d. Remove carpeting as necessary to gain access to plates aft of pedestal.
- e. Disconnect handle drive shaft from valve.
- f. Disconnect and cap or plug all fuel lines at valve.
- g. Remove screws attaching valve to bracket and remove valve.

- h. Reverse the preceding steps for installation. Prior to installing access plates, service fuel tanks and check for leaks.

**12-15. FUEL STRAINER.** (See figure 12-6.)

**12-16. DESCRIPTION.** The fuel strainer is mounted at the firewall in the lower engine compartment. The strainer is equipped with a quick-drain valve which provides a means of draining trapped water and sediment from the fuel system. The quick-drain control is located adjacent to the oil dipstick and is accessible through the oil dipstick door in the upper engine cowl.

**NOTE**

The fuel strainer can be disassembled, cleaned and reassembled without removing the assembly from the aircraft. (Refer to paragraph 12-18.)

**12-17. REMOVAL AND INSTALLATION.** (See figure 12-6.)

- a. Remove cowling as necessary to gain access to strainer.
- b. With selector valve in "OFF" position, drain fuel from strainer and lines with strainer quick-drain control.
- c. Disconnect and cap or plug all fuel lines and controls from strainer. (Observe precautions in paragraph 12-3.)
- d. Remove bolts attaching assembly to firewall and remove strainer.
- e. Reverse the preceding steps for installation. With selector valve in "ON" position check for leaks and proper operation of quick-drain valve.

**12-18. DISASSEMBLY AND ASSEMBLY.** (See figure 12-6.)

- a. With selector valve in "OFF" position, drain fuel from bowl and lines with quick-drain control.
- b. Remove drain tube, safety wire, nut and washer at bottom of filter bowl and remove bowl.
- c. Carefully unscrew standpipe and remove.
- d. Remove filter screen and gasket. Wash filter screen and bowl with solvent (Federal Specification P-S-661, or equivalent) and dry with compressed air.
- e. Using a new gasket between filter screen and top assembly, install screen and standpipe. Tighten standpipe only finger tight.
- f. Using all new O-rings, install bowl. Note that step-washer at bottom of bowl is installed so that step seats against O-ring. Connect drain tube.
- g. With selector valve in "ON" position, check for leaks and proper operation of quick-drain valve.
- h. Safety wire bottom nut to top assembly. Wire must have right hand wrap, at least 45 degrees.

**SHOP NOTES:**

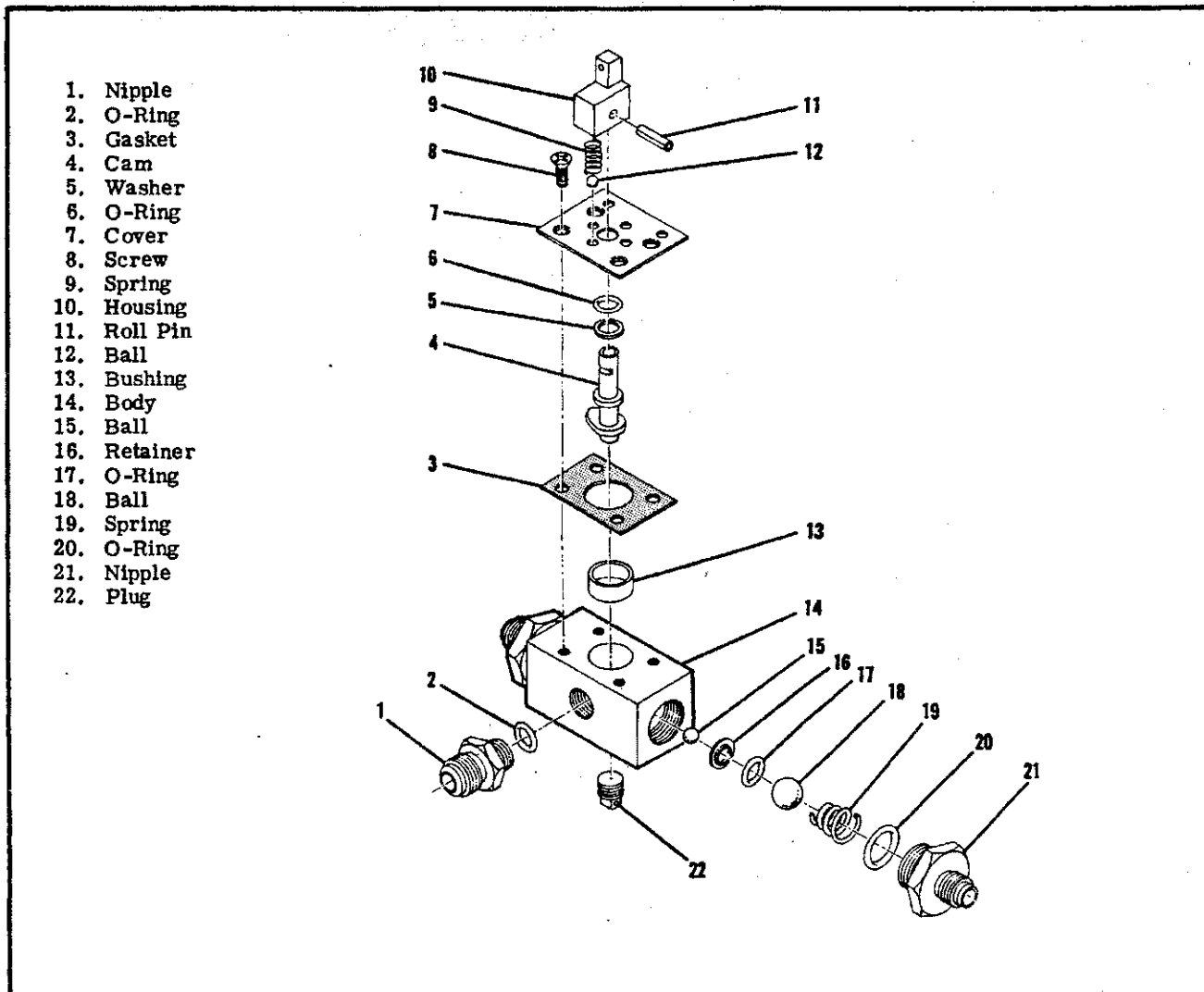

Figure 12-5. Fuel Selector Valve

12-19. PRIMING SYSTEM. (See figure 12-2.)

12-20. DESCRIPTION. The model 172-Series, equipped with a "Blue Streak" (Lycoming) engine, employs a standard manually-operated priming system which primes one cylinder. Fuel is supplied by a line from the strainer to the plunger-type primer. Operating the primer delivers fuel to the intake port of the cylinder. A three-cylinder priming system is available as optional equipment. Operating the primer on this optional system delivers fuel to the intake port of each individual cylinder except No. 3. The F172-Series, equipped with the O-300-D Continental engine, manufactured under license by Rolls Royce, employs a standard manually-operated primer system. Operating the primer delivers fuel to the right-hand side of the intake manifold just above the carburetor.

12-21. REMOVAL AND INSTALLATION.

- a. Disconnect and cap all lines from primer.
- b. Unscrew knurled nut and remove plunger from pump body.
- c. Remove pump body from instrument panel.

NOTE

Visually inspect primer lines for crushed, kinked, or broken condition. Ensure proper clamping to prevent fatigue due to vibration and chafing.

- d. Prior to installing a primer, check for proper pumping action and positive fuel shut-off in the locked position.
- e. Reverse preceding steps for installation.

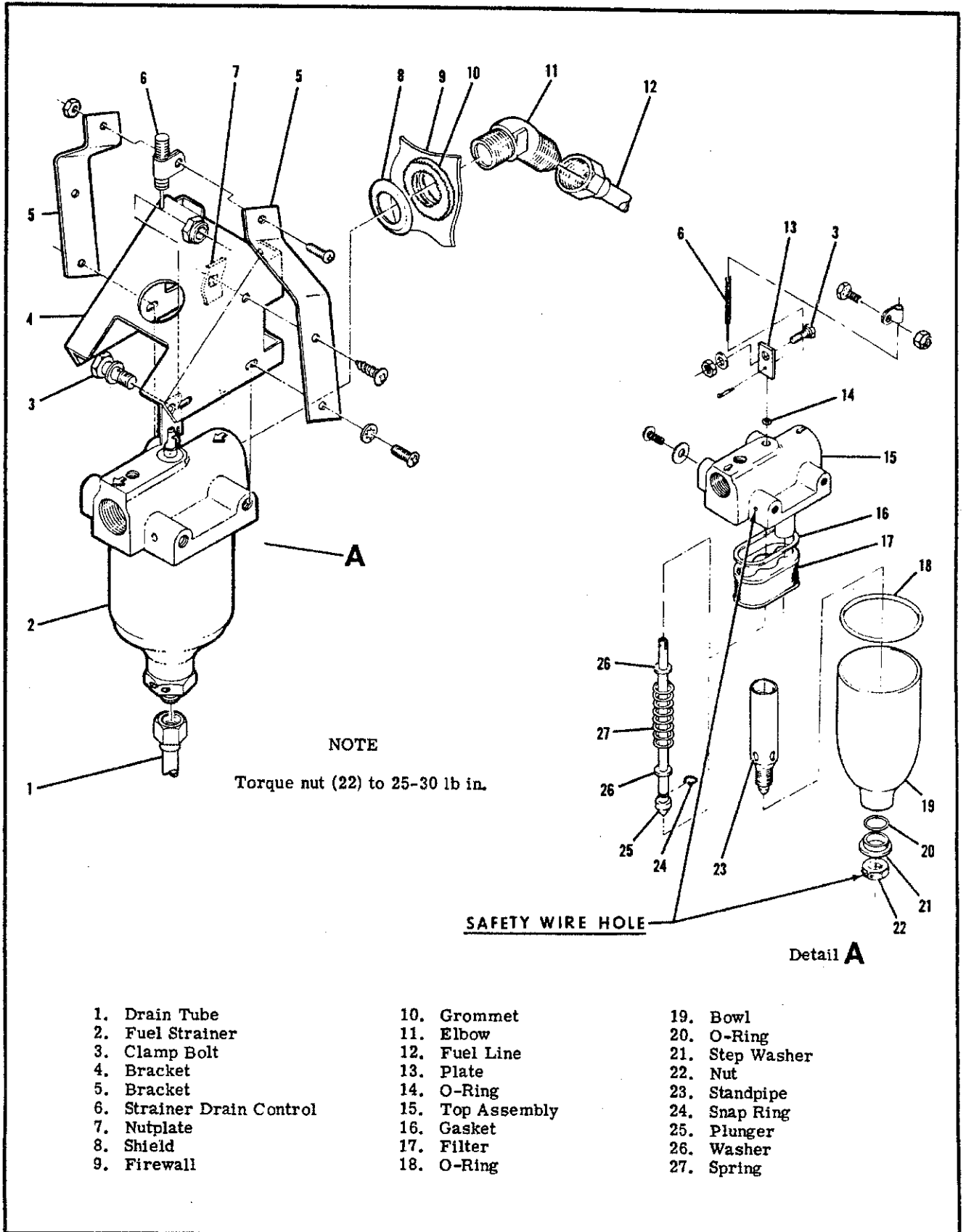

Figure 12-6. Fuel Strainer



SECTION 13  
PROPELLER

TABLE OF CONTENTS

	Page
PROPELLER . . . . .	13-1
Description . . . . .	13-1
Repair . . . . .	13-1
Removal (Lycoming Engines) . . . . .	13-1
Installation (Lycoming Engines) . . . . .	13-1
Removal (Continental Engines) . . . . .	13-3
Installation (Continental Engines) . . . . .	13-3

13-1. PROPELLER.

13-2. DESCRIPTION. An all-metal, fixed-pitch propeller, equipped with a spinner, is used on the aircraft. Refer to figures 13-1 and 13-2 for the different installations of the propeller and spinners.

13-3. REPAIR. Repair of a metal propeller first involves evaluating the damage and determining whether the repair is to be a major or minor one. Federal Aviation Regulations, Part 43 (FAR 43) and Federal Aviation Agency Advisory Circular No. 43.13 (FAA AC No. 43.13), define major and minor repairs, alterations and who may accomplish them. When making alterations or repairs to a propeller, FAR 43, FAA AC 43.13 and the propeller manufacturer's instructions must be observed. The propeller manufacturer's Service Manual may be obtained from the Cessna Service Parts Center.

13-4. REMOVAL (LYCOMING ENGINES). (Refer to figure 13-1.)

**WARNING**

Be sure magneto switch is in OFF position before turning propeller.

- a. Remove spinner (1).
- b. Remove mounting bolts (2) and remove forward spinner bulkhead (3), propeller (4), rear spinner bulkhead (9) and spacer (8).

- c. If removal of the ring gear support assembly (7) is necessary, loosen the alternator adjusting arm and disengage the drive pulley belt from pulley on the aft face of the starter ring gear support assembly.

13-5. INSTALLATION (LYCOMING ENGINES). (Refer to figure 13-1.)

**WARNING**

Be sure magneto switch is in OFF position before turning propeller.

- a. If the starter ring gear support assembly (7) was removed, clean the mating surface of support assembly and engine crankshaft.
- b. Place alternator drive belt in the pulley groove of the starter ring gear support. Fit support assembly over propeller flange bushing of the crankshaft.

NOTE

Make sure the bushing hole in the ring gear support that bears the identification "O," is assembled at the "O" identified crankshaft flange bushing. This bushing is marked "O" by an etching on the crankshaft flange next to the bushing. The starter ring gear must be located correctly to assure proper alignment of the timing marks on the ring gear.

**NOTE**

**TORQUE PROPELLER MOUNTING BOLTS TO 540 - 560 LB-IN OR 45 - 46.5 LB-FT AND SAFETY WIRE**

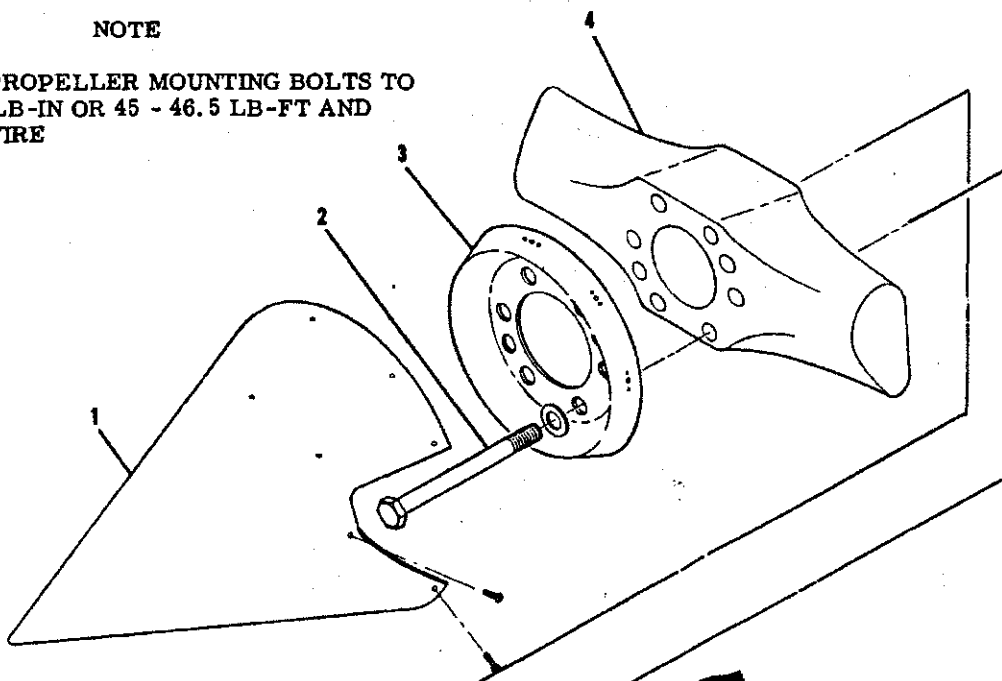

- \* STANDARD BEGINNING WITH 17261899 & F17201035
- \* ALTERNATE BEGINNING WITH 17261899 & F17201035

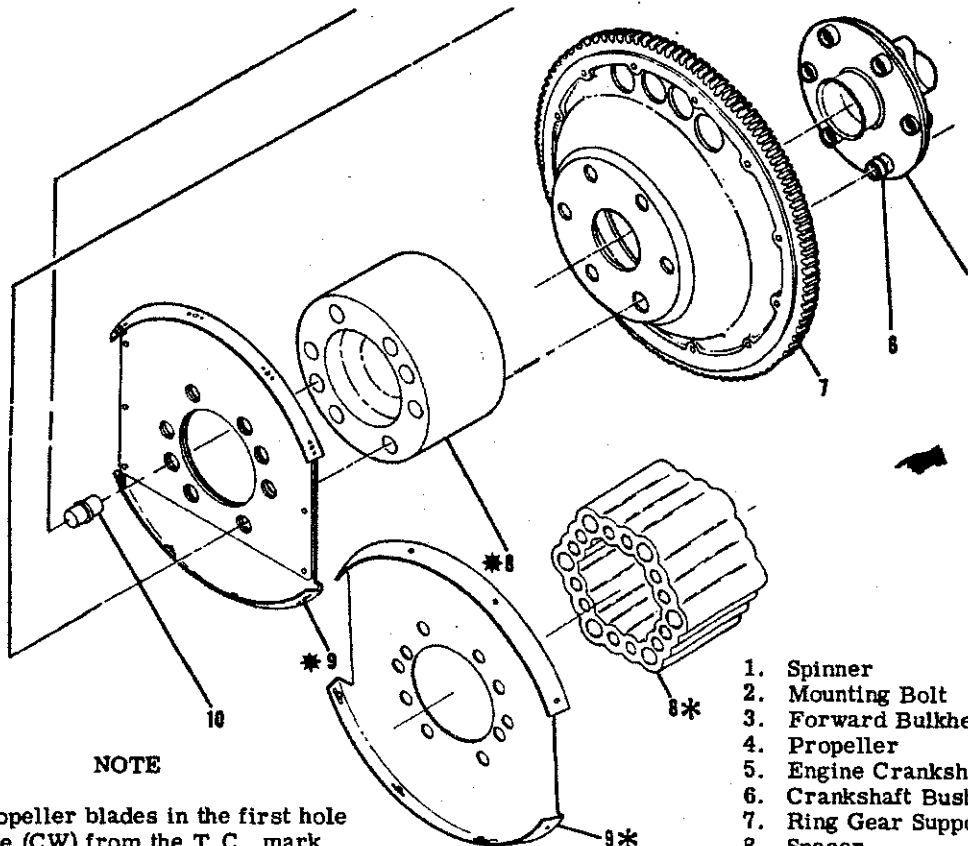

**NOTE**

Index propeller blades in the first hole clockwise (CW) from the T.C. mark located on the aft side of the ring gear as viewed from the front of the engine.

1. Spinner
2. Mounting Bolt
3. Forward Bulkhead
4. Propeller
5. Engine Crankshaft
6. Crankshaft Bushing
7. Ring Gear Support Assembly
8. Spacer
9. Aft Bulkhead
10. Dowel Pin

13-1. Propeller Installation (Lycoming Engines)

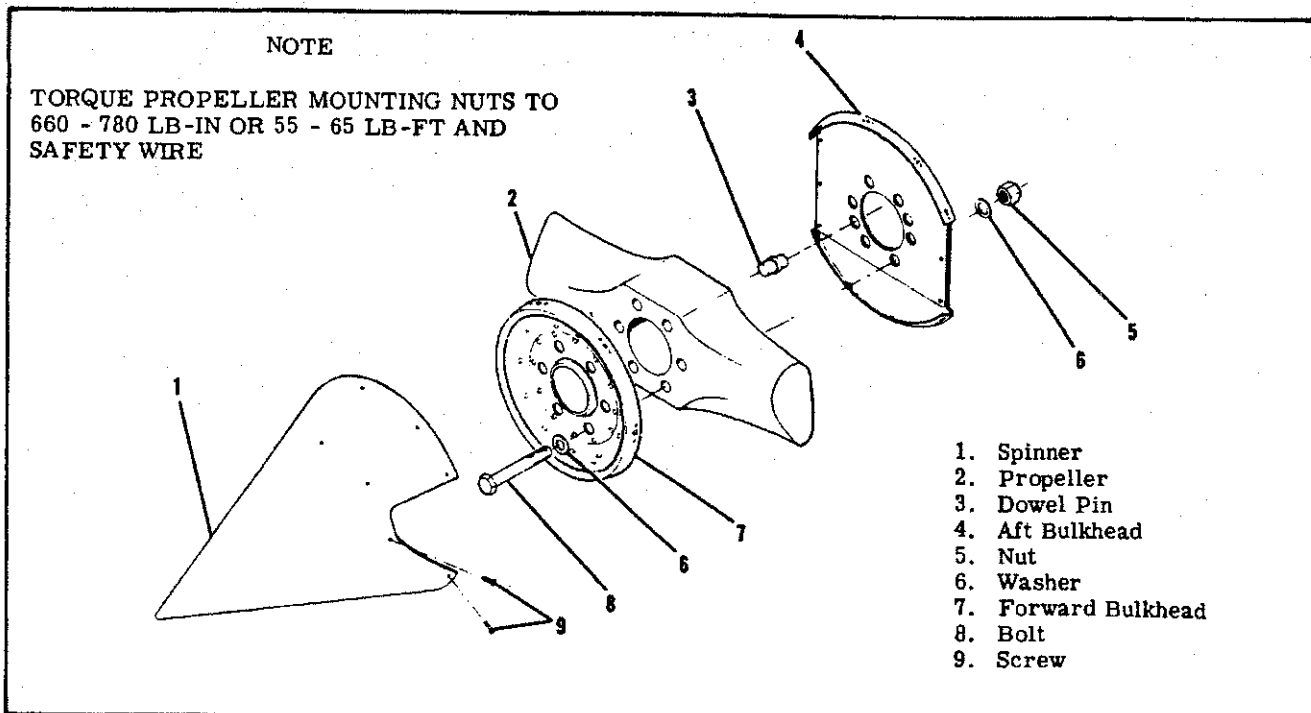

13-2. Propeller Installation (Continental Engines)

c. Clean mating surfaces of the propeller, bulkheads and spacer and assemble as illustrated in figure 13-1.

d. Find the top center (TC) mark on the aft face of the starter ring gear support. Locate one of the propeller blades over the TC mark, rotate the propeller clockwise (as viewed from front of engine) to the first bushing and install propeller.

e. Tighten propeller mounting bolts evenly and torque bolts to 45 lb-ft.

f. Install spinner.

g. Adjust alternator drive belt tension as outlined in Section 16.

13-6. REMOVAL (CONTINENTAL ENGINES).  
(Refer to figure 13-2.)

**WARNING**

Be sure magneto switch is in OFF position before turning propeller.

- a. Remove spinner (1).
- b. Remove propeller mounting nuts, washers and

bolts. Pull propeller forward to remove.

c. The spinner bulkheads (4 and 7) will be freed by removal of the mounting bolts as the propeller is removed.

13-7. INSTALLATION (CONTINENTAL ENGINES)  
(Refer to figure 13-2.)

**WARNING**

Be sure magneto switch is in OFF position before turning propeller.

a. Clean mating surfaces of crankshaft flange, bulkheads and propeller.

b. Position propeller and bulkheads as illustrated in figure 13-2 and install mounting bolts, washers and nuts.

c. Tighten nuts evenly, torque to 55-65 lb-ft and install safety wire.

d. Install spinner. The spinner bulkheads must be positioned so that propeller blades emerge from spinner with ample clearance.





SECTION 14  
UTILITY SYSTEMS

TABLE OF CONTENTS	Page		
UTILITY SYSTEMS . . . . .	14-1	Operation . . . . .	14-4
Heating System . . . . .	14-1	Trouble Shooting . . . . .	14-4
Description . . . . .	14-1	Removal, Installation and Repair . . . . .	14-4
Operation . . . . .	14-1	Ventilating System . . . . .	14-4
Trouble Shooting . . . . .	14-1	Description . . . . .	14-4
Removal, Installation and Repair . . . . .	14-1	Operation . . . . .	14-4
Defroster System . . . . .	14-4	Trouble Shooting . . . . .	14-4
Description . . . . .	14-4	Removal, Installation and Repair . . . . .	14-4

14-1. UTILITY SYSTEMS.

14-2. HEATING SYSTEM.

14-3. DESCRIPTION. The heating system is comprised of the heat exchange section of the exhaust muffler, a shut-off valve, mounted on the right forward side of the firewall a push-pull control on the instrument panel, outlets and flexible ducting connecting the system.

14-4. OPERATION. Ram air is ducted through an engine baffle inlet and heat exchange section of the exhaust muffler, to the shut-off valve at the firewall. The heated air flows from the shut-off valve into a duct across the aft side of the firewall, where it is distributed into the cabin. The shut-off valve, operated by a push-pull control marked "CABIN HEAT," located on the instrument panel, regulates the volume of heated air entering the system. Pulling the control full out supplies maximum flow, and pushing control in gradually decreases flow, shutting off flow completely when the control is pushed full in.

14-5. TROUBLE SHOOTING. Most of the operational troubles in the heating, defrosting and ventilating systems are caused by sticking or binding air valves and/or their controls, damaged air ducting, or defects in the exhaust muffler. In most cases, valves or controls can be freed by proper lubrication.

Damaged or broken parts must be repaired or replaced. When checking controls, ensure valves respond freely to control movement, that they move in the correct direction, and that they move through their range of travel and seal properly. Check that hose are properly secured, and replace hose that are burned, frayed or crushed. If fumes are detected in the cabin, a thorough inspection of the exhaust system should be accomplished. Refer to applicable paragraph in Section 11 for this inspection. Since any holes or cracks may permit exhaust fumes to enter the cabin, replacement of defective parts is imperative because fumes constitute an extreme danger. Seal any gaps in shut-off valves at the firewall with Pro-Seal #700 (Coast Pro-Seal Co., Los Angeles, California) compound, or equivalent compound.

14-6. REMOVAL, INSTALLATION AND REPAIR. Figure 14-1 illustrates the heating and defrosting systems, and may be used as a guide during removal, installation and repair of heating system components. Burned, frayed or crushed hose must be replaced with new hose, cut to length and installed in the original routing. Trim hose winding shorter than the hose to allow clamps to be fitted. Defective air valves must be repaired or replaced. Check for proper operation of valves and their controls after repair or replacement.

## MODEL 172-SERIES

F172-SERIES, BEGINNING WITH 1972 MODELS

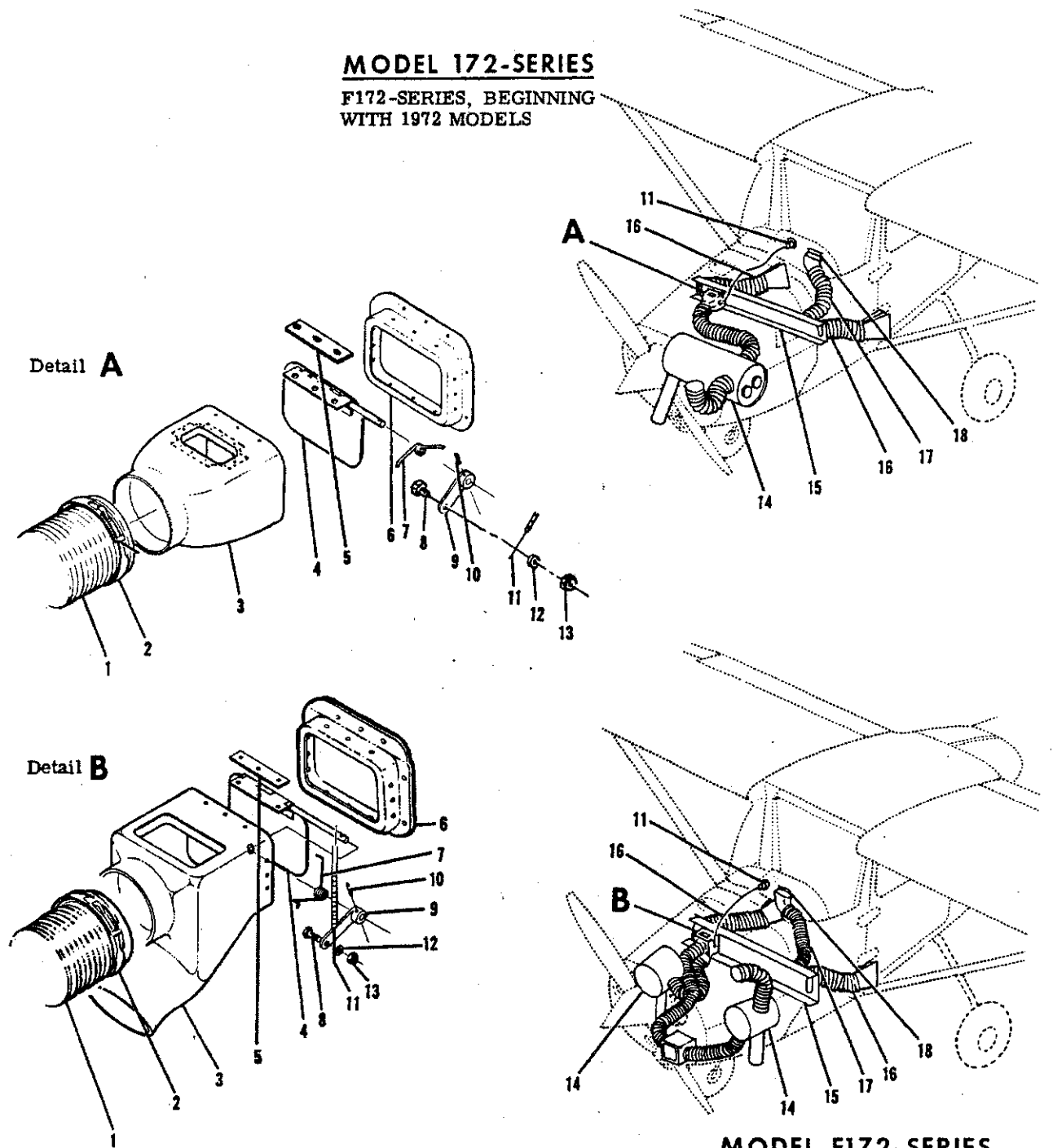

## MODEL F172-SERIES

THRU 1971 MODELS

- |                |                        |                      |
|----------------|------------------------|----------------------|
| 1. Hose        | 7. Spring              | 13. Nut              |
| 2. Clamp       | 8. Clamp Bolt          | 14. Heater Muffler   |
| 3. Valve Body  | 9. Arm                 | 15. Firewall Duct    |
| 4. Valve Plate | 10. Roll Pin           | 16. Duct             |
| 5. Shim        | 11. Cabin Heat Control | 17. Defroster Hose   |
| 6. Valve Seat  | 12. Washer             | 18. Defroster Nozzle |

Figure 14-1. Heating and Defrosting Systems

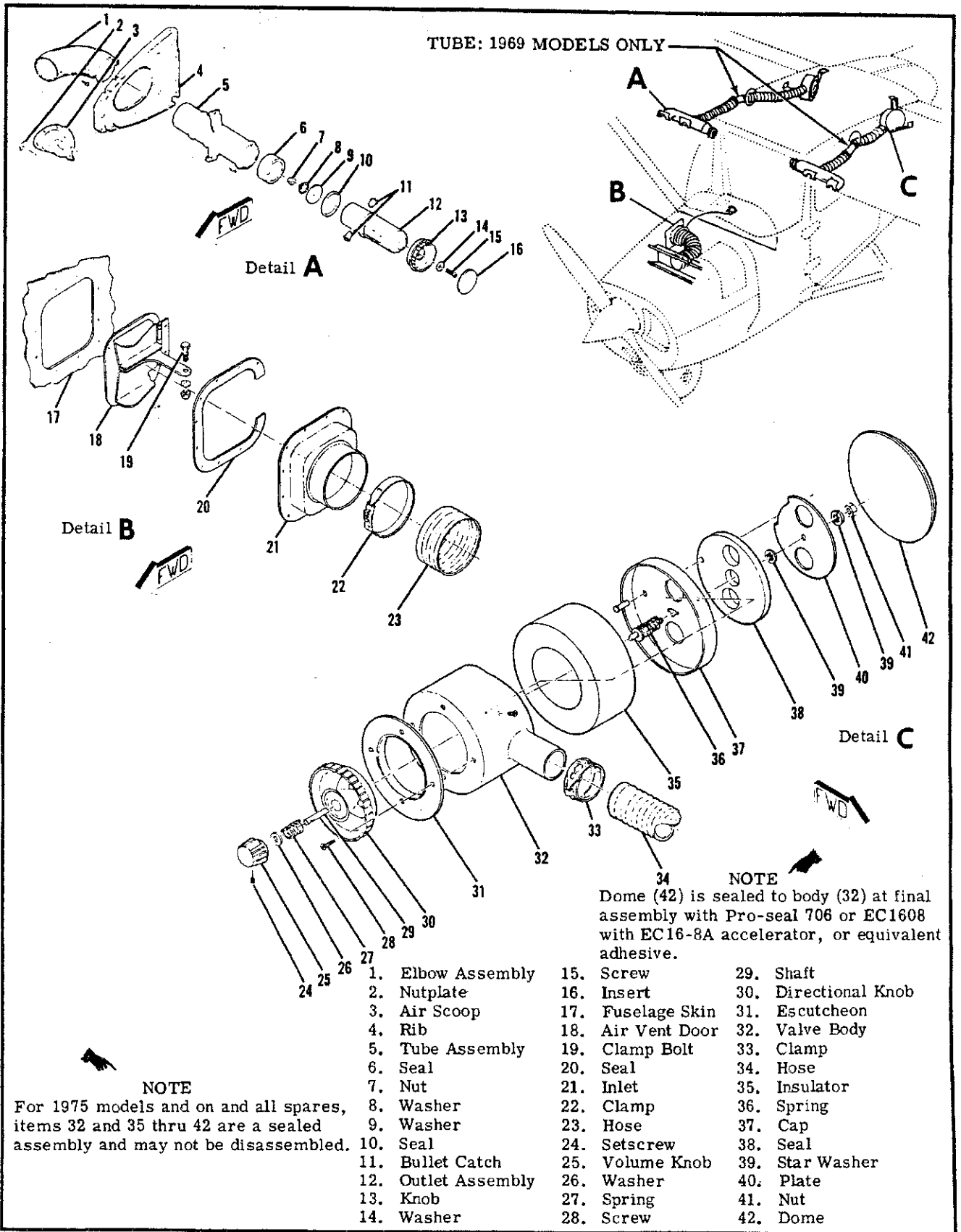

Figure 14-2. Ventilating Systems

14-7. DEFROSTER SYSTEM.

14-8. DESCRIPTION. The defrosting system is comprised of a duct across the aft side of the firewall, defroster outlets, mounted on the left and right sides of the cowl deck immediately aft of the windshield and flexible ducting connecting the system.

14-9. OPERATION. Air from the duct across the aft side of the firewall flows through flexible ducts to the defroster outlets. The temperature and volume of this air is controlled by the settings of the heater system control.

14-10. TROUBLE SHOOTING. Since the defrosting system depends on proper operation of the heating system, refer to paragraph 14-5 for trouble shooting the heating and defrosting systems.

14-11. REMOVAL, INSTALLATION AND REPAIR. Figure 14-1 may be used as a guide for removal, installation and repair of defrosting system components. Cut hose to length and install in the original routing. Trim hose winding shorter than the hose to allow clamps to be fitted. A defective defroster outlet must be repaired or replaced.

14-12. VENTILATING SYSTEM.

14-13. DESCRIPTION. The ventilating system is comprised of two airscoops mounted in the inboard leading edge of each wing, a manually-adjustable ventilator installed on each side of the cabin near the upper corners of the windshield, two plenum chambers mounted in the rear cabin wing root areas, a fresh airscoop door on the right side of the fuselage just forward of the copilot's seat, a control knob on the instrument panel and flexible ducting connecting the system.

14-14. OPERATION. Air received from scoops mounted in the inboard leading edges of the wings is ducted to adjustable ventilators mounted on each side of the cabin near the upper corners of the windshield.

Rear seat ventilation is provided by plenum chambers mounted in the left and right rear cabin wing root areas. These plenum chambers receive ram air from the airscoops in the inboard leading edges of the wings. Each plenum chamber is equipped with a valve which meters the incoming cabin ventilation air. This provides a chamber of expansion of cabin air which greatly reduces inlet air noise. Filters at the air inlets are primarily noise reduction filters. Forward cabin ventilation is provided by a fresh airscoop door mounted on the right side of the fuselage, just forward of the copilot seat. The scoop door is operated by a control in the instrument panel marked "CABIN AIR." Fresh air from the scoop door is routed to the duct across the aft side of the firewall, where it is distributed into the cabin. As long as the "CABIN HEAT" control is pushed in, no heated air can enter the firewall duct; therefore, when the "CABIN AIR" control is pulled out, only fresh air from the scoop will flow through the duct into the cabin. As the "CABIN HEAT" control is gradually pulled out, more and more heated air will blend with the fresh air from the scoop and be distributed into the cabin. Either one, or both of the controls may be set at any position from full open to full closed.

14-15. TROUBLE SHOOTING. Most of the operational troubles in the ventilating system are caused by sticking or binding of the inlet scoop door or its control. Check the airscoop filter elements in the wing leading edges for obstructions. The elements may be removed and cleaned or replaced. Since air passing through the filters is emitted into the cabin, do not use a cleaning solution which would contaminate the air. The filters may be removed to increase air flow. However, their removal will cause a slight increase in noise level.

14-16. REMOVAL, INSTALLATION AND REPAIR. Figure 14-2 may be used as a guide for removal, installation and repair of the ventilating system components. A defective ventilator or scoop must be repaired or replaced. Check for proper operation of ventilating controls after installation or repair.

**SHOP NOTES:**

---

---

---

---

---

---

---

---

---

---

SECTION 15

INSTRUMENTS AND INSTRUMENT SYSTEMS

TABLE OF CONTENTS	Page
INSTRUMENTS AND INSTRUMENT SYSTEMS . . . . .	15-1
General . . . . .	15-1
Instrument Panel . . . . .	15-3
Description . . . . .	15-3
Removal and Installation . . . . .	15-3
Shock-Mounts . . . . .	15-3
Instruments . . . . .	15-3
Removal . . . . .	15-3
Installation . . . . .	15-3
Pitot and Static Systems . . . . .	15-3
Description . . . . .	15-3
Maintenance . . . . .	15-3
Static Pressure System Inspection and Leakage Test . . . . .	15-3
Pitot System Inspection and Leakage Test . . . . .	15-5
Blowing Out Lines . . . . .	15-5
Removal and Installation of Components . . . . .	15-5
Trouble Shooting - Pitot Static System . . . . .	15-6
True Airspeed Indicator . . . . .	15-6
Trouble Shooting . . . . .	15-6
Trouble Shooting - Altimeter . . . . .	15-8
Trouble Shooting - Vertical Speed Indicator . . . . .	15-8
Trouble Shooting - Pitot Tube Heater . . . . .	15-9
Pitot Tube Alignment . . . . .	15-9
Vacuum System . . . . .	15-9
Description . . . . .	15-9
Trouble Shooting . . . . .	15-11
Trouble Shooting - Gyros . . . . .	15-11
Trouble Shooting - Vacuum Pump . . . . .	15-15
Removal and Installation of Components . . . . .	15-15
Cleaning . . . . .	15-15
Vacuum Relief Valve Adjustment . . . . .	15-15
Engine Indicators . . . . .	15-16
Tachometer . . . . .	15-16
Description . . . . .	15-16
Oil Pressure Gage . . . . .	15-16
Description . . . . .	15-16
Trouble Shooting . . . . .	15-16
Oil Temperature gage . . . . .	15-17
Description . . . . .	15-17
Carburetor Air Temperature Gage . . . . .	15-17
Description . . . . .	15-17
Trouble Shooting . . . . .	15-17
Fuel Quantity Indicating System . . . . .	15-18
Description . . . . .	15-18
Removal and Installation . . . . .	15-18
Trouble Shooting . . . . .	15-19
Transmitter Calibration . . . . .	15-19
Hourmeter . . . . .	15-19
Description . . . . .	15-19
Magnetic Compass . . . . .	15-20
Description . . . . .	15-20
Stall Warning System . . . . .	15-20
Description . . . . .	15-20
Turn Coordinator . . . . .	15-21
Description . . . . .	15-21
Trouble Shooting . . . . .	15-21
Turn-and-Slip Indicator . . . . .	15-22
Description . . . . .	15-22
Trouble Shooting . . . . .	15-22
Wing Leveler . . . . .	15-25
Description . . . . .	15-25
Rigging . . . . .	15-25

15-1. INSTRUMENTS AND INSTRUMENT SYSTEMS.

15-2. GENERAL. This section describes typical instrument installations and their respective operating systems. Emphasis is placed on trouble shooting and corrective measures only. It does NOT deal with specific instrument repairs since this usually requires special equipment and data and should be handled by instrument specialists. Federal Aviation Regulations require malfunctioning instruments be sent to an approved instrument overhaul and repair station or returned to manufacturer for servicing. Our concern here is with preventive maintenance on various instrument systems and correction of system faults which result in instrument malfunctions. The descriptive material, maintenance and trouble shooting

information in this section is intended to help the mechanic determine malfunctions and correct them, up to the defective instrument itself, at which point an instrument technician should be called in. Some instruments, such as fuel quantity and oil pressure gages, are so simple and inexpensive, repairs usually will be more costly than a new instrument. On the other hand, aneroid and gyro instruments usually are well worth repairing. The words "replace instrument" in the text, therefore, should be taken only in the sense of physical replacement in aircraft. Whether replacement is to be with a new instrument, an exchange one, or original instrument is to be repaired must be decided on basis of individual circumstances.

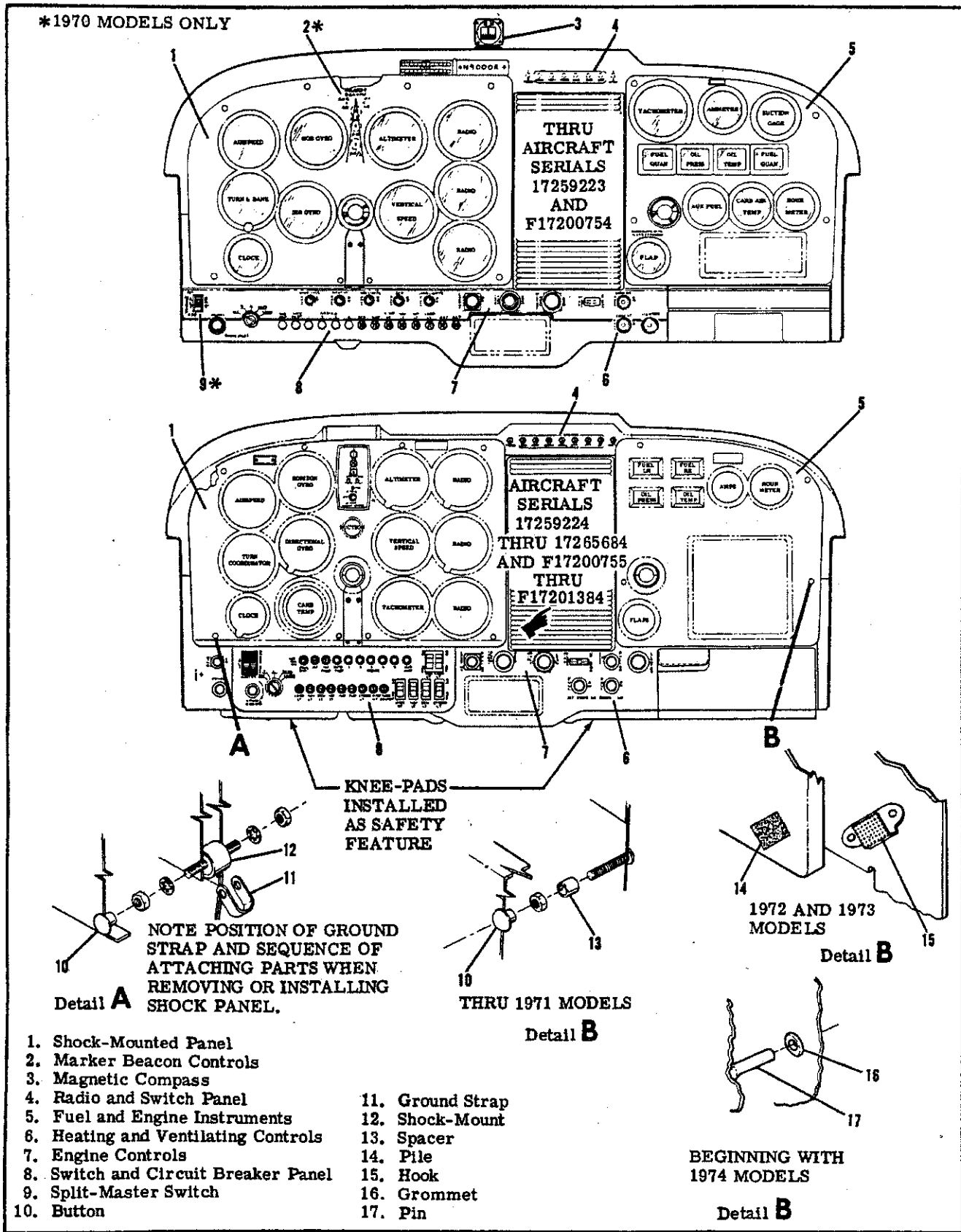

Figure 15-1. Typical Instrument Panel (Sheet 1 of 2)

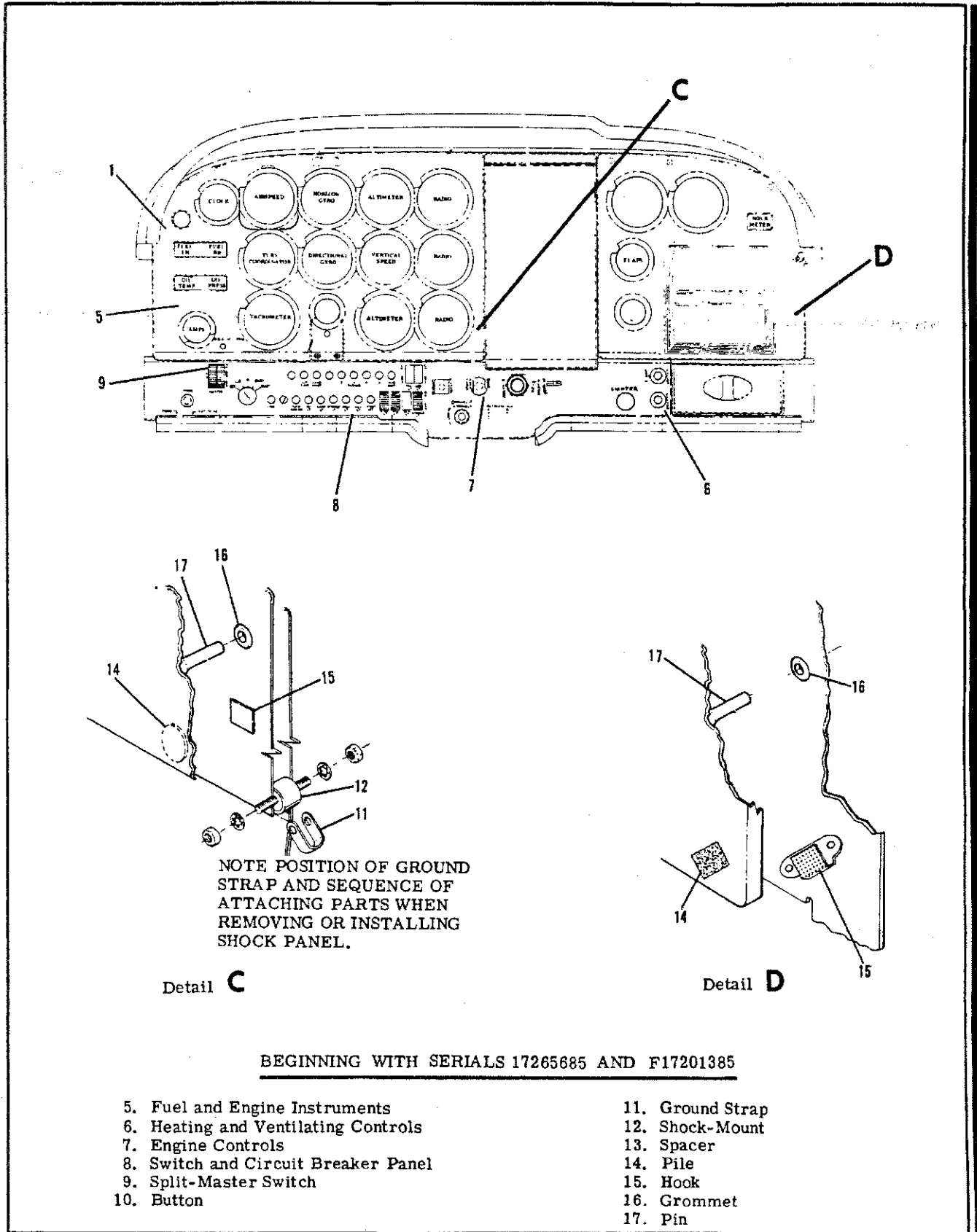

Figure 15-1. Typical Instrument Panel (Sheet 2 of 2)





15-3. INSTRUMENT PANEL. (Refer to figure 15-1.)

15-4. DESCRIPTION. The instrument panel assembly consists of a stationary and shock-mounted panel. The stationary panel contains instruments which are NOT sensitive to vibration. The shock-mounted panel contains major flight instruments such as horizontal and directional gyros which are affected by vibration. Most of the instruments are screw-mounted on the panel backs.

15-5. REMOVAL AND INSTALLATION. The stationary panel is secured to engine mount stringers and a forward fuselage bulkhead and ordinarily is not considered removable. The shock-mounted panel is secured to stationary panel with rubber shock-mounted assemblies. To remove shock-mounted panel proceed as follows:

- a. Remove left control wheel and tube assembly by removing bolt at universal joint. (1969 Models only.)
- b. Thru 1971 Models unscrew threaded buttons securing decorative covers, 1972 and 1973 Models Velcro Fasteners are used. Beginning with 1974 Models a pin and grommet arrangement is used.
- c. Remove nuts from shock-mounts, tag and disconnect instrument wiring and plumbing and pull panel straight back.
- d. Reverse preceding steps for installation. Ensure ground strap is properly installed.

15-6. SHOCK MOUNTS. Service life of instruments is directly related to adequate shock-mounting of panel. If removal of panel is necessary, check mounts for deterioration.

15-7. INSTRUMENTS. (Refer to figure 15-1.)

15-8. REMOVAL. Most instruments are secured to panel with screws inserted through panel face. To remove an instrument, remove decorative cover, disconnect wiring or plumbing to instrument, remove mounting screws and take instrument out from behind, or in some cases, from front of panel. Instrument clusters are installed as units and are secured by a screw at each end. A cluster must be removed from panel to replace an individual gage.

NOTE

Thru 1975 models, the clusters are located directly above the glove box. Removal of cluster will be simpler if glove box is removed first.

In all cases when an instrument is removed, disconnected lines or wires should be protected. Cap open lines and cover pressure connections on instrument to prevent thread damage and entrance of foreign matter. Wire terminals should be insulated or tied up to prevent accidental grounding or short-circuiting.

15-9. INSTALLATION. Generally, installation procedure is the reverse of removal procedure. Ensure mounting screw nuts are tightened firmly, but do not over-tighten, particularly on instruments having plastic cases. The same rule applies to connecting plumbing and wiring.

NOTE

All instruments (gages and indicators), requiring a thread seal or lubricant, shall be installed using teflon tape on male fittings only. This tape is available through Cessna Service Parts Center.

When replacing an electrical gage in an instrument cluster assembly, avoid bending pointer or dial plate. Distortion of dial or back plate could change calibration of gages.

15-10. PITOT AND STATIC SYSTEMS. (Refer to figure 15-2.)

15-11. DESCRIPTION. The pitot system conveys ram air pressure to the airspeed indicator. The static system vents vertical speed indicator, altimeter and airspeed indicator to atmospheric pressure through plastic tubing connected to a static port. A static line sump is installed at source button to collect condensation in static system. A pitot tube heater may be installed. The heating element is controlled by a switch at instrument panel and powered by the electrical system. An alternate static source valve may be installed in the static system for use when the external static source is malfunctioning. Refer to the Owner's Manual for flight operation using the alternate static source. Beginning with serial 17263459, an encoding altimeter may be installed which is also connected to static system pressure. The encoding altimeter supplies coded altitude signals to the aircraft's transponder for transmission to ground based interrogating radar. The encoding altimeter installation requires the use of a fully operational secondary altimeter as backup. Figure 15-2, sheet 2 may be used as a guide for removal and installation of the encoding altimeter.

15-12. MAINTENANCE. Proper maintenance of pitot and static system is essential for proper operation of altimeter, vertical speed and airspeed indicators. Leaks, moisture and obstructions in pitot system will result in false airspeed indications, while static system malfunctions will affect readings of all three instruments. Under instrument flight conditions, these instrument errors could be hazardous. Cleanliness and security are the principal rules for system maintenance. The pitot tube and static ports MUST be kept clean and unobstructed.

15-13. STATIC PRESSURE SYSTEM INSPECTION AND LEAKAGE TEST. The following procedure outlines inspection and testing of static pressure system, assuming altimeter has been tested and inspected in accordance with current Federal Aviation Regulations.

- a. Ensure static system is free from entrapped moisture and restrictions.
- b. Ensure no alterations or deformations of airframe surface have been made which would affect the relationship between air pressure in static pressure system and true ambient static air pressure for any flight configuration.
- c. Close static pressure alternate source control, if installed.

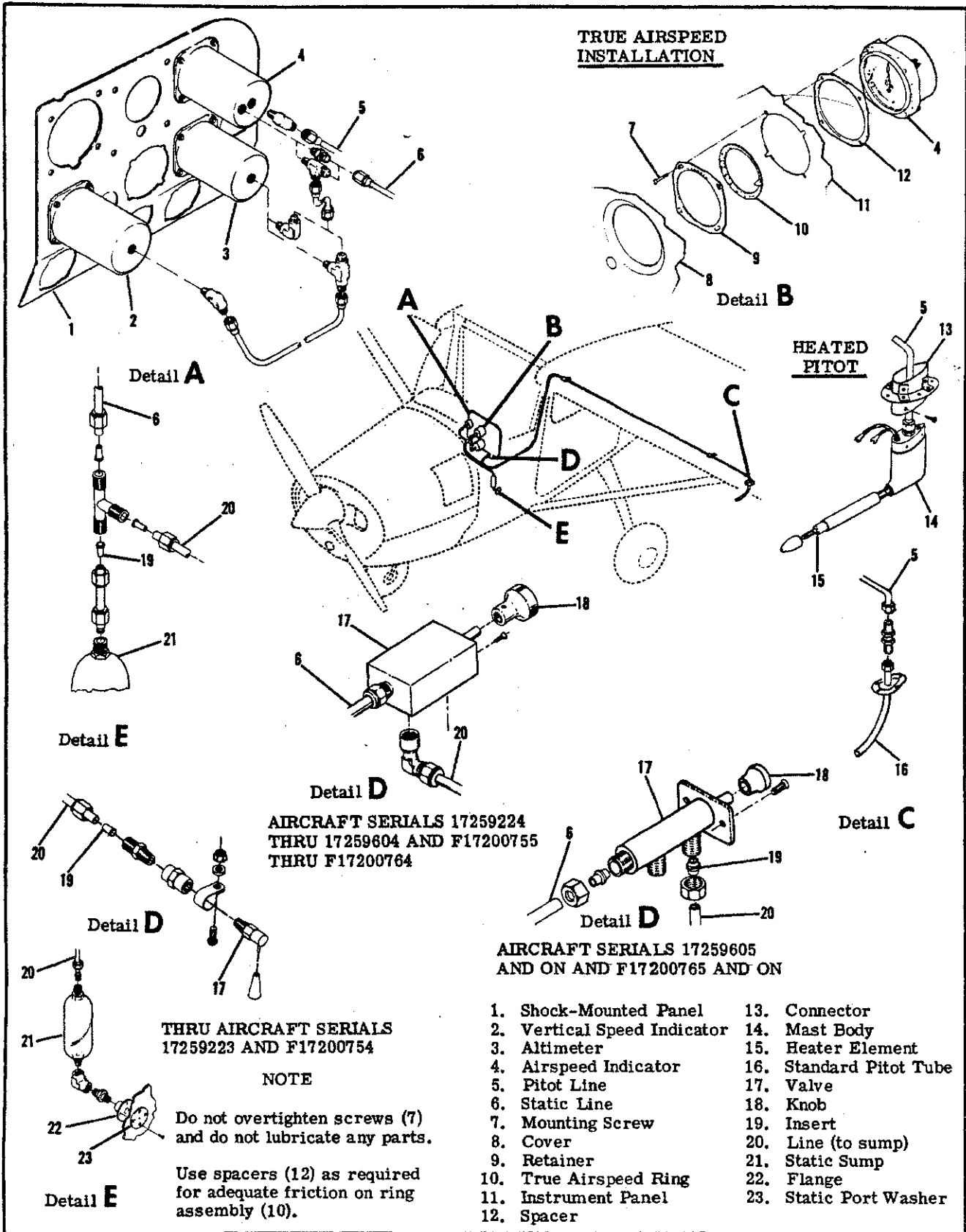
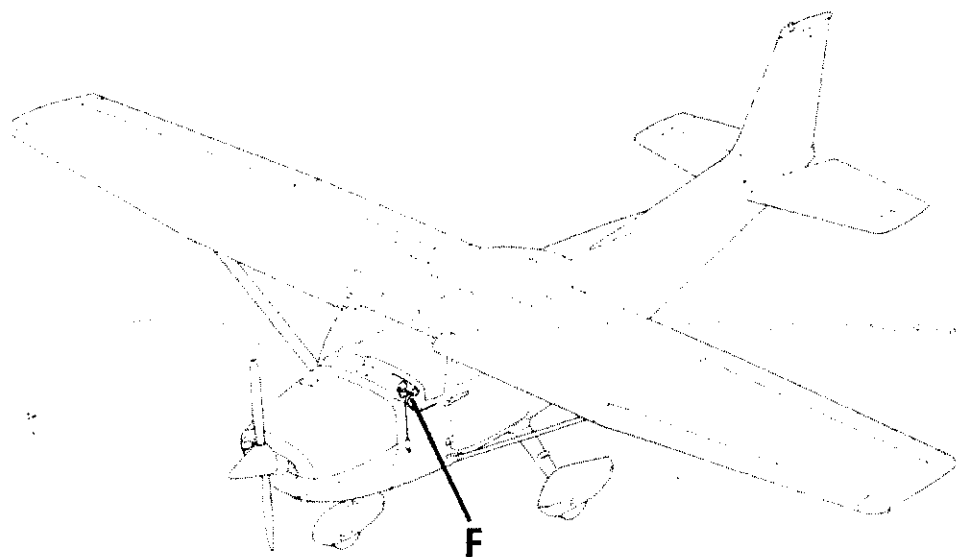
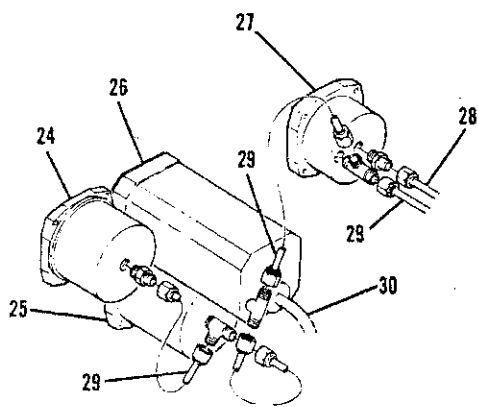

Figure 15-2. Pitot-Static Systems (Sheet 1 of 2)



ENCODING ALTIMETER INSTALLATION



Detail **F**

SERIALS 17263459 THRU 17265684

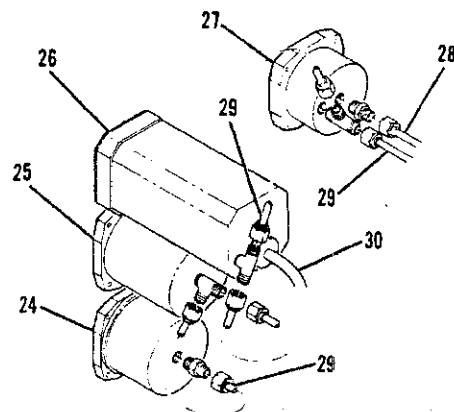

Detail **F**

BEGINNING WITH SERIALS 17265685

- 24. Backup Altimeter
- 25. Vertical Speed Indicator
- 26. Encoding Altimeter
- 27. Airspeed Indicator
- 28. Pitot Line
- 29. Static Line
- 30. Cable (To Transponder)

Figure 15-2. Pitot-Static Systems (Sheet 2 of 2)



- d. Attach a source of suction to static pressure source opening. Figure 15-3 shows one method of obtaining suction.
- e. Slowly apply suction until altimeter indicates a 1000-foot increase in altitude.

**CAUTION**

When applying or releasing suction, do not exceed range of vertical speed indicator or airspeed indicator.

- f. Cut off suction source to maintain a "closed" system for one minute. Leakage shall not exceed 100 feet of altitude loss as indicated on altimeter.
- g. If leakage rate is within tolerance, slowly release suction source.

**NOTE**

If leakage rate exceeds maximum allowable, first tighten all connections, then repeat leakage test. If leakage rate still exceeds maximum allowable, use following procedure.

- h. Disconnect static pressure lines from airspeed indicator and vertical speed indicator. Use suitable fittings to connect lines together so altimeter is the only instrument still connected into static pressure system.
- i. Repeat leakage test to check whether static pressure system or the bypassed instruments are cause of leakage. If instruments are at fault, they must be repaired by an "appropriately rated repair station" or replaced. If static pressure system is at fault, use following procedure to locate leakage.
- j. Attach a source of positive pressure to static source opening. Figure 15-3 shows one method of obtaining positive pressure.

**CAUTION**

Do not apply positive pressure with airspeed indicator or vertical speed indicator connected to static pressure system.

- k. Slowly apply positive pressure until altimeter indicates a 500-foot decrease in altitude and maintain this altimeter indication while checking for leaks. Coat line connections and static source flange with solution of mild soap and water, watching for bubbles to locate leaks.
- l. Tighten leaking connections. Repair or replace parts found defective.
- m. Reconnect airspeed and vertical speed indicators into static pressure system and repeat leakage test per steps "c" thru "g".

15-14. PITOT SYSTEM INSPECTION AND LEAKAGE TEST. To check pitot system for leaks, place a piece of tape over small hole in lower aft end of pitot tube, fasten a piece of rubber or plastic tubing over pitot tube, close opposite end of tubing and slowly roll up tube until airspeed indicator registers in cruise range.

Secure tube and after a few minutes recheck airspeed indicator. Any leakage will have reduced the pressure in system, resulting in a lower airspeed indication. Slowly unroll tubing before removing it, so pressure is reduced gradually. Otherwise instrument may be damaged. If test reveals a leak in system, check all connections for tightness.

15-15. BLOWING OUT LINES. Although pitot system is designed to drain down to pitot tube opening, condensation may collect at other points in system and produce a partial obstruction. To clear line, disconnect at airspeed indicator. Using low pressure air, blow from indicator end of line toward pitot tube.

**CAUTION**

Never blow through pitot or static lines toward instruments.

Like pitot lines, static pressure lines must be kept clear and connections tight. All models have a static source sump which collects moisture and keeps system clear. However, when necessary, disconnect static line at first instrument to which it is connected, then blow line clear with low-pressure air. Check all static pressure line connections for tightness. If hose or hose connections are used, check for general condition and clamps for security. Replace hose which have cracked, hardened or show other signs of deterioration.

15-16. REMOVAL AND INSTALLATION OF COMPONENTS. (Refer to figure 15-2.) To remove pitot mast remove four mounting screws on side of connector (13) and pull mast out of connector far enough to disconnect pitot line (5). Electrical connections to heater assembly (if installed) may be disconnected through wing access opening just in-board of mast. Pitot and static lines are removed in the usual manner, after removing wing access plates, lower wing fairing strip and upholstery as required. Installation of tubing will be simpler if a guide wire is drawn in as tubing is removed from wing. The tubing may be removed intact by drawing it out through cabin and right door. Tighten connections firmly but avoid overtightening and distorting fittings. If twisting of plastic tubing is encountered when tightening fittings, VV-P-236 (USP-Petrolatum), may be applied sparingly between tubing and fittings.

15-17. TROUBLE SHOOTING--PITOT STATIC SYSTEM.

TROUBLE	PROBABLE CAUSE	REMEDY
LOW OR SLUGGISH AIRSPEED INDICATION. (Normal altimeter and vertical speed.)	Pitot tube obstructed, leak or obstruction in pitot line.	Test pitot tube and line for leaks or obstructions. Blow out tube and line, repair or replace damaged line.
INCORRECT OR SLUGGISH RESPONSE. (all three instruments.)	Leaks or obstruction in static line.	Test line for leaks and obstructions. Repair or replace line, blow out obstructed line.

15-18. TRUE AIRSPEED INDICATOR. A true airspeed indicator may be installed. This indicator, equipped with a conversion ring, may be rotated until pressure altitude is aligned with outside air temperature, then airspeed indicated on the instrument is read as true airspeed on the adjustable ring. Refer to figure 15-2 for removal and installation. Upon installation, before tightening mounting screws (7), calibrate instrument as follows: Rotate ring (10) until 120 mph on the adjustable ring aligns with 120 mph on the in-

dicator. Holding this setting, move retainer (9) until 60°F aligns with zero pressure altitude, then tighten mounting screws (7) and replace decorative cover (8).

NOTE

Beginning with 1976 models, true airspeed indicators are graduated in knots. Therefore, use 105 knots in the above calibration procedure instead of 120 miles per hour.

15-19. TROUBLE SHOOTING--AIRSPEED INDICATOR.

TROUBLE	PROBABLE CAUSE	REMEDY
HAND FAILS TO RESPOND.	Pitot pressure connection not properly connected to pressure line from pitot tube.	Test line and connection for leaks. Repair or replace damaged line, tighten connections.
	Pitot or static lines clogged.	Check line for obstructions. Blow out lines.
INCORRECT INDICATION OR HAND OSCILLATES.	Leak in pitot or static lines.	Test lines and connections for leaks. Repair or replace damaged lines, tighten connections.
	Defective mechanism or leaking diaphragm.	Substitute known-good indicator and check reading. Replace instrument.
HAND VIBRATES.	Excessive vibration.	Check panel shock mounts. Replace defective shock mounts.
	Excessive tubing vibration.	Check clamps and line connections for security. Tighten clamps and connections, replace tubing with flexible hose.

NOTE

Air bulb with check valves may be obtained locally from a surgical supply company. This is the type used in measuring blood pressure.

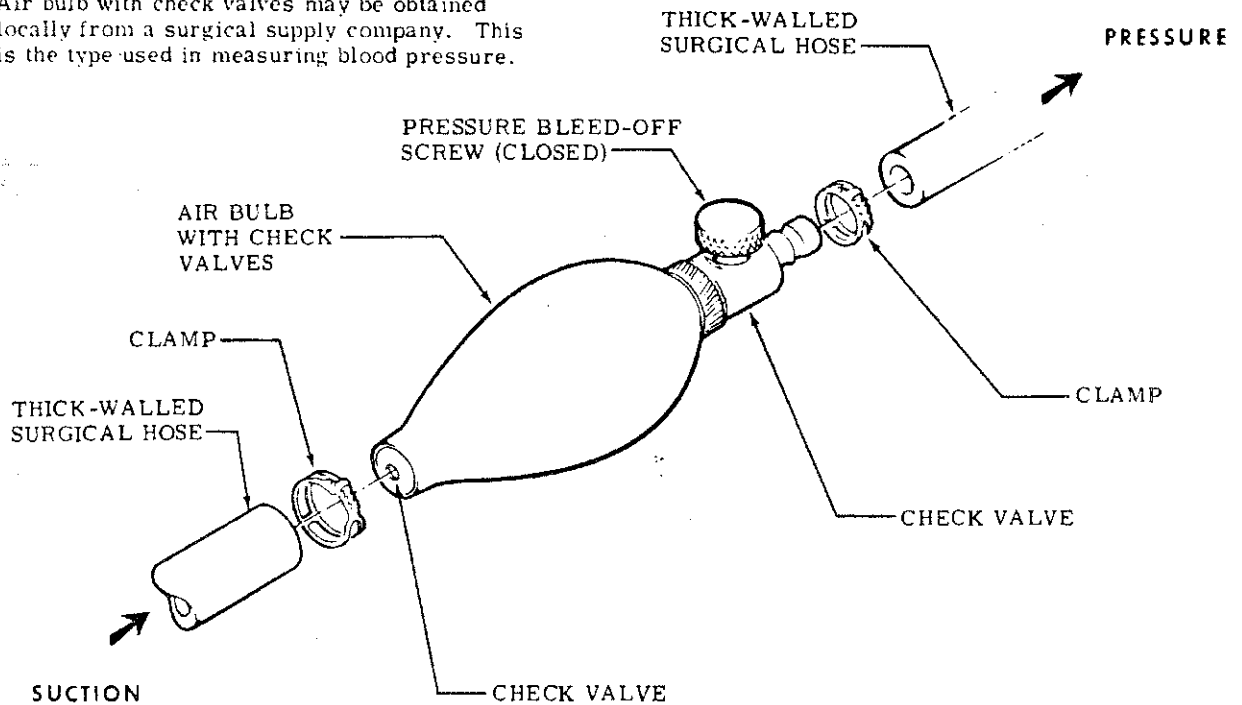

TO APPLY SUCTION:

1. Squeeze air bulb to expel as much air as possible.
2. Hold suction hose firmly against static pressure source opening.
3. Slowly release air bulb to obtain desired suction, then pinch hose shut tightly to trap suction in system.
4. After leak test, release suction slowly by intermittently allowing a small amount of air to enter static system. To do this, tilt end of suction hose away from opening, then immediately tilt it back against opening. Wait until vertical speed indicator approaches zero, then repeat. Continue to admit this small amount of air intermittently until all suction is released, then remove test equipment.

TO APPLY PRESSURE:

**CAUTION**

Do not apply positive pressure with airspeed indicator or vertical speed indicator connected into static system.

1. Hold pressure hose firmly against static pressure source opening.
2. Slowly squeeze air bulb to apply desired pressure to static system. Desired pressure may be maintained by repeatedly squeezing bulb to replace any air escaping through leaks.
3. Release pressure by slowly opening pressure bleed-off screw, then remove test equipment.

Figure 15-3. Static Test Equipment

15-20. TROUBLE SHOOTING--ALTIMETER

TROUBLE	PROBABLE CAUSE	REMEDY
INSTRUMENT FAILS TO OPERATE.	Static line plugged.	Check line for obstructions. Blow out lines.
	Defective mechanism.	Substitute known-good altimeter and check reading. Replace instrument.
INCORRECT INDICATION.	Hands not carefully set.	Reset hands with knob.
	Leaking diaphragm.	Substitute known-good altimeter and check reading. Replace instrument.
	Pointers out of calibration.	Compare reading with known-good altimeter. Replace instrument.
HAND OSCILLATES.	Static pressure irregular.	Check lines for obstruction or leaks. Blow out lines, tighten connections.
	Leak in airspeed or vertical speed indicator installations.	Check other instruments and system plumbing for leaks. Blow out lines, tighten connections.

15-21. TROUBLE SHOOTING--VERTICAL SPEED INDICATOR.

TROUBLE	PROBABLE CAUSE	REMEDY
INSTRUMENT FAILS TO OPERATE.	Static line plugged.	Check line for obstructions. Blow out lines.
	Static line broken.	Check line for damage, connections for security. Repair or replace damaged line, tighten connections.
INCORRECT INDICATION.	Partially plugged static line.	Check line for obstructions. Blow out lines.
	Ruptured diaphragm.	Substitute known-good indicator and check reading. Replace instrument.
	Pointer off zero.	Reset pointer to zero. Reset pointer to zero.
POINTER OSCILLATES.	Partially plugged static line.	Check line for obstructions. Blow out lines.



15-21. TROUBLE SHOOTING--VERTICAL SPEED INDICATOR. (Cont)

TROUBLE	PROBABLE CAUSE	REMEDY
POINTER OSCILLATES. (cont).	Leak in static line.	Test lines and connections for leaks. Repair or replace damaged lines, tighten connections.
	Leak in instrument case.	Substitute known-good indicator and check reading. Replace instrument.
HAND VIBRATES.	Excessive vibration.	Check shock mounts. Replace defective shock mounts.
	Defective diaphragm.	Substitute known-good indicator and check for vibration. Replace instrument.

15-22. TROUBLE SHOOTING--PITOT TUBE HEATER.

TROUBLE	PROBABLE CAUSE	REMEDY
TUBE DOES NOT HEAT OR CLEAR ICE.	Switch turned "OFF."	Turn switch "ON."
	Popped circuit breaker.	Check visually. Reset breaker.
	Break in wiring.	Test for open circuit. Repair wiring.
	Heating element burned out.	Check resistance of heating element. Replace element.

15-23. PITOT TUBE ALIGNMENT. (Refer to figure 15-2.) For correct airspeed indication pitot tube (18) must be properly aligned. Open end of tube must be perpendicular to longitudinal axis of aircraft. A template like the one shown in figure 15-4 will prove the most convenient means of checking alignment. Prior to using template, check that pitot tube parallels row of rivets just outboard of tube. A straightedge may be placed along row of rivets to check the alignment. The template fits over the wing leading edge and should conform to the illustration. The illustration has been drawn carefully to actual size and may be traced directly on a piece of carbon paper between the printed page and the template material, the contours can be traced.

15-24. VACUUM SYSTEM. (Refer to figure 15-5.)

15-25. DESCRIPTION. Suction to operate the gyros is provided by an engine-driven vacuum pump, gear-driven through a spline-type coupling. The Model F172, through aircraft serial F17200805, utilized a wet system in which the air discharges into an oil separator after lubricating the pump, then is expelled overboard. The Model 172 and the F172 beginning with aircraft serial F17200805, utilizes a dry-type pump which requires no oil separator. A suction relief valve, to control system pressure, is connected between the pump inlet and the instruments. In the cabin, the vacuum line is routed from gyro instruments to the relief valve at the firewall. A central air filtering system is utilized. Beginning with aircraft 17262867 and F17201240 a disposable type air filter is utilized. The reading of the suction gage indicates net difference in suction before and after air passes through a gyro. This differential pressure will gradually decrease as the central air filter becomes dirty, causing a lower reading on the suction gage.

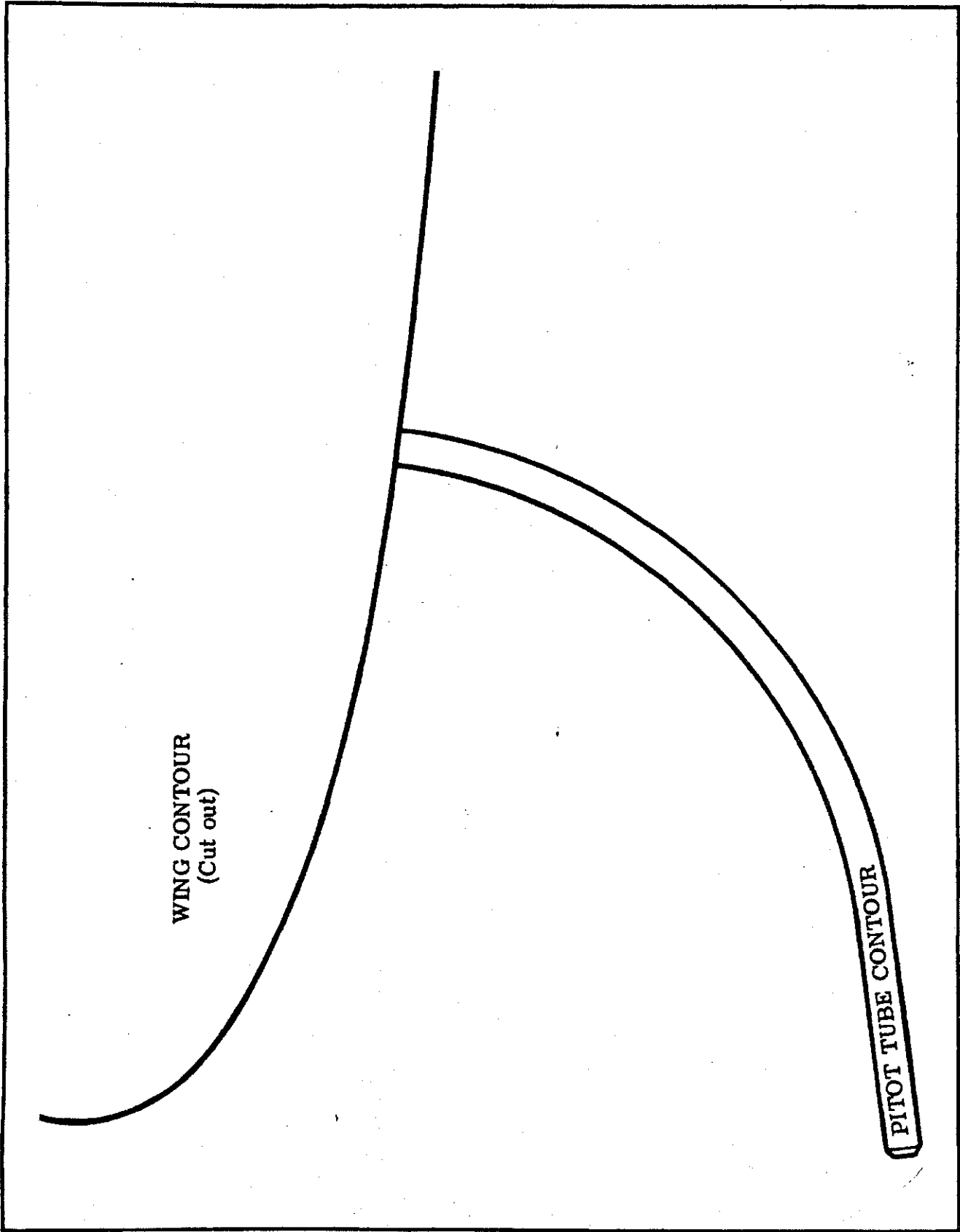

Figure 15-4. Pitot Tube Alignment Template

15-26. TROUBLE SHOOTING--VACUUM SYSTEM

TROUBLE	PROBABLE CAUSE	REMEDY
HIGH SUCTION GAGE READINGS.	Gyros function normally-relief valve screen clogged, relief valve malfunction.	Check screen, than valve. Compare gage readings with new gage. Clean screen, reset valve. Replace gage.
NORMAL SUCTION GAGE READING, SLUGGISH OR ERRATIC GYRO RESPONSE.	Instrument air filters clogged.	Check operation with filters removed. Replace filters.
LOW SUCTION GAGE READINGS.	Leaks or restriction between instruments and relief valve, relief valve out of adjustment, defective pump.	Check lines for leaks, disconnect and test pump. Repair or replace lines, adjust or replace relief valve, repair or replace pump.
	Central air filter dirty.	Check operation with filter removed. Clean or replace filter.
SUCTION GAGE FLUCTUATES.	Defective gage or sticking relief valve.	Check suction with test gage. Replace gage. Clean sticking valve with Stoddard solvent. Blow dry and test. If valve sticks after cleaning, replace valve.

15-27. TROUBLE SHOOTING--GYROS.

TROUBLE	PROBABLE CAUSE	REMEDY
HORIZON BAR FAILS TO RESPOND.	Central filter dirty.	Check filter. Clean or replace filter.
	Suction relief valve improperly adjusted.	Adjust or replace relief valve.
	Faulty suction gage.	Substitute known-good suction gage and check gyro response. Replace suction gage.
	Vacuum pump failure.	Check pump. Replace pump.
	Vacuum line kinked or leaking.	Check lines for damage and leaks. Repair or replace damaged lines. Tighten connections.
HORIZON BAR DOES NOT SETTLE.	Defective mechanism.	Substitute known-good gyro and check indication. Replace instrument.
	Insufficient vacuum.	Adjust or replace relief valve.
	Excessive vibration.	Check panel shock-mounts. Replace defective shock-mounts.

15-27. TROUBLE SHOOTING--GYROS. (Cont).

TROUBLE	PROBABLE CAUSE	REMEDY
HORIZON BAR OSCILLATES OR VIBRATES EXCESSIVELY.	Central filter dirty.	Check filter. Clean or replace filter.
	Suction relief valve improperly adjusted.	Adjust or replace relief valve.
	Faulty suction gage.	Substitute known-good suction gage and check gyro indication. Replace suction gage.
	Defective mechanism.	Substitute known-good gyro and check indication. Replace instrument.
	Excessive vibration.	Check panel shock-mounts. Replace defective shock-mounts.
EXCESSIVE DRIFT IN EITHER DIRECTION.	Central air filter dirty.	Check filter. Clean or replace filter.
	Low vacuum, relief valve improperly adjusted.	Adjust or replace relief valve.
	Faulty suction gage.	Substitute known-good suction gage and check gyro indication. Replace suction gage.
	Vacuum pump failure.	Check pump. Replace pump.
	Vacuum line kinked or leaking.	Check lines for damage and leaks. Repair or replace damaged lines, tighten connections.
DIAL SPINS IN ONE DIRECTION CONTINUOUSLY.	Operating limits have been exceeded.	Replace instrument.
	Defective mechanism.	Substitute known-good gyro and check indication. Replace instrument.

**SHOP NOTES:**

---



---



---



---



---

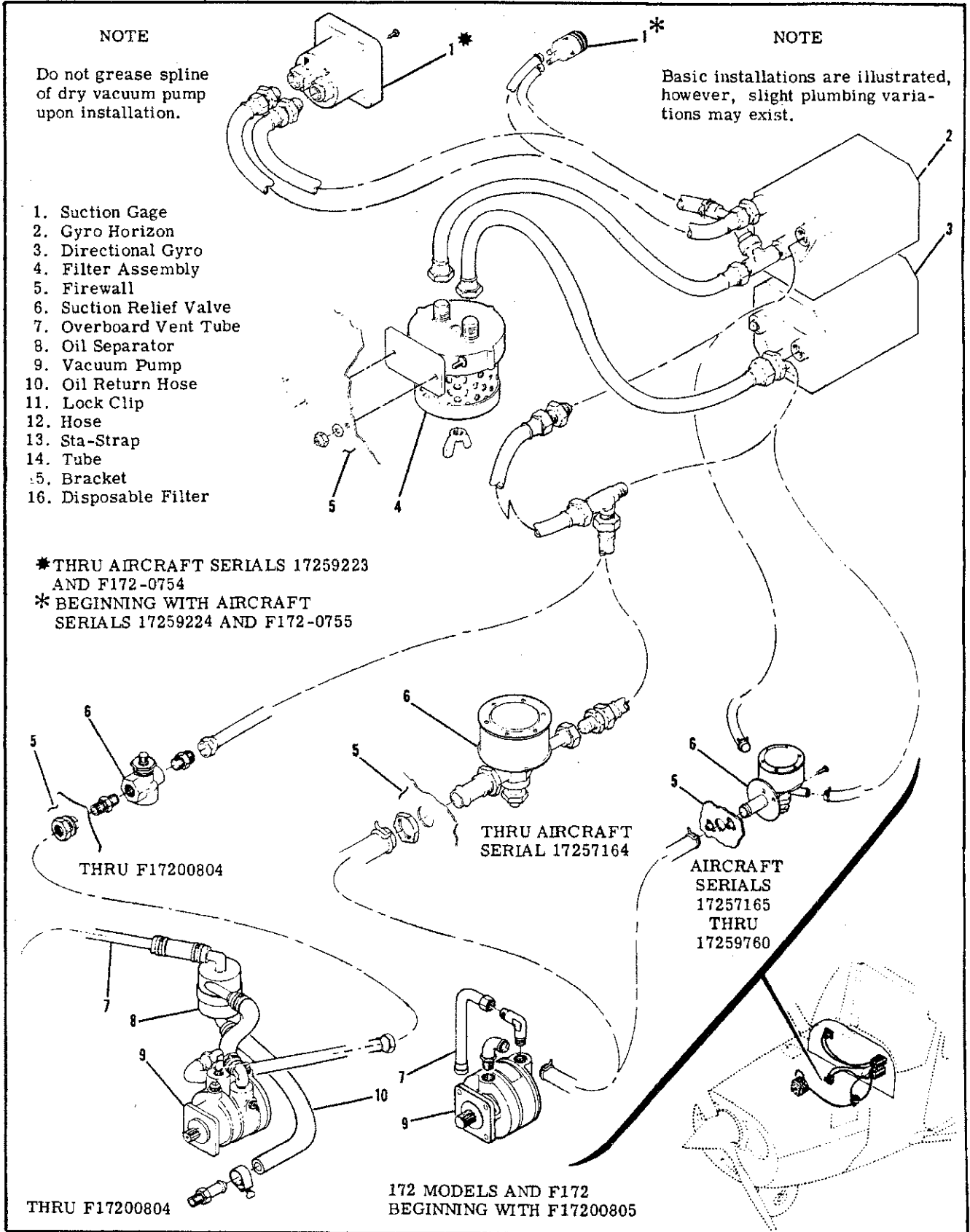
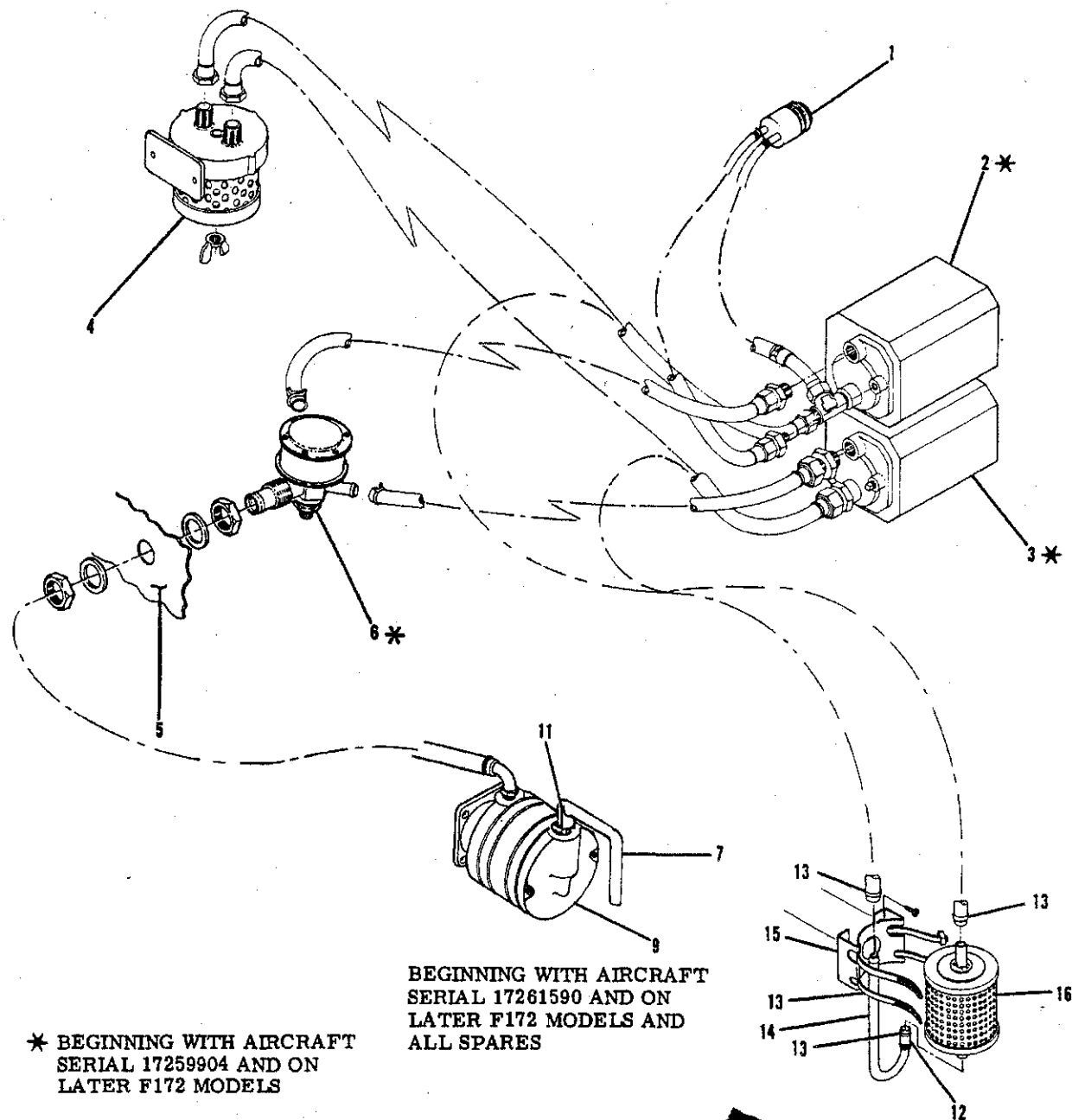

Figure 15-5. Vacuum System (Sheet 1 of 2)

THRU SERIALS 17262866 AND F17201239



\* BEGINNING WITH AIRCRAFT SERIAL 17259904 AND ON LATER F172 MODELS

\* BEGINNING WITH AIRCRAFT SERIALS 17259761 AND F17200805

BEGINNING WITH AIRCRAFT SERIAL 17261590 AND ON LATER F172 MODELS AND ALL SPARES

BEGINNING WITH SERIALS 17262867 AND F17201240

Figure 15-5. Vacuum System (Sheet 2 of 2)

15-28. TROUBLE SHOOTING--VACUUM PUMP.

TROUBLE	PROBABLE CAUSE	REMEDY
OIL IN DISCHARGE.	Damaged engine drive seal.	Replace gasket.
	Oil separator clogged, oil return line obstructed, excessive oil flow through pump. (F172 Models through F17200804)	Check oil separator, return line: check that pump oil return rate does not exceed 120 cc/hour (approx. 8 drops/minute), at 50 psi oil pressure. Clean oil separator with Stoddard solvent, then blow dry. Blow out lines. If pump oil consumption is excessive, replace oil metering pin in pump.
HIGH SUCTION.	Suction relief valve filter clogged.	Check filter for obstructions. Clean or replace filter.
LOW SUCTION.	Relief valve leaking.	Replace relief valve.
	Vacuum pump failure.	Substitute known-good pump and check pump suction. Replace vacuum pump.
LOW PRESSURE.	Safety valve leaking.	Replace safety valve.
	Vacuum pump failure.	Substitute known-good pump and check pump pressure. Replace vacuum pump.

15-29. REMOVAL AND INSTALLATION OF COMPONENTS. The various components of vacuum system are secured by conventional clamps, mounting screws and nuts. To remove a component, remove mounting screws and disconnect inlet and discharge lines. When replacing a vacuum system component, ensure connections are made correctly. Use no thread lube but teflon tape may be used on male threads. Avoid over tightening connections. Before reinstalling a vacuum pump, place mounting pad gasket in position over studs. On aircraft equipped with wet system only, coat pump drive splines lightly with a high-temperature grease such as Dow Silicone #30 (Dow-Corning Co., Midland, Mich.). After installing pump, before connecting plumbing, start engine and check for evidence of oil in air discharge. The allowable discharge is one to four ounces per hour for a wet system and no discharge is allowable in a dry-type system. Any oil in discharge of a dry system denotes a leaking drive seal.

15-30. CLEANING. In general, low-pressure, dry compressed air should be used in cleaning vacuum system components. Suction relief valve, exposed to engine oil and dirt, should be washed with Stoddard solvent, then dried with a low-pressure air blast. Check hose for collapsed inner liners as well as external damage.

**CAUTION**

Never apply compressed air to lines or components installed in aircraft. The excessive pressures will damage gyros. If an obstructed line is to be blown out, disconnect at both ends and blow from instrument panel out.

15-31. VACUUM RELIEF VALVE ADJUSTMENT. A suction gage reading of 5.3 inches of mercury is desirable for gyro instruments. However, a range of 4.6 to 5.4 inches of mercury is acceptable. To adjust the relief valve, remove control air filter, run engine to 2200 rpm on the ground and adjust relief valve to 5.3 ± .1 inches of mercury.

**CAUTION**

Do not exceed maximum engine temperature.

Be sure filter element is clean before installing. If reading drops noticeably, install new filter element.

15-32. ENGINE INDICATORS.

15-33. TACHOMETER.

15-34. DESCRIPTION. The tachometer used on Cessna single-engine aircraft is a mechanical indicator driven at half crankshaft speed by a flexible shaft. Most tachometer difficulties will be found in the drive-shaft. To function properly, shaft housing must be free of kinks, dents and sharp bends. There should be no bend on a radius shorter than six inches and no bend within three inches of either terminal. If a tachometer is noisy or pointer oscillates, check cable housing for kinks, sharp bends and damage. Disconnect cable at tachometer and pull it out of housing. Check cable for worn spots, breaks and kinks.

NOTE

Before replacing a tachometer cable in housing, coat lower two thirds with AC Type ST-

640 speedometer cable grease or Lubriplate No. 110. Insert cable in housing as far as possible, then slowly rotate to make sure it is seated in engine fitting. Insert cable in tachometer, making sure it is seated in drive shaft, then reconnect housing and torque to 50 pound-inches (at instrument).

15-35. OIL PRESSURE GAGE.

15-36. DESCRIPTION. The Bourdon tube-type oil pressure gage is a direct-reading instrument, operated by a pressure pickup line connected to the engine main oil gallery. The oil pressure line from the instrument to the engine should be filled with kerosene, especially during cold weather operation, to attain an immediate oil indication.

15-37. TROUBLE SHOOTING.

TROUBLE	PROBABLE CAUSE	REMEDY
GAGE DOES NOT REGISTER.	Pressure line clogged.	Check line for obstructions. Clean line.
	Pressure line broken.	Check line for leaks and damage. Repair or replace damaged line.
	Fractured Bourdon tube.	Replace instrument.
	Gage pointer loose on staff.	Replace instrument.
	Damaged gage movement.	Replace instrument.
GAGE POINTER FAILS TO RETURN TO ZERO.	Foreign matter in line.	Check line for obstructions. Clean line.
	Foreign matter in Bourdon tube.	Replace instrument.
	Bourdon tube stretched.	Replace instrument.
GAGE DOES NOT REGISTER PROPERLY.	Faulty mechanism.	Replace instrument.
GAGE HAS ERRATIC OPERATION.	Worn or bent movement.	Replace instrument.
	Foreign matter in Bourdon tube.	Replace instrument.
	Dirty or corroded movement.	Replace instrument.



15-37. TROUBLE SHOOTING. (Cont).

TROUBLE	PROBABLE CAUSE	REMEDY
GAGE HAS ERRATIC OPERATION. (Cont.)	Pointer bent and rubbing on dial, dial screw or glass.	Replace instrument.
	Leak in pressure line.	Check line for leaks and damage. Repair or replace damaged line.

15-38. OIL TEMPERATURE GAGE.

15-39. DESCRIPTION. The oil temperature gage is a Bourdon-type pressure instrument connected by armored capillary tubing to a temperature bulb in the engine. The temperature bulb, capillary tube and gage are filled with fluid and sealed. Expansion and contraction of fluid in the bulb with temperature changes operates gage. Checking capillary tube for damage and fittings for security is the only maintenance required. Since the tube's inside diameter is quite small, small dents and kinks which would be quite acceptable in larger tubing may partially or completely close off capillary, making gage inoperative.

15-40. CARBURETOR AIR TEMPERATURE GAGE.

15-41. DESCRIPTION. The carburetor air temperature gage is of the resistance-bridge type. Changes in electrical resistance of the element are indicated by the gage, calibrated for temperature. The system requires power from the aircraft electrical system and operates only when the master switch is on. Although both instrument and sensing bulb are grounded, two leads are used to avoid possibility of instrument error introduced by poor electrical bonds in the air frame.

15-42. TROUBLE SHOOTING.

TROUBLE	PROBABLE CAUSE	REMEDY
GAGE POINTER STAYS OFF LOW END OF SCALE.	Circuit breaker out.	Check visually. Reset breaker.
	Master switch OFF or switch defective.	Check switch ON. Replace defective switch.
	Broken or grounded leads between gage and sensing unit.	Check circuit wiring. Repair or replace defective wiring.
	Defective gage or sensing unit.	Substitute known-good gage or sensing unit. Replace gage or sensing unit.
GAGE POINTER GOES OFF HIGH END OF SCALE.	Broken or grounded lead.	Check circuit wiring. Repair or replace defective wiring.
	Defective gage or sensing unit.	Substitute known-good gage or sensing unit. Replace gage or sensing unit.
GAGE OPERATES INTERMITTENTLY.	Defective master switch, broken or grounded lead.	Check circuit wiring. Replace switch, repair or replace defective wiring.
	Defective gage or sensing unit.	Substitute known-good gage or sensing unit. Replace gage or sensing unit.

15-42. TROUBLE SHOOTING. (Cont.)

TROUBLE	PROBABLE CAUSE	REMEDY
EXCESSIVE POINTER OSCILLATION. (Cont.)	Loose or broken lead.	Check circuit wiring. Repair or replace defective wiring.
	Defective gage or sensing unit.	Substitute known-good gage or sensing unit. Replace gage or sensing unit.
	Excessive panel vibration.	Check panel shock-mounts. Replace defective shock-mounts.
OBVIOUSLY INCORRECT TEMPERATURE READING.	Defective gage or sensing unit.	Substitute known-good gage or sensing unit. Replace gage or sensing unit.
POINTER FAILS TO GO OFF SCALE WITH CURRENT OFF.	Defective master switch.	Replace switch.
	Defective gage.	Substitute known-good gage. Replace gage.

15-43. FUEL QUANTITY SYSTEM.

15-44. DESCRIPTION. The magnetic type fuel quantity indicators are used in conjunction with a float-operated variable-resistance transmitter in each fuel tank. The full position of float produces a minimum resistance through transmitter, permitting maximum current flow through the fuel quantity indicator and maximum pointer deflection. As fuel level is lowered, resistance in transmitter is increased, producing a decreased current flow through fuel quantity indicator and a smaller pointer deflection.

15-44A. REMOVAL AND INSTALLATION.

a. Drain fuel from tank. (Observe precautions in Section 12.

- b. Remove access plate above fuel tank for access to transmitter.
- c. Disconnect electrical lead and ground strap from transmitter.
- d. Remove screws attaching transmitter and carefully work transmitter from tank. DO NOT BEND FLOAT ARM.
- e. Install transmitter by reversing preceding steps, using new gasket around opening in fuel tank and under screw heads.
- f. Service fuel tanks. Check for leaks and correct quantity indicator.

NOTE

Ensure transmitter is properly grounded in accordance with Section 12.

**SHOP NOTES:**

---



---



---



---



---



---

15-45. TROUBLE SHOOTING.

TROUBLE	PROBABLE CAUSE	REMEDY
FAILURE TO INDICATE.	No power to indicator or transmitter. (Pointer stays below E.)	Check circuit breaker and inspect for open circuit. Reset breaker, repair or replace defective wiring.
	Grounded wire. (Pointer stays above F.)	Check for partial ground between transmitter and gage. Repair or replace defective wire.
	Low voltage.	Check voltage at indicator. Correct voltage.
	Defective indicator.	Substitute known-good indicator. Replace indicator.
OFF CALIBRATION.	Defective indicator.	Substitute known-good indicator. Replace indicator.
	Defective transmitter.	Substitute known-good transmitter. Recalibrate or replace.
	Low or high voltage.	Check voltage at indicator. Correct voltage.
STICKY OR SLUGGISH INDICATOR OPERATION.	Defective indicator.	Substitute known-good indicator. Replace indicator.
	Low voltage.	Check voltage at indicator. Correct voltage.
ERRATIC READINGS.	Loose or broken wiring on indicator or transmitter.	Inspect circuit wiring. Repair or replace defective wire.
	Defective indicator or transmitter.	Substitute known-good component. Replace indicator or transmitter.
	Defective master switch.	Replace switch.

15-46. TRANSMITTER CALIBRATION. Possibility of transmitter calibration changing in normal service is remote, however, it is possible that float arm or float arm stops may become bent if transmitter is removed from the tank. Transmitter calibration is obtained by adjusting float travel. Float travel is limited by the float arm stops.

**WARNING**

Use extreme caution while working with electrical components of the fuel system. The possibility of electrical sparks around an empty fuel tank creates a hazardous situation.

Before installing transmitter, attach electrical wires and place master switch in ON position. Allow the float arm to rest against lower float arm stop and read indicator. The pointer should be on E (empty) position. Adjust lower stop with float arm against stop so that pointer indicator is on E (empty). Raise float arm until it is against upper stop and adjust stop to permit indicator pointer to be on F (full). Install transmitter in accordance with Section 12.

15-47. HOURMETER.

15-48. DESCRIPTION. The hourmeter is electrically operated and is actuated by a pressure switch in the oil pressure system. Electrical power is

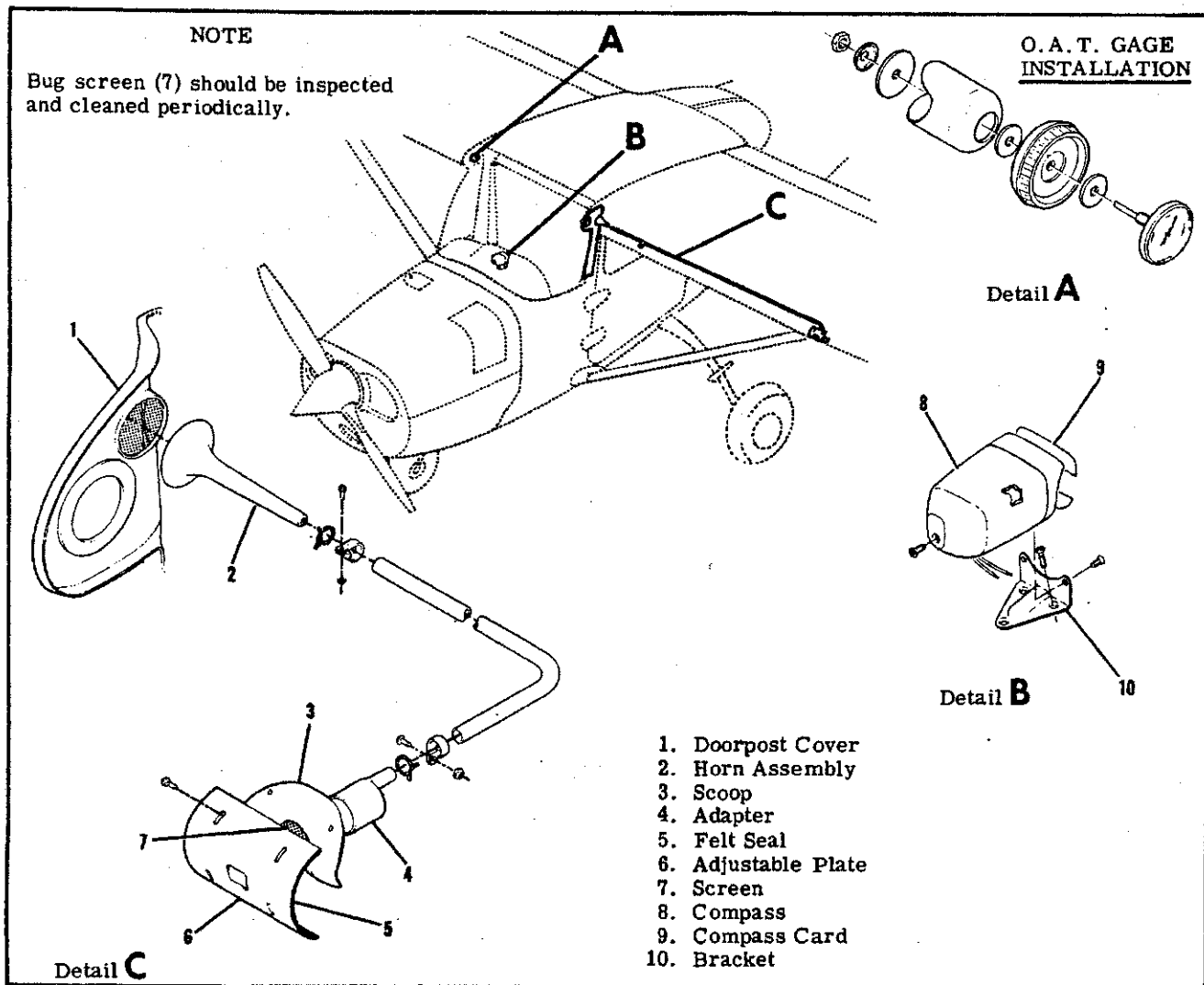

Figure 15-6. Stall Warning System and Compass Installation

supplied through a one-amp fuse from the electrical clock circuit and therefore, will operate independent of the master switch. If no clock is installed, a line direct from the battery contactor provides power independent of the master switch through a one-amp fuse located adjacent to the battery box. An indicator on the dial face rotates when the meter is actuated. If the meter is inoperative and clock is operating, the meter or its wiring is faulty and must be replaced.

15-49. MAGNETIC COMPASS. (Refer to figure 15-6.)

15-50. DESCRIPTION. The magnetic compass is liquid-filled, with expansion provisions to compensate for temperature changes. It is equipped with compensating magnets adjustable from front of case. The compass is internally lighted, controlled by the panel lights rheostat. No maintenance is required on compass except on occasional check on a compass rose for adjustment of compensation and replacement of lamp.

15-51. STALL WARNING SYSTEM. (Refer to figure 15-6.)

15-52. DESCRIPTION. The system is composed of an adjustable plate on left wing leading edge, connected to a reed type horn by means of plastic tubing. The horn is actuated approximately 5 to 10 miles per hour above stalling speed as a negative air pressure area at wing leading edge causes a reverse flow of air through horn. By moving adjustable plate (6) up, actuation of horn will occur at a higher speed and moving plate down causes actuation to occur at a slower speed. Center adjustable plate opening in wing leading edge upon installation, then flight test aircraft, observing horn actuation during stall. Re-adjust plate to obtain desired results if necessary. Approximately 3/32 inch adjustment of plate will change speed at which horn actuation occurs by 5 miles per hour. To test horn operation, cover opening in plate (6) with a clean cloth, such as a handkerchief and apply a slight suction by mouth to draw air through horn.

15-53. TURN COORDINATOR.

15-54. DESCRIPTION. The turn coordinator is an electrically operated, gyroscopic, roll-rate turn indicator. Its gyro simultaneously senses rate of

motion roll and yaw axes which is projected on a single indicator. The gyro is a non-tumbling type requiring no caging mechanism and incorporates an a. c. brushless spin motor with a solid state inverter.

15-55. TROUBLE SHOOTING.

TROUBLE	PROBABLE CAUSE	REMEDY
INDICATOR DOES NOT RETURN TO CENTER.	Friction caused by contamination in the indicator damping.	Replace instrument.
	Friction in gimbal assembly.	Replace instrument.
DOES NOT INDICATE A STANDARD RATE TURN (TOO SLOW).	Low voltage.	Measure voltage at instrument. Correct voltage.
	Inverter frequency changed.	Replace instrument.
NOISY MOTOR.	Faulty bearings.	Replace instrument.
ROTOR DOES NOT START.	Faulty electrical connection.	Check continuity and voltage. Correct voltage or replace faulty wire.
	Inverter malfunctioning.	Replace instrument.
	Motor shorted.	Replace instrument.
	Bearings frozen.	Replace instrument.
IN COLD TEMPERATURES, HAND FAILS TO RESPOND OR IS SLUGGISH.	Oil in indicator becomes too thick.	Replace instrument.
	Insufficient bearing end play.	Replace instrument.
	Low voltage.	Check voltage at instrument. Correct voltage.
NOISY GYRO.	High voltage.	Check voltage to instrument. Correct voltage.
	Loose or defective rotor bearings.	Replace instrument.

15-56. TURN-AND-SLIP INDICATOR.

is an electrically operated instrument powered by the aircraft electrical system, therefore, operating only when the master switch is ON.

15-57. DESCRIPTION. The turn-and-slip indicator

15-58. TROUBLE SHOOTING.

TROUBLE	PROBABLE CAUSE	REMEDY
INDICATOR POINTER FAILS TO RESPOND.	Internal fuse blown.	Check wiring for continuity, check voltage at indicator. Replace fuse, if fuse still blows, replace instrument.
	Master switch "OFF" or switch defective.	Check switch "ON." Replace defective switch.
	Broken or grounded lead to indicator.	Check circuit wiring. Repair or replace defective wiring.
	Indicator not grounded.	Check ground wire. Repair or replace defective wire.
	Defective mechanism.	Replace instrument.
HAND SLUGGISH IN RETURNING TO ZERO.	Defective mechanism.	Replace instrument.
	Low voltage.	Check voltage at indicator. Correct voltage.
POINTER DOES NOT INDICATE PROPER TURN.	Defective mechanism.	Replace instrument.
HAND DOES NOT SIT ON ZERO.	Gimbal and rotor out of balance.	Replace instrument.
	Hand incorrectly sits on rod.	Replace instrument.
	Sensitivity spring adjustment pulls hand off zero.	Replace instrument.
IN COLD TEMPERATURES, HAND FAILS TO RESPOND OR IS SLUGGISH.	Oil in indicator becomes too thick.	Replace instrument.
	Insufficient bearing end play.	Replace instrument.
	Low voltage.	Check voltage at indicator. Correct voltage.
NOISY GYRO.	High voltage.	Check voltage at indicator. Correct voltage.
	Loose or defective rotor bearings.	Replace instrument.

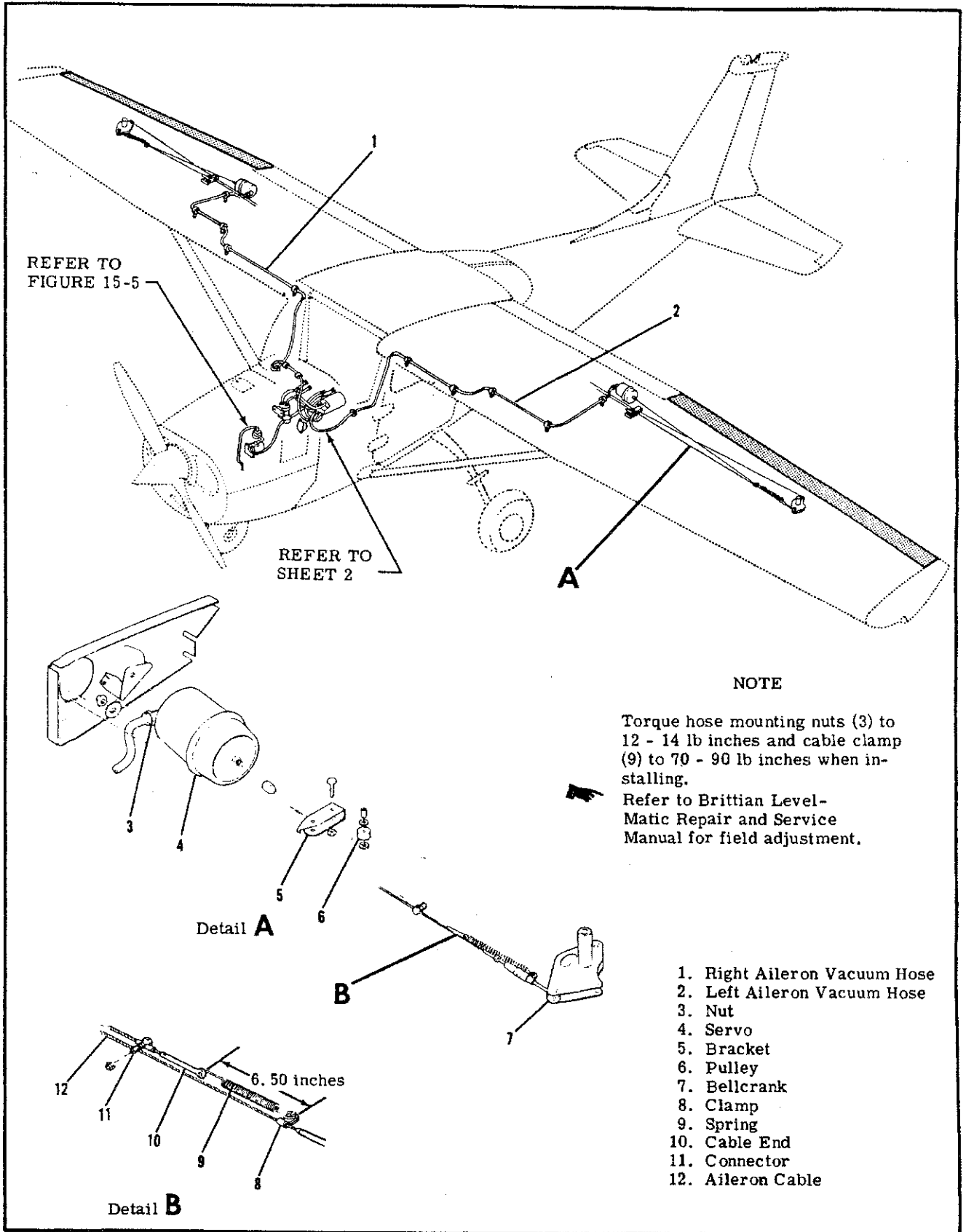
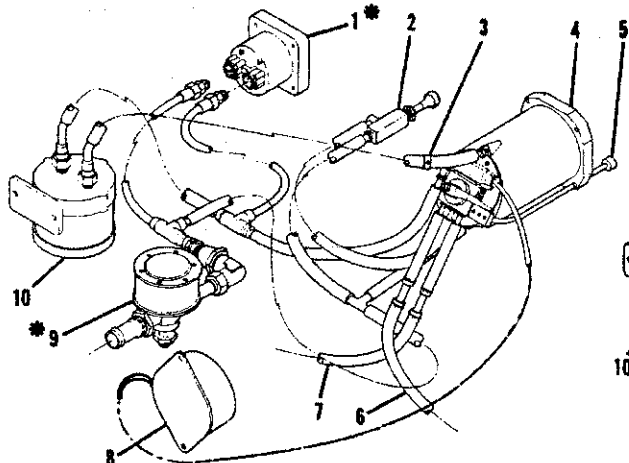
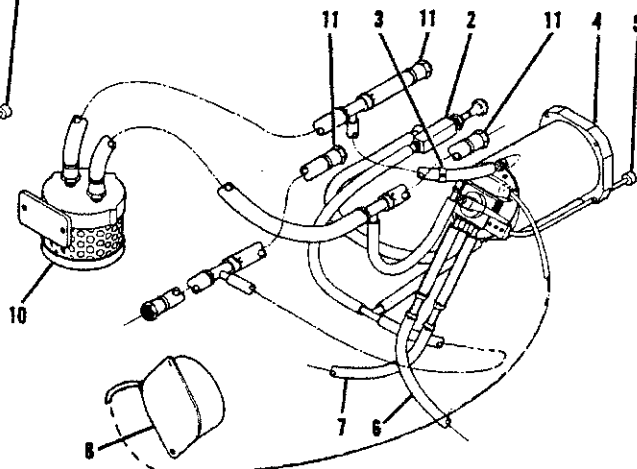

Figure 15-7. Wing Leveler Control System (Sheet 1 of 2)



**USED WITHOUT GYROS**  
**THRU SERIALS 17257164**  
**AND F17200804**



**USED WITH GYROS**  
**THRU SERIALS 17257165**  
**AND F17200804**

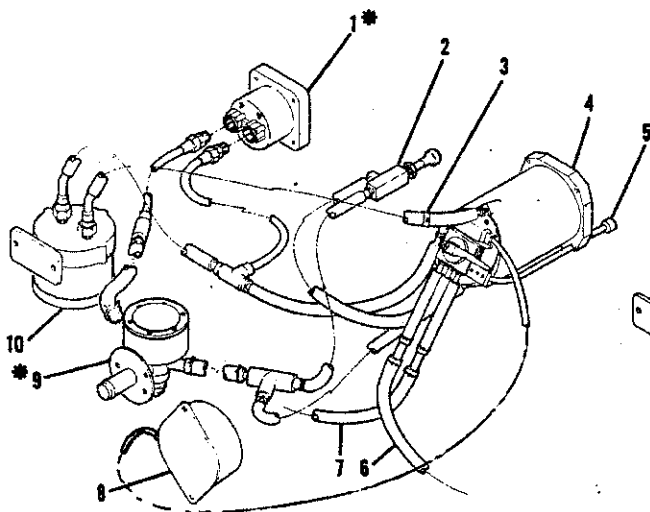

**USED WITHOUT GYROS**  
**SERIALS 17257165 THRU 17261898**  
**AND F17200805 THRU F17201234**

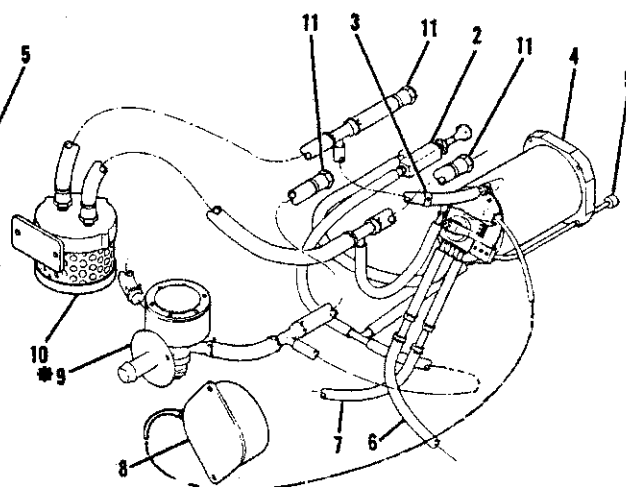

**USED WITH GYROS**  
**SERIALS 17257165 THRU 17261898**  
**AND F17200805 THRU F17201234**

**NOTE**

Restrictor Valve (3), inverter (8) and turn coordinator (4) must be replaced as a matched set.

\* Refer to figure 15-5.

1. Suction Gage
2. ON-OFF Control
3. Restrictor Valve
4. Turn Coordinator
5. Roll Trim Knob
6. Left Aileron Vacuum Hose
7. Right Aileron Vacuum Hose
8. Inverter
9. Vacuum Relief Valve
10. Filter
11. Gyro Hose

Figure 15-7. Wing Leveler Control System (Sheet 2 of 2)



15-59. WING LEVELER. THRU SERIALS 17261898 AND F17201234. (Refer to figure 15-7)

15-60. DESCRIPTION. The wing leveler control system, consisting of a turn coordinator, pneumatic servos, connecting cables and hose may be installed. The turn coordinator gyro senses changes in roll attitude, then electrically meters vacuum power from the engine-driven vacuum pump to the cylinder-piston servos, operating ailerons for longitudinal stability. Manual control of system is afforded by the roll trim knob. Roll trim should not be used to correct faulty rigging or "wing heaviness." Manual override of system may be accomplished without damage to aircraft or system. The ON-OFF valve controls vacuum supply to distributor valve, but does not affect electrically operated turn coordinator gyro. Installation of wing leveler does not change vacuum relief valve settings. Refer to appropriate

publication issued by the manufacturer for trouble shooting procedures.

15-61. RIGGING.

- a. Loosen connector (12) and clamp (9).
- b. Move aileron to full up position.
- c. Move clamp (9) outboard until spring (10) is extended to 6.50 inches from hole in servo cable end to hole in clamp and tighten screw and nut.

NOTE

After completion of step "c", servo seal should be taut but not stretched.

- d. Move connector (12) outboard until sleeve contacts servo cable end, then back off approximately .06 inch and torque connector to 70-90 pound-inches.



## SECTION 16

## ELECTRICAL SYSTEMS

TABLE OF CONTENTS	Page		Page
ELECTRICAL SYSTEMS . . . . .	16-2	Removal and Installation . . . . .	16-22A
General . . . . .	16-2	Landing and Taxi Lights	
Electrical Power Supply System . . . . .	16-2	(Cowl Mounted) . . . . .	16-22A
Description . . . . .	16-2	Description . . . . .	16-22A
Split Bus Bar . . . . .	16-2	Removal and Installation (Thru	
Description . . . . .	16-2	Aircraft Serial F17200881 . . . . .	16-22A
Split Bus Power Relay . . . . .	16-2	Removal and Installation (Begin-	
Description . . . . .	16-2	ning With Aircraft Serials	
Master Switch . . . . .	16-2	17260759 And F17200882) . . . . .	16-22A
Description . . . . .	16-2	Adjustment (Thru Aircraft Serials	
Ammeter . . . . .	16-2	17259737 And F17200804) . . . . .	16-22A
Description . . . . .	16-2	Adjustment (Beginning With	
Battery Power System . . . . .	16-2	Aircraft Serials 17259738	
Battery . . . . .	16-2	And F17200805 . . . . .	16-22B
Description . . . . .	16-2	Landing and Taxi Lights	
Trouble Shooting . . . . .	16-3	(Cowl Mounted) (Dual) . . . . .	16-22B
Removal and Installation . . . . .	16-3	Description . . . . .	16-22B
Cleaning the Battery . . . . .	16-3	Removal and Installation . . . . .	16-22B
Adding Electrolyte or Water		Navigation Lights . . . . .	16-22B
to Battery . . . . .	16-3	Description . . . . .	16-22B
Testing the Battery . . . . .	16-3	Removal and Installation . . . . .	16-22B
Charging the Battery . . . . .	16-3	Anti-Collision Strobe Light . . . . .	16-22B
Battery Box . . . . .	16-6	Description . . . . .	16-22B
Description . . . . .	16-6	Removal and Installation . . . . .	16-22B
Removal and Installation . . . . .	16-6	Flashing Beacon . . . . .	16-22B
Maintenance of Battery Box . . . . .	16-6	Description . . . . .	16-22B
Battery Contactor . . . . .	16-6	Removal and Installation . . . . .	16-22B
Description . . . . .	16-6	Instrument, Dome and Courtesy	
Removal and Installation . . . . .	16-6	Lights . . . . .	16-22B
Battery Contactor Closing		Description . . . . .	16-22B
Circuit . . . . .	16-6	Removal and Installation . . . . .	16-28
Description . . . . .	16-6	Compass and Radio Dial Lighting . . . . .	16-28
Ground Service Receptacle . . . . .	16-6	Description . . . . .	16-28
Description . . . . .	16-6	Transistorized Light Dimming . . . . .	16-28
Trouble Shooting . . . . .	16-6	Description . . . . .	16-28
Removal and Installation . . . . .	16-9	Removal and Installation . . . . .	16-28
Alternator Power System . . . . .	16-9	Map Lighting . . . . .	16-28
Description . . . . .	16-9	Description . . . . .	16-28
Alternator . . . . .	16-9	Removal and Installation . . . . .	16-28
Description . . . . .	16-9	Control Wheel Map Light . . . . .	16-31
Trouble Shooting the Alternator		Description . . . . .	16-31
System . . . . .	16-9	Removal and Installation (Thru	
Removal and Installation of		1970 Models) . . . . .	16-31
Gear Driver Alternator . . . . .	16-11	Removal and Installation (Begin-	
Removal and Installation		ning With 1971 Models) . . . . .	16-31
Belt Driven Alternator . . . . .	16-11	Pitot Heater . . . . .	16-31
Alternator Field Circuit		Description . . . . .	16-31
Protection . . . . .	16-12	Cigar Lighter . . . . .	16-31
Over-Voltage Warning System . . . . .	16-12	Description . . . . .	16-31
Description . . . . .	16-12	Emergency Locator Transmitter . . . . .	16-32
Alternator Voltage Regulator . . . . .	16-12	Description . . . . .	16-32
Description . . . . .	16-12	Operation . . . . .	16-32
Trouble Shooting . . . . .	16-12	Checkout Interval . . . . .	16-32
Removal and Installation . . . . .	16-12	Removal and Installation of	
Aircraft Lighting System . . . . .	16-15	Transmitter . . . . .	16-34
Description . . . . .	16-15	Removal and Installation of	
Trouble Shooting . . . . .	16-15	Antenna . . . . .	16-34
Landing and Taxi Lights		Removal and Installation of	
(Wing Mounted) . . . . .	16-22A	Magnesium Six Cell Battery Pack . . . . .	16-34
Description . . . . .	16-22A	Removal and Installation of	
		Lithium Four Cell Battery Pack . . . . .	16-34
		Trouble Shooting . . . . .	16-35
		Electrical Load Analysis Chart . . . . .	16-37

16-1. ELECTRICAL SYSTEMS.

16-2. GENERAL. This section contains service information necessary to maintain the Aircraft Electrical Power Supply System, Aircraft Lighting System, Pitor Heater, Cigar Lighter and Electrical Load Analysis Chart.

16-3. ELECTRICAL POWER SUPPLY SYSTEM.

16-4. DESCRIPTION. Electrical energy for the aircraft is supplied by a 12-volt, direct current, single-wire, negative ground electrical system. A single 12-volt battery supplies power for starting and furnishes a reserve source of power in the event of alternator failure. An engine-driven alternator is the normal source of power during flight and maintains a battery charge controlled by a voltage regulator. An external power receptacle is offered as optional equipment to supplement the battery system for starting and ground operation.

16-5. SPLIT BUS BAR.

16-6. DESCRIPTION. Electrical power is supplied through a split bus bar. One side of the bus bar supplies power to the electrical equipment while the other side supplies the electronic installations. When the master switch is closed, the battery contactor engages and the battery power is supplied to the electrical side of the split bus bar. The electrical bus feeds battery power to the electronics bus through a normally closed relay; this relay opens when the starter switch is engaged or when an external power source is used, preventing transient voltages from damaging the semiconductor circuitry in the electronic installations.

16-7. SPLIT BUS POWER RELAY.

16-8. DESCRIPTION. A power relay is installed behind the instrument panel on all aircraft utilizing a split bus bar. The relay is a normally closed type, opening when external power is connected or when the

starter is engaged, thus removing battery power from the electronic side of the split bus and preventing transient voltages from damaging the electronic installations.

16-9. MASTER SWITCH

16-10. DESCRIPTION. On 1969 models the operation of the battery and alternator systems is controlled by a master switch. The switch is a pull type with double-pole, single-throw contacts. The switch, when operated, connects the battery contactor coil to ground and the alternator field circuit to the battery, activating the power systems. On 1970 models and on, a new master switch is utilized. This switch is a interlocking split rocker with the battery mode on the right hand side and the alternator mode on the left hand side. This arrangement allows the battery to be on the line without the alternator, however, operation of the alternator without the battery on the line is not possible. The switch is labeled "BAT" and "ALT" below the switch and is located on the left hand side of the switch panel.

16-11. AMMETER.

16-12. DESCRIPTION. The ammeter is connected between the battery and the aircraft bus. The meter indicates the amount of current flowing either to or from the battery. With a low battery and the engine operating at cruise speed, the ammeter will show the full alternator output. When the battery is fully charged and cruise is maintained with all electrical equipment off, the ammeter will show a minimum charging rate.

16-13. BATTERY POWER SYSTEM.

16-14. BATTERY.

16-15. DESCRIPTION. The battery is 12 volts and is approximately 25 ampere-hour capacity. The battery is mounted on the forward side of the firewall and is equipped with non-spill filler caps.

**SHOP NOTES:**

---

---

---

---

---

---

---

---

---

---

16-16. TROUBLE SHOOTING THE BATTERY POWER SYSTEM.

TROUBLE	PROBABLE CAUSE	REMEDY
<p>BATTERY WILL NOT SUPPLY POWER TO BUS OR IS INCAPABLE OF CRANKING ENGINE.</p>	<p>Battery discharged.</p>	<p>1. Measure voltage at "BAT" terminal of battery contactor with master switch and a suitable load such as a taxi light turned on. Normal battery will indicate 11.5 volts or more. If voltage is low, proceed to step 2. If voltage is normal, proceed to step 3.</p>
	<p>Battery faulty.</p>	<p>2. Check fluid level in cells and charge battery at 20 amps for approximately 30 minutes or until the battery voltage rises to 15 volts. Check battery with a load type tester. If tester indicates a good battery, the malfunction may be assumed to be a discharged battery. If the tester indicates a faulty battery, replace the battery.</p>
	<p>Faulty contactor or wiring between contactor or master switch.</p>	<p>3. Measure voltage at master switch terminal (smallest) on contactor with master switch closed. Normal indication is zero volts. If voltage reads zero, proceed to step 4. If a voltage reading is obtained check wiring between contactor and master switch. Also check master switch.</p>
	<p>Open coil on contactor.</p>	<p>4. Check continuity between "BAT" terminal and master switch terminal of contactor. Normal indication is 16 to 24 ohms (Master switch open). If ohmmeter indicates an open coil, replace contactor. If ohmmeter indicates a good coil, proceed to step 5.</p>
	<p>Faulty contactor contacts.</p>	<p>5. Check voltage on "BUS" side of contactor with master switch closed. Meter normally indicates battery voltage. If voltage is zero or intermittent, replace contactor. If voltage is normal, proceed to step 6.</p>
	<p>Faulty wiring between contactor and bus.</p>	<p>6. Inspect wiring between contactor and bus. Repair or replace wiring.</p>

16-17. REMOVAL AND INSTALLATION. (Refer to figure 16-1.)

- a. Remove top half of cowl.
- b. Remove the battery box cover.
- c. Disconnect the ground cable from the negative battery terminal.

**CAUTION**

- When installing or removing battery always observe the proper polarity with the aircraft electrical system (negative to ground). reversing the polarity, even momentarily, may result in failure of semiconductor devices (alternator diodes, radio protection diodes and radio transistors).
- Always remove the battery ground cable first and replace it last to prevent accidental short circuits.
- d. Disconnect the cable from the positive terminal of the battery.
- e. Lift the battery out of the battery box.
- f. To replace the battery, reverse this procedure.

16-18. CLEANING THE BATTERY. For maximum efficiency the battery and connections should be kept clean at all times.

- a. Remove the battery and connections in accordance with the preceding paragraph.
- b. Tighten battery cell filler caps to prevent the cleaning solution from entering the cells.
- c. Wipe the battery cable ends, battery terminals and the entire surface of the battery with a clean cloth moistened with a solution of bicarbonate of soda (baking soda) and water.
- d. Rinse with clear water, wipe off excess water and allow battery to dry.
- e. Brighten up cable ends and battery terminals with emery cloth or a wire brush.
- f. Install the battery according to the preceding paragraph.
- g. Coat the battery terminals with petroleum jelly or an ignition spray product to reduce corrosion.

16-19. ADDING ELECTROLYTE OR WATER TO THE BATTERY. A battery being charged and discharged with use will decompose the water from the electrolyte by electrolysis. When the water is decomposed hydrogen and oxygen gases are formed which escape into the atmosphere through the battery vent system. The acid in the solution chemically combines with the plates of the battery during discharge or is suspended in the electrolyte solution during charge. Unless the electrolyte has been spilled from a battery, acid should not be added to the solution. The water, however will decompose into gases and should be replaced regularly. Add distilled water as necessary to maintain the electrolyte level with the horizontal baffle plate or the split ring on the filler neck inside the battery. When "dry charged" batteries are put into service fill as directed with electrolyte. When the electrolyte level falls below normal with use, add

only distilled water to maintain the proper level. The battery electrolyte contains approximately 25% sulphuric acid by volume. Any change in this volume will hamper the proper operation of the battery.

**CAUTION**

Do not add any type of "battery rejuvenator" to the electrolyte. When acid has been spilled from a battery, the acid balance may be adjusted by following instructions published by the Association of American Battery Manufacturers.

16-20. TESTING THE BATTERY. The specific gravity of the battery may be measured with a hydrometer to determine the state of battery charge. If the hydrometer reading is low, slow-charge the battery and retest. Hydrometer readings of the electrolyte must be compensated for the temperature of the electrolyte. Some hydrometers have a built-in thermometer and conversion chart. The following chart shows the battery condition for various hydrometer readings with an electrolyte temperature of 80° Fahrenheit.

**BATTERY HYDROMETER READINGS**

READINGS	BATTERY CONDITION
1.280 Specific Gravity .....	100% Charged
1.250 Specific Gravity .....	75% Charged
1.220 Specific Gravity .....	50% Charged
1.190 Specific Gravity .....	25% Charged
1.160 Specific Gravity .....	Practically Dead

**NOTE**

All readings shown are for an electrolyte temperature of 80° Fahrenheit. For higher temperatures the readings will be slightly lower. For cooler temperatures the readings will be slightly higher. Some hydrometers will have a built-in temperature compensation chart and a thermometer. If this type tester is used, disregard this chart.

16-21. CHARGING THE BATTERY. When the battery is to be charged, the level of the electrolyte should be checked and adjusted by adding distilled water to cover the tops of the internal battery plates. Remove the battery from the aircraft and place in a well ventilated area for charging.

Note

Starter contactor is located on right hand side of the firewall on F172 models.

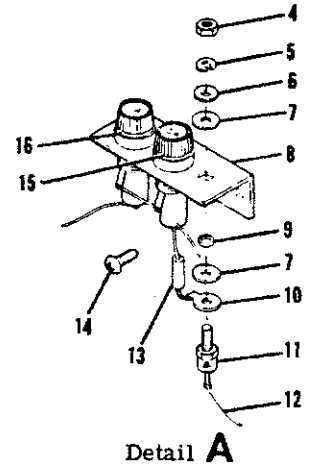
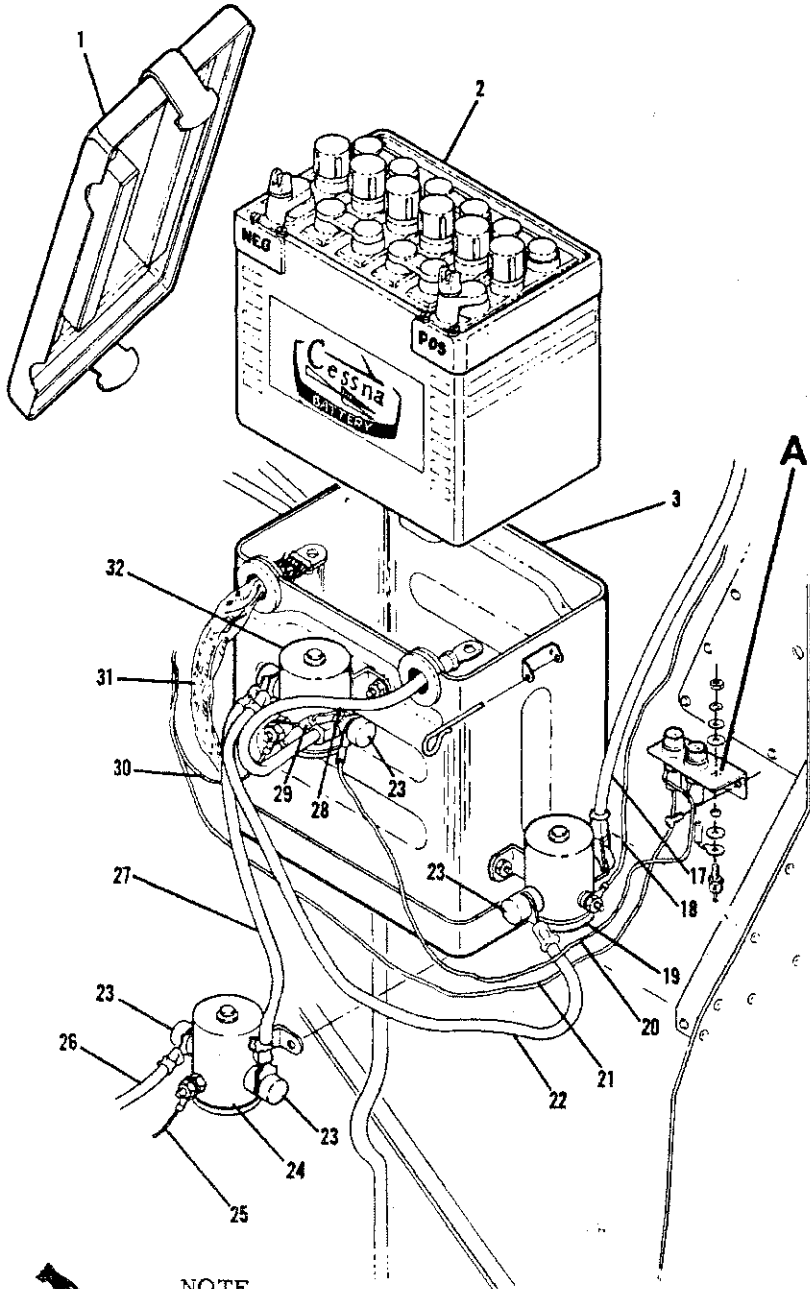

1. Battery Box Lid
2. Battery
3. Battery Box
4. Nut
5. Lockwasher
6. Washer
7. Insulating Washer
8. Bracket
9. Spacer
10. Solder Terminal
11. Diode
12. Wire to Battery Contactor
13. Resistor
14. Screw
15. Fuse - Battery Contactor Closing Circuit
16. Fuse - Clock
17. Wire to Ground Service Receptacle
18. Wire to Diode Board
19. Ground Service Receptacle Contactor
20. Wire from Fuse to Battery Contactor
21. Wire to Clock
22. Wire from Starter Contactor to Battery Contactor
23. Cover
24. Starter Contactor
25. Wire to Ignition Switch
26. Wire to Starter
27. Wire from Starter Contactor to Battery Contactor
28. Positive Battery Lead
29. Diode Assembly
30. Wire to Master Switch
31. Negative Ground Strap
32. Battery Contactor

NOTE

BEGINNING WITH AIRCRAFT SERIALS 17260858 AND F17200945 a vented battery contactor is installed.

Figure 16-1. Battery and Electrical Equipment Installations

## **WARNING**

When a battery is being charged, hydrogen and oxygen gases are generated. Accumulation of these gases can create a hazardous explosive condition. Always keep sparks and open flame away from the battery.

Allow unrestricted ventilation of the battery area during charging.

The main points of consideration during a battery charge are excessive battery temperature and violent gassing. Test the battery with a hydrometer to determine the amount of charge. Decrease the charging rate or stop charging temporarily if the battery temperature exceeds 125°F.

### 16-22. BATTERY BOX.

16-23. DESCRIPTION. The battery is completely enclosed in a box which is painted with acid proof paint. The box has a vent tube which protrudes through the bottom of the aircraft allowing battery gases and spilled electrolyte to escape. The battery box is riveted to the forward side of the firewall.

16-24. REMOVAL AND INSTALLATION. (Refer to figure 16-1.) The battery box is riveted to mounting brackets on the firewall. The rivets must be drilled out to remove the box. When a battery box is installed and riveted into place, all rivets and scratches inside the box should be painted with acidproof lacquer Part No. CES1054-381, available from the Cessna Service Parts Center.

16-25. MAINTENANCE OF BATTERY BOX. The battery box should be inspected and cleaned periodically. The box and cover should be cleaned with a strong solution of bicarbonate of soda (baking soda) and water. Hard deposits may be removed with a wire brush. When all corrosive deposits have been removed from the box, flush it thoroughly with clean water.

## **WARNING**

Do not allow acid deposits to come in contact with skin or clothing. Serious acid burns may result unless the affected area is washed immediately with soap and water. Clothing will be ruined upon contact with battery acid.

Inspect the cleaned box and cover for physical damage and for areas lacking proper acid proofing. A badly damaged or corroded box should be replaced. If the box or lid require acid proofing, paint the area with acid proof lacquer Part No. CES1054-381, available from the Cessna Service Parts Center.

### 16-26. BATTERY CONTACTOR.

16-27. DESCRIPTION. The battery contactor is bolted to the side of the battery box. The contactor is a plunger type contactor which is actuated by turning the master switch on. When the master switch is

off, the battery is disconnected from the electrical system. A silicon diode is used to eliminate spiking of transistorized radio equipment. The large terminal of the diode connects to the battery terminal of the battery contactor. The small terminal of the diode and the master switch wire connect to the minus terminal of the contactor coil. A nylon cover is installed on the contactor terminals to prevent accidental short circuits. (See figure 16-1.)

16-28. REMOVAL AND INSTALLATION. (Refer to figure 16-1.)

a. Open battery box and disconnect ground cable from negative battery terminal. Pull cable clear of battery box.

b. Remove the nut, lockwasher and the two plain washers securing the battery cables to the battery contactor.

c. Remove the nut, lockwasher and the two plain washers securing the wire which is routed to the master switch.

d. Remove the bolt, washer and nut securing each side of the battery contactor to the battery box. The contactor will now be free for removal.

e. To replace the contactor, reverse this procedure.

### 16-29. BATTERY CONTACTOR CLOSING CIRCUIT.

16-30. DESCRIPTION. This circuit consists of a 5 amp fuse, a resistor and a diode located on the firewall fuse bracket adjacent to the battery. This serves to shunt a small charge around the battery contactor so that ground power may be used to close the contactor when the battery is too dead to energize the contactor by itself.

### 16-31. GROUND SERVICE RECEPTACLE.

16-32. DESCRIPTION. A ground service receptacle is offered as optional equipment to permit use of external power for cold weather starting or when performing lengthy electrical maintenance. A reverse polarity protection system is utilized whereby ground power must pass through an external power contactor to be connected to the bus. A silicon junction diode is connected in series with the coil on the external power contactor so that if the ground power source is inadvertently connected with a reverse polarity, the external power contactor will not close. This feature protects the diodes in the alternator, and other semiconductor devices used in the airplane, from possible reverse polarity damage.

### NOTE

Maintenance of the electronic installation cannot be performed when using external power. Application of external power opens the relay supplying voltage to the electronics bus. For lengthy ground testing of electronic systems, connect a well regulated and filtered power supply directly to the battery side of the battery contactor. Adjust the supply for 14 volts and close the master switch.



NOTE

When using ground power to start the airplane, close the master switch before removing the ground power plug. This will ensure closure of the battery contactor and excitation of the alternator field in the event that the battery is completely dead.

Failure to observe polarity when connecting an external power source directly to the battery or directly to the battery side of the battery contactor will damage the diodes in the alternator and other semiconductor devices used in the airplane.

16-33. TROUBLE SHOOTING

TROUBLE	PROBABLE CAUSE	REMEDY
STARTER ENGAGES WHEN GROUND POWER IS CONNECTED.	Shorted or reversed diode in split bus-bar system.	Check wiring to, and condition of diode mounted on the split bus relay bracket adjacent to the magneto switch. Correct wiring. Replace diode board assembly.
GROUND POWER WILL NOT CRANK ENGINE.	Ground service connector wired incorrectly.	1. Check for voltage at all three terminals of external power contactor with ground power connected and master switch off. If voltage is present on input and coil terminals but not on the output terminal, proceed to step 4. If voltage is present on the input terminal but not on the coil terminal, proceed to step 2. If voltage is present on all three terminals, check wiring between contactor and bus.  2. Check for voltage at small terminal of ground service receptacle. If voltage is not present, check ground service plug wiring. If voltage is present, proceed to step 3.
	Open or mis-wired diode on ground service diode board assembly.	3. Check polarity and continuity of diode on diode board at rear of ground service receptacle. If diode is open or improperly wired, replace diode board assembly.
	Faulty external power contactor.	4. Check resistance from small (coil) terminal of external power contactor to ground (master switch off and ground power unplugged). Normal indication is 16-24 ohms. If resistance indicates an open coil, replace contactor. If resistance is normal, proceed to step 5.

16-33. TROUBLE SHOOTING (Cont).

TROUBLE	PROBABLE CAUSE	REMEDY
GROUND POWER WILL NOT CRANK ENGINE (Cont).	Faulty contacts in external power contactor.	5. With master switch off and ground power applied, check for voltage drop between two large terminals of external power (turn on taxi light for a load). Normal indication is zero volts. If voltage is intermittently present or present all the time, replace contactor.

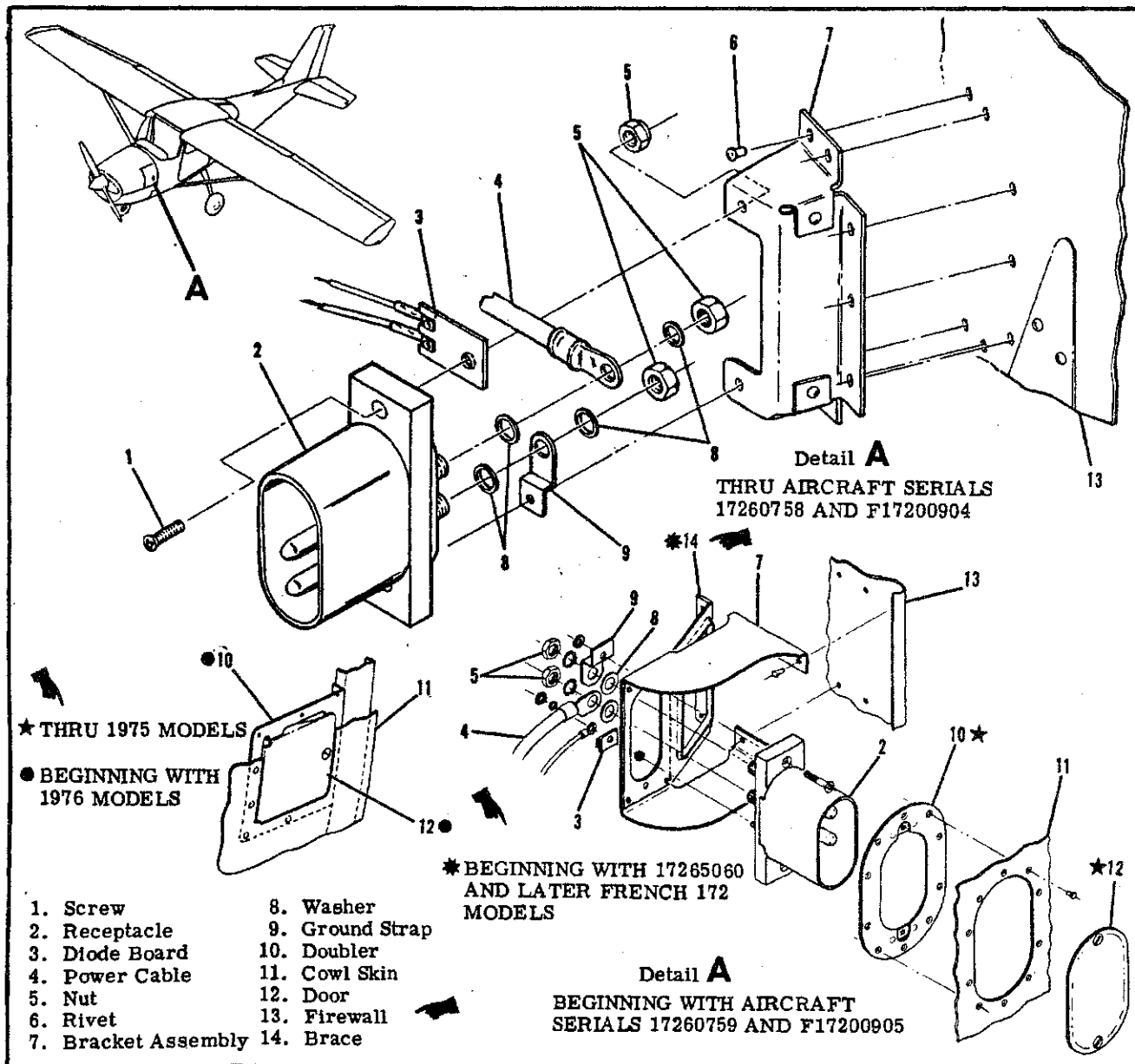

Figure 16-2. Ground Service Receptacle Installation

16-34. REMOVAL AND INSTALLATION. (Refer to figure 16-2.)

- a. Open battery box and disconnect the ground cable from the negative terminal of the battery and pull the cable from the battery box.
- b. Remove the nuts, washers, ground strap and diode board from the studs of the receptacle and remove the battery cable.
- c. Remove the screws and nuts holding the receptacle. The receptacle will then be free from the bracket.
- d. To install a ground service receptacle, reverse this procedure. Be sure to place the ground strap on the negative stud of the receptacle.

16-35. ALTERNATOR POWER SYSTEM.

16-36. DESCRIPTION. The alternator system consists of an engine driven alternator, a voltage regulator mounted on the left hand side of the firewall and a circuit breaker located on the instrument panel. The system is controlled by the left hand portion of the split rocker, master switch labeled "ALT." Beginning with 1972 models an over-voltage sensor switch and red warning light labeled "HIGH VOLTAGE" are incorporated to protect the system, (refer to para-

graph 16-42). The aircraft battery supplies the source of power for excitation of the alternator.

16-37. ALTERNATOR.

16-38. DESCRIPTION. The 60-ampere alternators used on the 172 model are three phase, delta connected with integral silicon diode rectifiers. The alternator is rated at 14 volts at 60 amperes continuous output. The moving center part of the alternator (rotor) consists of an axial winding with radial interlocking poles which surround the winding. With excitation applied to the winding through slip rings the pole pieces assume magnetic polarity. The rotor is mounted in bearings and rotates inside the stator which contains the windings in which ac is generated. The stator windings are three-phase, delta connected and are attached to two diode plates, each of which contain three silicon diodes.

The diode plates are connected to accomplish full-wave, rectification of ac. The resulting dc output is applied to the aircraft bus and sensed by the voltage regulator. The regulator controls the excitation applied to the alternator field, thus controlling the output voltage of the alternator.

16-39. TROUBLE SHOOTING THE ALTERNATOR SYSTEM

TROUBLE	PROBABLE CAUSE	REMEDY
<p>AMMETER INDICATES HEAVY DISCHARGE WITH ENGINE NOT RUNNING OR ALTERNATOR CIRCUIT BREAKER OPENS WHEN MASTER SWITCH IS TURNED ON.</p>	<p>Shorted radio noise filter or shorted wire.</p>	<p>1. Remove cable from output terminal of alternator. Check resistance from end of cable to ground (MASTER SWITCH MUST BE OFF). If resistance does not indicate a direct short, proceed to step 4. If resistance indicates a direct short, proceed to step 2.</p>
		<p>2. Remove cable connections from radio noise filter. Check resistance from the filter input terminal to ground. Normal indication is infinite resistance. If reading indicates a direct short, replace filter. If no short is evident, proceed to step 3.</p>
		<p>3. Check resistance from ground to the free ends of the wires which were connected to the radio noise filter (or alternator if no noise filter is installed). Normal indication does not show a direct short. If a short exists in wires, repair or replace wiring.</p>

16-39. TROUBLE SHOOTING THE ALTERNATOR SYSTEM (Cont.)

TROUBLE	PROBABLE CAUSE	REMEDY
<p>AMMETER INDICATES HEAVY DISCHARGE WITH ENGINE NOT RUNNING OR ALTERNATOR CIRCUIT BREAKER OPENS WHEN MASTER SWITCH IS TURNED ON (Cont).</p>	<p>Shorted diodes in alternator.</p>	<p>4. Check resistance from output terminal of alternator to alternator case. Reverse leads and check again. Resistance reading may show continuity in one direction but should show an infinite reading in the other direction. If an infinite reading is not obtained in at least one direction, repair or replace alternator.</p>
<p>ALTERNATOR SYSTEM WILL NOT KEEP BATTERY CHARGED.</p>	<p>Regulator faulty or improperly adjusted.</p>	<p>1. Start engine and adjust for 1500 RPM. Ammeter should indicate a heavy charge rate with all electrical equipment turned off. Rate should taper off in 1-3 minutes. A voltage check at the bus should indicate a reading consistent with the voltage vs temperature chart on page 16-10. If charge rate tapers off very quickly and voltage is normal, check battery for malfunction. If ammeter shows a low charge rate or any discharge rate, and voltage is low, proceed to step 2.</p> <p>2. Stop engine, remove cowl, and remove cover from voltage regulator. Turn master switch ON/OFF several times and observe field relay in regulator. Relay should open and close with master switch and small arc should be seen as contacts open. If relay is inoperative, proceed to step 3. If relay operates, proceed to step 4.</p> <p>3. Check voltage at "S" terminal of regulator with master switch closed. Meter should indicate bus voltage. If voltage is present, replace regulator. If voltage is not present, check wiring between regulator and bus.</p> <p>4. Remove plug from regulator and start engine. Momentarily jumper the "A+" and "F" terminals together on the plug. Ship's ammeter should show heavy rate of charge. If heavy charge rate is observed, replace regulator. If heavy charge rate is not observed, proceed to step 5.</p>

16-39. TROUBLE SHOOTING THE ALTERNATOR SYSTEM (Cont).

TROUBLE	PROBABLE CAUSE	REMEDY
ALTERNATOR SYSTEM WILL NOT KEEP BATTERY CHARGED (Cont).	Faulty wiring between alternator and regulator, or faulty alternator (Cont).	5. Check resistance from "F" terminal of regulator to "F" terminal of alternator. Normal indication is a very low resistance. If reading indicates no, or poor continuity, repair or replace wiring from regulator to alternator.
		6. Check resistance from "F" terminal of alternator to alternator case. Normal indication is 6-7 ohms. If resistance is high or low, repair or replace alternator.
		7. Check resistance from case of alternator to airframe ground. Normal indication is very low resistance. If reading indicates no, or poor continuity, repair or replace alternator ground wiring.
ALTERNATOR OVERCHARGES BATTERY - BATTERY USES EXCESSIVE WATER.	Regulator faulty or improperly adjusted.	Check bus voltage with engine running. Normal indication agrees with voltage vs temperature chart on page 16-13. Observe ship's ammeter, ammeter should indicate near zero after a few minutes of engine operation. Replace regulator.
OVER-VOLTAGE WARNING LIGHT ON.	Regulator faulty or improperly adjusted. Faulty sensor switch.	1. With engine running turn off and on battery portion of the master switch. If the light stays on shut down engine then turn on the "BAT and "ALT" portions of the master switch. Check for voltage at the "S" terminal of the voltage regulator. If voltage is present adjust or replace regulator. If voltage is not present check master switch and wiring for short or open condition. If wiring and switch are normal replace sensor.

16-40. REMOVAL AND INSTALLATION. (GEAR DRIVEN ALTERNATOR). (Refer to figure 16-3.)

- a. Ensure that the master switch is off and the negative lead is disconnected from the battery.
- b. Remove wiring from the alternator and label.
- c. Remove screw and nut holding blast tube to support strap clamp, blast tube will then be free for removal.
- d. Remove nuts and washers from alternator mounting bolts.
- e. Remove alternator.
- f. To replace alternator, reverse this procedure.

16-41. REMOVAL AND INSTALLATION. (BELT DRIVEN ALTERNATOR). (Refer to figure 16-4.)

- a. Ensure that the master switch is off and the negative lead is disconnected from the battery.
- b. Remove wiring from the alternator and label.
- c. Remove safety wire from the upper adjusting bolt and loosen bolt.
- d. Remove safety wire from lower adjusting bolt and remove bolt.
- e. Remove the locknut from the alternator mounting bolt.
- f. Remove the alternator drive belt and the alter-

nator mounting bolt, the alternator will then be free for removal.

g. To replace the alternator, reverse this procedure.

h. Apply a torque wrench to the nut on alternator pulley and adjust the belt tension so the belt slips when the following torque value is applied.

TORQUE VALUES FOR CHECKING ALTERNATOR BELT TENSION	
Used Belt	New Belt
Slips At 7 to 9 Ft. Lbs.	Slips At 11 to 13 Ft. Lbs.
— NOTE —	
Whenever a new belt is installed, belt tension should be checked within 10 to 25 hours of operation.	

i. Tighten and safety wire upper and lower adjusting bolts.

j. Tighten alternator mounting bolt.

16-42. ALTERNATOR FIELD CIRCUIT PROTECTION. On all 172 models except the F172, a automatic resetting circuit breaker located on the back of the instrument panel is provided to protect the alternator field circuit.

16-43. OVER-VOLTAGE WARNING SYSTEM.

16-44. DESCRIPTION. The over-voltage system consists of an over-voltage sensor switch and a red warning light labeled "HIGH VOLTAGE". The over-voltage sensor is attached to the wire bundle behind the instrument panel and the light is located on the right hand side of the instrument panel. When an over-voltage tripoff occurs the over-voltage sensor turns off the alternator system and the red warning light comes on. The ammeter will show a discharge. Turn off both sections of the master switch to recycle the over-voltage sensor. If the over-voltage condition was transient, the normal alternator charging will resume and no further action is necessary. If the over-voltage tripoff recurs, then a generating system malfunction has occurred such that the electrical accessories must be operated from the aircraft battery only. Conservation of electrical energy must be practiced until the flight can be terminated. The over-voltage light filament may be tested at any time by turning off the "Alternator" portion of the master switch and leaving the battery portion on. This test does not induce an over-voltage condition on the electrical system. On models prior to aircraft serial 17260318 and F17200826, should nuisance trip-outs occur caused by voltage spikes or transient voltage, Cessna Single-engine Service Letter SE72-15 dated April 21, 1972 should be complied with.

NOTE

The over-voltage sensor switch contains solid state devices. Observe proper polarity before supplying power. Grounding the orange lead or interconnecting orange and black leads will destroy the device. When removal is required for replacement, identify (tag) wiring and follow the wiring diagram in Section 20 for re-wiring.

16-45. ALTERNATOR VOLTAGE REGULATOR.

16-46. DESCRIPTION. The alternator voltage regulator contains two relays. One relay is actuated by the aircraft master switch and connects the regulator to the battery. The second relay is a two-stage, voltage sensitive device which is used to control the current applied to the field winding of the alternator. When the upper set of contacts on the voltage regulator relay are closed, full bus voltage is applied to the field. This condition will exist when the battery is being heavily charged or when a very heavy load is applied to the system. When the upper contacts open, as the voltage begins to rise toward normal bus voltage, the voltage to the alternator field is reduced through a resistor network in the base of the regulator, thus reducing the output from the alternator. As the voltage continues to rise, assuming a very light load on the system, the lower contacts will close and ground the alternator field and shut the alternator completely off. Under lightly loaded conditions the voltage relay will vibrate between the intermediate charge rate and the lower (completely off) contacts. Under a moderate load, the relay will vibrate between the intermediate charge rate and the upper (full output) contacts.

The voltage relay is temperature compensated so that the battery is supplied with the proper charging voltage for all operating temperatures. With the battery fully charged (ship's ammeter indicating at or near zero) and a moderate load applied to the system (a taxi light turned on) the voltage at the bus bar should be within the range shown according to the air temperature on the following chart:

TEMPERATURE	BUS VOLTAGE
60 - 74°F . . . . .	13.8 - 14.1
75 - 90°F . . . . .	13.7 - 14.0
91 - 100°F . . . . .	13.6 - 13.9
The voltage regulator is adjustable but adjustment on the airplane is not recommended. A bench adjustment procedure is outlined in the Cessna Alternator Charging Systems Service/Parts Manual.	

16-47. TROUBLE SHOOTING. For trouble shooting the voltage regulator refer to paragraph 16-39.

16-48. REMOVAL AND INSTALLATION. (Refer to figure 16-5.)

a. Make sure that the master switch is off, or dis-

- connect the negative lead from the battery.
- b. Remove the connector plug from the regulator.
  - c. Remove two screws holding the regulator on the

firewall.

- d. To replace the regulator, reverse the procedure. Be sure that the connections for grounding the alter-

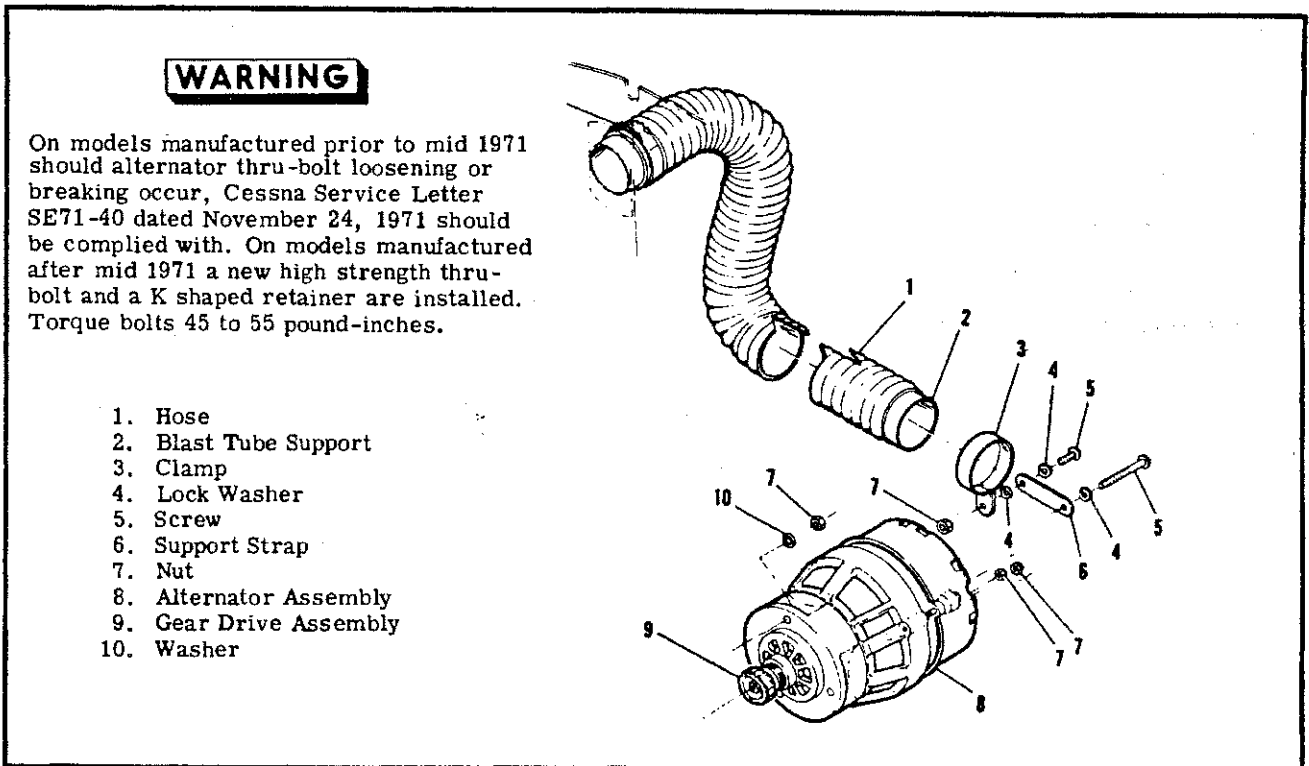

Figure 16-3. Gear-Driven Alternator Installation

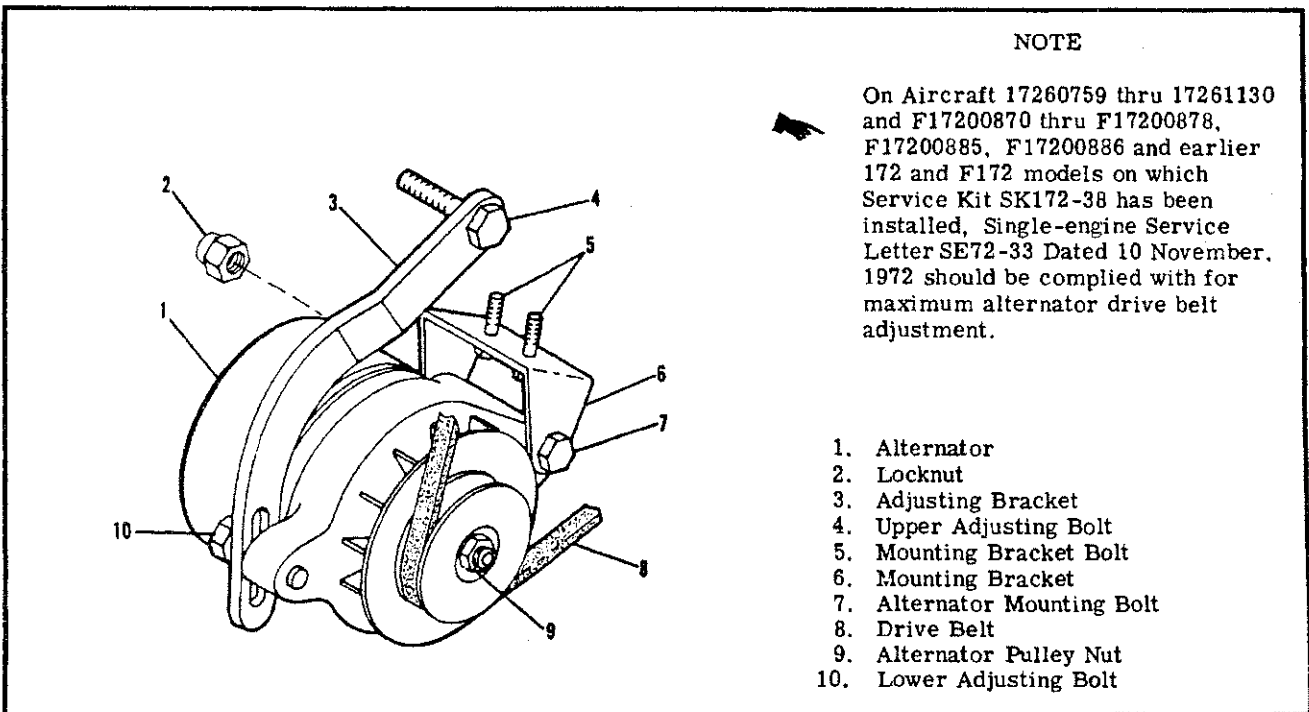
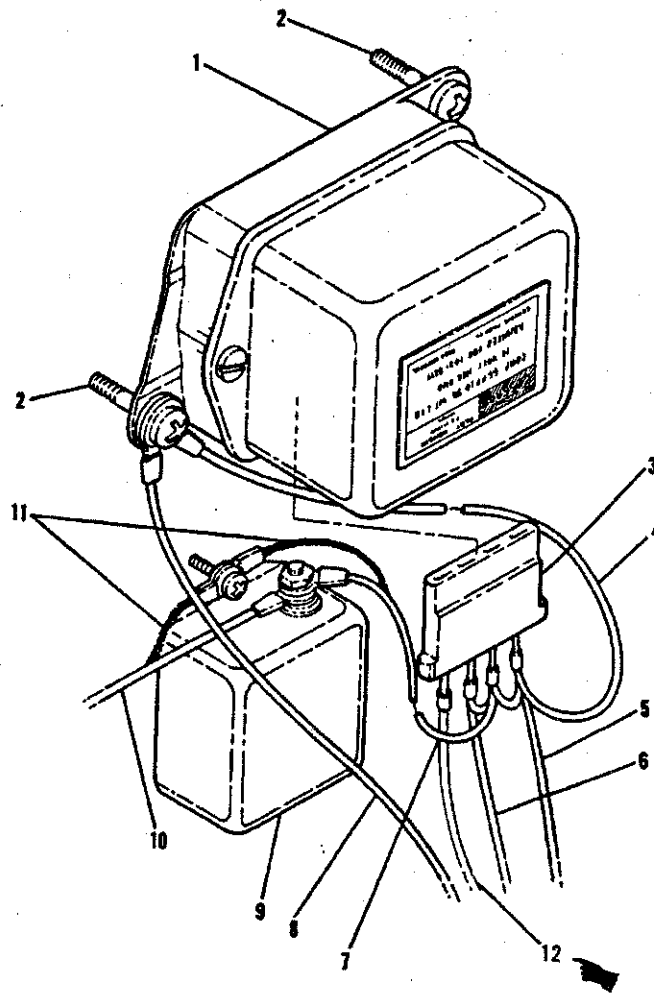

Figure 16-4. Belt-Driven Alternator Installation

nator, wiring shields and the base of the regulator are clean and bright before assembly. Otherwise,

poor voltage regulation and/or excessive radio noise may result.



- |                           |                              |                               |
|---------------------------|------------------------------|-------------------------------|
| 1. Voltage Regulator      | 5. Wire to Alternator "F"    | 9. Filter - Radio Noise       |
| 2. Screw                  | 6. Wire to Alternator "A+"   | 10. Wire to Master Switch     |
| 3. Housing                | 7. Wire to Filter            | 11. Shield - Ground           |
| 4. Wire Shields to Ground | 8. Wire to Alternator Ground | 12. Wire to Overvoltage Light |

Figure 16-5. Voltage Regulator Installation



16-49. AIRCRAFT LIGHTING SYSTEM.

16-50. DESCRIPTION. The aircraft lighting system consists of landing and taxi lights, navigation lights,

anti-collision strobe lights, flashing beacon light, dome, instrument flood lights and courtesy light, map light, control wheel map light, compass and radio dial lights.

16-51. TROUBLE SHOOTING.

TROUBLE	PROBABLE CAUSE	REMEDY
LANDING AND TAXI LIGHT(S) OUT.	Short circuit in wiring.	1. Inspect circuit breaker. If circuit breaker is open, proceed to step 2. If circuit breaker is O.K. proceed to step 3.
	Defective wiring.	2. Test each circuit separately until short is located. Repair or replace wiring.
	Defective switch.	3. Check voltage at lights with master and landing and taxi light switches ON. Should read battery voltage. Replace switch.
LANDING AND/OR TAXI LIGHT OUT.	Lamp burned out.	1. Test lamp with ohmmeter or new lamp. Replace lamp.
	Open circuit in wiring.	2. Test wiring for continuity. Repair or replace wiring.
FLASHING BEACON DOES NOT LIGHT.	Short circuit in wiring.	1. Inspect circuit breaker. If circuit breaker is open, proceed to step 2. If circuit breaker is O.K. proceed to step 3.
	Defective wiring.	2. Test circuit until short is located. Repair or replace wiring.
	Lamp burned out.	3. Test lamp with ohmmeter or a new lamp. Replace lamp. If lamp is good, proceed to step 4.
	Open circuit in wiring.	4. Test circuit from lamp to flasher for continuity. If no continuity is present, repair or replace wiring. If continuity is present, proceed to step 5.
	Defective switch.	5. Check voltage at flasher with master and beacon switch on. Should read battery voltage. Replace switch. If voltage is present, proceed to step 6.
	Defective flasher.	6. Install new flasher.
FLASHING BEACON CONSTANTLY LIT.	Defective flasher.	1. Install new flasher.
ALL NAV LIGHTS OUT.	Short circuit in wiring.	1. Inspect circuit breaker. If circuit breaker is open, proceed to step 2. If circuit breaker is O.K. proceed to step 3.

16-51. TROUBLE SHOOTING (Cont).

TROUBLE	PROBABLE CAUSE	REMEDY
ALL NAV LIGHTS OUT. (Cont).	Defective wiring.	2. Isolate and test each nav light circuit until short is located. Repair or replace wiring.
	Defective switch.	3. Check voltage at nav light with master and nav light switches on. Should read battery voltage. Replace switch.
ONE NAV LIGHT OUT.	Lamp burned out.	1. Inspect lamp. Replace lamp.
	Open circuit in wiring.	2. Test wiring for continuity. Repair or replace wiring.
ONE ANTI-COLLISION STROBE LIGHT DOES NOT LIGHT. THRU 1972 MODELS.	Flash tube burned out.	Test with new flash tube. Replace flash tube.
	Faulty wiring.	Test for continuity. Repair or replace.
	Faulty trigger head.	Test with new trigger head. Replace trigger head.
BOTH ANTI-COLLISION STROBE LIGHTS WILL NOT LIGHT. THRU 1972 MODELS.	Circuit breaker open.	Inspect. Reset.
	Faulty power supply.	Listen for whine in power supply to determine if power is operating.
	Faulty switch.	Test for continuity. Repair or replace.
	Faulty wiring.	Test for continuity. Repair or replace.
ONE ANTI-COLLISION STROBE LIGHT WILL NOT LIGHT. BEGINNING WITH 1973 MODELS.	Flash tube burned out.	Test with new tube. Replace flash tube.
	Faulty power supply.	Listen for whine in power supply to determine if power is operating.
	Faulty wiring.	Test for continuity. Repair or replace.
	Faulty trigger head.	Test with new trigger head. Replace trigger head.
BOTH ANTI-COLLISION STROBE LIGHTS WILL NOT LIGHT. BEGINNING WITH 1973 MODELS.	Circuit breaker open.	Inspect. Reset.
	Faulty switch.	Test for continuity. Repair or replace.
	Faulty wiring.	Test for continuity. Repair or replace.
DOME LIGHT TROUBLE.	Short circuit in wiring.	1. Inspect circuit breaker. If circuit breaker is open, proceed to step 2. If circuit breaker is O.K. proceed to step 3.
	Defective wiring.	2. Test circuit until short is located. Repair or replace wiring.

16-51. TROUBLE SHOOTING (Cont).

TROUBLE	PROBABLE CAUSE	REMEDY
DOME LIGHT TROUBLE (Cont).	Defective wiring (Cont).	3. Test for open circuit. Repair or replace wiring. If no short or open circuit is found, proceed to step 4.
	Lamp burned out.	4. Test lamp with ohmmeter or new lamp. Replace lamp.
	Defective switch.	5. Check for voltage at dome light with master and dome light switch on. Should read battery voltage. Replace switch.
INSTRUMENT LIGHTS WILL NOT LIGHT. (THRU 1970 MODELS).	Short circuit in wiring.	1. Inspect circuit breaker. If circuit breaker is open, proceed to step 2. If circuit breaker is O.K. proceed to step 3.
	Defective wiring.	2. Test circuit until short is located. Repair or replace wiring. 3. Test for open circuit. Repair or replace wiring. If no short or open circuit is found, proceed to step 4.
	Defective rheostat.	4. Check voltage at instrument light with master switch on. Should read battery voltage with rheostat turned full clockwise and voltage should decrease as rheostat is turned counterclockwise. If no voltage is present or voltage has a sudden drop before rheostat has been turned full counterclockwise, replace rheostat.
	Lamp burned out.	5. Test lamp with ohmmeter or new lamp. Replace lamp.
INSTRUMENT LIGHTS WILL NOT LIGHT (1971 MODELS & ON).	Short circuit wiring.	1. Inspect circuit breaker. If circuit breaker is open, proceed to step 2. If circuit breaker is OK, proceed to step 3.
	Defective wiring.	2. Test circuit until short is located. Repair or replace wiring.
		3. Test for open circuit. Repair or replace wiring. If no short or open circuit is found, proceed to step 4.
	Faulty section in dimming potentiometer.	4. Lights will work when control is placed in brighter position. Replace potentiometer.

16-51. TROUBLE SHOOTING (Cont).

TROUBLE	PROBABLE CAUSE	REMEDY
INSTRUMENT LIGHTS WILL NOT LIGHT (1971 MODELS & ON). (Cont).	Faulty light dimming transistor.	5. Test both transistors with new transistor. Replace faulty transistor.
	Faulty selector switch.	6. Inspect. Replace switch.
INSTRUMENT LIGHTS WILL NOT DIM (1971 MODELS & ON).	Open resistor or wiring in minimum intensity end of potentiometer.	1. Test for continuity. Replace resistor or repair wiring.
	Shorted transistor.	2. Test transistor by substitution. Replace defective transistor.
CONTROL WHEEL MAP LIGHT WILL NOT LIGHT THRU 1970 AIRCRAFT ONLY.	Nav light switch turned off.	1. Nav light switch has to be ON before map light will light.
	Short circuit in wiring.	2. Check lamp fuse on terminal board located on back of stationary panel with ohmmeter. If fuse is open, proceed to step 3. If fuse is OK, proceed to step 4.
	Defective wiring.	3. Test circuit until short is located. Repair or replace wiring. 4. Test for open circuit. Repair or replace wiring. If a short or open circuit is not found, proceed to step 5.
CONTROL WHEEL MAP LIGHT WILL NOT LIGHT THRU 1970 AIRCRAFT ONLY (Cont).	Defective map light assembly.	5. Check voltage at map light assembly with master and nav switches on. If battery voltage is present, replace map light assembly.
<p><b>CAUTION</b></p> <p>Failure to observe polarity shown on wiring diagrams 11.7.0, will result in immediate failure of the transistor on the map light circuit board assembly.</p>		
CONTROL WHEEL MAP LIGHT WILL NOT LIGHT 1971 AIRCRAFT & ON.	Nav light switch turned off.	1. Nav light switch has to be ON before map light will light.
	Short circuit in wiring.	2. Check lamp fuse on terminal board located on back of stationary panel with ohmmeter. If fuse is open, proceed to step 3. If fuse is OK, proceed to step 4.

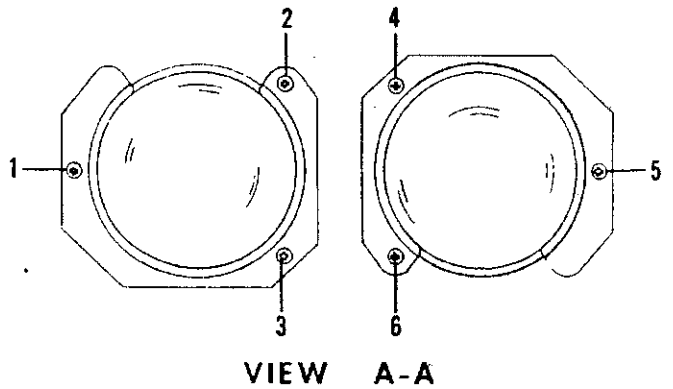
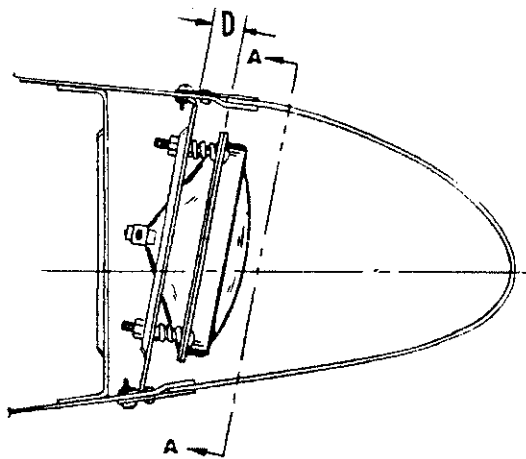

D I M E N S I O N D

NO.	172 & F172
1	0.60
2	0.70
3	0.90
4	0.50
5	1.08
6	0.85

THRU AIRCRAFT SERIALS  
17259223 AND F17200754

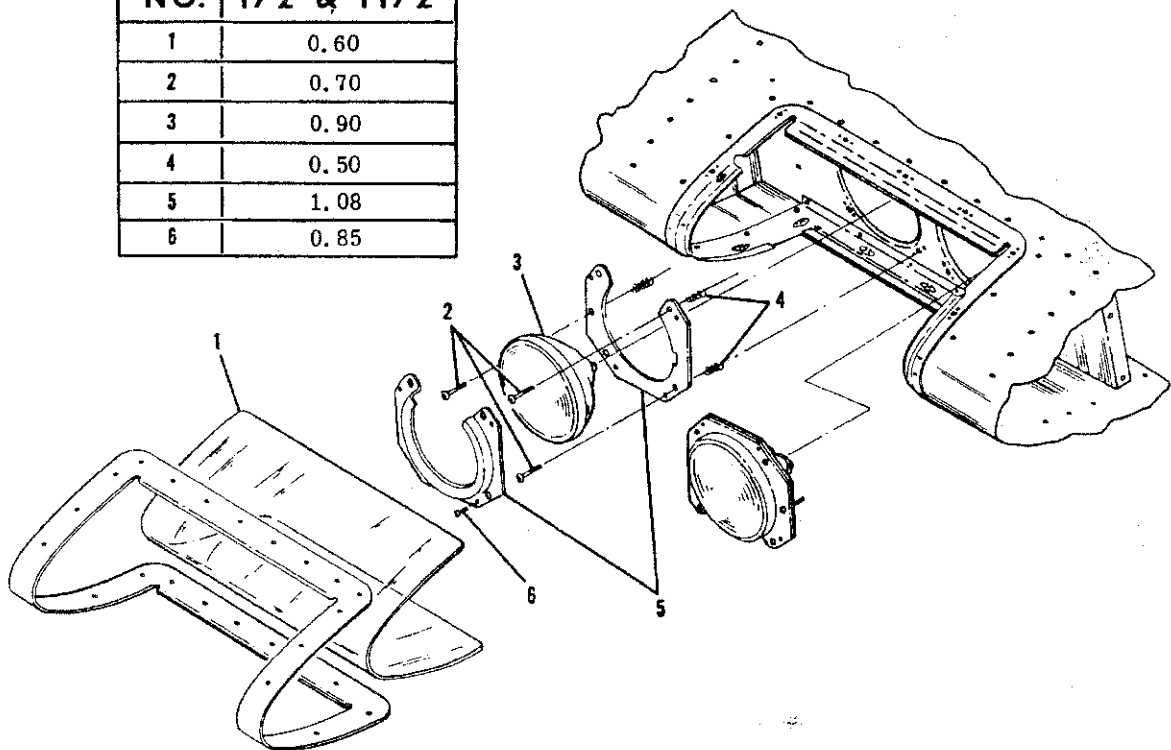

1. Window

2. Adjusting Screw

3. Lamp

4. Spring

5. Bracket

6. Screw

Figure 16-6. Landing and Taxi Light Installation (Wing) (Sheet 1 of 4)

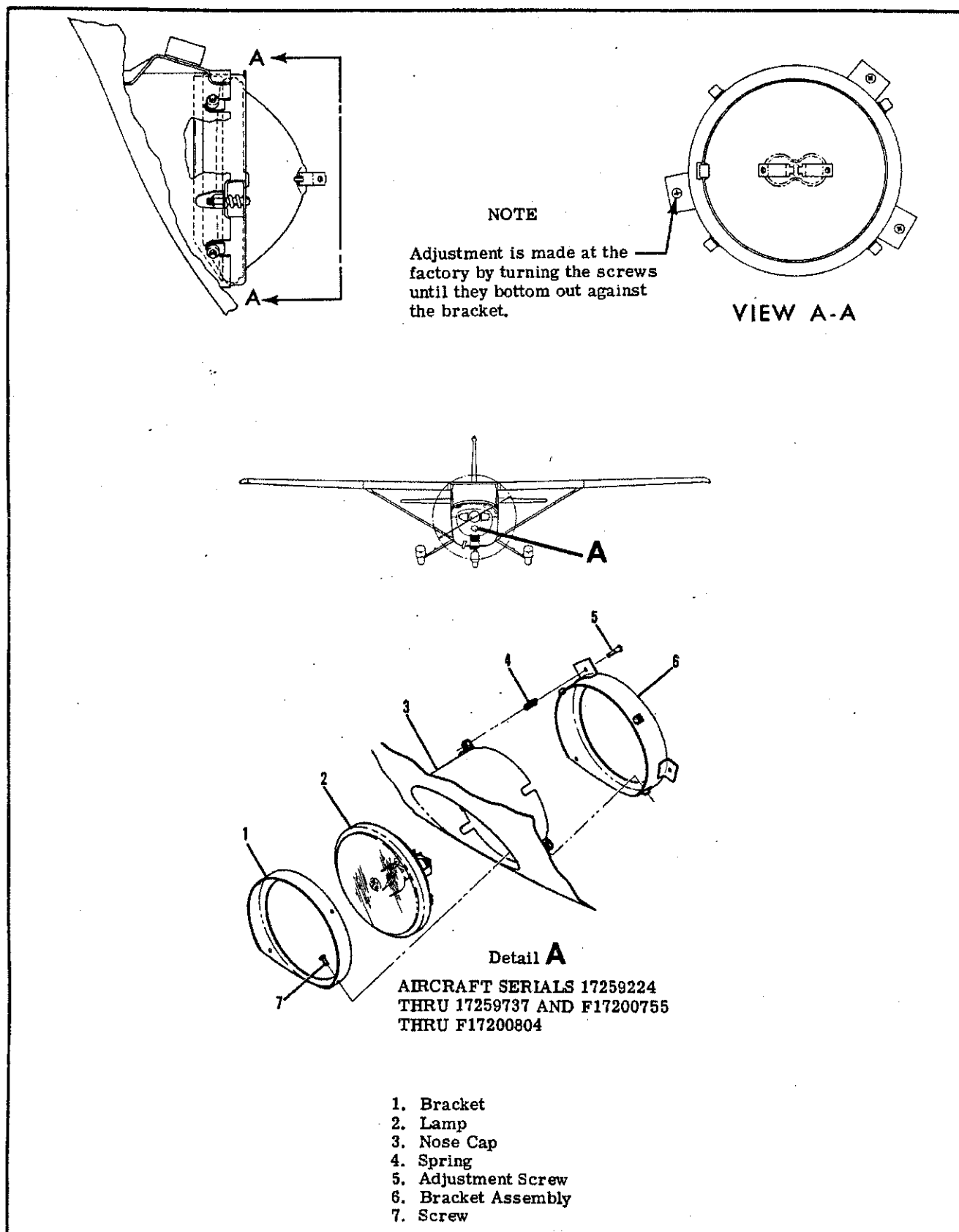
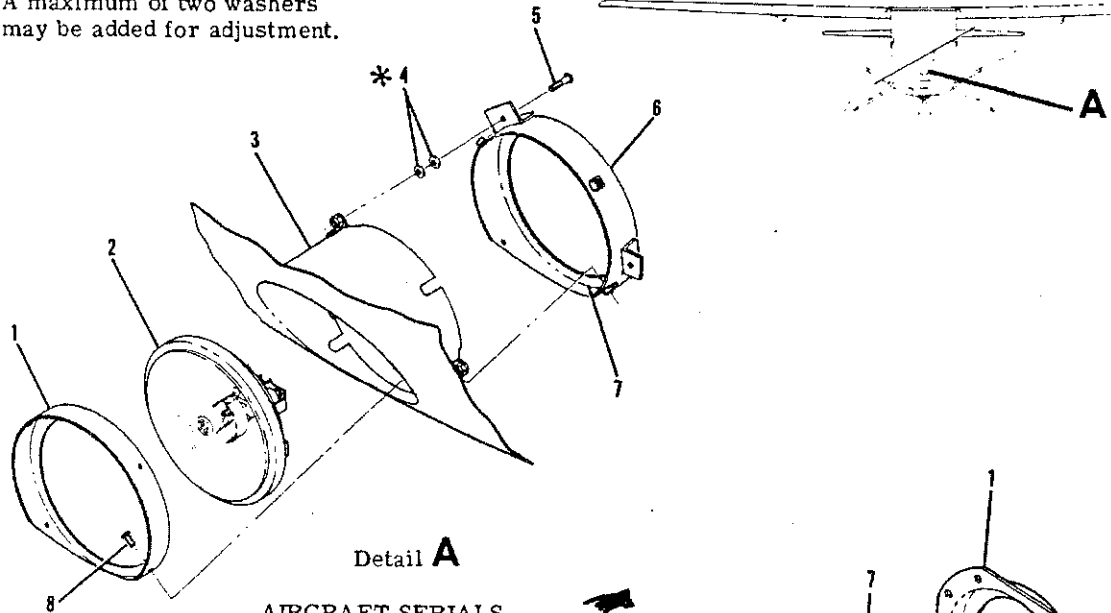

Figure 16-6. Landing and Taxi Light Installation (Cowl) (Sheet 2 of 4)

NOTE

\* A maximum of two washers may be added for adjustment.



AIRCRAFT SERIALS  
17259738 THRU 17260758  
AND F17200805 THRU  
F17200881 AND ALL SPARES

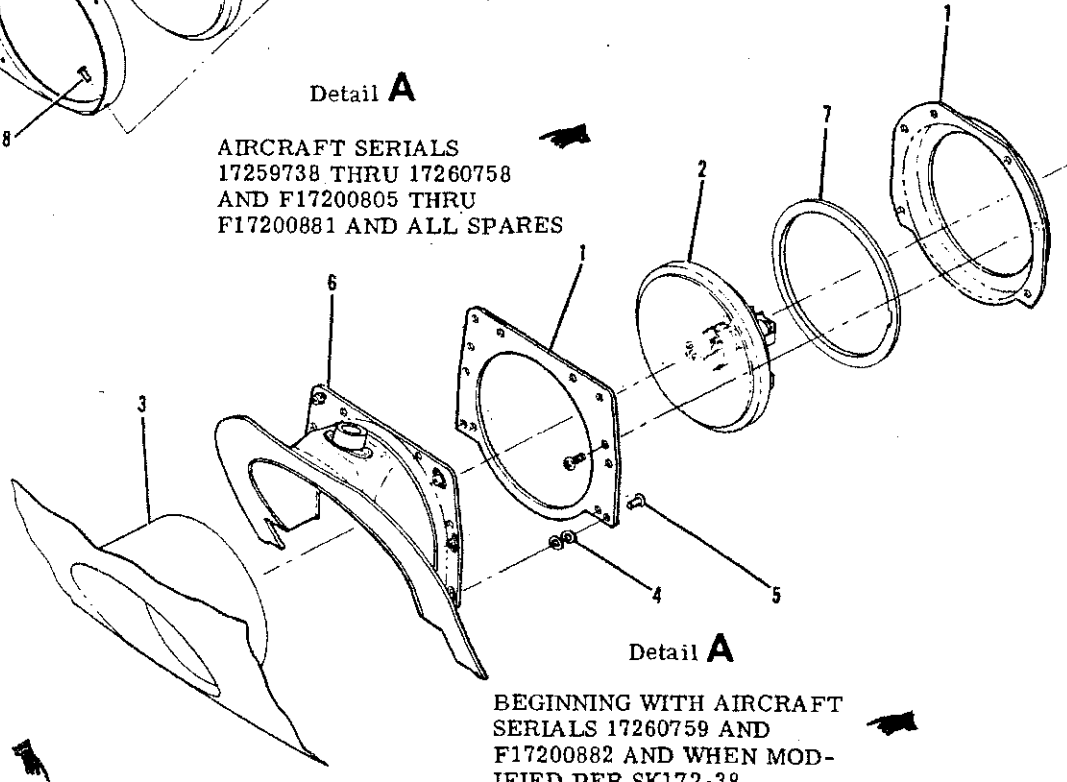

BEGINNING WITH AIRCRAFT  
SERIALS 17260759 AND  
F17200882 AND WHEN MOD-  
IFIED PER SK172-38.

NOTE

On Aircraft 17260759 thru 17261130 and F17200870 thru F17200878, F17200885, F17200886 and earlier 172 and F172 models on which Service Kit SK172-38 has been installed, Single-engine Service Letter SE72-33, Dated 10 November, 1972 should be complied with for maximum alternator drive belt adjustment.

1. Bracket
2. Lamp
3. Landing Light Support
4. Washer
5. Adjustment Screw
6. Bracket Assembly
7. Gasket
8. Screw

Figure 16-6. Landing and Taxi Light Installation (Cowl) (Sheet 3 of 4)

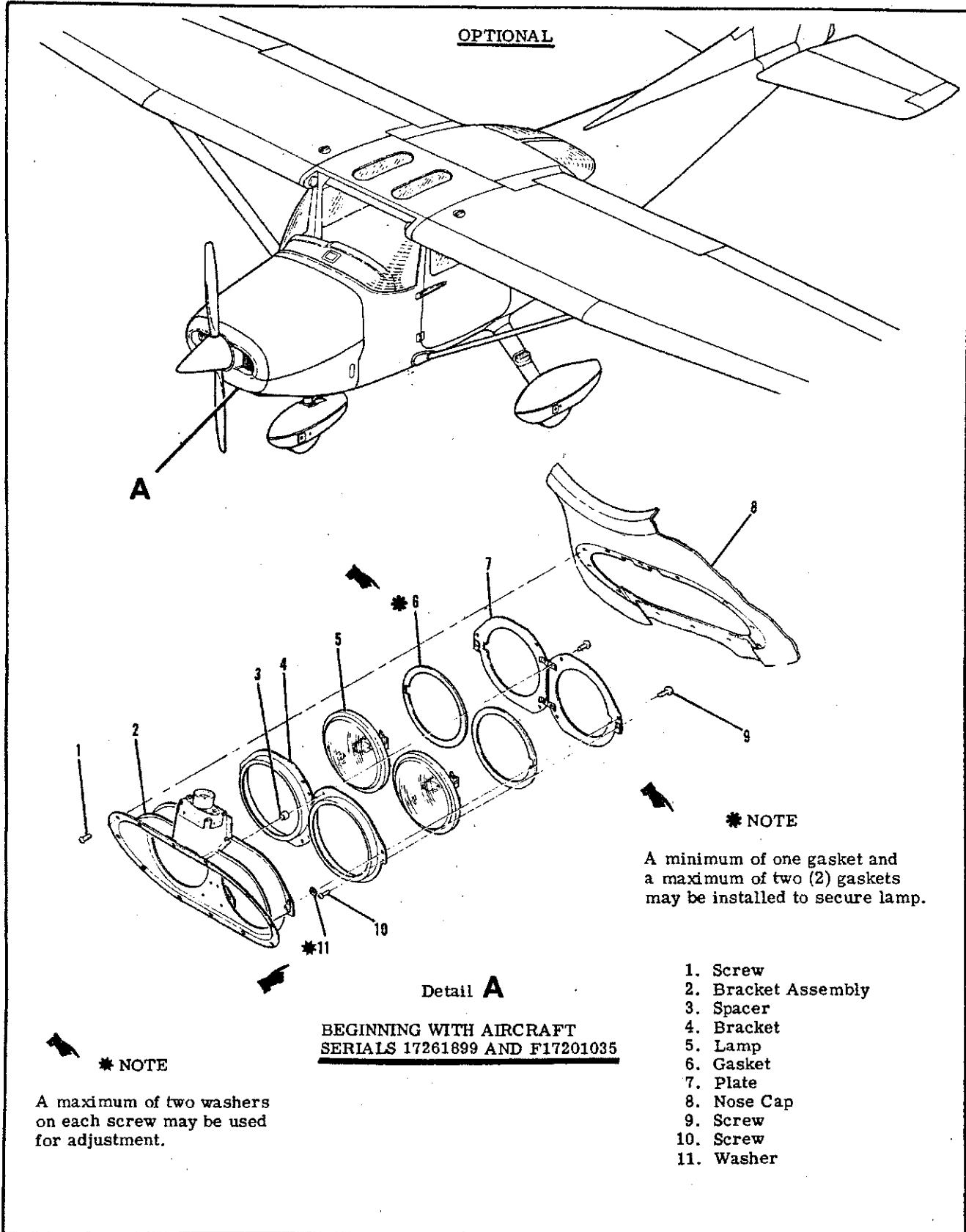

Figure 16-6. Landing and Taxi Light Installation (Cowl) (Sheet 4 of 4)



16-51. TROUBLE SHOOTING (Cont).

TROUBLE	PROBABLE CAUSE	REMEDY
CONTROL WHEEL MAP LIGHT WILL NOT LIGHT 1971 AIRCRAFT & ON. (Cont.)	Defective wiring.	3. Test circuit until short is located. Repair or replace wiring.  4. Test for open circuit. Repair or replace wiring. If a short or open circuit is not found, proceed to step 5.
	Defective map light assembly.	5. Check voltage at map light assembly with master and nav switches on. If battery voltage is present, replace map light assembly.

16-52. LANDING AND TAXI LIGHTS (WING MOUNTED).

16-53. DESCRIPTION. The landing and taxi lights are mounted in the leading edge of the left wing. A clear plastic cover provides weather protection for the lamps and is shaped to maintain the leading edge curvature of the wing. The landing light lamp is mounted on the inboard side and adjusted to throw its beam further forward than the taxi light. The landing and taxi lights are both controlled by a single pull type switch located on the instrument panel.

16-54. REMOVAL AND INSTALLATION OF LANDING AND TAXI LIGHTS (WING MOUNTED).

- a. Remove the 18 screws securing the landing light window assembly (1) and the assembly will then be free for removal.
- b. Remove the four attaching screws (6) from the bracket assembly and remove the bracket.

NOTE

Do not reposition the landing and taxi light adjustment screws (2). If readjustment is required refer to figure 16-6.

- c. Remove the two screws securing the wiring to the lamp contacts and remove the lamp.
- d. Install new lamp and reassemble.

16-55. LANDING AND TAXI LIGHT (COWL MOUNTED).

16-56. DESCRIPTION. The landing and taxi light is mounted in the forward end of the engine cowling. This position facilitates the use of one lamp as both a landing and taxi light. The landing and taxi light is controlled by a rocker type switch on the instrument panel.

16-57. REMOVAL AND INSTALLATION. (COWL MOUNTED) (THRU AIRCRAFT SERIALS 17260758 AND F17200881 EXCEPT WHEN MODIFIED IN ACCORDANCE WITH SK172-38) (Refer to figure 16-6.)

- a. Remove the 4 screws securing bracket (1) to nose cap (3) and remove the bracket.
- b. Pull the lamp away from the nose cap until the wire connections are exposed on the base of the lamp. Disconnect the wires and remove the lamp.
- c. To reinstall the lamp reverse this procedure.

16-58. REMOVAL AND INSTALLATION. (COWL MOUNTED) (BEGINNING WITH AIRCRAFT SERIALS 17260759 and F1700882 AND WHEN MODIFIED IN ACCORDANCE WITH SK172-38) (Refer to figure 16-6.)

- a. Disconnect lamp wires then remove lower cowl.
- b. Remove screws (5) and remove lamp assembly.

NOTE

Note position and number of washers between support (6) and bracket (1).

- c. Remove screws (8) and remove lamp.
- d. To reinstall the lamp reverse this procedure.

16-59. ADJUSTMENT OF LANDING AND TAXI LIGHT (COWL MOUNTED) (AIRCRAFT SERIALS 17259224 THRU 17259737 AND F17200755 THRU F17200804 WHEN NOT MODIFIED IN ACCORDANCE WITH SK172-38) (Refer to figure 16-6.) Adjustment of the landing and taxi light is preset at the factory, however changes to this adjustment may be made as desired.

- a. Remove the lamp (See paragraph 16-57.)
- b. Adjustment is accomplished by turning the screws until they bottom out against the bracket.

## NOTE

A screwdriver may be inserted through the lamp opening for screw adjustments.

Adjustments may also be made if the cowling is removed from the aircraft.

- a. Remove the cowl. (As outlined in Section 11).

## CAUTION

When removing the cowling, ensure the landing and taxi wiring connection is disconnected before removing the bottom cowling. The connector is positioned at the aft end of the cowling on the lower right side.

- b. Make screw adjustments as desired or if factory adjustment is desired the screws should be turned until they bottom out against the bracket.

16-60. ADJUSTMENT OF LANDING AND TAXI LIGHT (COWL MOUNTED) (BEGINNING WITH AIRCRAFT SERIALS 17259738 AND F17200805 AND WHEN MODIFIED IN ACCORDANCE WITH SK172-38) (Refer to figure 16-6.) Adjustment of the landing and taxi light is pre-set at the factory, however changes to this adjustment may be made as desired by adding or subtracting from the number of washers (4). A maximum of two washers may be used.

16-60A. LANDING AND TAXI LIGHTS (DUAL, COWL MOUNTED, OPTIONAL).

16-60B. DESCRIPTION. Optional, dual, cowl mounted landing and taxi lights may be installed. The left hand light is used for taxi and the right hand for landing. Two rocker type switches on the pilots switch panel control the lights. A 20 amp circuit breaker is installed to protect the system.

16-60C. REMOVAL AND INSTALLATION. (Refer to figure 16-6.)

- a. Remove screws (1) and pull bracket assembly (2) from nose cap to gain access to electrical leads.
- b. Disconnect electrical leads from lamps making sure switches are off and leads do not short out.
- c. Remove screws (9) from plate (7) and remove lamp assembly from bracket (2). If left hand (taxi) light is being removed, note position of spacers (3) and (11) for reinstallation.
- d. Remove screws (10) from bracket (4) to disassemble lamp assembly.
- e. Install new lamp and reassemble.

16-61. NAVIGATION LIGHTS.

16-62. DESCRIPTION. The navigation lights are located on each wing tip and the top edge of the vertical fin. The lights are controlled by a pull type switch located on the instrument panel.

16-63. REMOVAL AND INSTALLATION. For removal and installation of navigation lights refer to figure 16-7.

16-64. ANTI-COLLISION STROBE LIGHTS.

16-65. DESCRIPTION. A white strobe light is installed on each wing tip and lights are vibration resistant and operate on the principle of a capacitor discharge into a xenon tube, producing an extremely high intensity flash. Energy is supplied to the strobe lights from a power supply, mounted just aft of the baggage curtain, on the left side of the aircraft above the battery box thru 1972 Models, and one on each wing tip rib beginning with 1973 Models.

16-66. REMOVAL AND INSTALLATION. Use figure 16-7 as a guide for removal and installations of the anti-collision strobe light components.

## WARNING

This anti-collision system is a high voltage device. Do not remove or touch tube assembly while in operation. Wait at least 5 minutes after turning off power before starting work.

16-67. FLASHING BEACON.

16-68. DESCRIPTION. The flashing beacon light is attached to a thermoformed plastic mounting on the vertical fin. The flashing beacon is an iodine-vapor lamp electrically switched by a solid-state flasher assembly. The flasher assembly is located in the aft section of the tailcone. The switching frequency of the flasher assembly operates the beacon at approximately 45 flashes per minute.

16-69. REMOVAL AND INSTALLATION. For removal and installation of the flashing beacon refer to figure 16-8.

16-70. INSTRUMENT, DOME AND COURTESY LIGHTS.

16-71. DESCRIPTION. The instrument and dome lights are mounted in an overhead console located on the top of the cabin and provide non-glare instrument flood lighting and cabin lighting. The instrument flood light consists of a red lens and a single bulb. On models thru 1970, instrument flood lighting is controlled by a dimming rheostat mounted on the right side of the overhead console. On 1971 and on models, instrument flood lighting is controlled by a rheostat mounted on the lower, left hand portion of the instrument panel. The courtesy lights are mounted in the under side of each wing and consist of a lens and single bulb, lighting is controlled by the dome light switch.

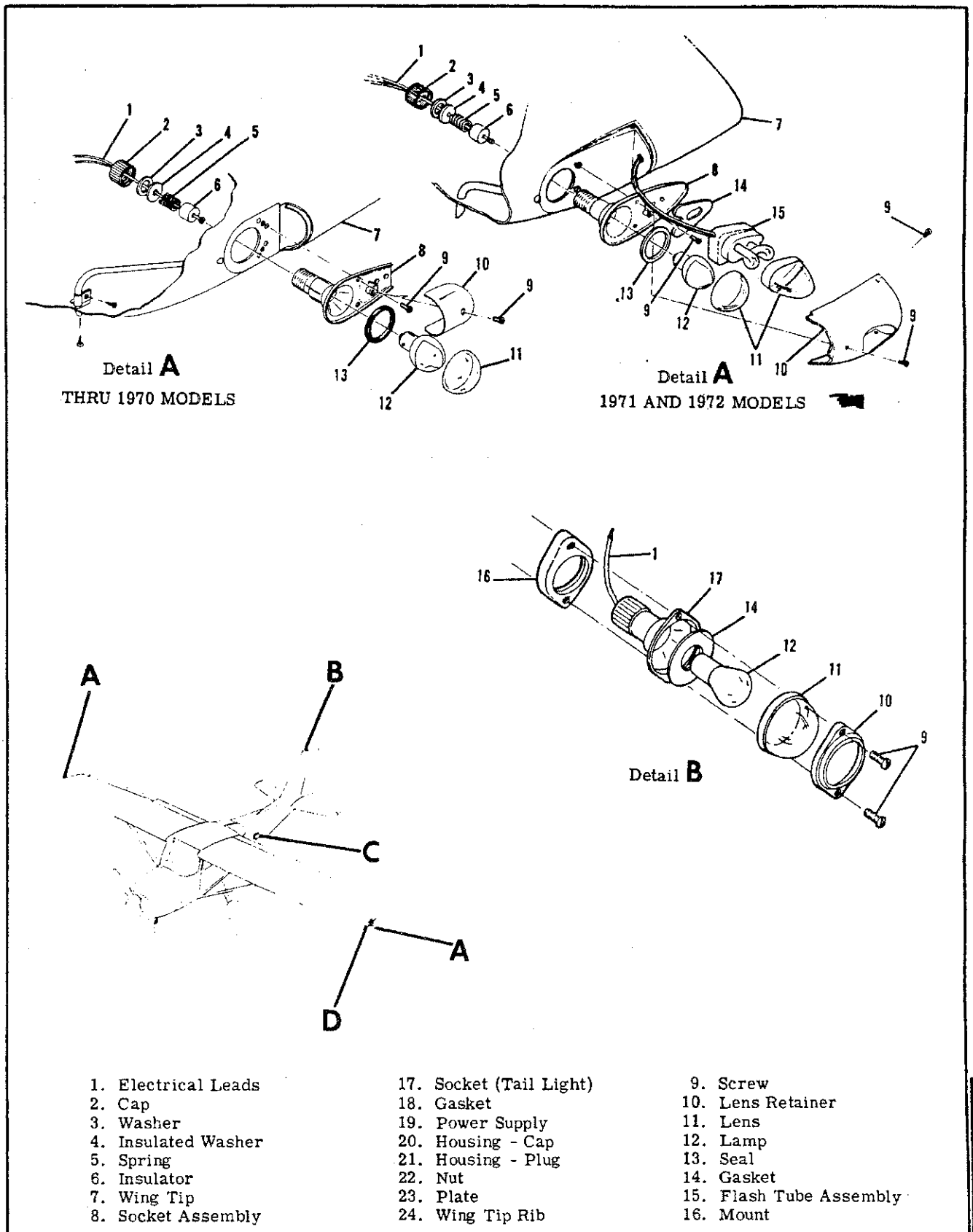
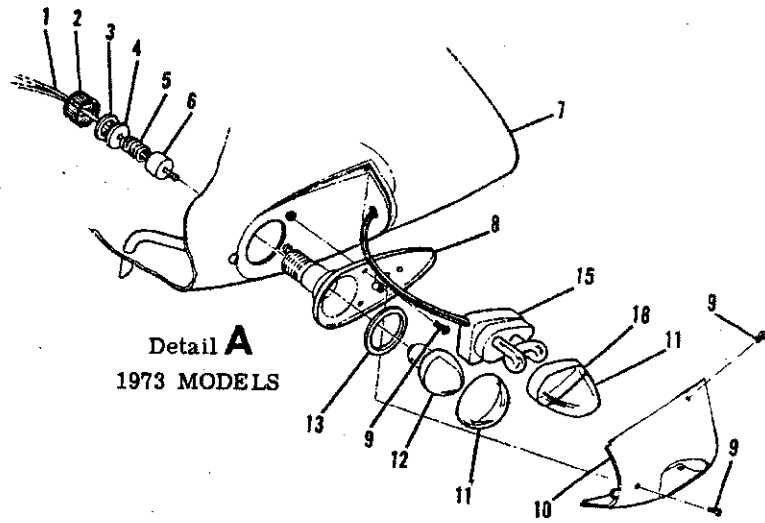
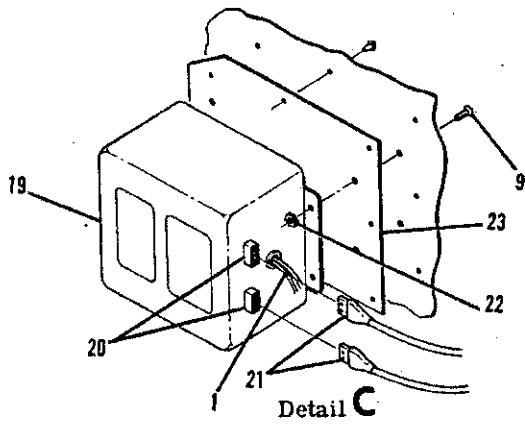

Figure 16-7. Navigation and Anti-Collision Strobe Light Installation (Sheet 1 of 2)



**Detail A**  
1973 MODELS



**Detail C**  
THRU AIRCRAFT SERIAL  
17260758 AND F17200904

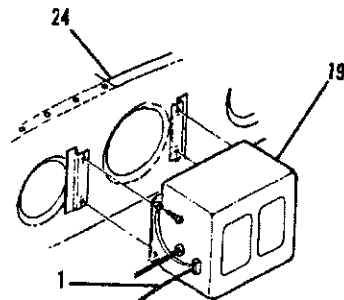

**Detail D**  
BEGINNING WITH AIRCRAFT  
SERIALS 17260759 AND F17200905

Figure 16-7. Navigation and Anti-Collision Strobe Light Installation (Sheet 2 of 2)

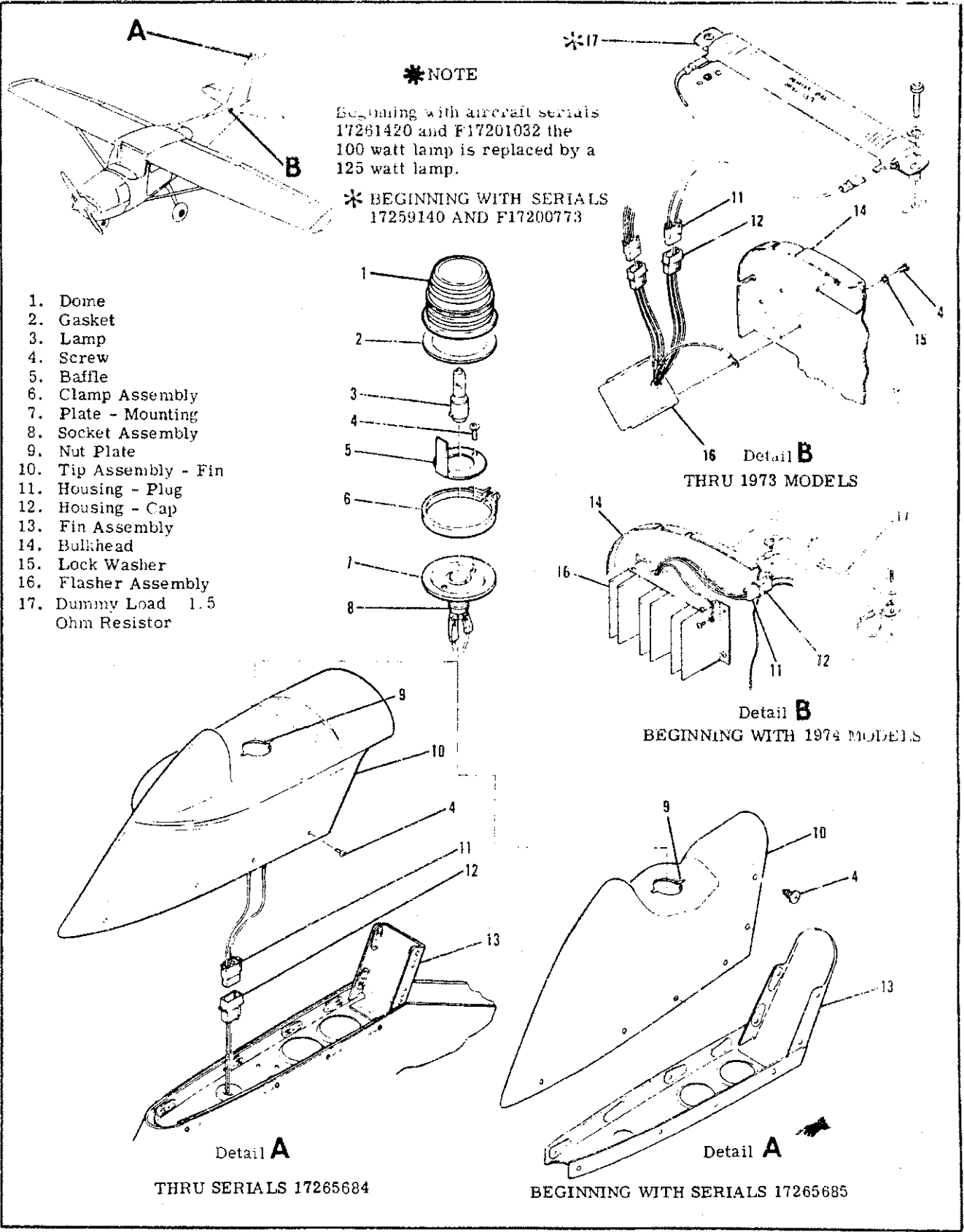

Figure 16-8. Flashing Beacon Light Installation

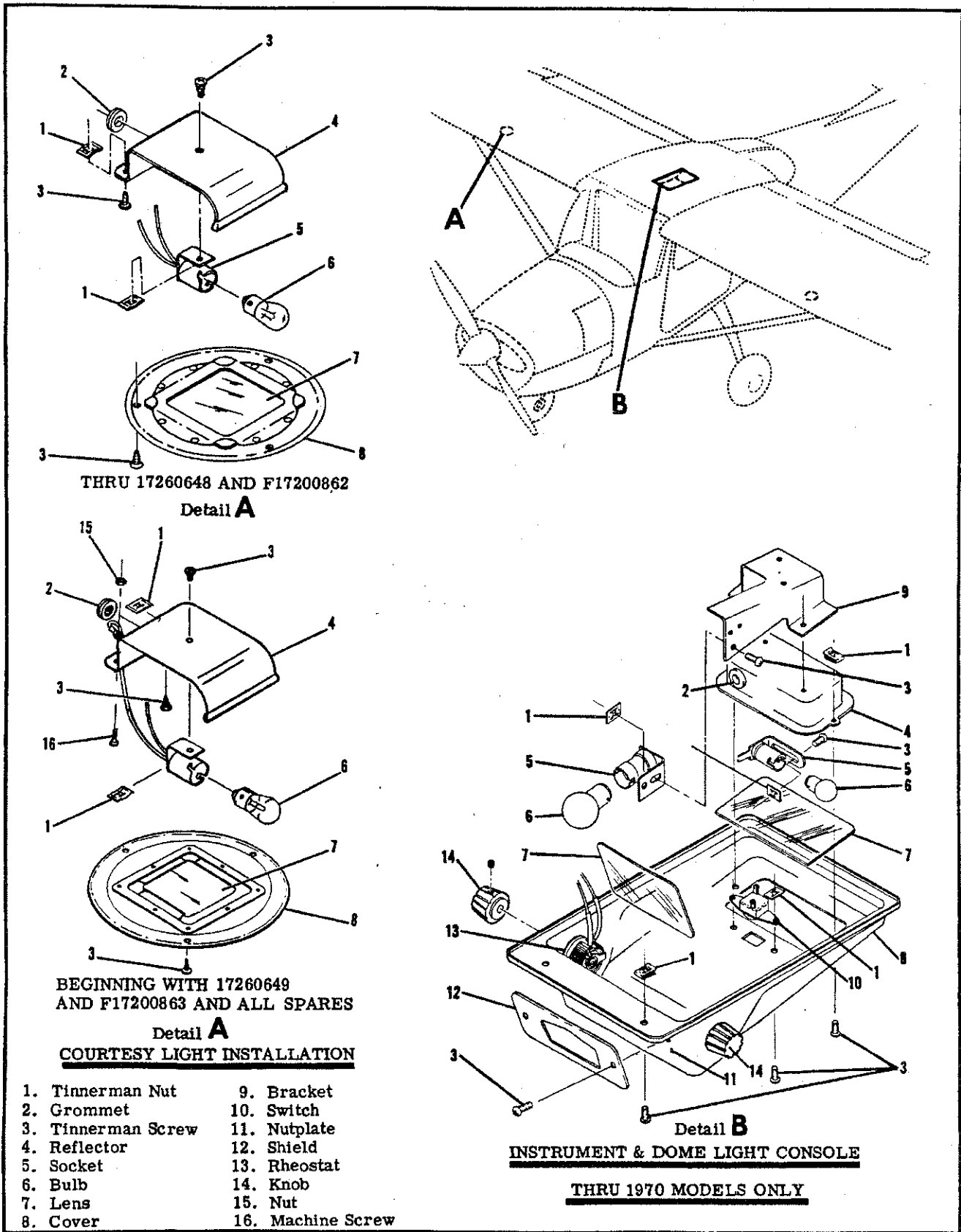

Figure 16-9. Instrument, Dome and Courtesy Light Installation (Sheet 1 of 3)

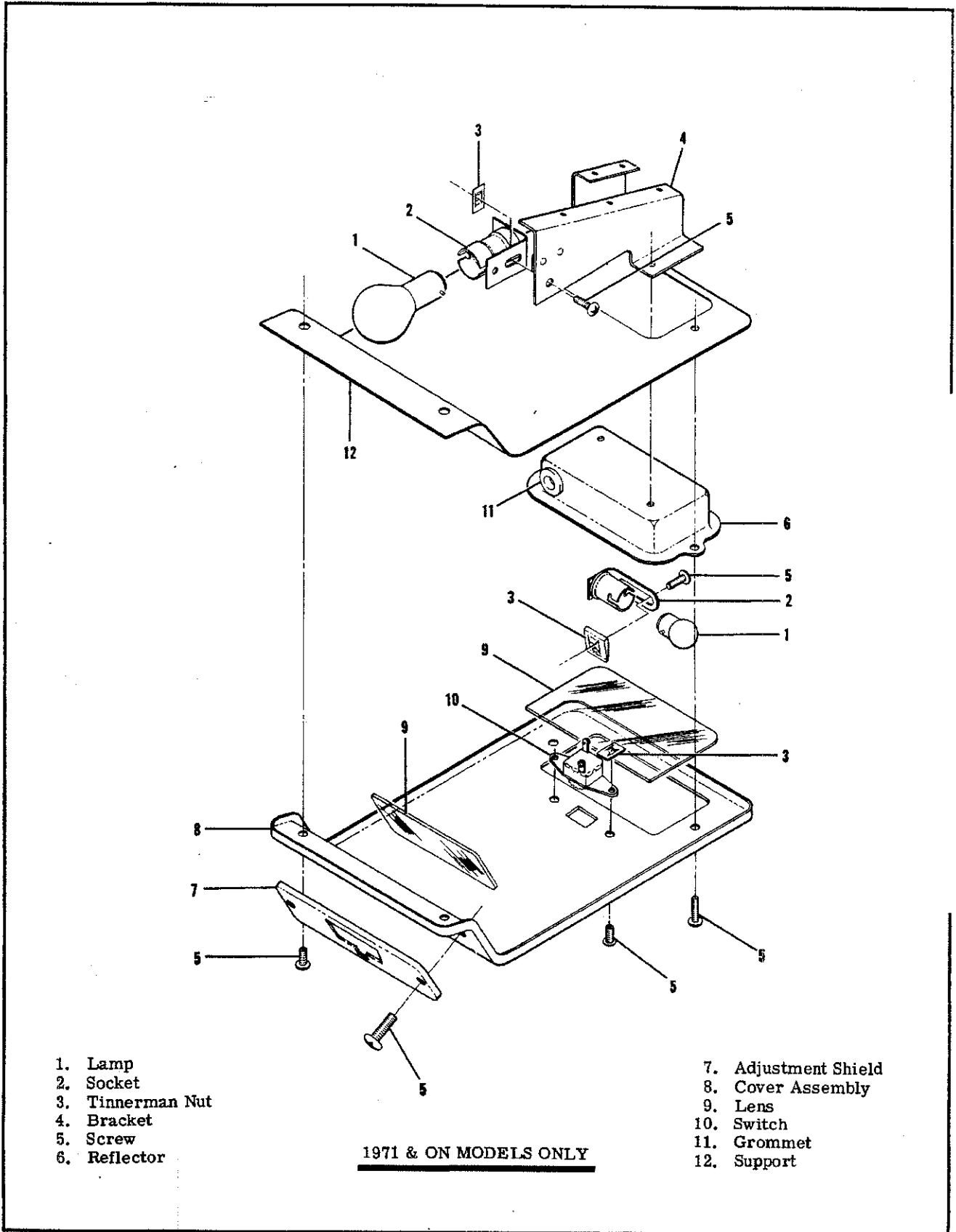
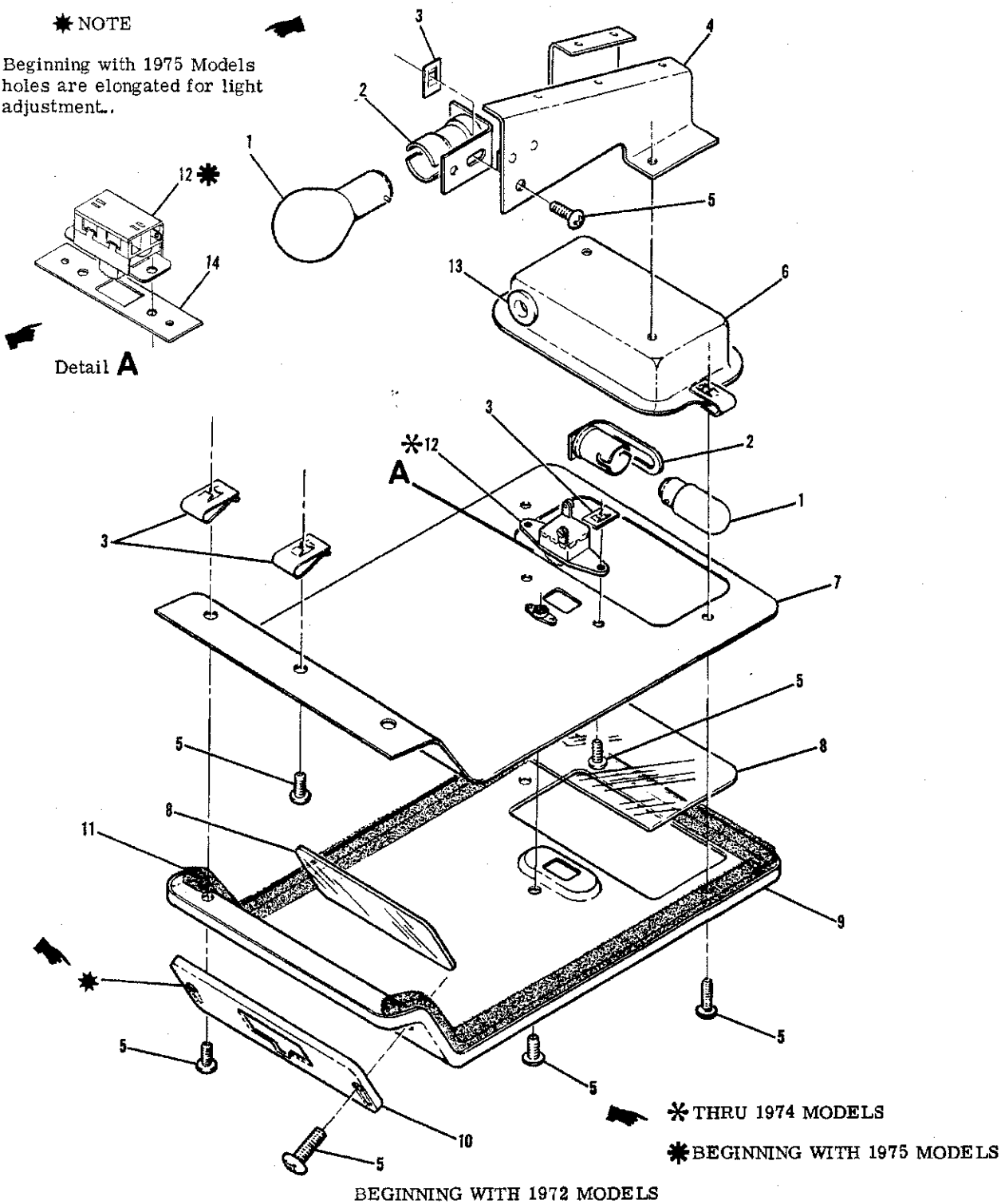

Figure 16-9. Instrument, Dome and Courtesy Light Installation (Sheet 2 of 3)

**\* NOTE**

Beginning with 1975 Models  
holes are elongated for light  
adjustment..



- |                  |                   |                       |
|------------------|-------------------|-----------------------|
| 1. Lamp          | 5. Screw          | 10. Adjustment Shield |
| 2. Socket        | 6. Reflector      | 11. Seal              |
| 3. Tinnerman Nut | 7. Support        | 12. Switch            |
| 4. Bracket       | 8. Lens           | 13. Grommet           |
|                  | 9. Cover Assembly |                       |

Figure 16-9. Instrument, Dome and Courtesy Light Installation (Sheet 3 of 3)



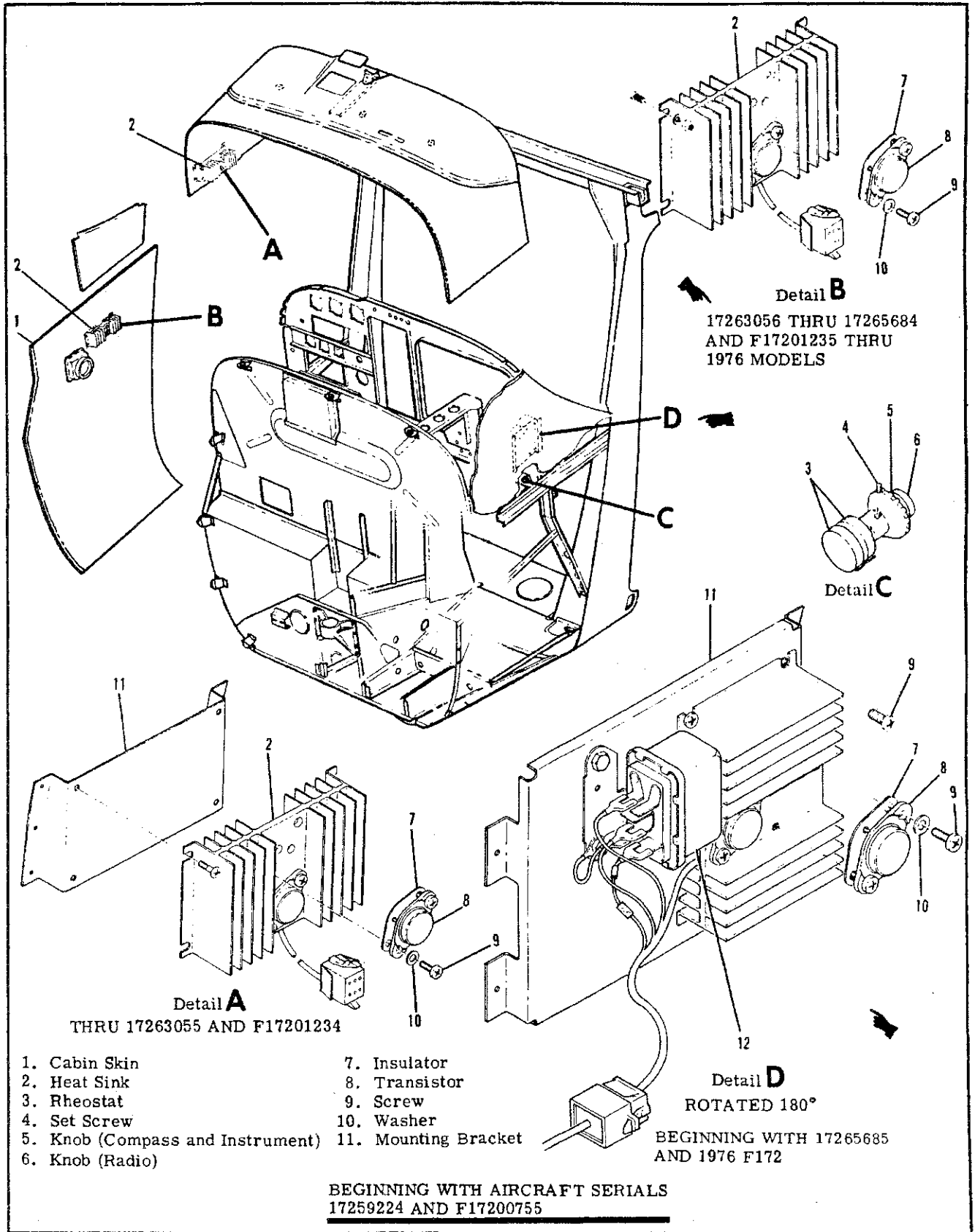

Figure 16-9A. Transistorized Dimming

16-72. REMOVAL AND INSTALLATION. For removal and installation of instrument, dome and courtesy lights refer to figure 16-9.

16-73. COMPASS AND RADIO DIAL LIGHTING.

16-74. DESCRIPTION. The compass and radio dial lights are contained within the individual units. Thru 1970 models the compass light is controlled by the instrument light dimming rheostat located on the right side of the overhead console and the radio dial lights are controlled by the radio dial light rheostat located on the left side of the overhead console. Beginning with 1971 models the compass and radio dial lights are controlled by the center portion of a concentric knob arrangement thru a dual rheostat assembly located on the pilot's switch panel.

16-75. TRANSISTORIZED LIGHT DIMMING. (Refer to figure 16-9A).

16-76. DESCRIPTION. Beginning with aircraft serials 17259224 and F17200755 a remotely located two-circuit transistorized dimming assembly is installed to control instrument, radio and compass lighting. One circuit controls instrument and compass lighting and the other circuit controls the radio lighting. This is accomplished by a concentric knob arrangement on the lower left hand side of the pilot's switch panel. The center portion of the knob controls the instrument and compass lighting and the outer portion controls the radio lighting.

16-76A. REMOVAL AND INSTALLATION. Refer to figure 16-9A for removal and installation of the transistorized dimming assembly.

16-77. MAP LIGHTING.

16-78. DESCRIPTION. White map lighting and red-non-glare instrument lighting are provided by an adjustable light mounted on the upper forward part of the left door post. The switch is a three position type with red, white and off positions. The map light contains a white bulb for general purpose lighting and a red bulb for adjustable instrument lighting. Thru 1970 models the intensity of the red bulb is controlled by the instrument light dimming rheostat on the overhead console. Beginning with 1971 models the intensity of the red bulb is controlled by the center portion of a concentric knob arrangement thru a dual rheostat assembly located on the pilot's switch panel.

16-79. REMOVAL AND INSTALLATION. (Refer to figure 16-10.)

a. For replacement of defective lamp slide the hood and lens from the map light assembly and remove the bayonet type bulb.

b. For removal of the map light assembly, remove the screws from the front door post shield. Remove the washer and nut attaching the map light. Remove the ground wire from the map light screw. Detach the wires at the quick disconnect fasteners and remove the map light assembly.

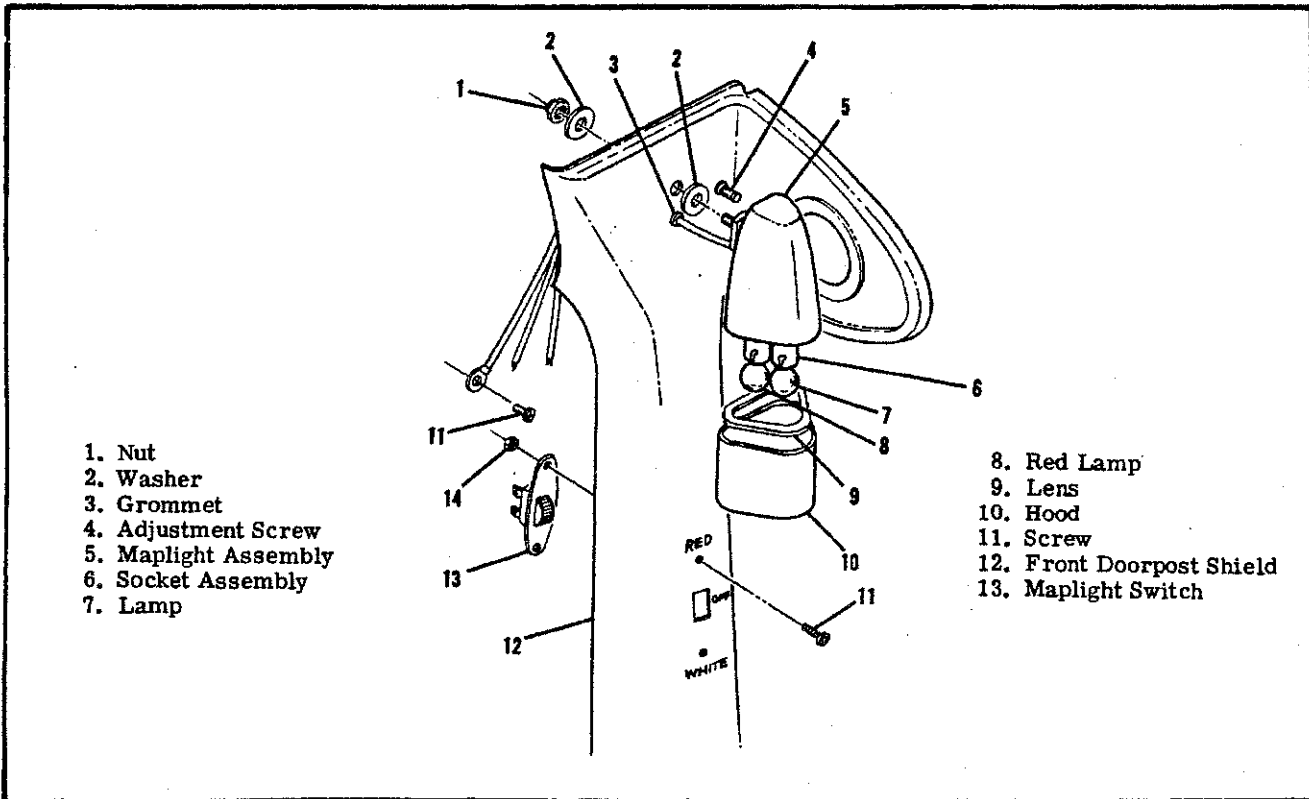

Figure 16-10. Map Light Installation

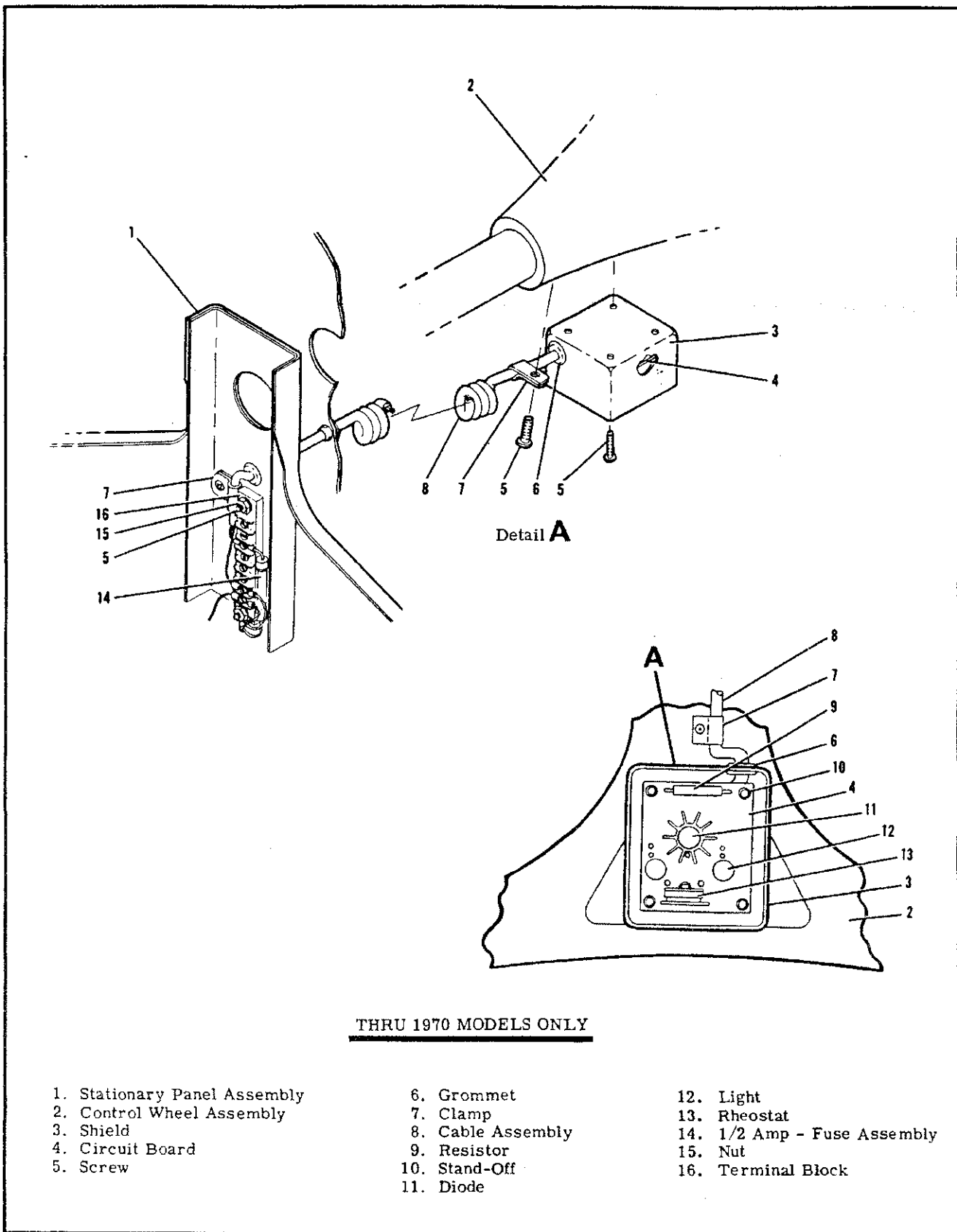
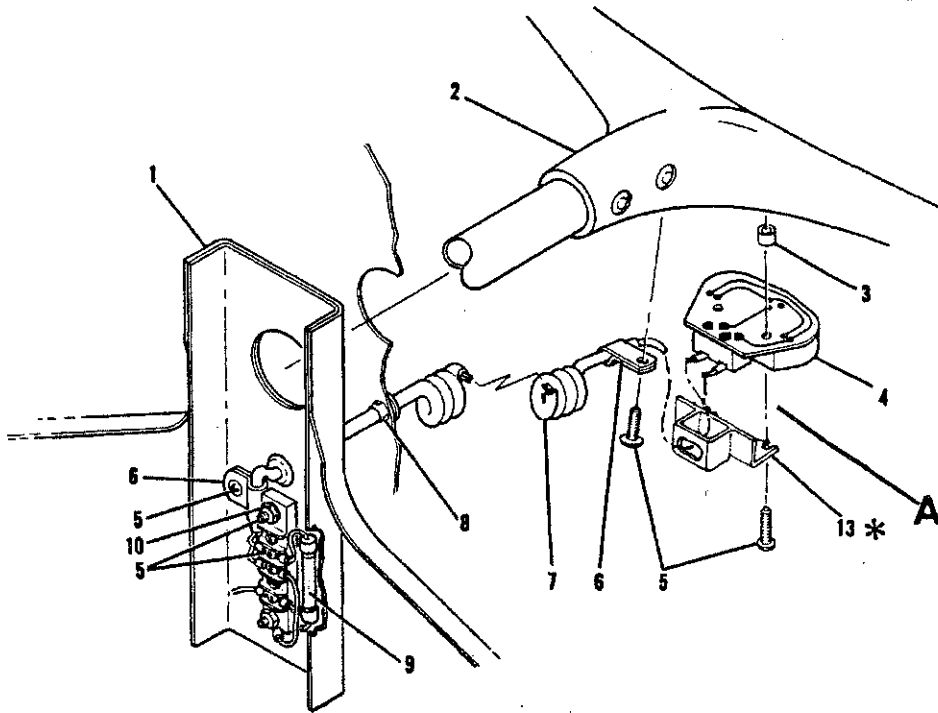
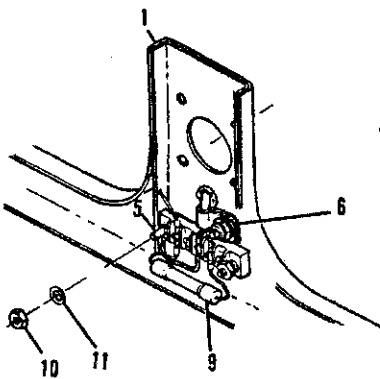

Figure 16-11. Control Wheel Map Light Installation (Sheet 1 of 2)

\* AIRCRAFT SERIALS 17259879 THRU  
17259903 AND 17259905 AND ON AND  
LATER F172 MODELS



THRU 1975 MODELS



BEGINNING WITH 1976 MODELS

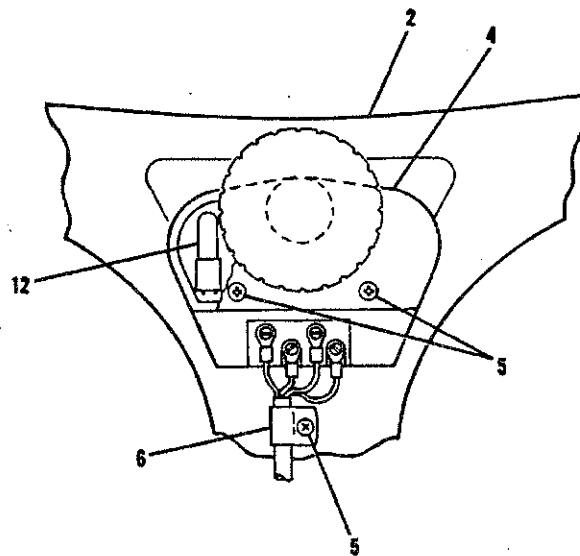

Detail A

1971 AND ON

1. Stationary Panel Assembly
2. Control Wheel Assembly
3. Spacer
4. Map Light Assembly
5. Screw
6. Clamp
7. Cable Assembly
8. Grommet
9. Fuse
10. Nut
11. Washer
12. Lamp
13. Cover

Figure 16-11. Control Wheel Map Light Installation (Sheet 2 of 2)

16-80. CONTROL WHEEL MAP LIGHT.

16-81. DESCRIPTION. An optional control wheel map light is available on the 172 model. The map light is mounted on the underside of the control wheel and the light intensity is controlled by a thumb operated rheostat. For dimming, the rheostat should be turned clockwise.

**CAUTION**

Thru 1970 aircraft only, failure to observe polarity shown on wiring diagram (page 20-38), will result in immediate failure of the transistor on the map light circuit board assembly.

16-82. REMOVAL AND INSTALLATION. (Thru 1970 Models) (Refer to Figure 16-11).

- a. For easy access to the map light assembly, rotate the control wheel 90°.
- b. Remove the four screws from the map light circuit board. The map light assembly will then be free for removal from the control wheel.
- c. Label the wires connecting to the map light circuit board assembly and remove the screws securing the wires to the circuit board assembly.
- d. To install the map light assembly, reverse this procedure.

16-83. REMOVAL AND INSTALLATION. (1971 Models and ON) (Refer to Figure 16-11).

- a. For easy access to the map light assembly rotate the control wheel 90°.

b. Label the wires connecting to the map light assembly (terminal block) and remove the screws securing the wires to the terminal block.

c. The assembly should now be free for removal. Remove the two screws securing the map light to the control wheel and remove the map light assembly.

d. For reassembly reverse this procedure.

16-84. PITOT HEATER

16-85. DESCRIPTION. An electrical heater unit is installed in some pitot tubes. The heater offsets the possibility of ice formations on the pitot tube. The heater is integrally mounted in the pitot tube and is operated by a pull type switch on the instrument panel. (See figure 16-12.)

16-86. CIGAR LIGHTER

16-87. DESCRIPTION. The cigar lighter (located on the instrument panel) is equipped with a thermal-actuated circuit breaker which is attached to the rear of the cigar lighter. The circuit breaker will open if the lighter becomes jammed in the socket or held in position too long. The circuit breaker may be reset by inserting a small probe into the .078 diameter hole in the back of the circuit breaker and pushing lightly until a click is heard.

**CAUTION**

Make sure master switch is "OFF" before inserting probe into circuit breaker on cigar lighter to reset.

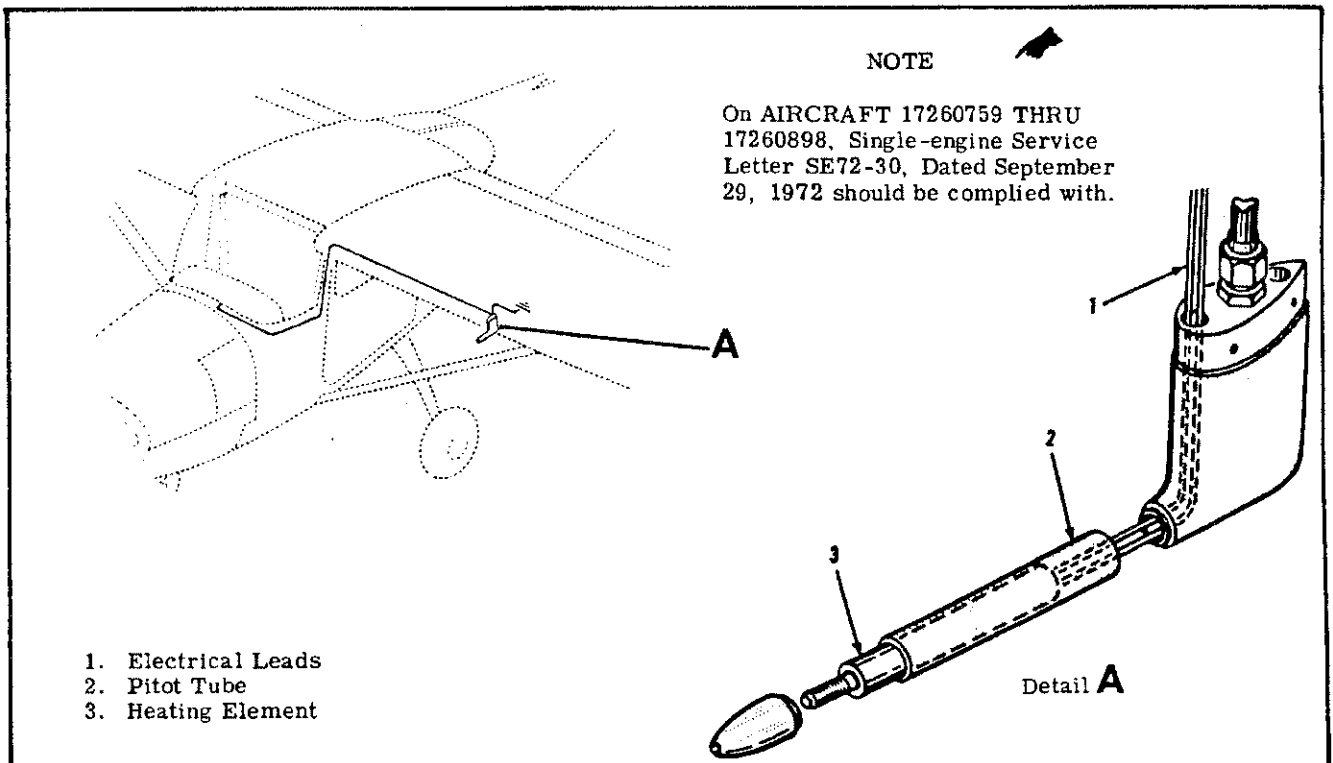

Figure 16-12. Pitot Heater Installation

16-88. EMERGENCY LOCATOR TRANSMITTER.

16-89. DESCRIPTION. The ELT is a self-contained, solid state unit, having its own power supply, with an externally mounted antenna. The C589510-0209 transmitter is designed to transmit simultaneously on dual emergency frequencies of 121.5 and 243.0 Megahertz. The C589510-0211 transmitter used for Canadian registry, operates on 121.5 only. The unit is mounted in the tailcone, aft of the baggage curtain on the right hand side. The transmitters are designed to provide a broadcast tone that is audio modulated in a swept manner over the range of 1600 to 300 Hz in a distinct, easily recognizable distress signal for reception by search and rescue personnel and others monitoring the emergency frequencies. Power is supplied to the transmitter by a battery pack which has the service life of the batteries placarded on the batteries and also on the outside end of the transmitter. ELT's thru early 1974 models, were equipped with a battery-pack containing six magnesium "D" size dry cell batteries wired in series. (See figure 16-14) Mid 1974 thru early 1975, ELT's are equipped with a battery-pack containing four "in-line" lithium "D" size batteries wired in series. Early 1975 and on ELT's are equipped with a battery-pack containing four lithium "D" size batteries which are stacked in two's (See figure 16-15). The ELT exhibits line of flight transmission characteristics which correspond approximately to 100 miles at a search altitude of 10,000 feet. When battery inspection and replacement schedules are adhered to, the transmitter will broadcast an emergency signal at rated power (75 MW-minimum), for a continuous period of time as listed in the following table.

TRANSMITTER LIFE  
TO 75 MILLIWATTS OUTPUT

Temperature	6 Cell Magnesium Battery Pack	4 Cell Lithium Battery Pack
+130°F	89 hrs	115 hrs
+ 70°F	95 hrs	115 hrs
- 4°F	49 hrs	95 hrs
- 40°F	23 hrs	70 hrs

Battery-packs have a normal shelf life of five to ten (5-10) years and must be replaced at 1/2 of normal shelf life in accordance with TSO-C91. Cessna specifies 3 years replacement of magnesium (6-cell) battery-packs and 5 years replacement of lithium (4-cell) battery packs.

16-90. OPERATION. A three position switch on the forward end of the unit controls operation. Placing the switch in the ON position will energize the unit to start transmitting emergency signals. In the OFF position, the unit is inoperative. Placing the switch in the ARM position will set the unit to start transmitting emergency signals only after the unit has received a 5g (tolerances are +2g and -0g) impact force, for a duration of 11-16 milliseconds.

**CAUTION**

Do not leave the emergency locator transmitter in the ON position longer than 5 seconds or you may activate downed aircraft procedures by C. A. P., D. O. T. or F. A. A. personnel.

**WARNING**

Magnesium (6-cell) battery-packs (excluding 4 cell lithium battery-packs) after prolonged continuous use (1 hour) in a sealed environment give off explosive gas. If your ELT has operated for this time period or longer, as a precautionary measure, loosen the ELT cover screws, lift the cover to break air tight seal and let stand for 15 minutes before tightening screws. Keep sparks, flames and lighted cigarettes away from battery-pack.

NOTE

After relatively short periods of inactivation, the magnesium (6-cell) battery-pack develops a coating over its anode which drastically reduces self discharge and thereby gives the cell an extremely long storage life. This coating will exhibit a high resistance to the flow of electric current when the battery is first switched on. After a short while (less than 15 seconds), the battery current will completely dissolve this coating and enable the battery to operate normally. If this coating is present when your ELT is activated, there may be a few seconds delay before the transmitter reaches full power.

16-91. CHECKOUT INTERVAL:

100 HOURS.

- a. Turn aircraft master switch ON.
- b. Turn aircraft transceiver ON and set frequency on receiver to 121.5 MHz.
- c. Remove the ELT's antenna cable from the ELT unit.
- d. Place the ELT's function selector switch in the ON position for 5 seconds or less. Immediately replace the ELT function selector switch in the ARM position after testing ELT.
- e. Test should be conducted only within the time period made up of the first five minutes after any hour.

**CAUTION**

Tests with the antenna connected should be approved and confirmed by the nearest control tower.

NOTE

Without its antenna connected, the ELT will produce sufficient signal to reach your receiver, yet it will not disturb other communications or damage output circuitry.

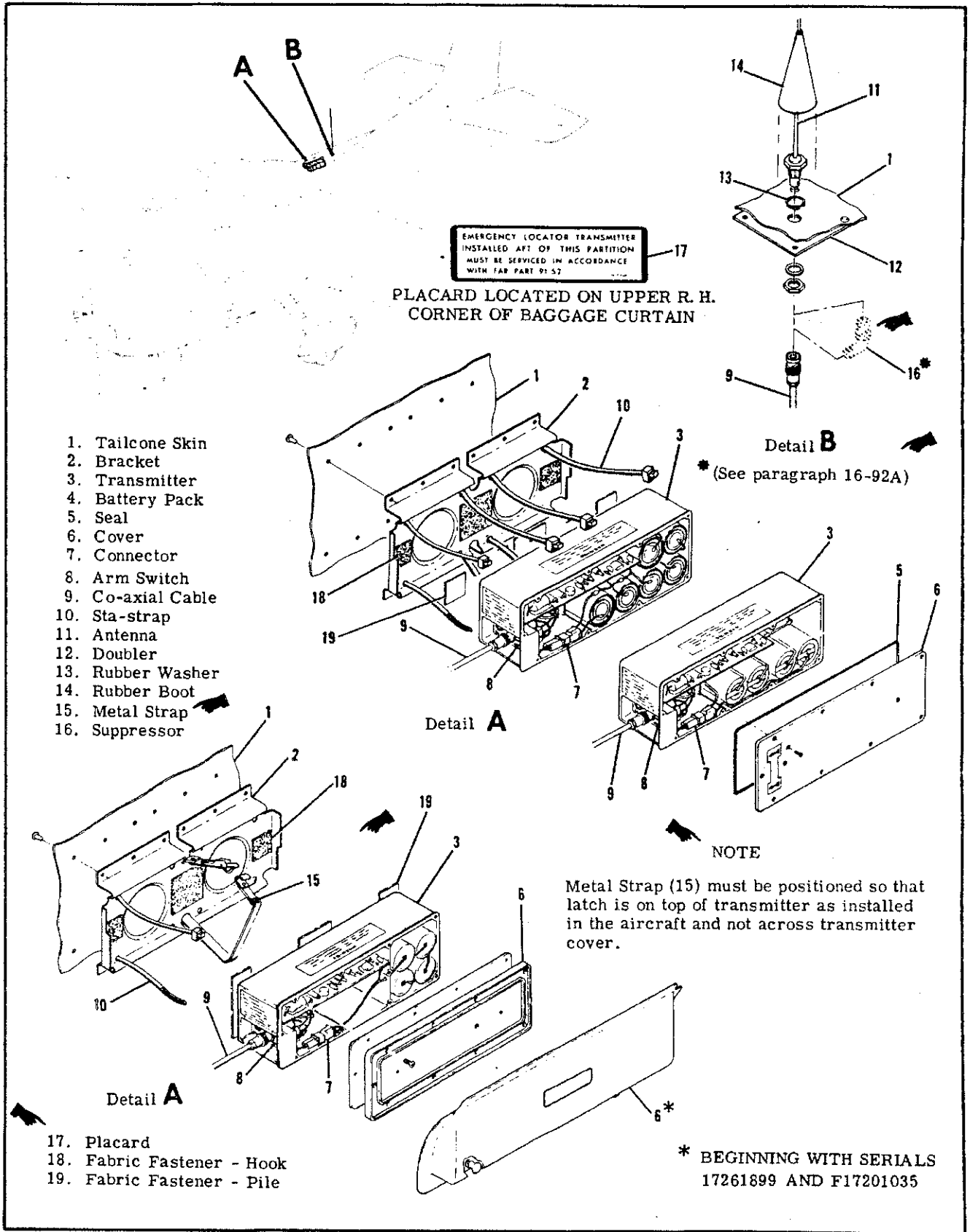

Figure 16-13. Emergency Locator Transmitter Installation

**NOTE**

After accumulated test or operation time equals 1 hour, battery-pack replacement is required.

f. Check calendar date for replacement of battery-pack. This date is supplied on a sticker attached to the outside of the ELT case and to each battery.

**16-92. REMOVAL AND INSTALLATION OF TRANSMITTER. (Refer to figure 16-13.)**

a. Thru 1973 Models remove baggage curtain to gain access to the transmitter and antenna.

b. Beginning with 1974 Models remove cover in the extended portion of the baggage compartment to gain access to the transmitter, remove screws securing baggage compartment overhead cover and remove cover to gain access to the antenna.

c. Disconnect co-axial cable from end of transmitter.

d. Depending upon the particular installation, either cut four sta-straps and remove transmitter or cut sta-strap securing antenna cable and unlatch metal strap to remove transmitter.

**NOTE**

Transmitter is also attached to the mounting bracket by velcro strips; pull transmitter to free from mounting bracket and velcro.

**NOTE**

To replace velcro strips, clean surface thoroughly with clean cloth saturated in one of the following solvents: Trichloric thylene, Aliphatic Napthas, Methyl Ethyl Ketone or Enmar 6094 Lacquer Thinner. Cloth should be folded each time the surface is wiped to present a clean area and avoid redepositing of grease. Wipe surface immediately with clean dry cloth, do not allow solvent to dry on surface. Apply Velcro #40 adhesive to each surface in a thin even coat and allow to dry until quite tacky, but no longer transfers to the finger when touched (usually between 5 and 30 minutes). Porous surfaces may require two coats. Place the two surfaces in contact and press firmly together to insure intimate contact. Allow 24 hours for complete cure.

e. To reinstall transmitter, reverse preceding steps.

**NOTE**

An installation tool is required to properly secure sta-straps on units installed with sta-straps. This tool may be purchased locally or ordered from the Pandiut Corporation, Tinley Park, Ill., part number GS-2B (Conforms to MS90387-1).

**CAUTION**

Ensure that the direction of flight arrows

(placarded on the transmitter) are pointing towards the nose of the aircraft.

**16-92A. REMOVAL AND INSTALLATION OF ANTENNA. (Refer to figure 16-13.)**

a. Disconnect co-axial cable from base of antenna.

b. Remove the nut and lockwasher attaching the antenna base of the fuselage and the antenna will be free for removal.

c. To reinstall the antenna, reverse the preceding steps.

**NOTE**

Upon reinstallation of antenna, cement rubber boot (14) using RTV102, General Electric Co. or equivalent, to antenna whip only; do not apply adhesive to fuselage skin or damage to paint may result.

**CAUTION**

In-service 6 cell magnesium battery-pack powered ELT's require the installation of a static electricity suppressor in the antenna cable to prevent the possibility of damage to the case of the ELT. Refer to Cessna Avionics Service Letter AV74-16 and figure 16-13.

**16-93. REMOVAL AND INSTALLATION OF MAGNESIUM SIX (6) CELL BATTERY-PACK. (Refer to figure 16-14.)**

**NOTE**

Since replacement 6 cell magnesium battery-packs are no longer available, when in-service units require replacement, use the 4 cell lithium battery-pack. Refer to paragraph 16-94.

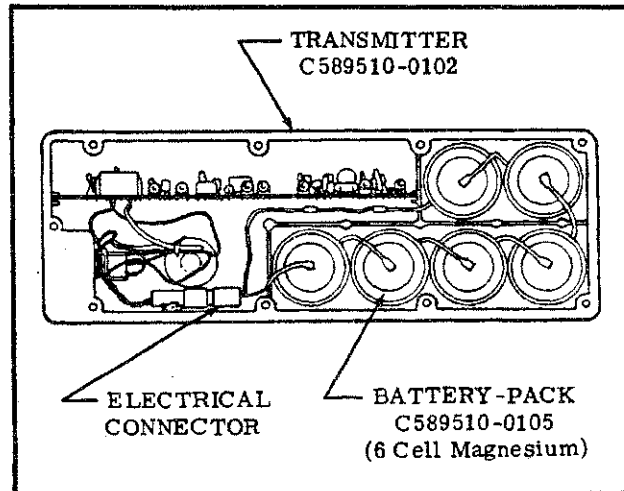

Figure 16-14. Magnesium 6 Cell Battery-Pack Installation

**16-94. REMOVAL AND INSTALLATION OF LITHIUM FOUR (4) CELL BATTERY-PACK. (Refer to figure 16-15.)**



**NOTE**

Transmitters equipped with the 4 cell battery-pack can only be replaced with another 4 cell battery-pack.

- a. After the transmitter has been removed from aircraft in accordance with para. 16-92, place the transmitter switch in the OFF position.
- b. Remove the nine screws attaching the cover to the case and then remove the cover to gain access to the battery-pack.

**NOTE**

Retain the rubber "O" ring gasket, rubber washers and screws for reinstallation.

- c. Disconnect the battery-pack electrical connector and remove battery-pack.
- d. Place new battery-pack in the transmitter with four batteries as shown in the case in figure 16-15.
- e. Connect the electrical connector as shown in figure 16-15.

**NOTE**

Before installing the new 4 cell battery-pack, check to ensure that its voltage is 11.2 volts or greater.

**CAUTION**

If it is desirable to replace adhesive material on the 4 cell battery-pack, use only 3M Jet Melt Adhesive #3738. Do not use other adhesive materials since other materials may corrode the printed circuit board assembly.

- f. Replace the transmitter cover by positioning the rubber "O" ring gasket, if installed, on the cover and pressing the cover and case together. Attach cover with nine screws and rubber washers.
- g. Remove the old battery-pack placard from the end of transmitter and replace with new battery-pack placard supplied with the new battery-pack.

**CAUTION**

Be sure to enter the new battery-pack expiration date in the aircraft records. It is also recommended this date be placed in your ELT Owner's Manual for quick reference.

tion date in the aircraft records. It is also recommended this date be placed in your ELT Owner's Manual for quick reference.

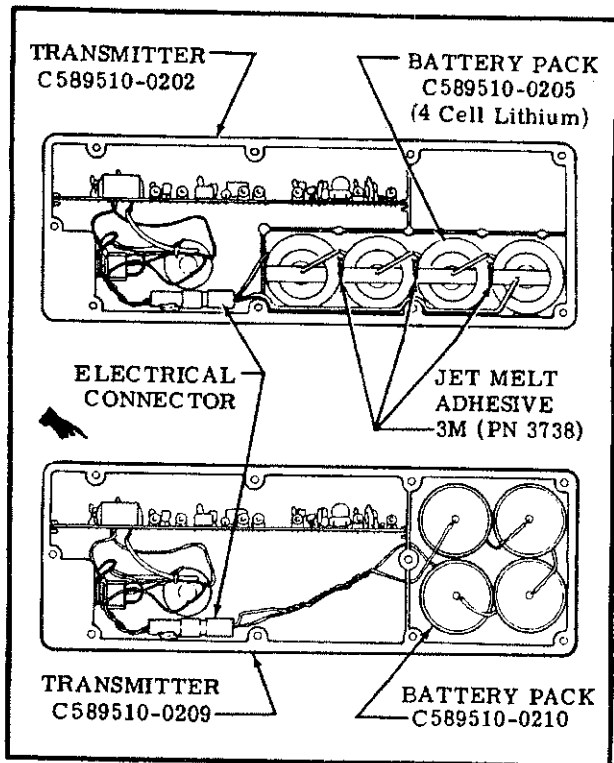

Figure 16-15. Lithium 4 Cell Battery Pack Installations

16-95. TROUBLE SHOOTING. Should your Emergency Locating Transmitter fail the 100 Hours performance checks, it is possible to a limited degree to isolate the fault to a particular area of the equipment. In performing the following trouble shooting procedures to test peak effective radiated power, you will be able to determine if battery replacement is necessary or if your unit should be returned to your dealer for repair.

**SHOP NOTES:**

---

---

---

---

TROUBLE	PROBABLE CAUSE	REMEDY
*POWER LOW	Low battery voltage.	<ol style="list-style-type: none"> <li>1. Set toggle switch to off.</li> <li>2. Remove plastic plug from the remote jack and by means of a Switchcraft #750 jackplug, connect a Simpson 260 model voltmeter and measure voltage. If the battery-pack voltage on the 6-cell magnesium battery pack transmitter is 10.8 volts or less, and on the 4-cell lithium battery pack transmitters is 11.2 volts or less, the battery pack is below specification.</li> </ol>
	Faulty transmitter.	<ol style="list-style-type: none"> <li>3. If the battery-pack voltage meets the specifications in step 2, the battery-pack is O. K. If the battery is O. K., check the transmitter as follows:               <ol style="list-style-type: none"> <li>a. Remove the voltmeter.</li> <li>b. By means of a switchcraft 750 jackplug and 3 inch maximum long leads, connect a Simpson Model 1223 ammeter to the jack.</li> <li>c. Set the toggle switch to ON and observe the ammeter current drain. If the current-drain is in the 85-100 ma range, the transmitter or the co-axial cable is faulty.</li> </ol> </li> </ol>
	Faulty co-axial antenna cable.	<ol style="list-style-type: none"> <li>4. Check co-axial antenna cable for high resistance joints. If this is found to be the case, the cable should be replaced.</li> </ol>

\*This test should be carried out with the co-axial cable provided with your unit.

## SHOP NOTES:

---



---



---



---



---



---



---



---

ELECTRICAL LOAD ANALYSIS CHART

STANDARD EQUIPMENT (RUNNING LOAD)	AMPS REQD							
	1969	1970	1971	1972	1973	1974	1975	1976
Battery Contactor . . . . .	0.6	0.6	0.6	0.6	0.6	0.6	0.6	0.6
Fuel Indicators . . . . .	0.4	0.4	0.4	0.4	0.4	0.4	0.4	0.4
Flashing Beacon Light . . . . .	7.0	7.0	7.0	7.0	7.0	7.0	7.0	7.0
Instrument Lights. . . . .	1.1	1.1	1.1	1.1	1.1	1.1	1.1	1.3
Position Lights . . . . .	5.6	5.6	5.6	5.6	5.6	5.6	5.6	5.6
Turn Coordinator . . . . .	0.8	0.8	0.8	0.8	0.8	0.8	0.8	0.8
Flap Position Indicator . . . . .	0.1	0.1	0.1	0.1	0.1	0.1	0.1	0.1
<b>OPTIONAL EQUIPMENT (RUNNING LOAD)</b>								
Strobe Lights. . . . .	—	—	—	—	—	3.0	3.0	4.0
Cessna 300 ADF (Type R-521B) . . . . .	1.6	1.6	1.6	1.6	—	—	—	—
Cessna 300 ADF (Type R-547A) . . . . .	—	—	—	1.0	1.0	1.0	1.0	—
Cessna 300 ADF (Type R-546E) . . . . .	—	—	—	1.0	1.0	1.0	1.0	1.0
Cessna 300 Marker Beacon (Type R-502B) . . . . .	.02	.02	.02	.02	.02	.02	—	—
Cessna 300 Nav/Com (90 Channel-Type RT-517R) . . . . .	4.5	4.5	4.5	—	—	—	—	—
Cessna 300 Nav/Com (360 Channel-Type RT-540A) . . . . .	4.5	4.5	4.5	—	—	—	—	—
Cessna 300 Nav/Com (100 Channel-Type RT-508A) . . . . .	—	—	—	1.9	1.9	—	—	—
Cessna 300 Nav/Com (100 Channel-Type RT-308C) . . . . .	—	—	—	—	—	1.5	1.5	1.5
Cessna 300 Nav/Com (360 Channel-Type RT-528A) . . . . .	—	—	—	1.9	1.9	—	—	—
Cessna 300 Nav/Com (360 Channel-Type RT-528E) . . . . .	—	—	—	—	1.9	1.9	1.9	—
Cessna 300 Nav/Com (360 Channel-Type RT-328A) . . . . .	—	—	—	—	1.9	—	—	—
Cessna 300 Nav/Com (360 Channel-Type RT-328C) . . . . .	—	—	—	—	—	1.5	—	—
Cessna 300 Nav/Com (720 Channel-Type RT-328D) . . . . .	—	—	—	—	—	—	1.5	—
Cessna 300 HF Transceiver (PT10-A) . . . . .	—	—	—	—	—	1.5	1.5	1.5
Cessna 300 Transceiver (Type RT-524A) . . . . .	3.2	3.2	3.2	3.2	3.2	3.2	3.2	3.2
Cessna 300 Transponder (Type KT-75R) . . . . .	1.5	1.5	1.5	1.5	—	—	—	—
Cessna 300 Transponder (Types KT-76 or KT-78) . . . . .	—	—	—	1.3	1.3	1.3	1.3	—
Cessna 300 Transponder (RT-359A) . . . . .	—	—	—	—	—	1.0	1.0	1.0
Cessna 400 Glideslope (Type R-542B) . . . . .	0.5	0.5	0.5	0.5	—	—	—	—
Cessna 400 Glideslope (Type R-443A) . . . . .	—	—	—	—	0.4	—	—	—
Cessna 400 Glideslope (Type R-443B) (40 Channel) . . . . .	—	—	—	—	—	.4	.4	.4
Cessna 400 Marker Beacon (Type R-402A) . . . . .	—	—	—	—	—	—	.3	.3
King KY-95 or KY-95F** . . . . .	4.0	4.0	4.0	—	—	—	—	—
King KX-160E, AE or FE ** . . . . .	2.5	2.5	2.5	—	—	—	—	—
King KX-160-1 ** . . . . .	—	2.5	2.5	—	—	—	—	—
Narco Mark 12A Nav/Com . . . . .	4.6	—	—	—	—	—	—	—
Narco Mark 12B with VOA-40 or VOA-50* . . . . .	—	4.6	4.6	—	—	—	—	—
Sunair SS Band HF Transceiver (Type ASB-125) . . . . .	—	5.0	5.0	5.0	5.0	5.0	5.0	5.0
Cessna 300 DME (Type KN-60B) . . . . .	3.0	3.0	3.0	—	—	—	—	—
Cessna 300 DME (Type KN-60C) . . . . .	—	—	—	3.0	3.0	3.0	3.0	—
Cessna 300 Navomatic (Type AF-512C) . . . . .	2.0	2.0	2.0	—	—	—	—	—
Cessna 300 Navomatic (Type AF-512D) . . . . .	—	—	—	2.0	—	—	—	—
Cessna 300 Navomatic (Type AF-394A) . . . . .	—	—	—	—	1.75	1.75	—	—
Cessna 300A Navomatic (Type AF-395A) . . . . .	—	—	—	—	—	—	2.0	2.0
Cessna 200 Navomatic (Type AF-295A) . . . . .	—	—	—	—	—	2.0	—	—
Cessna 200 Navomatic (Type AF-295B) . . . . .	—	—	—	—	—	—	2.0	2.0
Cessna EA-401A Encoding Altimeter . . . . .	—	—	—	—	—	—	.065	.065
Cessna 300 Nav/Com (360 Channel-RT-528-1) . . . . .	—	—	—	—	—	—	—	1.9
Cessna 300 Nav/Com (720 Channel-RT-328T) . . . . .	—	—	—	—	—	—	—	1.5
Narco 190 DME . . . . .	—	—	—	—	—	—	—	3.0

†Negligible  
 \*Available on 172 Models only.  
 \*\*Available on F172 Models only.

ELECTRICAL LOAD ANALYSIS CHART (CONT.)

ITEMS NOT CONSIDERED AS PART OF RUNNING LOAD	AMPS REQD							
	1969	1970	1971	1972	1973	1974	1975	1976
Cigarette Lighter . . . . .	10.0	10.0	10.0	10.0	10.0	10.0	10.0	10.0
Clock . . . . .	†	†	†	†	†	†	†	†
Control Wheel Map Light . . . . .	.33	.33	.33	.33	.33	.33	.33	.33
Courtesy & Dome Lights . . . . .	2.5	2.5	2.5	2.5	2.5	2.5	2.5	2.5
Flap Motor . . . . .	15.0	15.0	15.0	15.0	15.0	15.0	15.0	15.0
Landing Lights . . . . .	15.6	15.6	—	—	—	—	—	—
Landing and Taxi Light (Cowl Mounted) . . . . .	—	—	18.0	20.0	20.0	20.0	20.0	20.0
Landing and Taxi Lights (Cowl Mounted) . . . . .	—	—	—	—	—	15.6	15.6	15.6
Map Light . . . . .	.33	.33	.33	.33	.33	.33	.33	.33

†Negligible  
 \*Available on 172 Models only.  
 \*\*Available on F172 Models only.

SECTION 18

STRUCTURAL REPAIR

TABLE OF CONTENTS

Page

STRUCTURAL REPAIR . . . . .	18-1	Wing Leading Edge . . . . .	18-4
Repair Criteria . . . . .	18-1	Negligible Damage . . . . .	18-4
Equipment and Tools . . . . .	18-2	Repairable Damage . . . . .	18-4
Support Stands . . . . .	18-2	Damage Necessitating Replace-	
Fuselage Repair Jigs . . . . .	18-2	ment of Parts . . . . .	18-4
Wing Jigs . . . . .	18-2	Elevators and Rudder . . . . .	18-4
Wing Twist and Stabilizer Angle-of-		Negligible Damage . . . . .	18-4
Incidence . . . . .	18-2	Repairable Damage . . . . .	18-4
Repair Materials . . . . .	18-2	Damage Necessitating Replace-	
Wing . . . . .	18-2	ment of Parts . . . . .	18-4
Description . . . . .	18-2	Elevator and Rudder Balancing . . . . .	18-4
Wing Skin . . . . .	18-2	Fin and Stabilizer . . . . .	18-4
Negligible Damage . . . . .	18-2	Negligible Damage . . . . .	18-4
Repairable Damage . . . . .	18-2	Repairable Damage . . . . .	18-4
Damage Necessitating Replace-		Damage Necessitating Replace-	
ment of Parts . . . . .	18-3	ment of Parts . . . . .	18-4
Wing Stringers . . . . .	18-3	Fuselage . . . . .	18-4
Negligible Damage . . . . .	18-3	Description . . . . .	18-4
Repairable Damage . . . . .	18-3	Negligible Damage . . . . .	18-4
Damage Necessitating Replace-		Repairable Damage . . . . .	18-5
ment of Parts . . . . .	18-3	Damage Necessitating Replace-	
Wing Auxiliary Spars . . . . .	18-3	ment of Parts . . . . .	18-5
Negligible Damage . . . . .	18-3	Bonded Doors . . . . .	18-5
Repairable Damage . . . . .	18-3	Repairable Damage . . . . .	18-5
Damage Necessitating		Bulkheads . . . . .	18-5
Replacement of Parts . . . . .	18-3	Landing Gear Bulkheads . . . . .	18-5
Wing Ribs . . . . .	18-3	Repair After Hard Landing . . . . .	18-5
Negligible Damage . . . . .	18-3	Replacement of Hi-Shear Rivets . . . . .	18-5
Repairable Damage . . . . .	18-3	Firewall Damage . . . . .	18-5
Damaging Necessitating Replace-		Engine Mount . . . . .	18-5
ment of Parts . . . . .	18-3	Description . . . . .	18-5
Wing Spars . . . . .	18-3	General Considerations . . . . .	18-5
Negligible Damage . . . . .	18-3	Engine Mount Support Cradle	
Repairable Damage . . . . .	18-3	Damage . . . . .	18-5
Damage Necessitating Replace-		Damage Involving Engine Mount-	
ment of Parts . . . . .	18-3	ing Lugs and Engine Mount to	
Ailerons . . . . .	18-3	Fuselage Attach Fittings . . . . .	18-5
Negligible Damage . . . . .	18-3	Baffles . . . . .	18-5
Repairable Damage . . . . .	18-3	Engine Cowling . . . . .	18-5
Damaging Necessitating Replace-		Repair of Cowling Skins . . . . .	18-5
ment of Parts . . . . .	18-3	Repair of Reinforcement	
Aileron Balancing . . . . .	18-3	Angeles . . . . .	18-6
Wing Flaps . . . . .	18-3	Repair of ABS Components . . . . .	18-6
Negligible Damage . . . . .	18-3	Repair of Glass-Fiber	
Repairable Damage . . . . .	18-3	Constructed Components . . . . .	18-7
Damage Necessitating Replace-			
ment of Parts . . . . .	18-3		

18-1. STRUCTURAL REPAIR.

18-2. REPAIR CRITERIA. Although this section outlines repair permissible on structure of the aircraft, the decision of whether to repair or replace a major unit of structure will be influenced by such

factors as time and labor available, and by a comparison of labor costs with the price of replacement assemblies. Past experience indicates that replacement, in many cases, is less costly than major repair. Certainly, when the aircraft must be restored to its airworthy condition in a limited length of time,

replacement is preferable. Restoration of a damaged aircraft to its original design strength, shape, and alignment involves careful evaluation of the damage, followed by exacting workmanship in performing the repairs. This section suggests the extent of structural repair practicable on the aircraft, and supplements Federal Aviation Regulation, Part 43. Consult the factory when in doubt about a repair not specifically mentioned here.

**18-3. EQUIPMENT AND TOOLS.**

**18-4. SUPPORT STANDS.** Padded, reinforced sawhorse or tripod type support stands, sturdy enough to support any assembly placed upon them, must be used to store a removed wing or tailcone. Plans for local fabrication of support stands are contained in figure 18-1. The fuselage assembly, from the tailcone to the firewall, must NOT be supported from the underside, since the skin bulkheads are not designed for this purpose. Adapt support stands to fasten to the wing attach points or landing gear attach points when supporting a fuselage.

**18-5. FUSELAGE REPAIR JIGS.** Whenever a repair is to be made which could affect structural alignment, suitable jigs must be used to assure correct alignment of major attach points, such as fuselage, firewall, wing and landing gear. These fuselage repair jigs are obtainable from the factory.

**18-6. WING JIGS.** These jigs serve as a holding fixture during extensive repair of a damaged wing, and locates the root rib, leading edge and tip rib of the wing. These jigs are also obtainable from the factory.

**18-7. WING TWIST AND STABILIZER ANGLE-OF-INCIDENCE.**

**18-8.** Wing twist (washout) and horizontal stabilizer angle of incidence are shown below. Stabilizers do not have twist. Wings have no twist from the root to the lift strut station. All twist in the wing panel occurs between this station and the tip rib. Refer to figure 18-2 for wing twist measurement.

<b>WING</b>	Twist (Washout)	3°
<b>STABILIZER</b>	Angle of Incidence	-3° 30'

**18-9. REPAIR MATERIALS.** Thickness of a material on which a repair is to be made can easily be determined by measuring with a micrometer. In general, material used in Cessna aircraft covered in this manual is made from 2024 aluminum alloy, heat treated to a -T3, -T4, or -T42 condition. If the type of material cannot readily be determined, 2024-T3 may be used in making repairs, since the strength of -T3 is greater than -T4 or -T42 (-T4 and -T42 may be used interchangeably, but they may not be substituted for -T3). When necessary to form a part with a smaller bend radius than the standard cold bending radius for 2024-T4, use 2024-O and heat treat to 2024-T42 after forming. The repair material used in making a repair must equal the gauge of the material being replaced unless otherwise noted. It is often practical to cut repair pieces from service parts listed in the Parts Catalog. A few components (empennage tips, for example) are fabricated from thermo-formed plastic or glass-fiber constructed material.

**18-10. WING.**

**18-11. DESCRIPTION.** The wing assemblies are a semicantilever type employing semimonocoque type of structure. Basically, the internal structure consists of built-up front and rear spar assemblies, a formed auxiliary spar assembly and formed sheet metal nose, intermediate, and trailing edge ribs. Stressed skin, riveted to the rib and spar structures, completes the rigid structure. Access openings (hand holes with removable cover plates) are located in the underside of the wing between the wing root and tip section. These openings afford access to aileron bellcranks, flap bellcranks, electrical wiring, strut attach fittings, control cables and pulleys, and control disconnect points.

**18-12. WING SKIN.**

**18-13. NEGLIGIBLE DAMAGE.** Any smooth dents in the wing skin that are free from cracks, abrasions and sharp corners, which are not stress wrinkles and do not interfere with any internal structure or mechanism, may be considered as negligible damage. In areas of low stress intensity, cracks, deep scratches, or deep, sharp dents, which after trimming or stop-drilling can be enclosed by a two-inch circle, can be considered negligible if the damaged area is at least one diameter of the enclosing circle away from all existing rivet lines and material edges. Stop drilling is considered a temporary repair and a permanent repair must be made as soon as practicable.

**18-14. REPAIRABLE DAMAGE.** Figure 18-4 outlines typical repair to be employed in patching skin. Before installing a patch, trim the damaged area to form a rectangular pattern, leaving at least a one-half inch radius at each corner, and de-burr. The sides of the hole should lie span-wise or chord-wise. A circular patch may also be used. If the patch is in an area where flush rivets are used, make a flush patch type of repair; if in an area where flush rivets

are not used, make an overlapping type of repair. Where optimum appearance and airflow are desired, the flush patch may be used. Careful workmanship will eliminate gaps at butt-joints; however, an epoxy type filler may be used at such joints.

18-15. **DAMAGE NECESSITATING REPLACEMENT OF PARTS.** If a skin is badly damaged, repair must be made by replacing an entire skin panel, from one structural member to the next. Repair seams must be made to lie along structural members and each seam must be made exactly the same in regard to rivet size, spacing, and pattern as the manufactured seams at the edges of the original sheet. If the manufactured seams are different, the stronger must be copied. If the repair ends at a structural member where no seam is used, enough repair panel must be used to allow an extra row of staggered rivets, with sufficient edge margin, to be installed.

18-16. **WING STRINGERS.**

18-17. **NEGLIGIBLE DAMAGE.** Refer to paragraph 18-13.

18-18. **REPAIRABLE DAMAGE.** Figure 18-5 outlines a typical wing stringer repair. Two such repairs may be used to splice a new section of stringer material in position, without the filler material.

18-19. **DAMAGE NECESSITATING REPLACEMENT OF PARTS.** If a stringer is so badly damaged that more than one section must be spliced, replacement is recommended.

18-20. **WING AUXILIARY SPARS.**

18-21. **NEGLIGIBLE DAMAGE.** Refer to paragraph 18-13.

18-22. **REPAIRABLE DAMAGE.** Figure 18-8 illustrates a typical auxiliary spar repair.

18-23. **DAMAGE NECESSITATING REPLACEMENT OF PARTS.** If damage to an auxiliary spar would require a repair which could not be made between adjacent ribs, the auxiliary spar must be replaced.

18-24. **WING RIBS.**

18-25. **NEGLIGIBLE DAMAGE.** Refer to paragraph 18-13.

18-26. **REPAIRABLE DAMAGE.** Figure 18-6 illustrates a typical wing rib repair.

18-27. **DAMAGE NECESSITATING REPLACEMENT OF PARTS.** Leading and trailing edge ribs that are extensively damaged can be replaced. However, due to the necessity of unfastening an excessive amount of skin in order to replace the rib, they should be repaired if practicable. Center ribs, between the front and rear spar should always be repaired if practicable.

18-28. **WING SPARS.**

18-29. **NEGLIGIBLE DAMAGE.** Due to the stress

which wing spars encounter, very little damage can be considered negligible. All cracks, stress wrinkles, deep scratches, and sharp dents must be repaired. Smooth dents, light scratches and abrasions may be considered negligible.

18-30. **REPAIRABLE DAMAGE.** Figure 18-7 illustrates typical spar repairs. It is often practical to cut repair pieces from service parts listed in the Parts Catalog. Service Kits are available for certain types of spar repairs.

18-31. **DAMAGE NECESSITATING REPLACEMENT OF PARTS.** Damage so extensive that repair is not practicable requires replacement of a complete wing spar. Also refer to paragraph 18-2.

18-32. **AILERONS.**

18-33. **NEGLIGIBLE DAMAGE.** Refer to paragraph 18-13.

18-34. **REPAIRABLE DAMAGE.** The repair shown in figure 18-9 may be used to repair damage to aileron leading edge skins. Figure 18-4 may be used to repair damage to flat surfaces between corrugations, when damage area includes corrugations refer to figure 18-3A. It is recommended that material used for repair be cut from spare parts of the same gauge and corrugation spacing. Following repair the aileron must be balanced. Refer to paragraph 18-36 and figure 18-3 for balancing the aileron. If damage would require a repair which could not be made between adjacent ribs, see the following paragraph.

18-35. **DAMAGE NECESSITATING REPLACEMENT OF PARTS.** If the damage would require a repair which could not be made between adjacent ribs, complete skin panels must be replaced. Ribs and spars may be repaired, but replacement is generally preferable. Where extensive damage has occurred, replacement of the aileron assembly is recommended. After repair and/or replacement, balance aileron in accordance with paragraph 18-36 and figure 18-3.

18-36. **AILERON BALANCING.** Following repair, replacement or painting, the aileron must be balanced. Complete instructions for fabricating balancing fixtures and mandrels and their use are given in figure 18-3.

18-37. **WING FLAPS.**

18-38. **NEGLIGIBLE DAMAGE.** Refer to paragraph 18-13.

18-39. **REPAIRABLE DAMAGE.** Flap repairs should be similar to aileron repairs discussed in paragraph 18-34. A flap leading edge repair is shown in figure 18-10. If an overlapping patch is to be used, be sure it will not interfere with the wing during flap operation.

18-40. **DAMAGE NECESSITATING REPLACEMENT OF PARTS.** Flap repairs which require replacement of parts should be similar to aileron repairs discussed in paragraph 18-35. Since the flap is not considered a moveable control surface, no balancing is required.

18-41. WING LEADING EDGE.

18-42. NEGLIGIBLE DAMAGE. Refer to paragraph 18-13.

18-43. REPAIRABLE DAMAGE. A typical leading edge skin repair is shown in figure 18-9. An epoxy-type filler may be used to fill gaps at butt-joints. To facilitate repair, extra access holes may be installed in the locations noted in figure 18-11. If the damage would require a repair which could not be made between adjacent ribs, refer to the following paragraph.

18-44. DAMAGE NECESSITATING REPLACEMENT OF PARTS. For extensive damage, complete leading edge skin panels must be replaced. To facilitate replacement, extra access holes may be installed in the locations noted in figure 18-11.

18-45. ELEVATORS AND RUDDER.

18-46. NEGLIGIBLE DAMAGE. Refer to paragraph 18-13. The exception to negligible damage on the elevator surfaces is the front spar, where a crack appearing in the web at the hinge fittings or in the structure which supports the overhanging balance weight is not considered negligible. Cracks in the overhanging tip rib, in the area at the front spar intersection with the web of the rib, also cannot be considered negligible.

18-47. REPAIRABLE DAMAGE. Skin patches illustrated in figure 18-4 may be used to repair skin damage between corrugations. For skin damage which includes corrugations, refer to figure 18-3A. Following repair the elevator/rudder must be balanced. Refer to figure 18-3 for balancing. If damage would require a repair which could not be made between adjacent ribs, see the following paragraph.

18-48. DAMAGE NECESSITATING REPLACEMENT OF PARTS. If the damaged area would require a repair which could not be made between adjacent ribs, complete skin panels must be replaced. Ribs and spars may be repaired, but replacement is generally preferable. Where extensive damage has occurred, replacement of the entire assembly is recommended. After repair and/or replacement, balance elevators and rudder in accordance with paragraph 18-49 and figure 18-3.

18-49. ELEVATOR AND RUDDER BALANCING. Following repair, replacement or painting, the elevators and rudder must be balanced. Complete instructions for fabricating balancing fixtures and mandrels and their use are given in figure 18-3.

18-50. FIN AND STABILIZER.

18-51. NEGLIGIBLE DAMAGE. Refer to paragraph 18-13.

18-52. REPAIRABLE DAMAGE. Skin patches illustrated in figure 18-4 may be used to repair skin damage. Access to the dorsal area of the fin may be gained by removing the horizontal closing rib at the

bottom of the fin. Access to the internal fin structure is best gained by removing skin attaching rivets on one side of the rear spar and ribs, and springing back the skin. Access to the stabilizer structure may be gained by removing skin attaching rivets on one side of the rear spar and ribs, and springing back the skin. If the damaged area would require a repair which could not be made between adjacent ribs, or a repair would be located in an area with compound curves, see the following paragraph.

18-53. DAMAGE NECESSITATING REPLACEMENT OF PARTS. If the damaged area would require a repair which could not be made between adjacent ribs, or the repair would be located in an area with compound curves, complete skin panels must be replaced. Ribs and spars may be repaired, but replacement is generally preferable. Where damage is extensive, replacement of the entire assembly is recommended.

18-54. FUSELAGE.

18-55. DESCRIPTION. The fuselage is of semi-monocoque construction, consisting of formed bulkheads, longitudinal stringers, reinforcing channels, and skin panels.

18-56. NEGLIGIBLE DAMAGE. Refer to paragraph 18-13. Mild corrosion appearing upon alclad surfaces does not necessarily indicate incipient failure of the base metal. However, corrosion of all types must be carefully considered, and approved remedial action taken. Small cans appear in the skin structure of all metal aircraft. It is strongly recommended however, that wrinkles which appear to have originated from other sources, or which do not follow the general appearance of the remainder of the skin panels, be thoroughly investigated. Except in the landing gear bulkhead areas, wrinkles occurring over stringers which disappear when the rivet pattern is removed, may be considered negligible. However, the stringer rivet holes may not align perfectly with the skin holes because of a permanent "set" in the stringer. If this is apparent, replacement of the stringer will usually restore the original strength characteristics of the area.

#### NOTE

Wrinkles occurring in the skin of the main landing gear bulkhead areas must not be considered negligible. The skin panel must be opened sufficiently to permit a thorough examination of the lower portion of the landing gear bulkhead and its tie-in structure.

Wrinkles occurring in open areas which disappear when the rivets at the edge of the sheet are removed, or a wrinkle which is hand removable, may often be repaired by the addition of a 1/2 x 1/2 x .060 inch 2024-T4 extruded angle, riveted over the wrinkle and extended to within 1/16 to 1/8 inch of the nearest structural members. Rivet pattern should be identical to existing manufactured seam at edge of sheet. Negligible damage to stringers, formed skin flanges, bulkhead channels, and like parts is similar to that for the wing skin, given in paragraph 18-13.



18-57. REPAIRABLE DAMAGE. Fuselage skin repairs may be accomplished in the same manner as wing skin repairs outlined in paragraph 18-14. Stringers, formed skin flanges, bulkhead channels and similar parts may be repaired as shown in figure 18-5.

18-58. DAMAGE NECESSITATING REPLACEMENT OF PARTS. Fuselage skin major repairs may be accomplished in the same manner as the wing repairs outlined in paragraph 18-15. Damaged fittings must be replaced. Seat rails serve as structural parts of the fuselage and must be replaced if damaged.

#### 18-58A. BONDED DOORS.

18-58B. REPAIRABLE DAMAGE. Bonded doors may be repaired by the same methods used for riveted structure. Rivets are a satisfactory substitute for bonded seams on these assemblies. The strength of the bonded seams in doors may be replaced by a single 3/32, 2117-AD rivet per running inch of bond seam. The standard repair procedures outlined in AC43.13-1 are also applicable to bonded doors.

#### 18-59. BULKHEADS.

18-60. LANDING GEAR BULKHEADS. Since these bulkheads are highly stressed members, irregularly formed to provide clearance for control cables, fuel lines, etc., the patch-type repairs will be, for the most part, impractical. Minor damage, consisting of small nicks or scratches, may be repaired by dressing out the damaged area, or by replacement of rivets. Any other damage must be repaired by replacing the landing gear support assembly as an aligned unit.

18-61. REPAIR AFTER HARD LANDING. Buckled skin or floorboards, and loose or sheared rivets in the area of the main gear support will give evidence of damage to the structure from an extremely hard landing. When such evidence is present, the entire support structure must be examined, and all support forgings must be checked for cracks, using a dye penetrant and proper magnification. Bulkheads in the damaged area must be checked for alignment, and deformation of the bulkhead webs must be determined with the aid of a straightedge. Damaged support structure, buckled floorboards and skins, and damaged or questionable forgings must be replaced.

18-62. REPLACEMENT OF HI-SHEAR RIVETS. Hi-shear rivet replacement with close tolerance bolts or other commercial fasteners of equivalent strength properties is permissible. Holes must not be elongated, and the Hi-shear substitute must be a smooth push fit. Field replacement of main landing gear forgings on bulkheads may be accomplished by using:

- a. NAS464P\* Bolt, MS21042-\* Nut and AN960-\* washer in place of Hi-Shear Rivets for forgings with machined flat surface around attachment holes.
- b. NAS464P\* Bolt, ESNA 2935\* Mating Base Ring, ESNA LH 2935\* Nut for forgings (with draft angle of up to a maximum of 8°)

without machined flat surface around attachment holes.

\*Dash numbers to be determined according to the size of the holes and the grip lengths required. The bolts grip length should be chosen so that No threads remain in the bearing area.

18-63. FIREWALL DAMAGE. Firewalls may be repaired by removing the damaged material and splicing in a new section. The new portion must be lapped over the old material, sealed with Pro-Seal #700 (Coast Pro-Seal Co., Chemical Division, 2235 Beverly Blvd, Los Angeles, California), compound or equivalent, and secured with stainless steel rivets. Damaged or deformed angles and stiffeners may be repaired as shown in figure 18-12, or they may be replaced. A severely damaged firewall must be replaced as a unit.

#### 18-64. ENGINE MOUNT.

18-65. DESCRIPTION. The mount for the aircraft engine is constructed of 4130 chrome-molybdenum steel tubing. A truss structure, fastened to the firewall at four points, supports a cradle arrangement. This cradle arrangement with its supporting lugs, forms the base for rubber shock mounted engine supports.

18-66. GENERAL CONSIDERATIONS. All welding on the engine mount must be of the highest quality since the tendency of vibration is to accentuate any minor defect present and cause fatigue cracks. Engine mount members are preferably repaired by using a larger diameter replacement tube, telescoped over the stub of the original member using fishmouth and rosette type welds. However, reinforced 30-degree scarf welds in place of the fishmouth welds are considered satisfactory for engine mount repair work.

18-67. ENGINE MOUNT SUPPORT CRADLE DAMAGE. Minor damage such as a crack adjacent to an engine attaching lug may be repaired by rewelding the cradle tube and extending a gusset past the damaged area. Extensively damaged parts must be replaced.

18-68. DAMAGE INVOLVING ENGINE MOUNTING LUGS AND ENGINE MOUNT TO FUSELAGE ATTACHING FITTINGS. Engine mounting lugs and engine mount-to-fuselage attaching fittings should not be repaired but must be replaced.

18-69. BAFFLES. Baffles ordinarily require replacement if damaged for cracked. However, small plate reinforcements riveted to the baffle will often prove satisfactory both to the strength and cooling requirements of the unit.

#### 18-70. ENGINE COWLING.

18-71. REPAIR OF COWLING SKINS. If extensively damaged, complete sections of cowling must be replaced. Standard insert-type skin patches, however, may be used if repair parts are formed to fit. Small

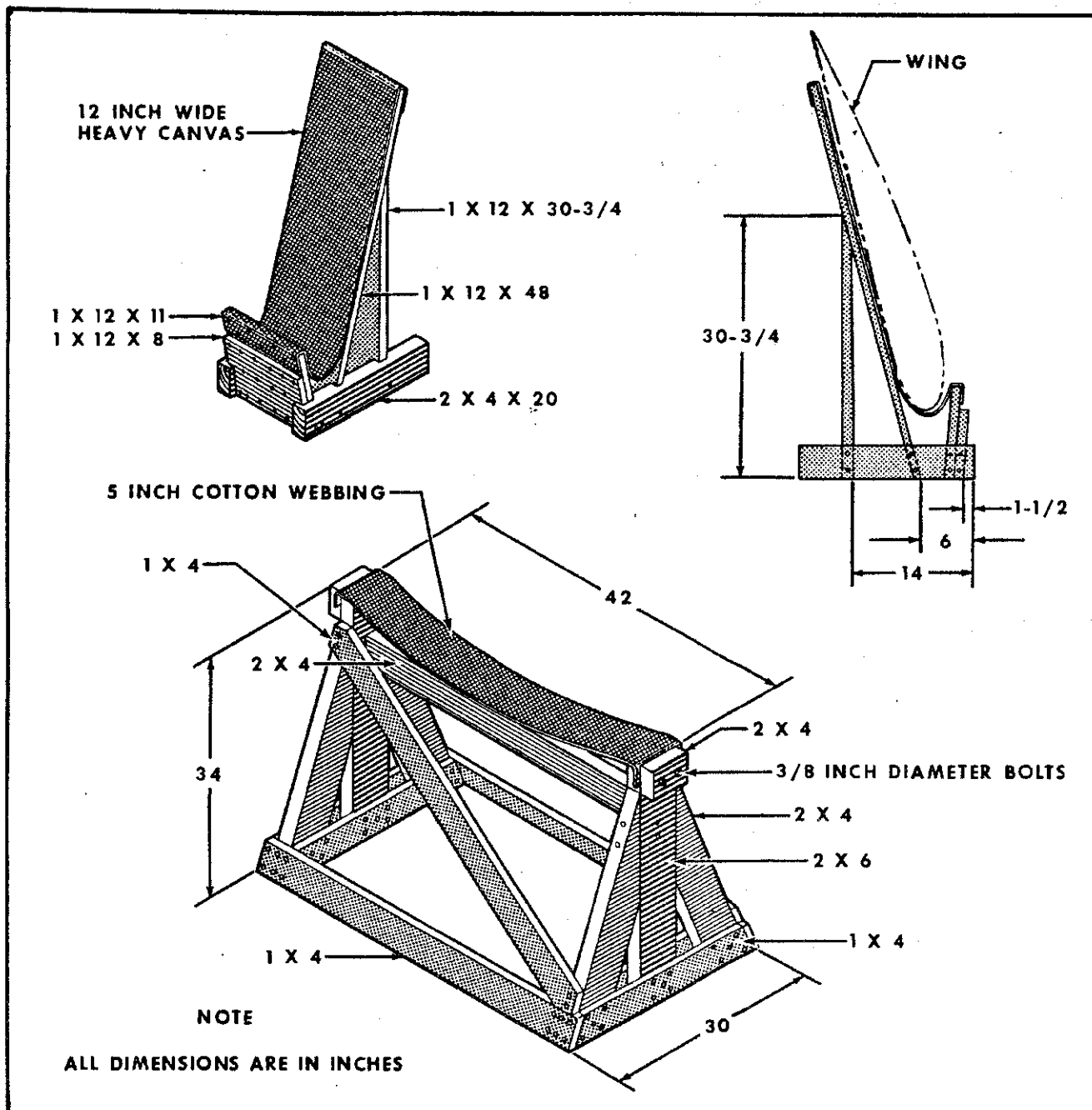

Figure 18-1. Wing and Fuselage Support Stands

cracks may be stop-drilled and dents straightened if they are reinforced on the inner side with a doubler of the same material. Bonded cowling may be repaired by the same methods used for riveted structure. Rivets are a satisfactory substitute for bonded seams on these assemblies. The strength of the bonded seams in cowling may be replaced by a single 3/32, 2117-AD rivet per running inch of bond seam. The standard repair procedures outlined in AC43.13-1 are also applicable to cowling.

18-72. REPAIR OF REINFORCEMENT ANGLES. Cowl reinforcement angles, if damaged, must be replaced. Due to their small size they are easier to replace than to repair.

18-73. REPAIR OF ABS COMPONENTS. Rezolin Repair Kit Number 404 may be obtained from the Cessna Service Parts Center for repair of ABS components.

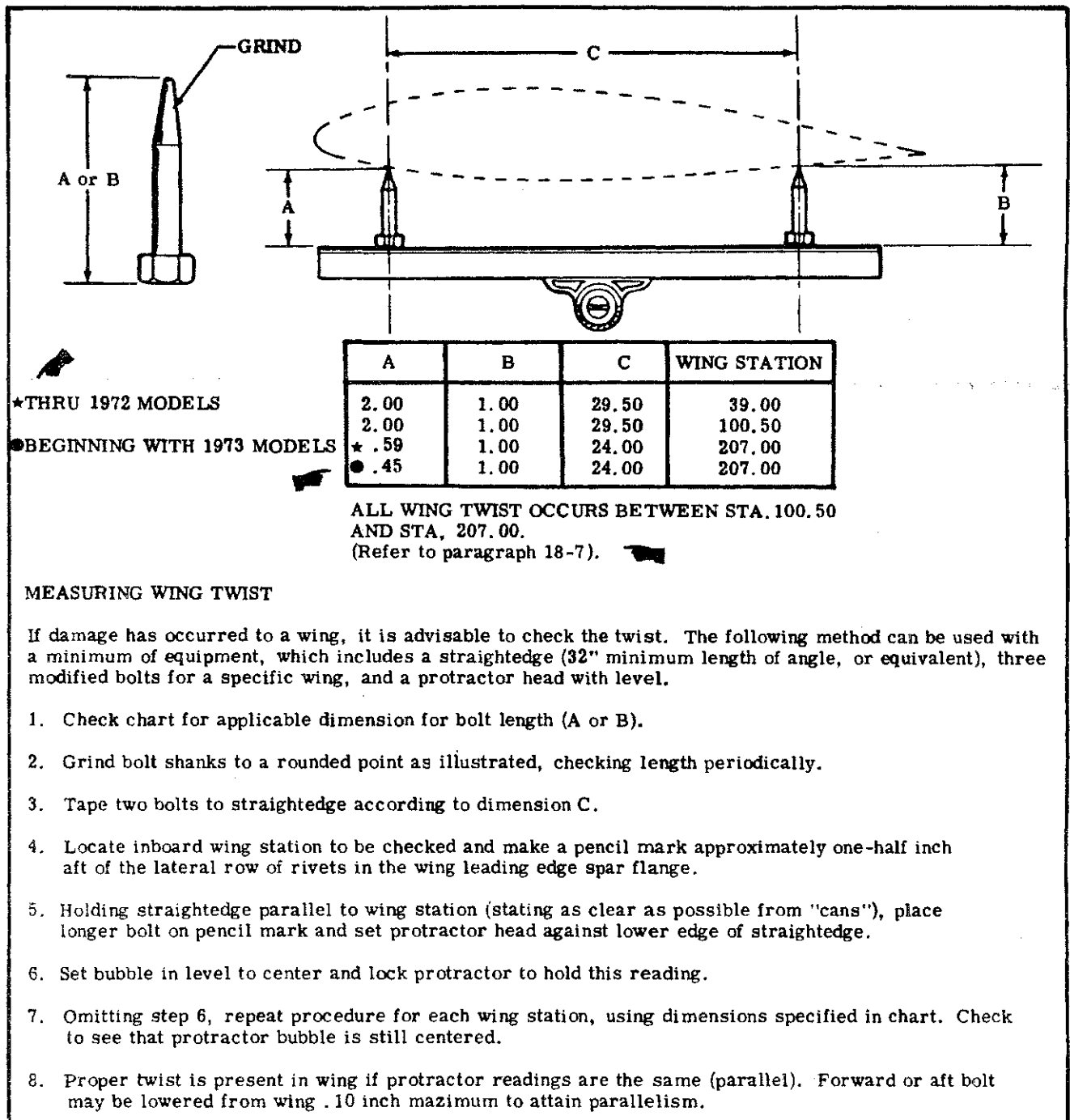

Figure 18-2. Checking Wing Twist

epoxy filler or a paste made of the plastic shavings and the solvent. Again, the crack may be reinforced with a doubler on the back side for additional strength. After the repair has been made, the area may be sanded smooth and painted. Parts that are extensively damaged require replacement instead of repair.

18-74. REPAIR OF GLASS-FIBER CONSTRUCTED

**COMPONENTS.** Glass-fiber constructed components on the aircraft may be repaired as stipulated in instructions furnished in Service Kit SK182-12. Observe the resin manufacturer's recommendations concerning mixing and application of the resin. Epoxy resins are preferable for making repairs, since epoxy compounds are usually more stable and predictable than polyester and, in addition, give better adhesion.

## BALANCING PROCEDURES

1. Balance control surfaces in an enclosed draft free area.
2. Control surface to be balanced must be in the final flight configuration, painted (if applicable) trim tabs installed, and all foreign matter removed from inside control surface.
3. If control surface is to be painted remove all existing paint prior to repainting and rebalancing. Good workmanship and standard repair practices should not result in excessive additional balance weight.
4. Place balancing mandrels (detail B) on a table or other suitable **FLAT, LEVELED** surface. Mandrels must be placed at  $90^\circ$  to the hinge line of the control surface.
5. On control surfaces with the piano type hinges, insert inboard and outboard hinges into slotted ends of the balancing mandrels, making sure that balancing mandrels are  $90^\circ$  to the hinge line. On control surfaces with the bearing type hinge point, bolts or pins are inserted through the attaching brackets, then placed on the knife edges of the mandrels as illustrated in (detail H).
6. **AILERONS.**
  - a.
    - (1) Block up the trailing edge of the aileron until a spirit-level protractor placed on the front face of the aileron spar at W. S. 154.00 ( $\pm 6.00$ ), (detail E), indicates  $57^\circ 10'$ , (detail D).
    - (2) **ALTERNATE METHOD:**  
Measure the vertical distance from the aileron hinge point to the leveled surface. Subtract 1.80 inches, then block up trailing edge of the aileron to this measurement.
  - b. With the aileron blocked in position place the balancing beam (detail A) at W. S. 154.00, ( $90^\circ$  to the hinge line), and adjust the trailing edge support on the balancing beam (detail D) until the beam is level. If the aileron has not been disturbed during this operation, the beam is now parallel to the aileron chord line at W. S. 154.00 (detail D).

### NOTE

The above procedure must be performed with care. Small angular discrepancies will produce large balancing errors.

- c. Remove balancing beam and balance the beam by itself at the knife edges by adding washers as shown, (detail C).
- d. Place the balancing beam on the aileron in its original position, then remove the blocks from beneath the trailing edge.
- e. Place the sliding weight (detail D) on the forward end of the balancing beam, moving it along the beam until the beam is again level. A small, lightweight, spirit-level may be used for this purpose provided it is symmetrical about its bubble reference and this reference is placed on the beam directly over the aileron hinge line (detail D).
- f. If aileron is correctly balanced, the position of the sliding weight with respect to the aileron hinge line, will produce a moment about the hinge line somewhere within the underbalance tolerance listed in the chart on (Sheet 5 of 5).
- g. If modification of the aileron balance weight is necessary to correct an out-of-tolerance condition, the balance weight can be lightened by drilling out part of the weight on the inboard end. The weight can be increased by a reasonable amount by ordering additional weight and gang channel listed in the applicable Parts Catalog, and installing next to the inboard weight the minimum amount necessary for correct balance. The minimum amount that must be installed, however, must contain at least two attaching rivets. If this minimum amount results in an over-balanced condition, the new weight and/or old weights can be lightened.

Figure 18-3. Control Surface Balancing (Sheet 1 of 5)

7. RUDDER AND ELEVATORS.

- a. With the rudder/elevator set upon a FLAT, LEVELED surface, block up the trailing edge until a center line through the attaching bolt and the trailing edge is equal distance from the leveling surface (detail H).
- b. Place the balancing beam (detail A) on the rudder/elevator near the center attaching bracket, (90° to the hinge line). Adjust the trailing edge support on the balancing beam (detail H) until the beam is level. If the rudder/elevator has not been disturbed during this operation, the beam is now parallel to the chord line of the rudder/elevator.

NOTE

The above procedure must be performed with care. Small angular discrepancies will produce large balancing errors.

- c. Mark position of the balancing beam, then remove and balance the beam by itself at the knife edges by adding washers as shown in (detail C).
- d. Place the balancing beam on the rudder/elevator in its original position, then remove the block from beneath the trailing edge.
- e. Place the sliding weight (detail H) on the forward end of the balance beam, move it along the beam until the beam is again level. A small, lightweight, spirit-level may be used for this purpose provided it is symmetrical about its bubble reference and this reference is placed on the beam directly over the rudder/elevator hinge line (detail H).
- f. If the rudder/elevator is correctly balanced, the position of the sliding weight with respect to the rudder/elevator hinge line, will produce a moment about the hinge line somewhere within the underbalance tolerance listed in the chart on (Sheet 5 of 5).
- g. If modification of the rudder/elevator balance weight is necessary to correct an out-of-balance condition, the balance weight can be lightened by drilling out part of the weight. The weight can be increased by fusing bar stock solder to the weight after removal from rudder/elevator.

BALANCING BEAM

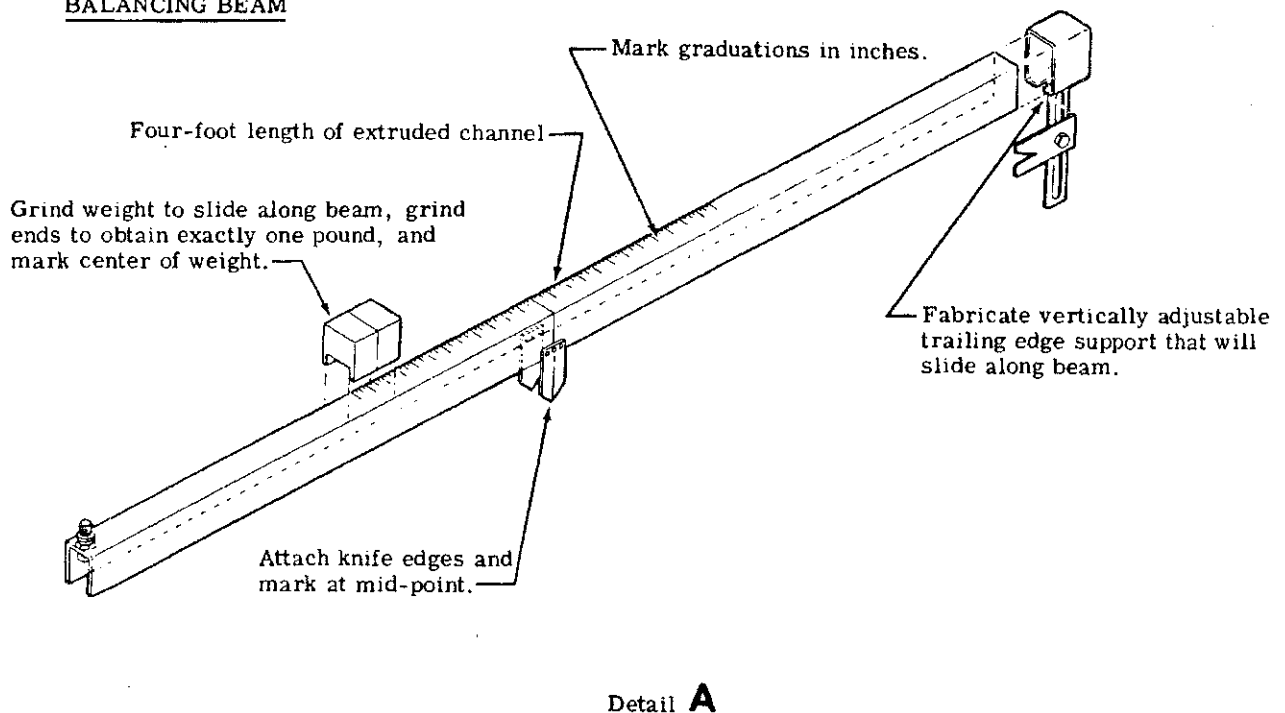

Figure 18-3. Control Surface Balancing (Sheet 2 of 5)

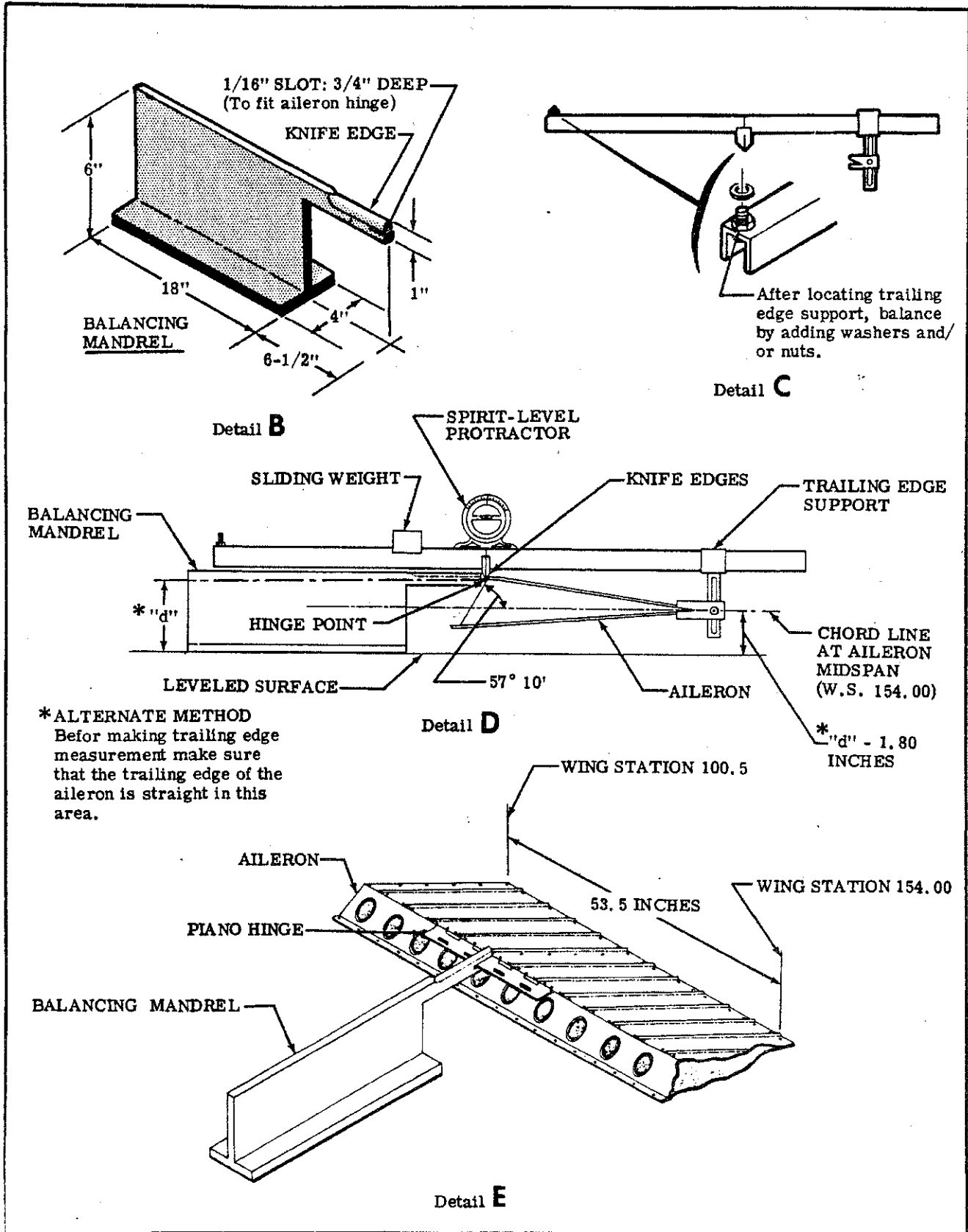

Figure 18-3. Control Surface Balancing (Sheet 3 of 5)

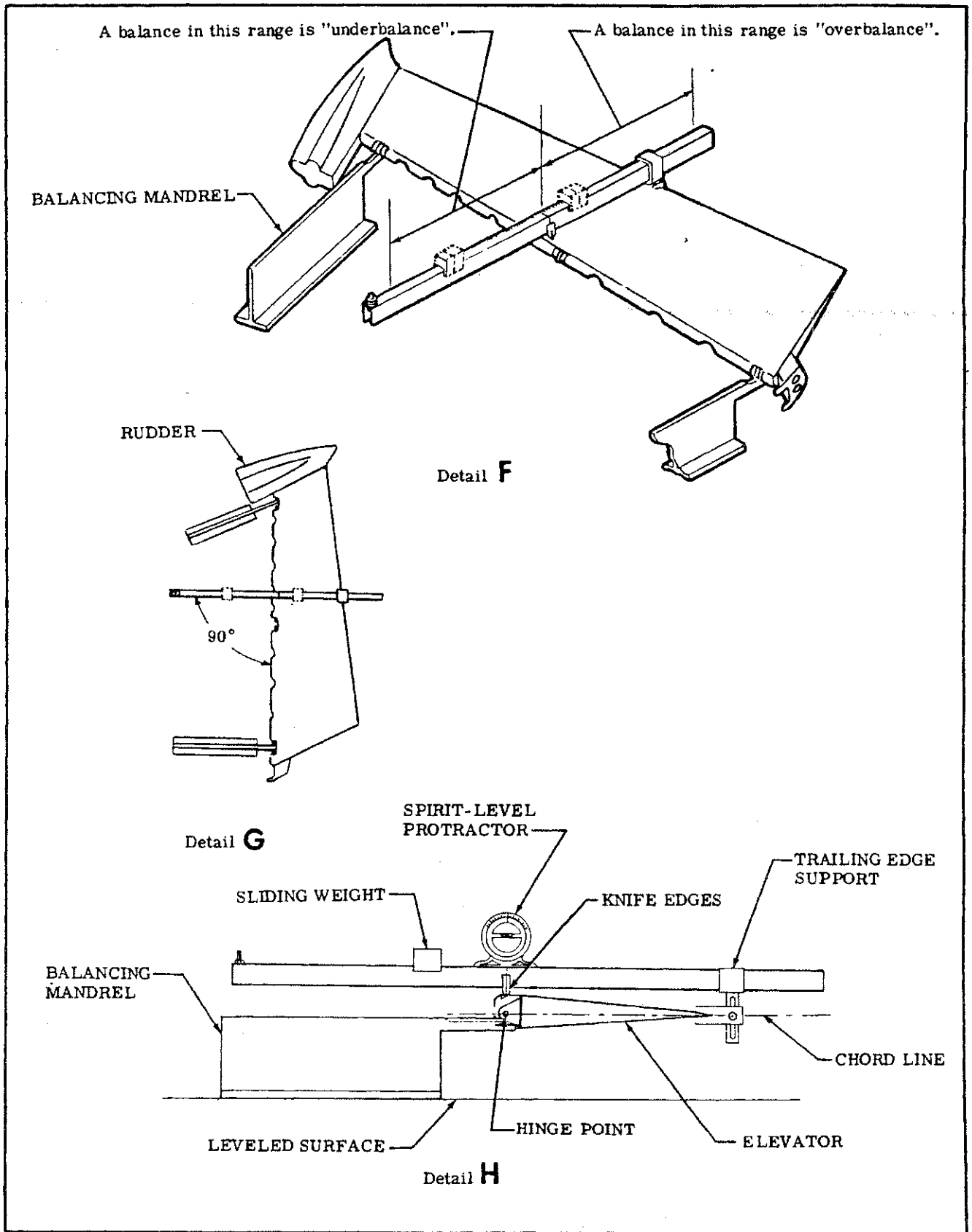

Figure 18-3. Control Surface Balancing (Sheet 4 of 5)

**CONTROL SURFACE BALANCE REQUIREMENTS**

**NOTE**

Unpainted values are not limits which must be met. They are given as guides, in order that the unbalance of the control surface in the final aircraft configuration may be predicted. If the control surface in the unpainted condition falls within the unpainted limit, the mechanic may feel confident that the control surface will be acceptable after painting. However, if the surface in the unpainted condition exceeds the unpainted limit, the balance must be checked again after final painting to assure that the control surface falls within the painted unbalance limit. Refer to **GENERAL NOTES** on sheet 3 for specific conditions.

**DEFINITIONS:**

**UNDERBALANCE** is defined as the condition that exists when the control surface is trailing edge heavy, and is symbolized by a plus (+).

**OVERBALANCE** is defined as the condition that exists when the control surface is leading edge heavy, and is symbolized by a minus (-).

**CONTROL: AILERON**

PAINTED (Inch-Pounds)	UNPAINTED (Inch-Pounds)
BALANCE LIMITS	BALANCE LIMITS
0.0 to + 11.31	0.0 to + 9.23

**CONTROL: RUDDER**

PAINTED (Inch-Pounds)	UNPAINTED (Inch-Pounds)
BALANCE LIMITS	BALANCE LIMITS
0.0 to + 6.7	0.0 to + 3.61

**CONTROL: RIGHT ELEVATOR**

PAINTED (Inch-Pounds)	UNPAINTED (Inch-Pounds)
BALANCE LIMITS	BALANCE LIMITS
0.0 to + 24.5	0.0 to + 21.5

**CONTROL: LEFT ELEVATOR**

PAINTED (Inch-Pounds)	UNPAINTED (Inch-Pounds)
BALANCE LIMITS	BALANCE LIMITS
0.0 to + 18.5	0.0 to + 15.5

Figure 18-3. Control Surface Balancing (Sheet 5 of 5)



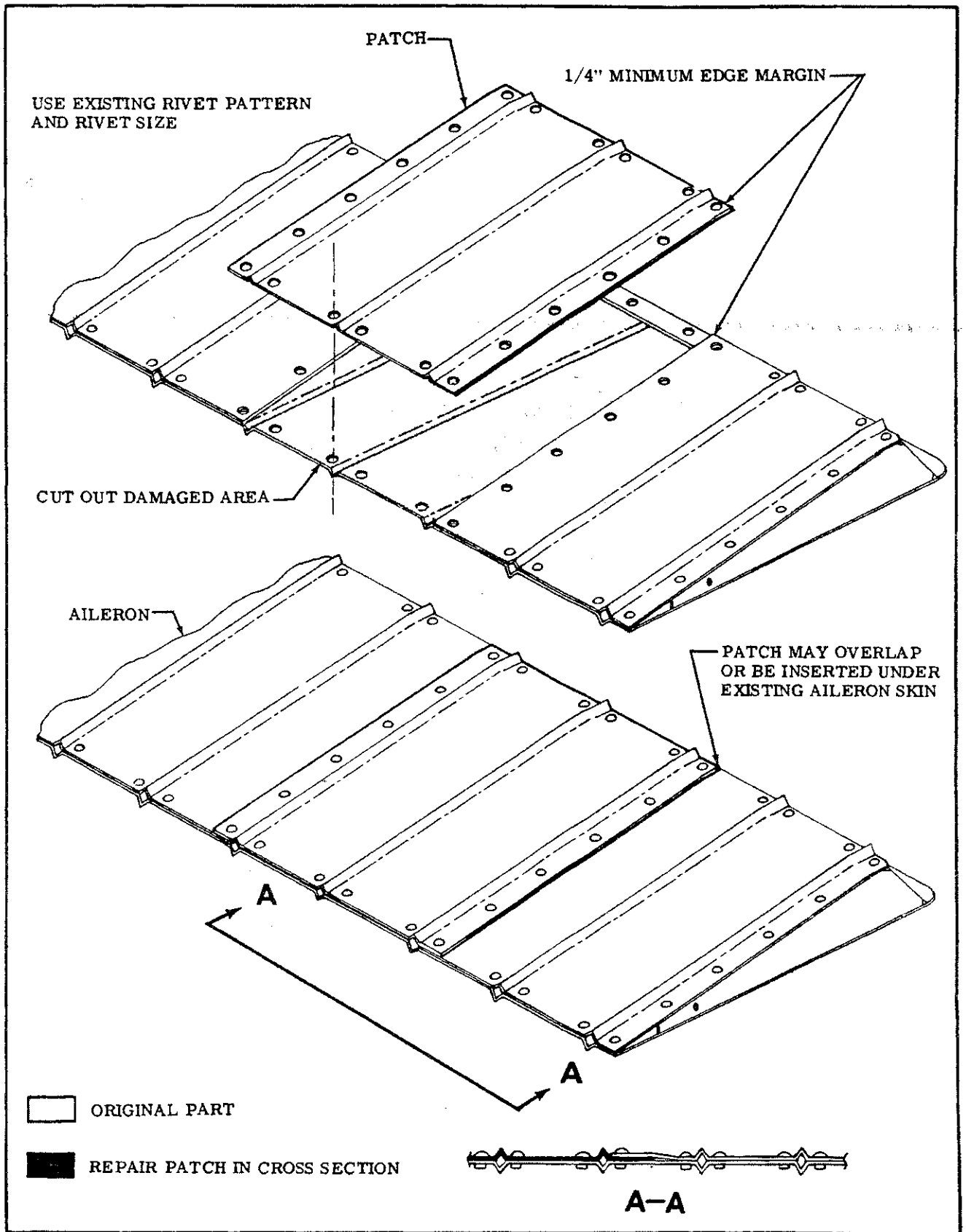
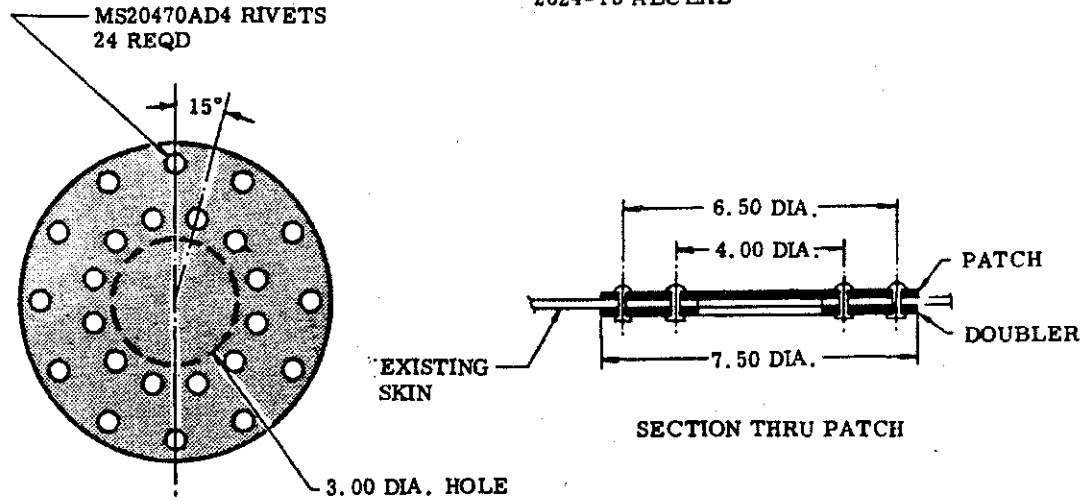
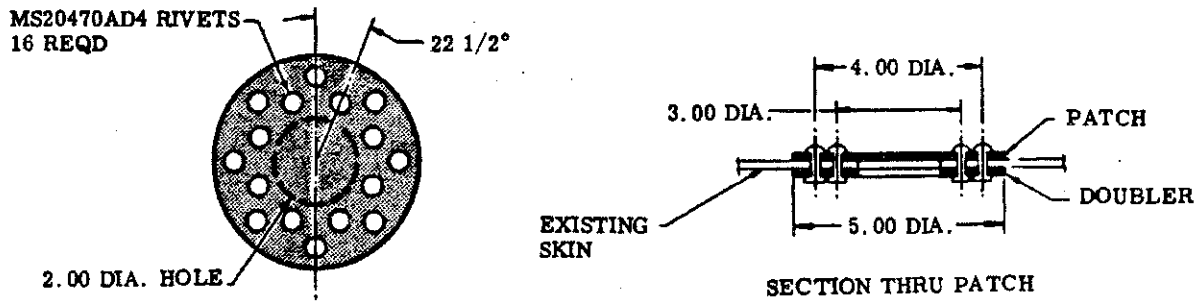

Figure 18-3A. Corrugated Skin Repair

PATCHES AND DOUBLERS —  
2024-T3 ALCLAD



PATCH REPAIR FOR 3 INCH DIAMETER HOLE



PATCH REPAIR FOR 2 INCH DIAMETER HOLE

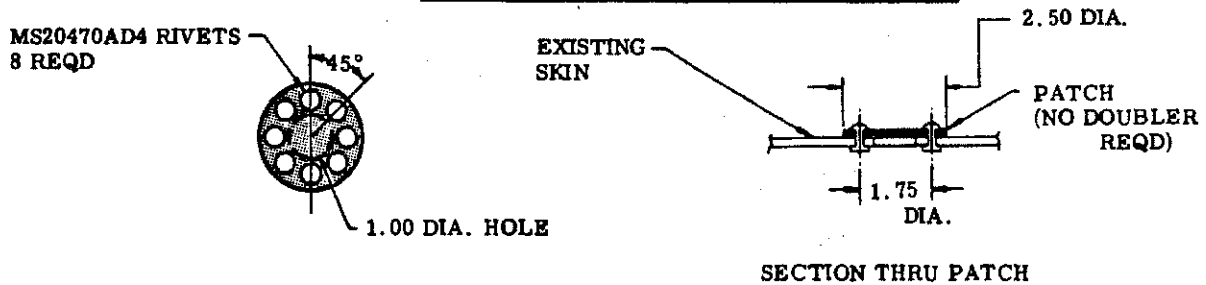

PATCH REPAIR FOR 1 INCH DIAMETER HOLE

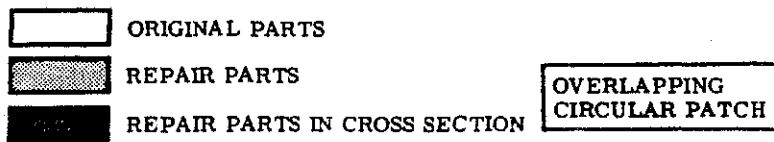

Figure 18-4. Skin Repair (Sheet 1 of 6)

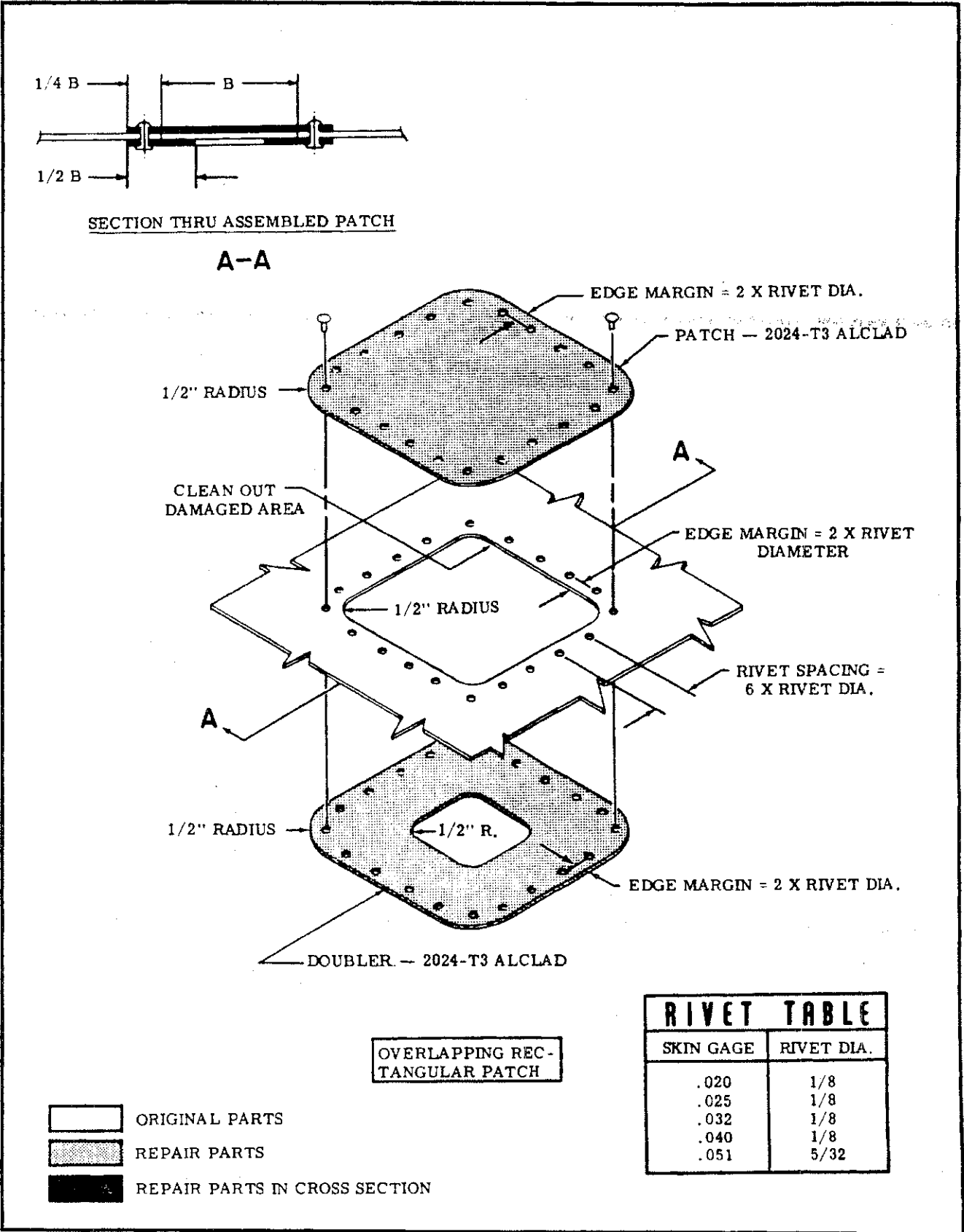
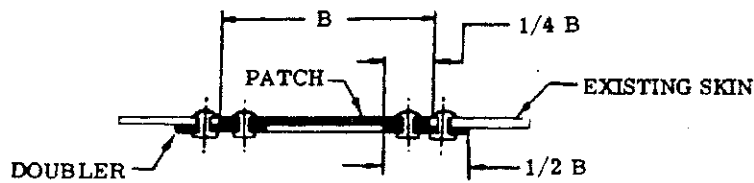

Figure 18-4. Skin Repair (Sheet 2 of 6)



SECTION THRU ASSEMBLED PATCH

NOTE

For optimum appearance and airflow, use flush rivets, dimpled skin and patch, and counter-sunk doubler.

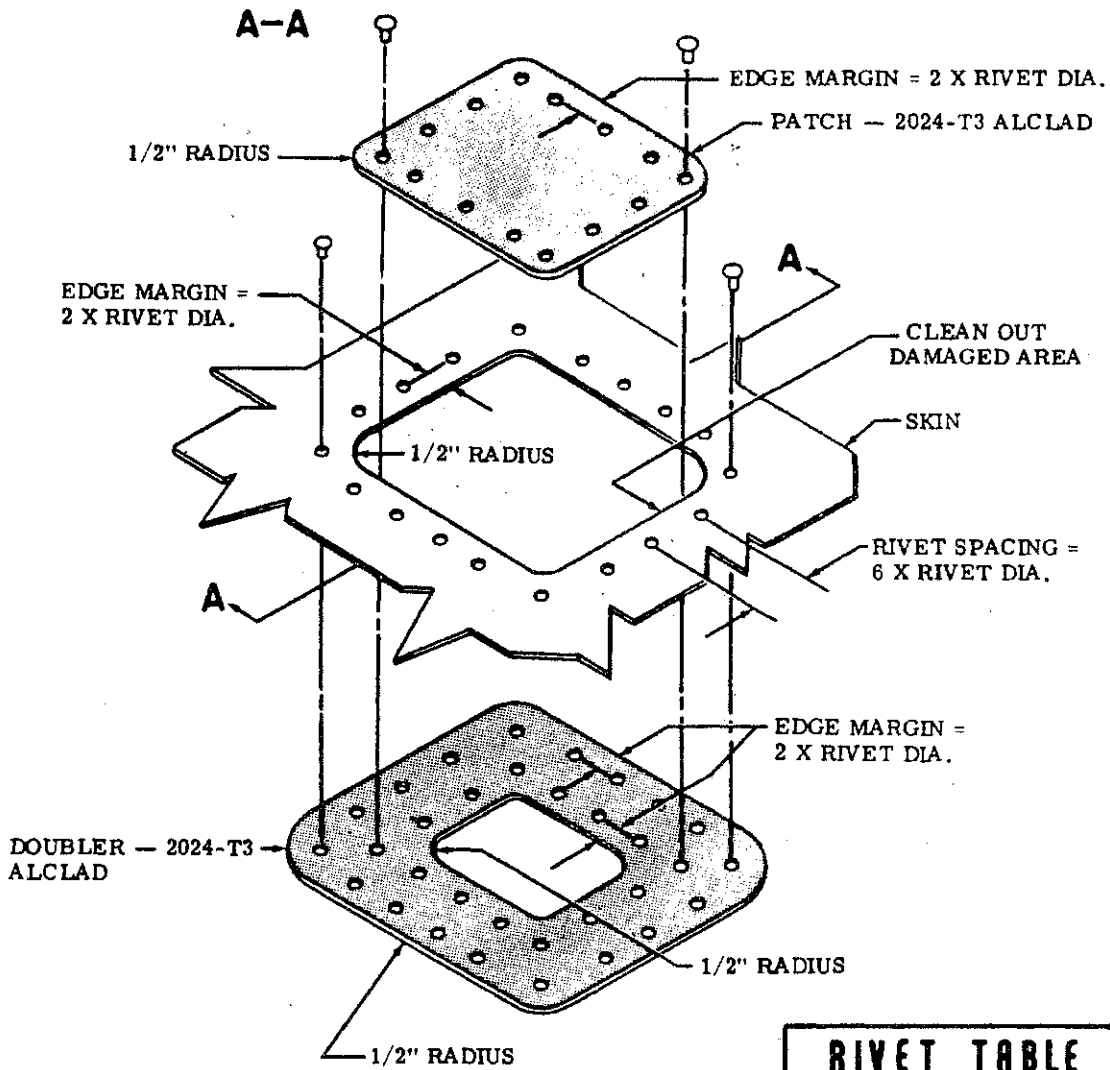

- ORIGINAL PARTS
- REPAIR PARTS
- REPAIR PARTS IN CROSS SECTION

FLUSH RECTANGULAR PATCH  
(CIRCULAR FLUSH PATCH IS  
SIMILAR)

RIVET TABLE	
SKIN GAGE	RIVET DIA.
.020	1/8
.025	1/8
.032	1/8
.040	1/8
.051	5/32

Figure 18-4. Skin Repair (Sheet 3 of 6)

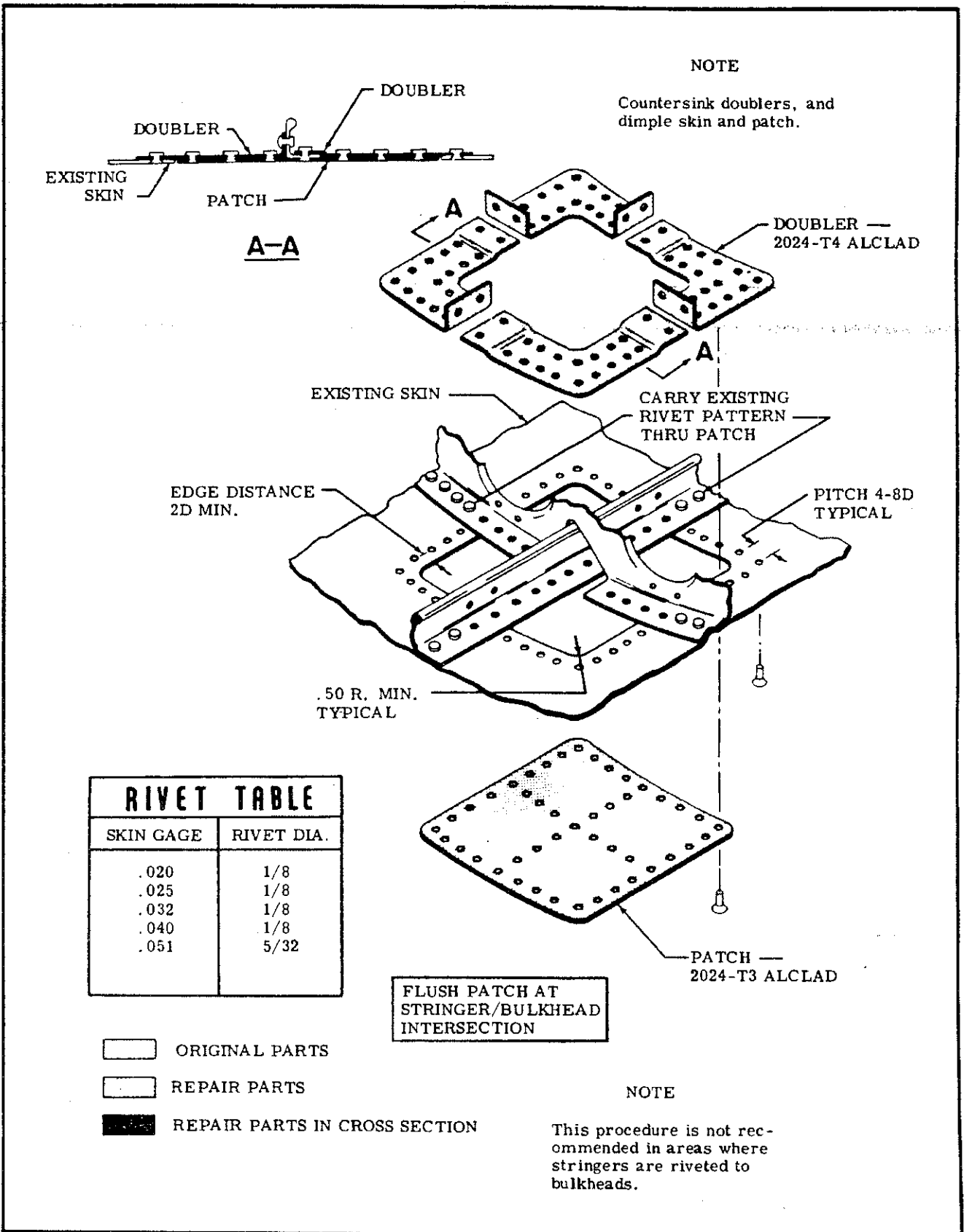

**RIVET TABLE**

SKIN GAGE	RIVET DIA.
.020	1/8
.025	1/8
.032	1/8
.040	1/8
.051	5/32

- ORIGINAL PARTS
- REPAIR PARTS
- REPAIR PARTS IN CROSS SECTION

Figure 18-4. Skin Repair (Sheet 4 of 6)

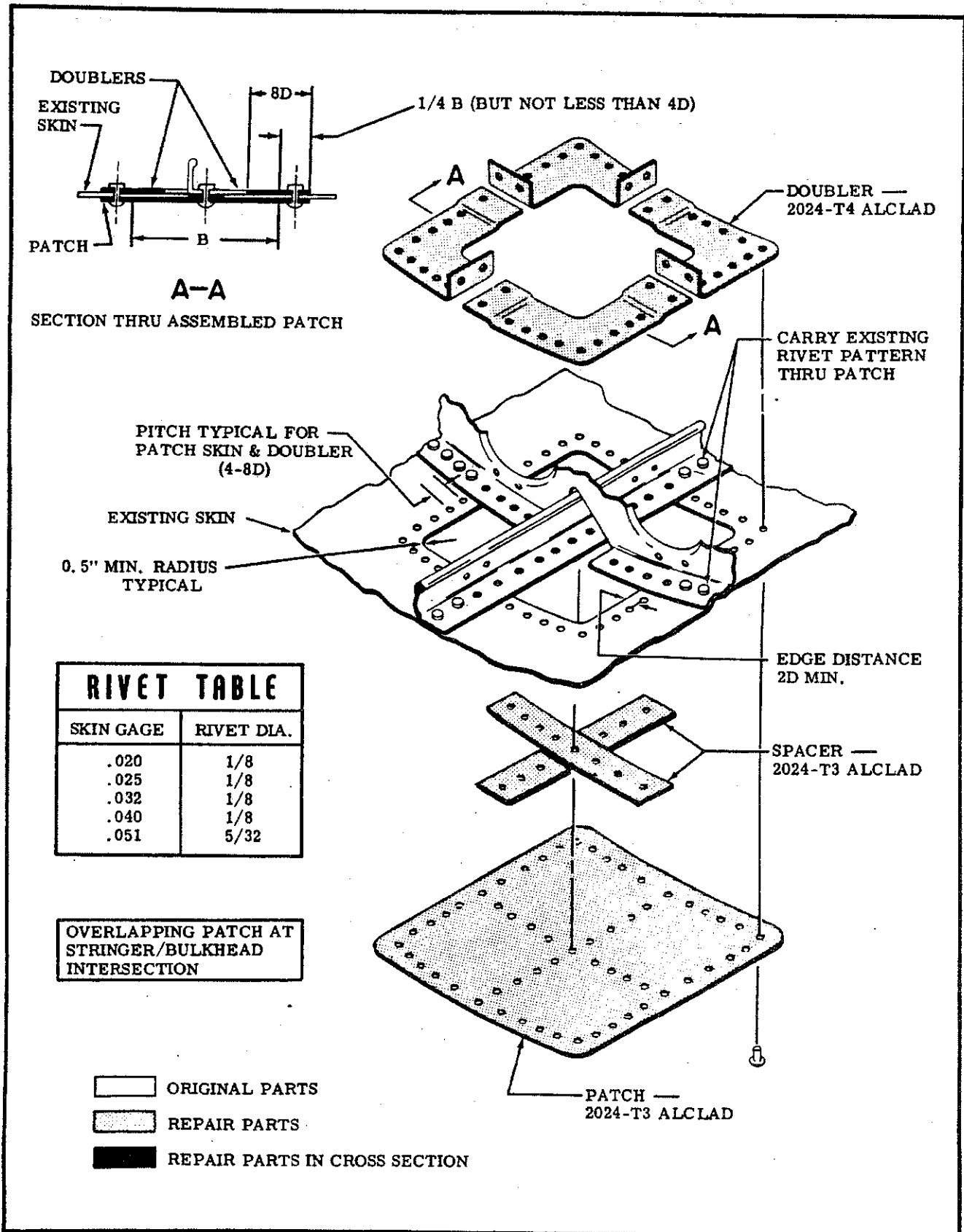

Figure 18-4. Skin Repair (Sheet 5 of 6)

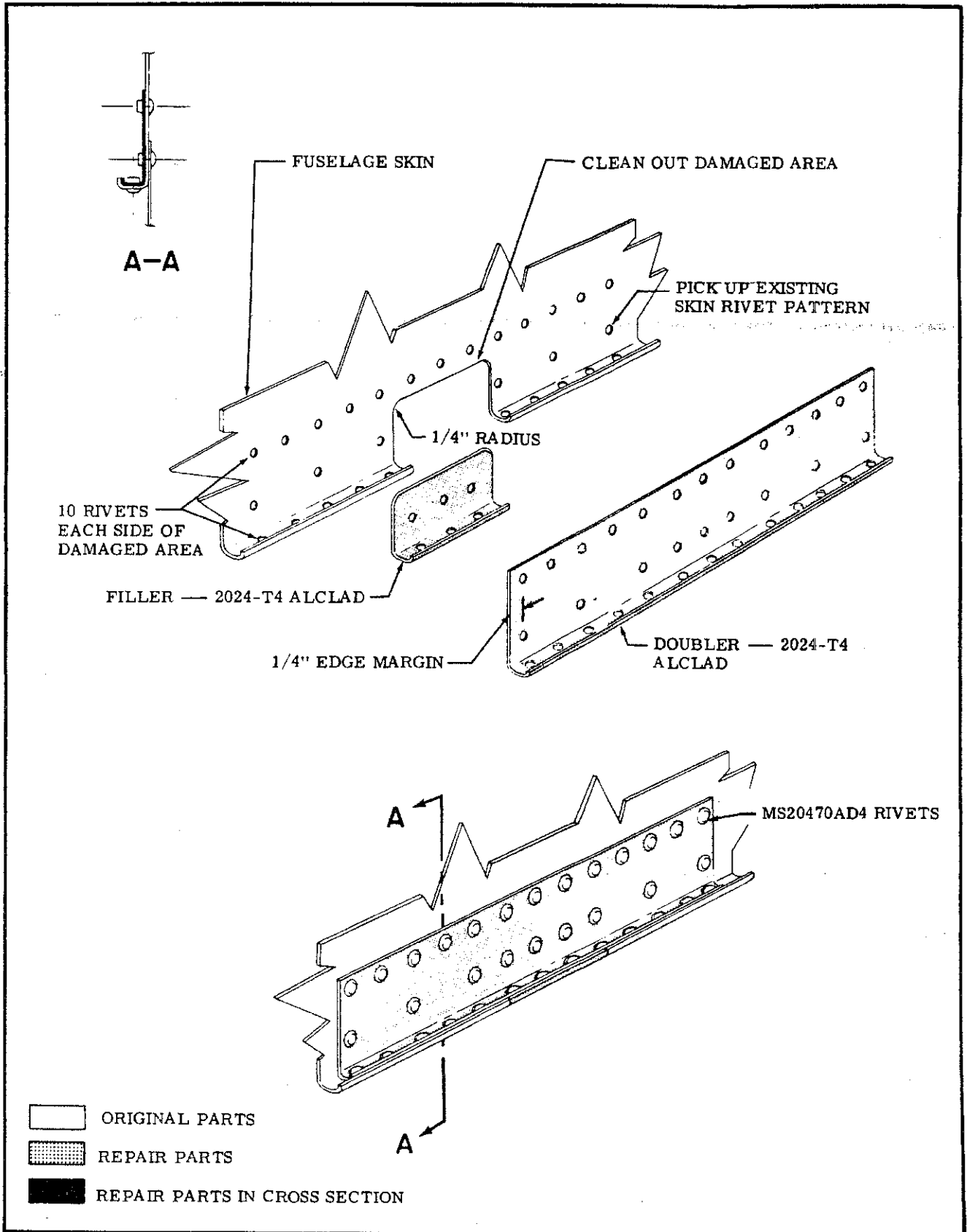

Figure 18-4. Skin Repair (Sheet 6 of 6)

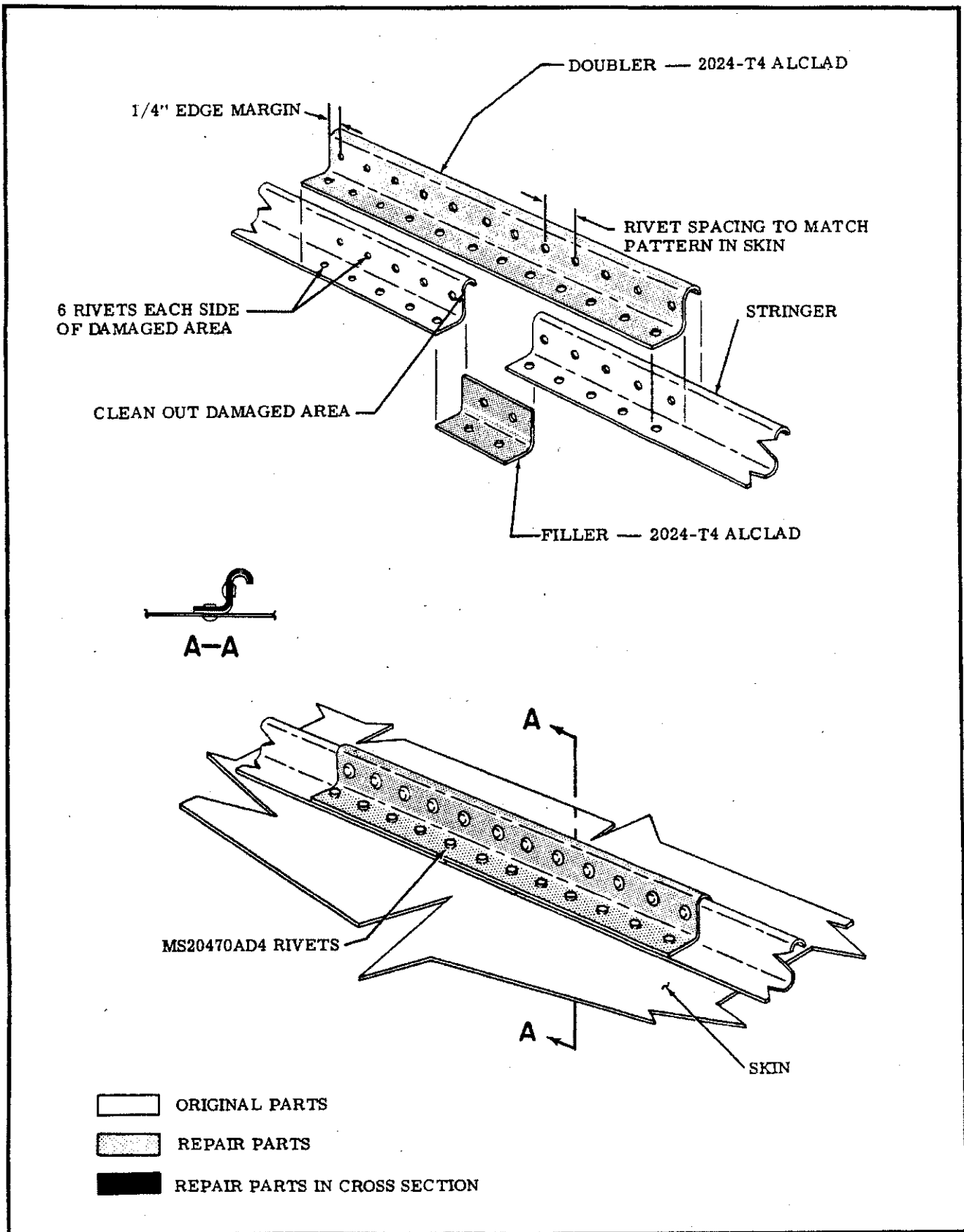

Figure 18-5. Stringer and Channel Repair (Sheet 1 of 4)



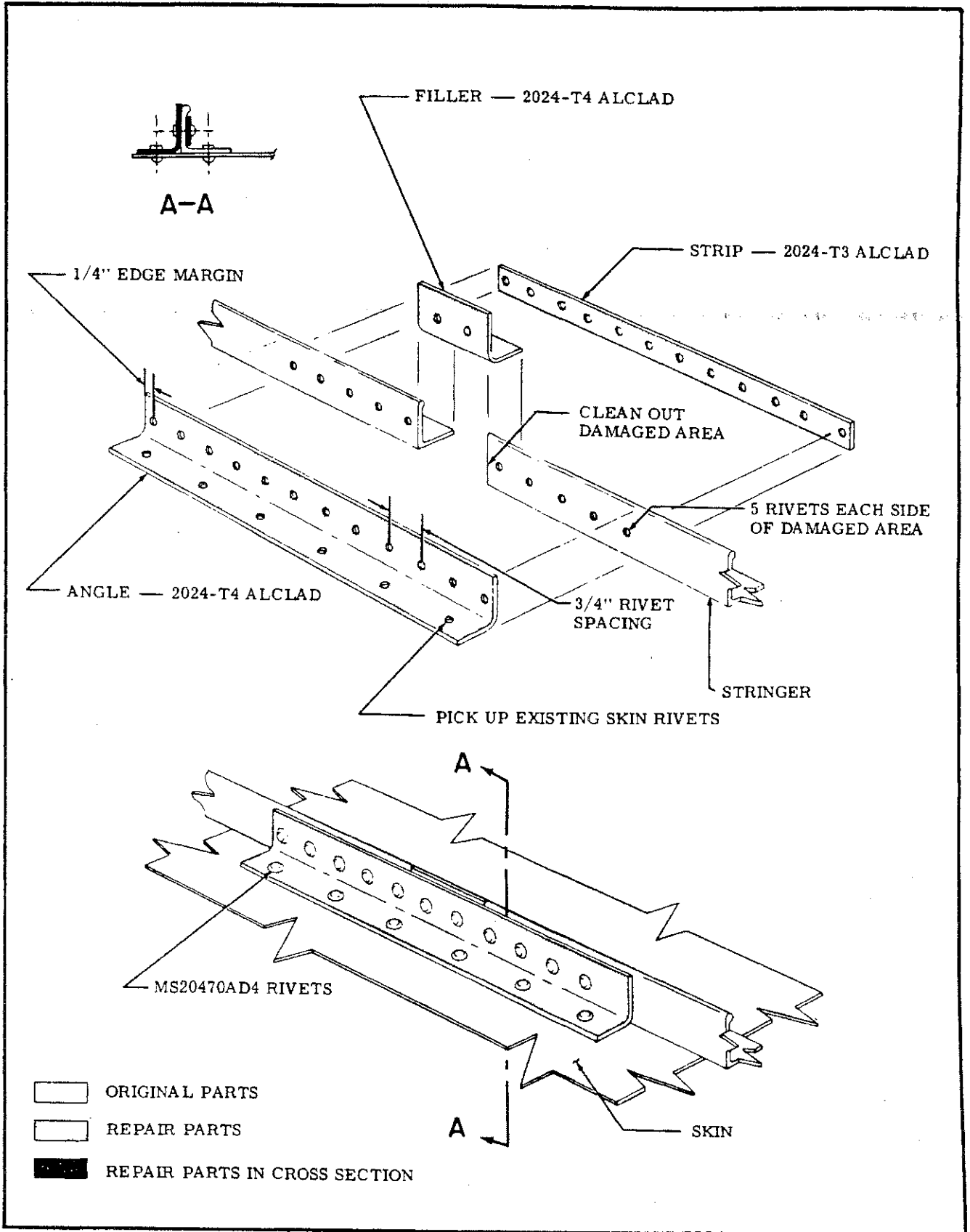

Figure 18-5. Stringer and Channel Repair (Sheet 2 of 4)

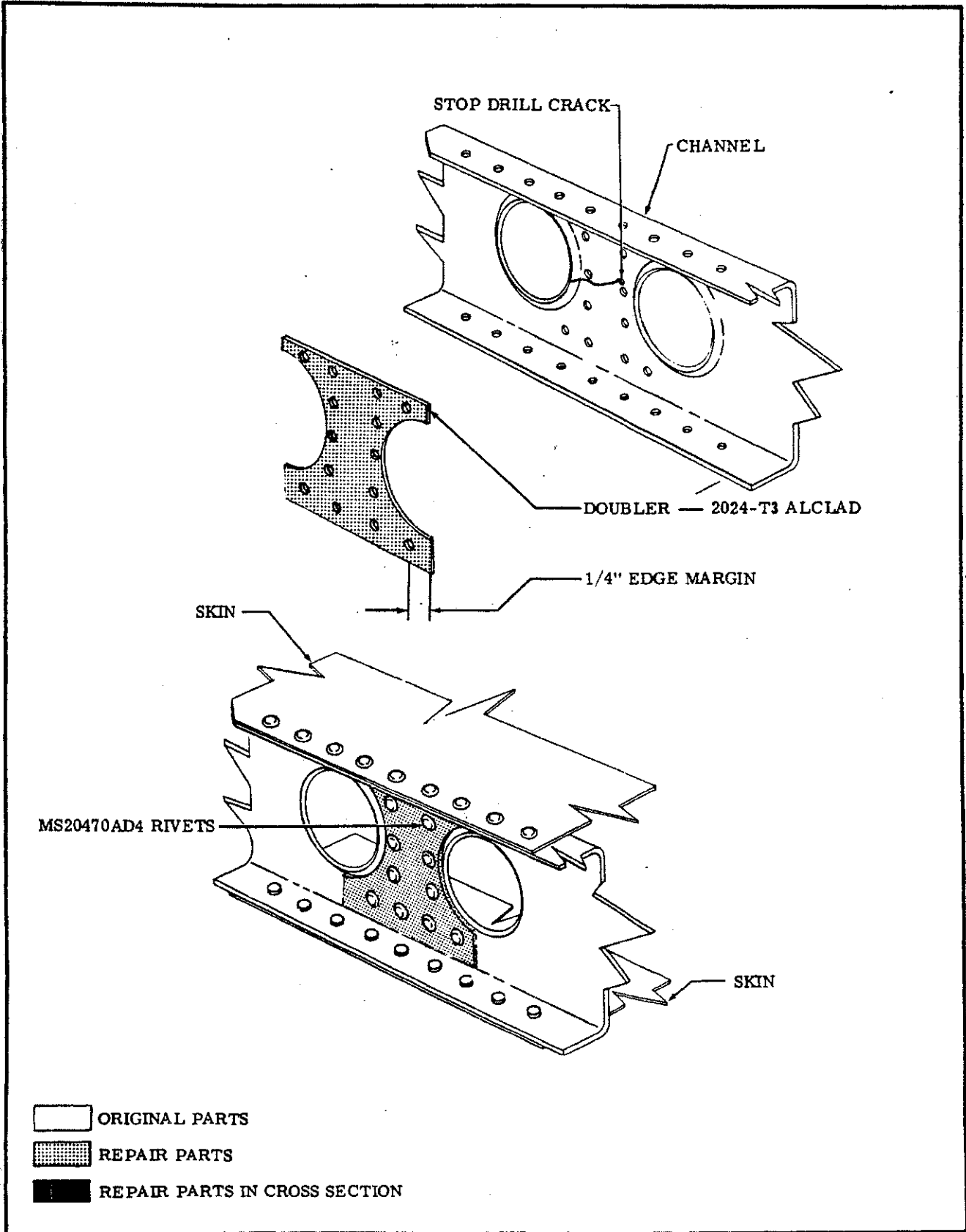

Figure 18-5. Stringer and Channel Repair (Sheet 3 of 4)

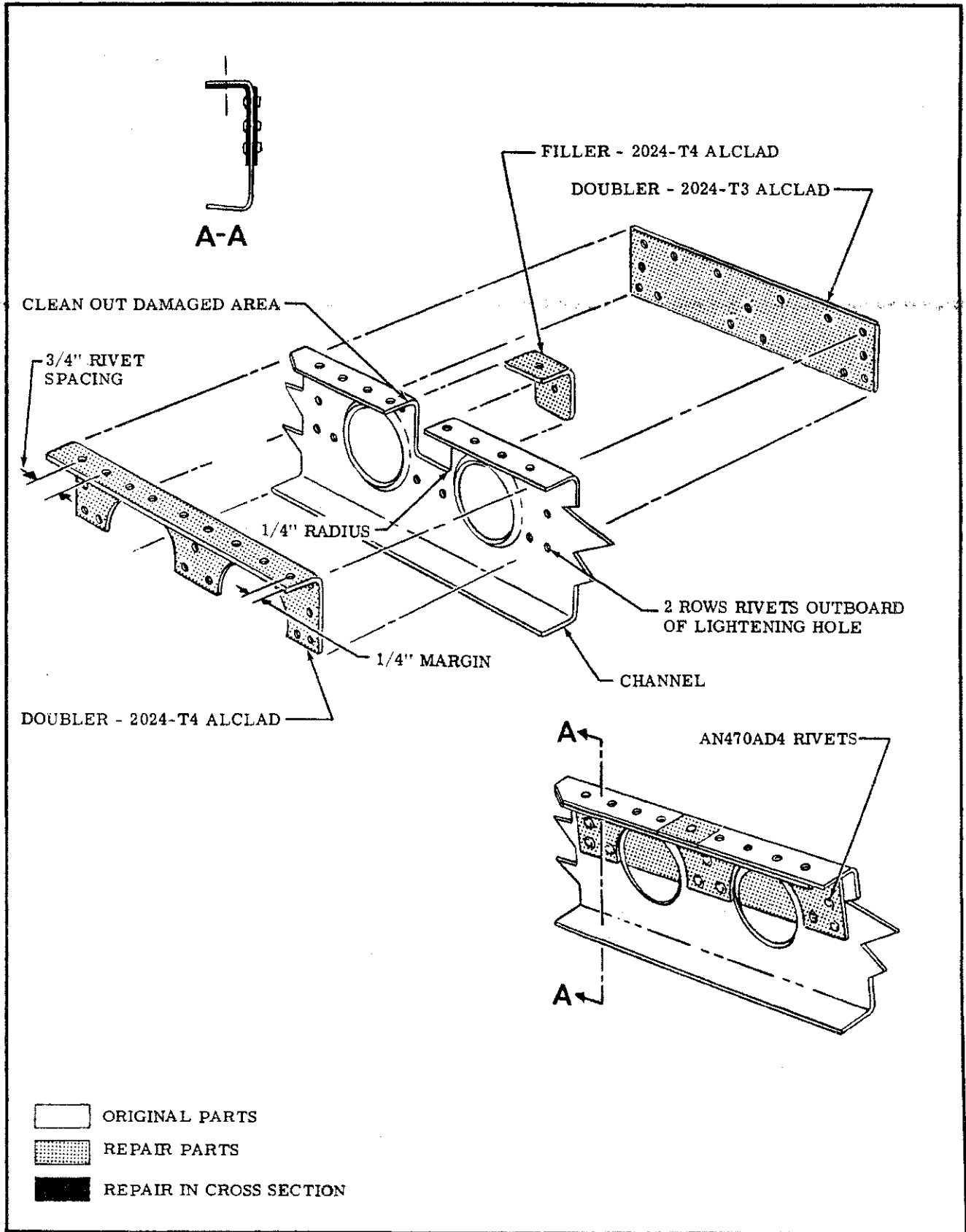

Figure 18-5. Stringer and Channel Repair (Sheet 4 of 4)

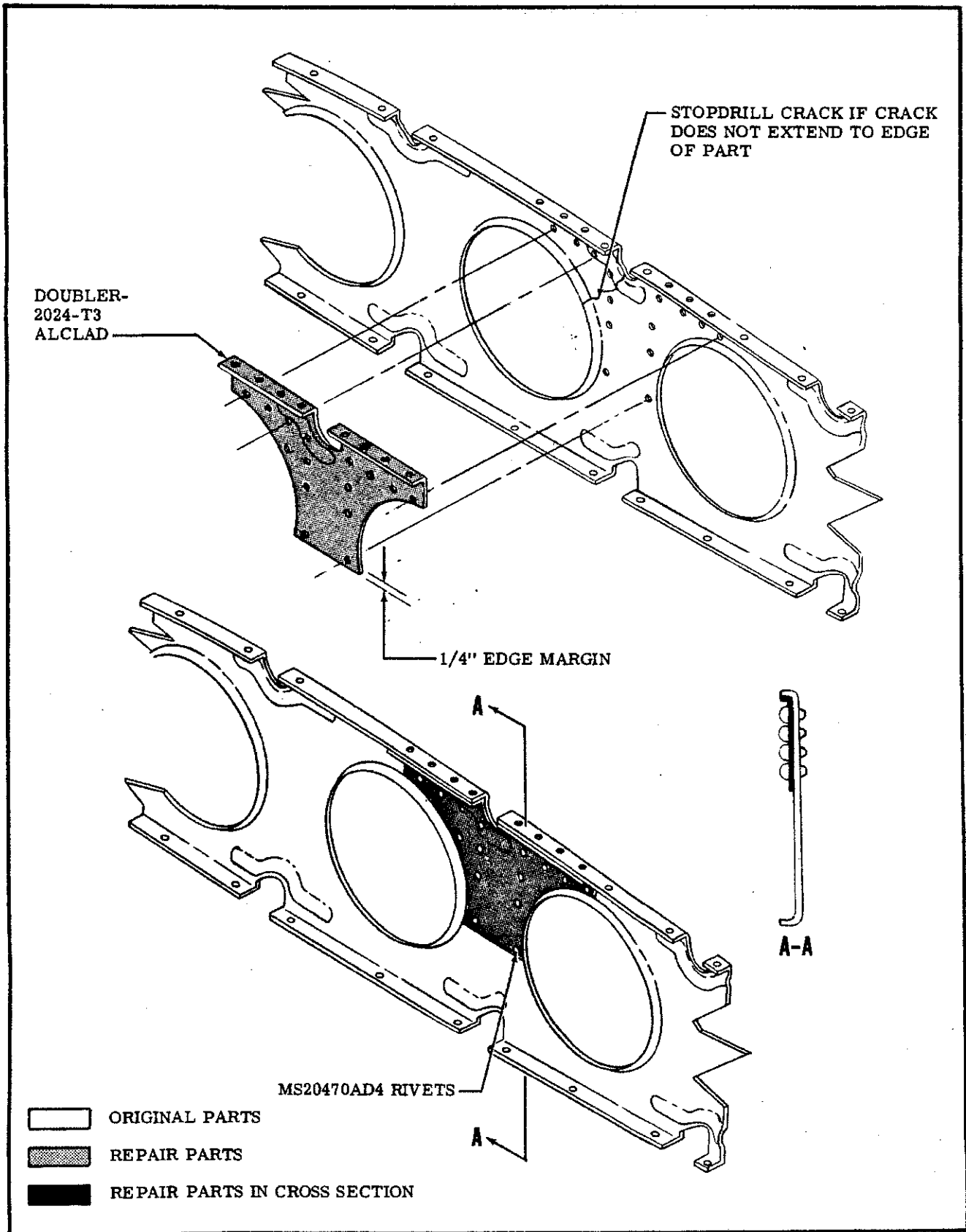

Figure 18-6. Rib Repair (Sheet 1 of 2)

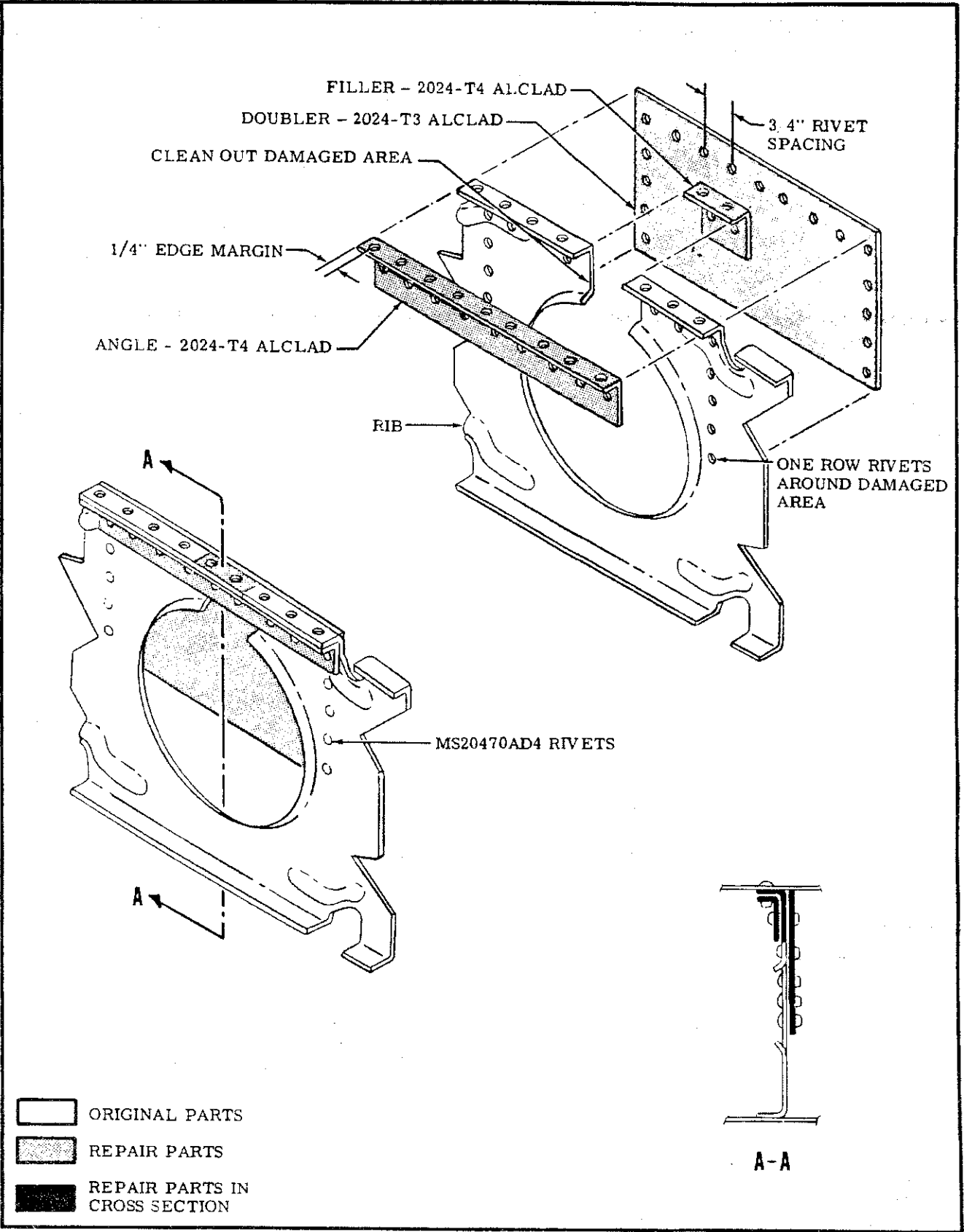

Figure 18-6. Rib Repair (Sheet 2 of 2)

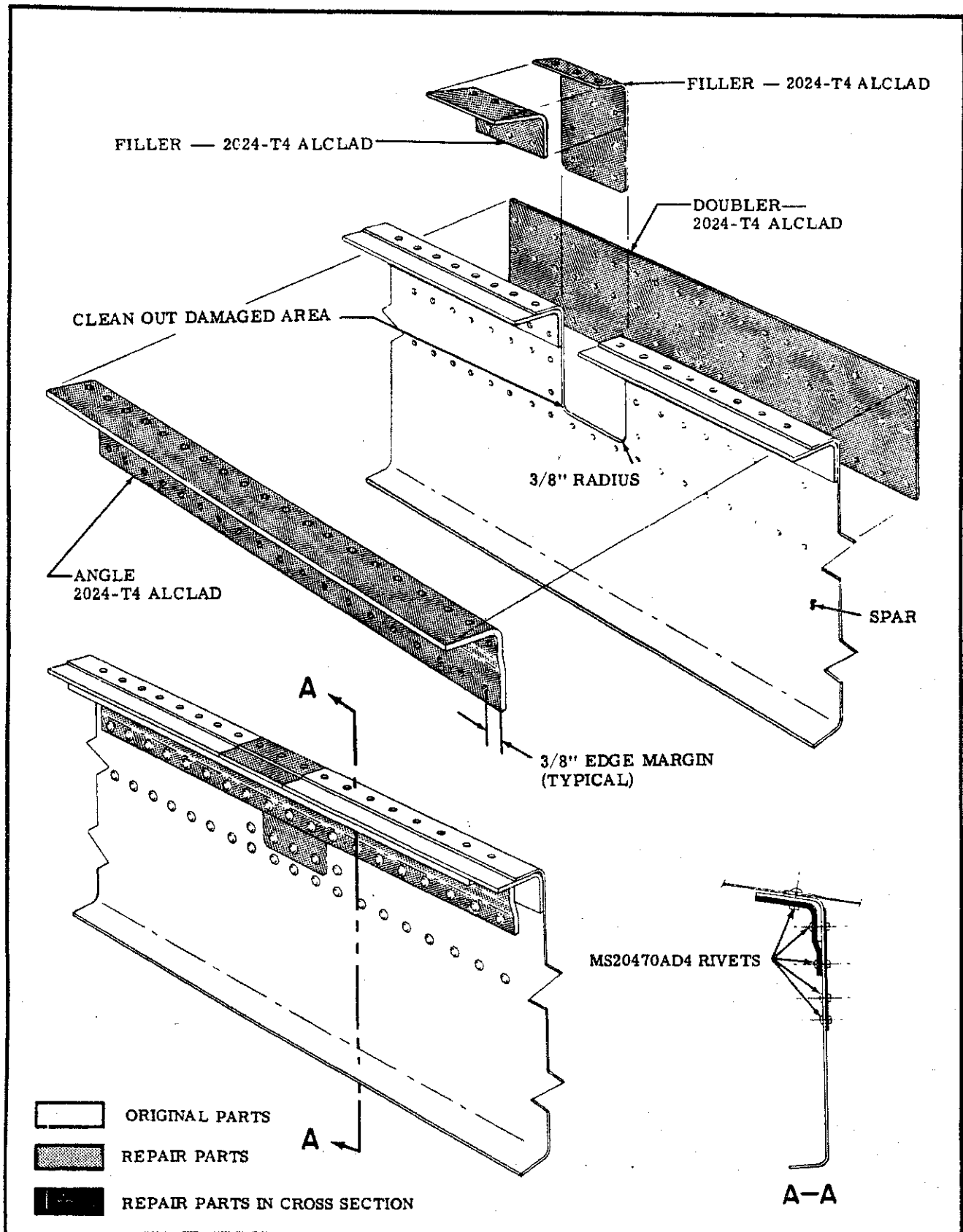

Figure 18-7. Wing Spar Repair (Sheet 1 of 3)

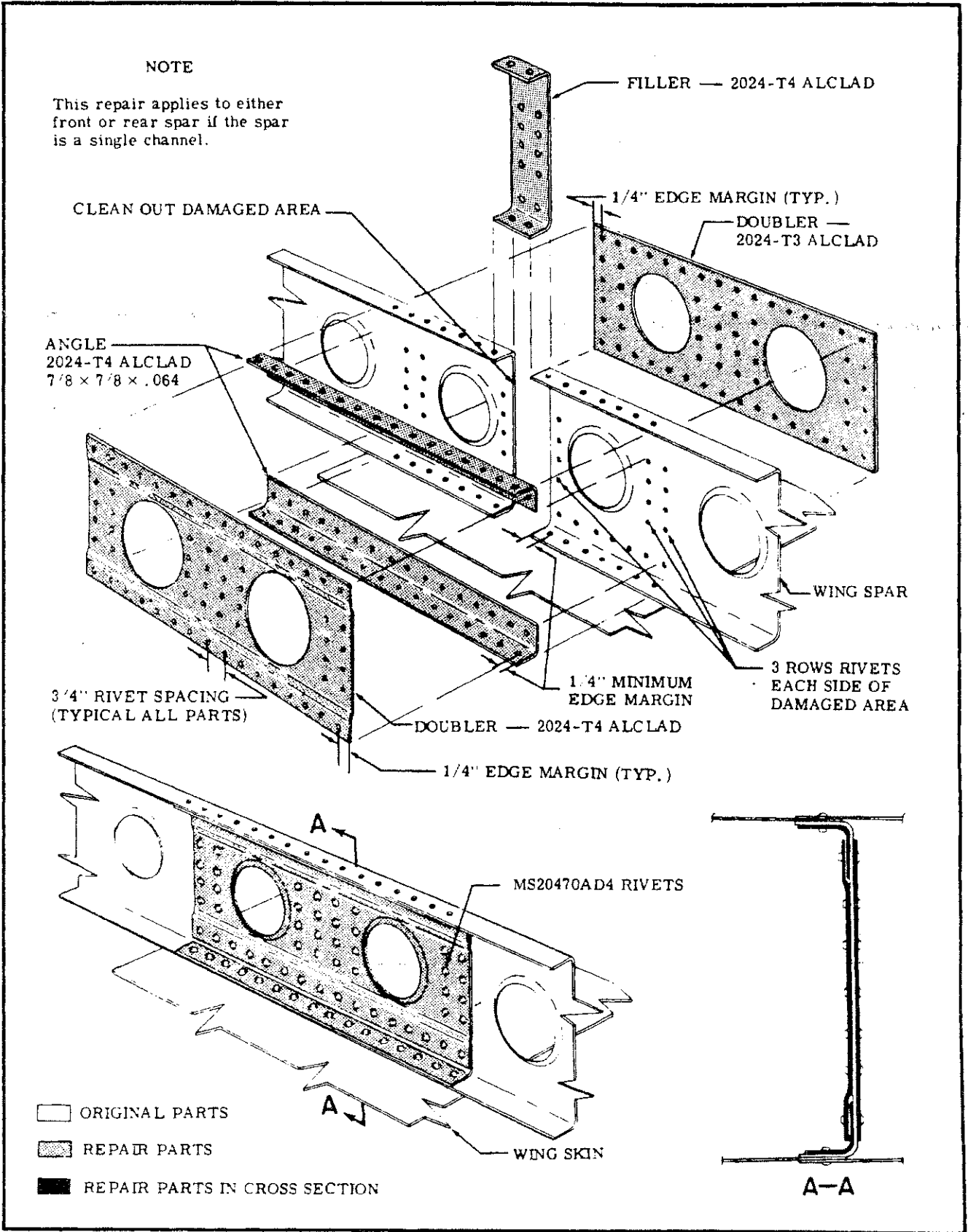

Figure 18-7. Wing Spar Repair (Sheet 2 of 3)

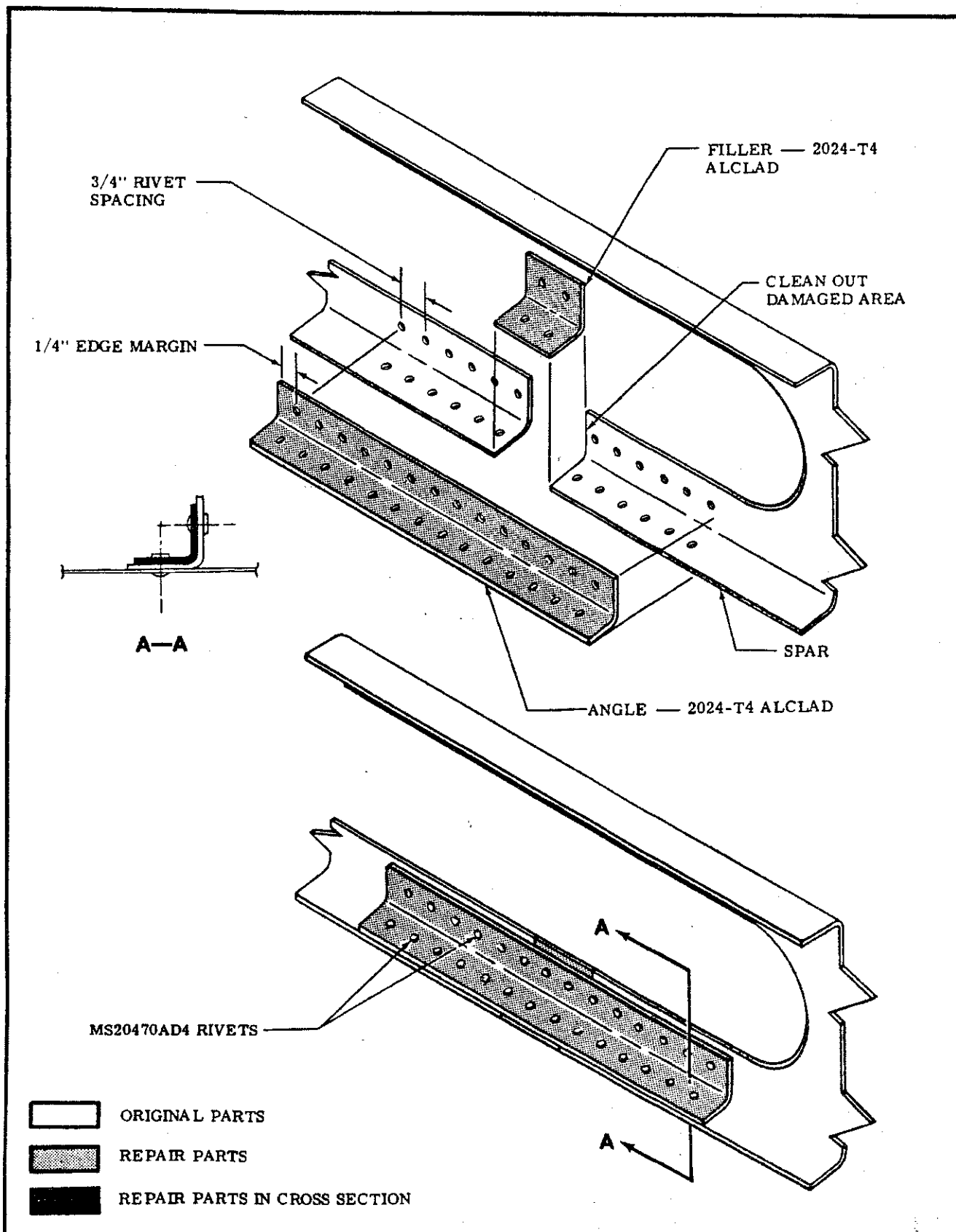

Figure 18-7. Wing Spar Repair (Sheet 3 of 3)



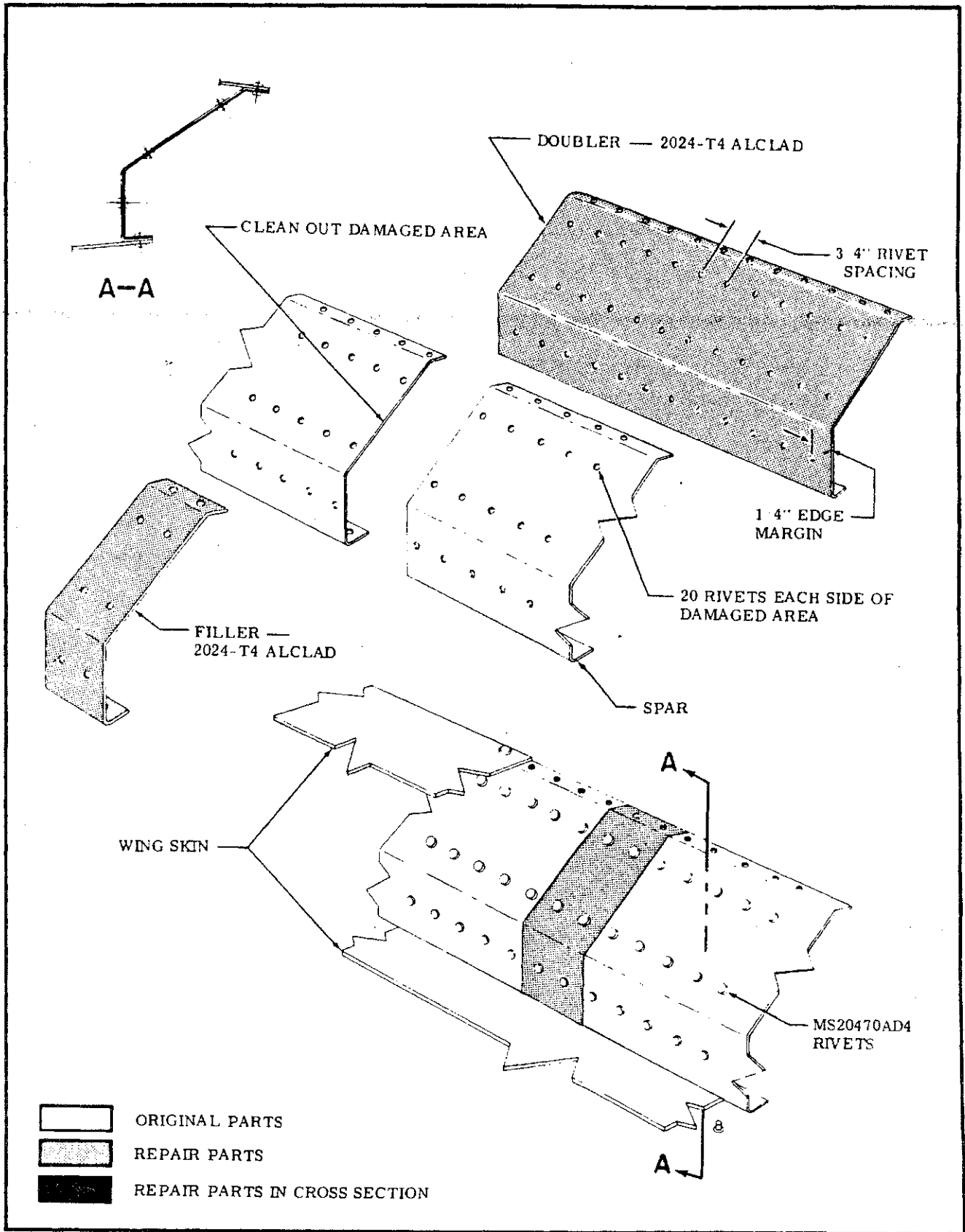

Figure 18-8. Auxiliary Spar Repair

NOTES:

1. Dimple leading edge skin and filler material; countersink the doubler.
2. Use MS20426AD4 rivets to install doubler.
3. Use MS20426AD4 rivets to install filler, except where bucking is impossible. Use CR162-4 Cherry (blind) rivets where regular rivets cannot be bucked.
4. Contour must be maintained; after repair has been completed, use epoxy filler as necessary and sand smooth before painting.
5. Vertical size is limited by ability to install doubler clear of front spar.
6. Lateral size is limited to seven inches across trimmed out area.
7. Number of repairs is limited to one in each bay.

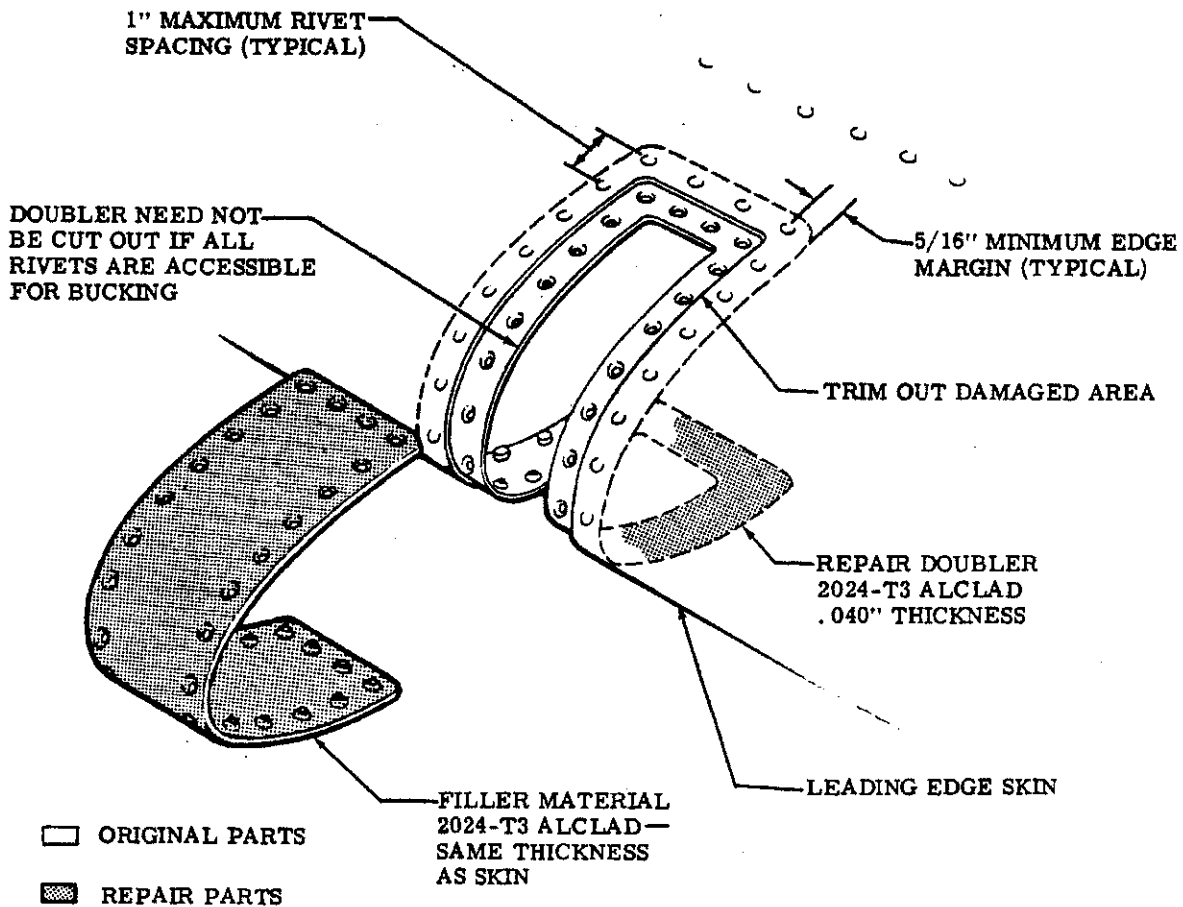

Figure 18-9. Leading Edge Repair

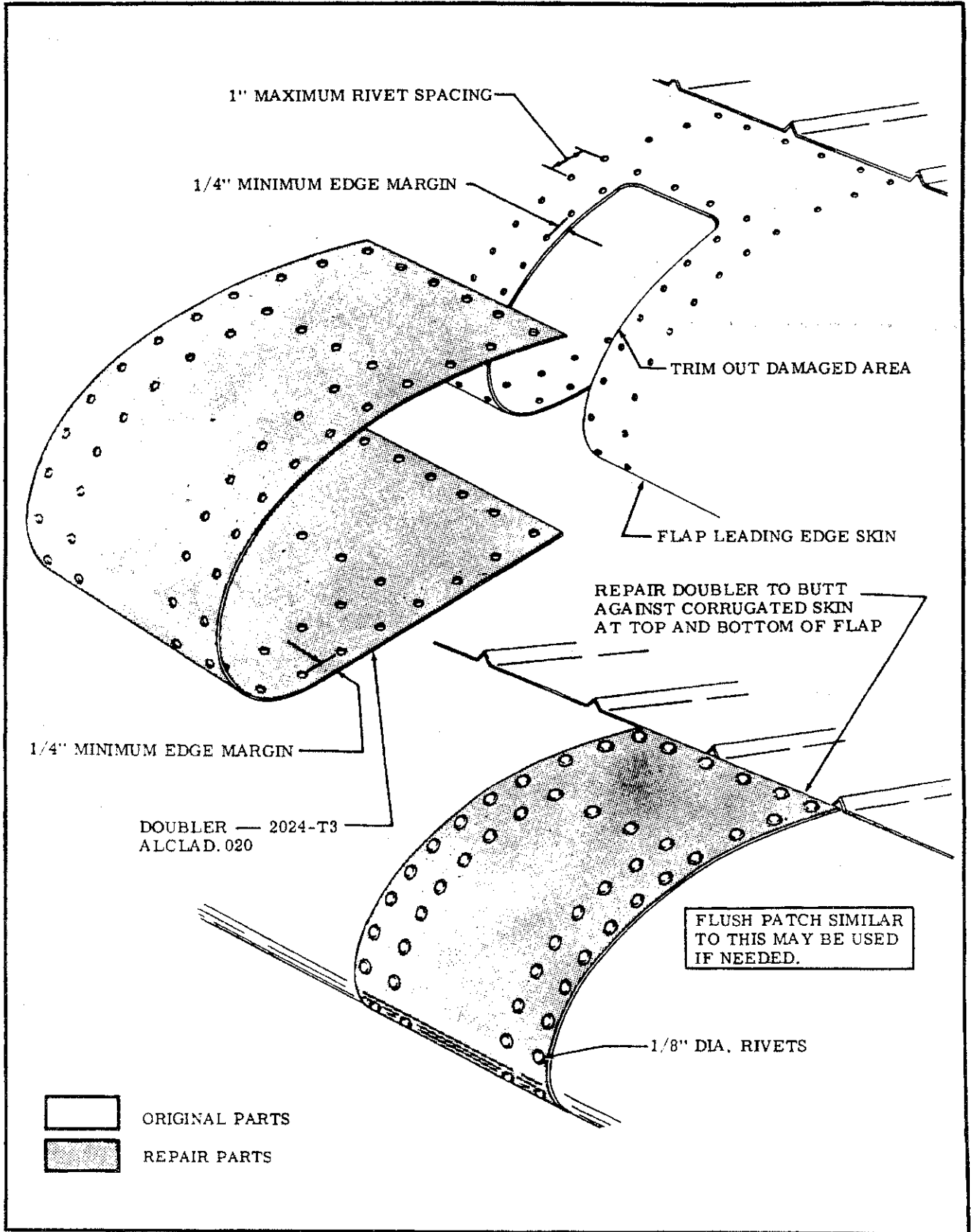
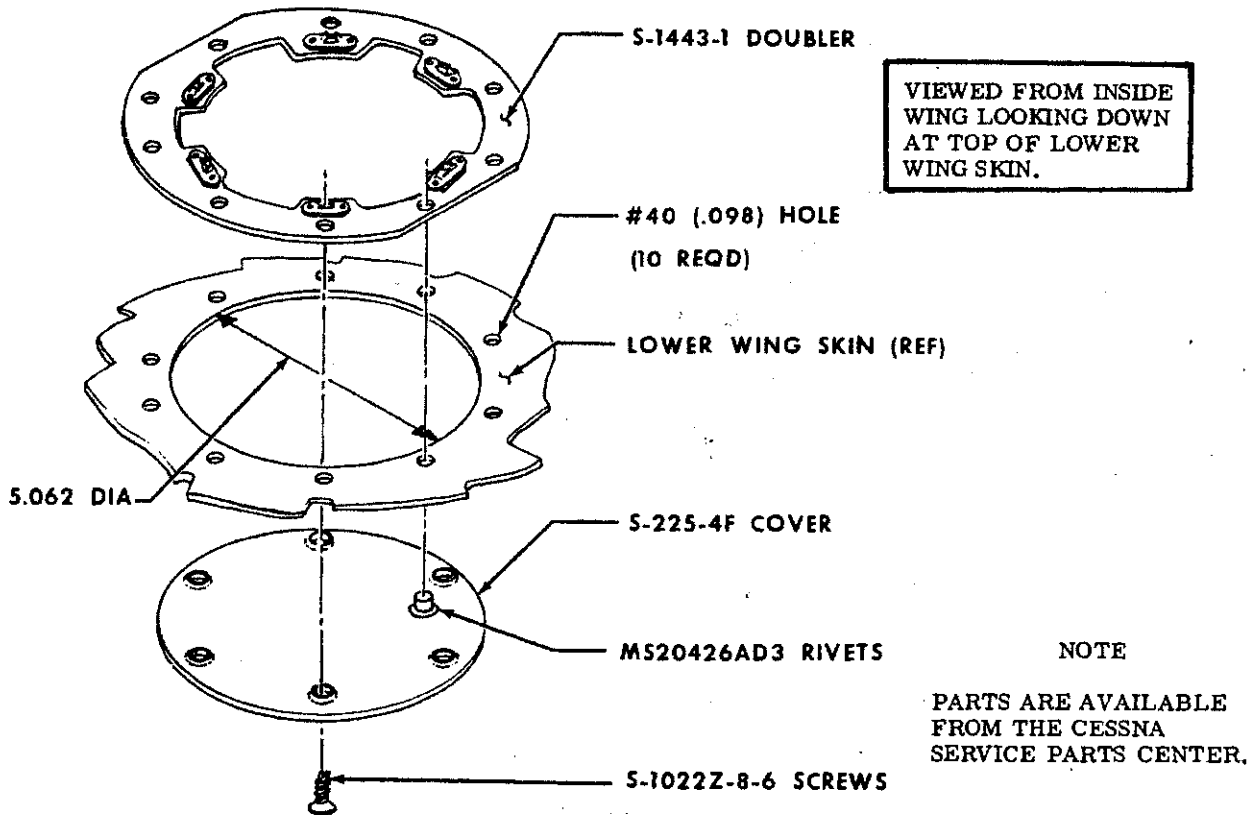

Figure 18-10. Flap Leading Edge Repair



## PRECAUTIONS

1. Add the minimum number of access holes necessary.
2. Any circular or rectangular access hole which is used with approved optional equipment installations may be added in lieu of the access hole illustrated.
3. Use landing light installations instead of access holes (thru 1970 Models) where possible. Do not add access holes at outboard end of wing; remove wing tip instead.
4. Do not add an access hole in the same bay where one is already located.
5. Locate new access holes near the center of a bay (spanwise).
6. Locate new access holes forward of the front spars as close to the front spar as practicable.
7. Locate new access holes aft of the front spar between the first and second stringers aft of the spar. When installing the doubler, rotate it so the two straight edges are closest to the stringers.
8. Alternate bays, with new access holes staggered forward and aft of the front spar, are preferable.
9. A maximum of five new access holes in each wing is permissible; if more are required, contact the Cessna Service Department.
10. When a complete leading edge skin is being replaced, the wing should be supported in such a manner so that wing alignment is maintained.

- a. Establish exact location for inspection cover and inscribe centerlines.
- b. Determine position of doubler on wing skin and center over centerlines. Mark the ten rivet hole locations and drill to size shown.
- c. Cutout access hole, using dimension shown.
- d. Flex doubler and insert through access hole, and rivet in place.
- e. Position cover and secure, using screws as shown.

Figure 18-11. Access Hole Installation

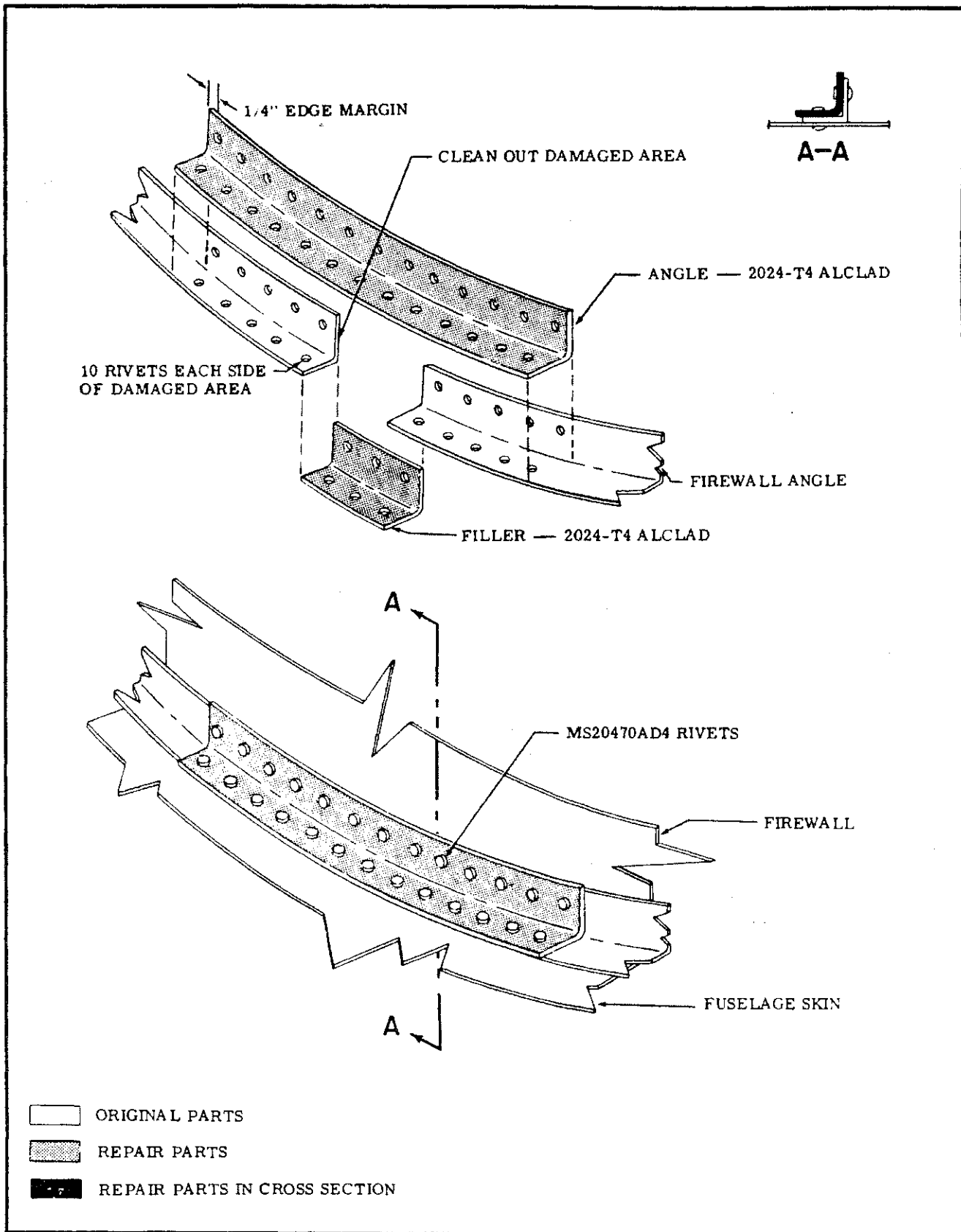

Figure 18-12. Firewall Angle Repair



NOTE

This Section contains standard factory materials listing and area of application. For paint number and color, refer to Aircraft Trim Plate and Parts Catalog. In all cases determine the type of paint on the aircraft as some types of paint are not compatible. Materials may be obtained from the Cessna Service Parts Center.

MATERIAL	NO/TYPE	172 1972	172-1969 THRU 1971 1973 THRU 1975	SKYHAWK SKYHAWK II 1969 AND ON	F172 1971	F172-1969 & 1970, 1972 THRU 1976	F SKYHAWK F SKYHAWK II 1974 AND ON	AREA OF APPLICATION
PAINT	ACRYLIC LACQUER	X	X	X	X			NOTE 1
PAINT	LACQUER	X			X	X	X	NOTE 1
PAINT	VINYL		X	X		X	X	NOTE 2
PRIMER	ER-7 WITH ER-4 ACTIVATOR	X	X	X	X	X	X	NOTE 3
PRIMER	P60G2 WITH R7K46 ACTIVATOR	X	X	X	X	X	X	NOTE 3
THINNER	T-6094A	X	X	X	X			NOTE 4
THINNER	T-8402A	X			X	X	X	NOTE 5
SOLVENT	#2 SOLVENT	X	X	X	X	X	X	NOTE 6
Refer to page 2 for notes.								

SECTION 19  
EXTERIOR PAINTING

#### NOTES

1. Used on exterior airframe.
2. Used on cabin door and window where vinyl pinch welt comes in contact with painted surface, beginning with 17267730 and F17201035.
3. Used with lacquer or acrylic on aircraft exterior.
4. Used to thin acrylic lacquer and for burndown.
5. Used to thin lacquer paint and for burndown.
6. Used to clean aircraft exterior prior to priming.

#### NOTE

Do not paint Pitot Tube, Gas Caps or Antenna covers which were not painted at the factory.

#### **CAUTION**

When stripping paint from the aircraft, avoid stripper coming in contact with ABS parts. These areas should be cleaned with soap and water and/or Naphtha. Do not use strong solvents such as Xylol, Toluol, or Lacquer Thinners. Once clean, exterior ABS parts are ready for the acrylic lacquer topcoat. Do Not wash prime ABS parts.



SECTION 20

WIRING DIAGRAMS  
THRU 1975 MODELS

TABLE OF CONTENTS

	Page		
<b>D. C. POWER</b>			
Battery Circuit . . . . .	20-2	Map and Auxiliary Instrument	
Battery Circuit . . . . .	20-3	Lights . . . . .	20-27
Starter and Ammeter . . . . .	20-4	Map and Auxiliary Instrument	
Ground Service Receptacle . . . . .	20-5	Lights . . . . .	20-28
Circuit Breaker Wiring . . . . .	20-6	Compass and Instrument	
Bus Bar, Primary, Alternator		Lights . . . . .	20-29
and Electronic . . . . .	20-7	Compass and Instrument	
Alternator System 60 Amp . . . . .	20-8	Lights . . . . .	20-31
Alternator System 60 Amp . . . . .	20-9	Dome and Courtesy Lights . . . . .	20-32
Alternator System 60 Amp . . . . .	20-10	Dome and Courtesy Lights . . . . .	20-33
Alternator System 60 Amp . . . . .	20-11	Landing and Taxi Lights . . . . .	20-34
Alternator System 60 Amp . . . . .	20-12	Landing Light . . . . .	20-35
Alternator System 60 Amp . . . . .	20-13	Landing and Taxi Lights . . . . .	20-36
Ammeter . . . . .	20-14	Landing and Taxi Lights . . . . .	20-36A
Ammeter . . . . .	20-15	Wing and Tail Lights . . . . .	20-37
<b>IGNITION</b>			
Magneto System . . . . .	20-16	Wing and Tail Lights . . . . .	20-38
Magneto System . . . . .	20-17	Flashing Beacon Light . . . . .	20-39
<b>ENGINE INSTRUMENTS</b>			
Fuel Gage and Transmitter . . . . .	20-18	Flashing Beacon Light . . . . .	20-40
Fuel Gage and Transmitter . . . . .	20-19	Flashing Beacon Light . . . . .	20-41
Carburetor Air Temperature Gage . . . . .	20-20	Control Wheel Map Light . . . . .	20-42
Hourmeter . . . . .	20-21	Control Wheel Map Light . . . . .	20-43
<b>FLIGHT INSTRUMENTS</b>			
Turn and Bank . . . . .	20-22	Flashing Beacon . . . . .	20-44
Optimum Flight Instrument . . . . .	20-22A	Strobe Light . . . . .	20-45
Turn Coordinator . . . . .	20-22B	Strobe Light . . . . .	20-46
Turn and Bank Indicator . . . . .	20-23	<b>HEATING, VENTILATING AND DE-ICING</b>	
Brittain Wing Leveler . . . . .	20-24	Cigar Lighter . . . . .	20-47
Encoding Altimeter . . . . .	20-24A	Cigar Lighter . . . . .	20-48
<b>OTHER INSTRUMENTS</b>			
Clock . . . . .	20-25	Pitot Heater . . . . .	20-49
Clock . . . . .	20-26	Pitot Heater . . . . .	20-50
<b>LIGHTING</b>			
		<b>CONTROL SURFACES</b>	
		Electric Wing Flaps and	
		Flap Position Indicator . . . . .	20-51
		Electric Wing Flaps . . . . .	20-52
		Flap Position Indicator . . . . .	20-53

BEGINNING WITH 1976 MODELS

Ground Service Receptacle . . . . .	20-55	Compass and Instrument	
Bus Bar, Primary, Alternator		Lights . . . . .	20-70
and Electronic . . . . .	20-56	Compass and Instrument	
Alternator System 60 Amp . . . . .	20-57	Lights . . . . .	20-71
Alternator System 60 Amp . . . . .	20-58	Instrument Panel Post Lighting . . . . .	20-72
Ammeter . . . . .	20-59	Instrument Panel Post Lighting . . . . .	20-73
Battery Circuit . . . . .	20-60	Dome and Courtesy Lights . . . . .	20-74
<b>IGNITION</b>			
Magneto System . . . . .	20-61	Landing and Taxi Lights . . . . .	20-75
<b>FUEL AND OIL</b>			
Oil Temperature . . . . .	20-62	Landing and Taxi Lights . . . . .	20-76
<b>ENGINE INSTRUMENTS</b>			
Fuel Gage and Transmitter . . . . .	20-63	Navigation Lights . . . . .	20-77
Hourmeter . . . . .	20-64	Flashing Beacon Light . . . . .	20-78
<b>FLIGHT INSTRUMENTS</b>			
Turn Coordinator . . . . .	20-65	Control Wheel Map Light . . . . .	20-79
Turn and Bank Indicator . . . . .	20-66	Strobe Light . . . . .	20-80
Encoding Altimeter . . . . .	20-67	<b>HEATING, VENTILATING AND DE-ICING</b>	
<b>OTHER INSTRUMENTS</b>			
Clock . . . . .	20-68	Cigar Lighter . . . . .	20-81
<b>LIGHTING</b>			
Map and Auxiliary Instrument . . . . .	20-69	Pitot Heater . . . . .	20-82
		<b>CONTROL SURFACES</b>	
		Electric Wing Flaps . . . . .	20-83
		Electric Wing Flaps . . . . .	20-84
		Flap Position Indicator . . . . .	20-85

NOTES:

- 1. APPLICABLE MODELS; 172I & FITZ
- ▶ THRU SER (SR6042) & (SR6045)
- ▶ SER (SR6042) & (SR6045) & ON

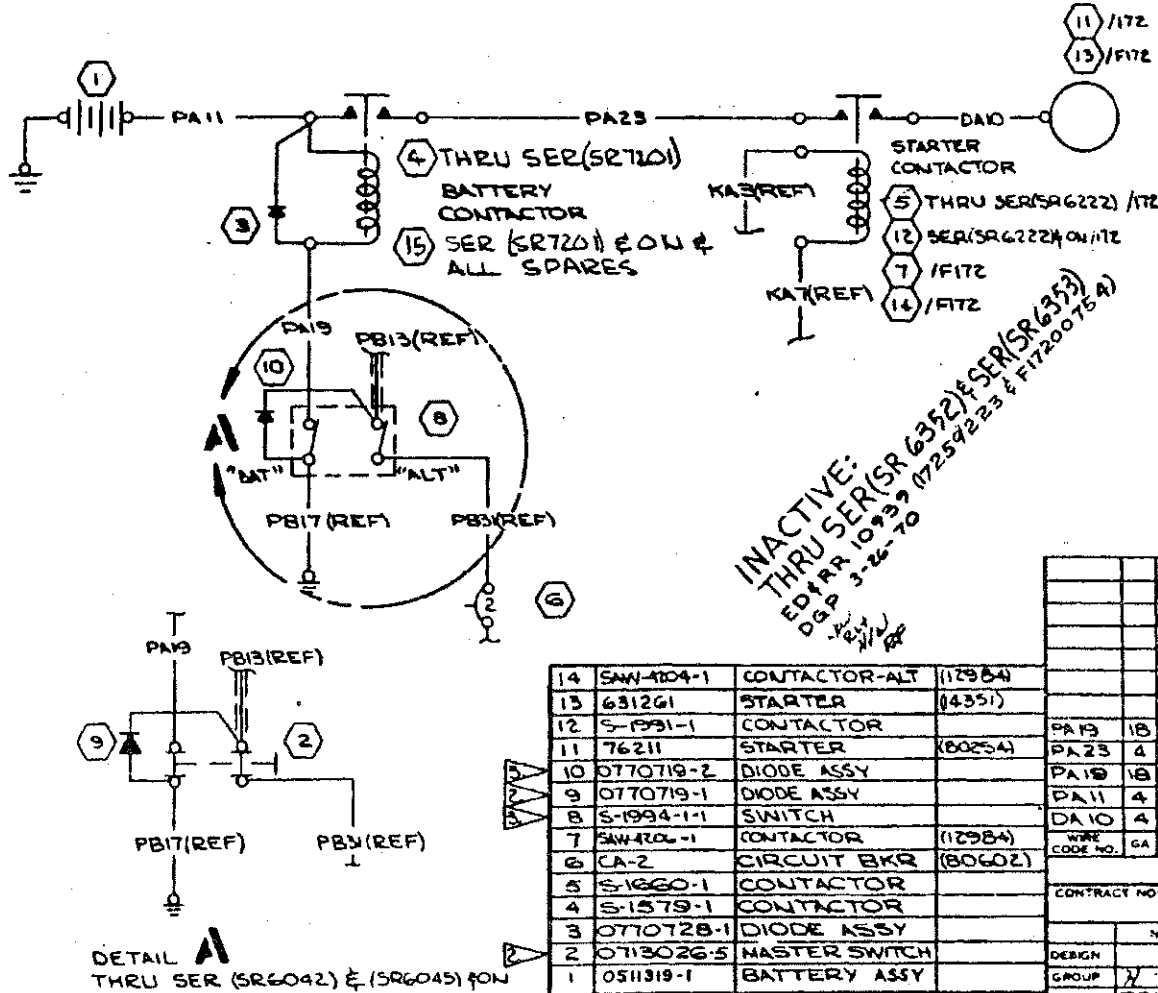

REVISION			
LET	DESCRIPTION	DATE	APPD
A	BY REV: PA23 46A WAS PA20 2 GA & S-1367-6-13 WAS S-1367-7-13 ED & RR 0155B	RLY 18-48	RLY JWH
B	BY REV: IN EQUIPMENT TABLE, "0511318-1 BATTERY ASSY" WAS "40712605 BATTERY" ED & RR 10012 (FR172E-0001) (172156513) IX	RBI 8-5-68	GRY MDS C.R. JWH
C	BY REV: SER OUT 0713026-5 & PA19; SER IN S-1994-1-1 & PA19; ADD DETAIL A & NOTES B & C; CA-2 WAS S-1707-60; DELETE PA2 (REF); ADD 0770719-1 & 0770719-2 ED & RR 10488 (SR6042) IX	DLB 4-4-69	JWH MDS JWH
D	BY REV: ADD "FITZ" TO NOTE 1, 637261, 76211, S-1991-1-1 & SAW-420L-1 CONTACTOR WAS SAW-420L-1 STARTER; (SR6042) & (SR6045) WAS (SR6050) IN NOTE 2 & 3 & DETAIL A; ADD SAW-420L-1 (SR6122) ED & RR 10476 (SR6042) (SR6050) IX	MDS 5-27-69	RLY MDS JWH
E	BY REV: SER OUT S-1579-1 & ADD S-1579-2 (SR7201)	BPH 7-26-72	JWH MDS JWH

INACTIVE:  
 THRU SER (SR 6392) & SER (SR 6353)  
 ED & RR 10999 (17259223 & FIT20075 A)  
 D & P 3-26-70

ITEM NO	PART NO.	DESCRIPTION	VENDOR
14	SAW-420L-1	CONTACTOR-ALT	(112984)
13	631261	STARTER	(84351)
12	S-1991-1	CONTACTOR	
11	76211	STARTER	(80254)
10	0770719-2	DIODE ASSY	
9	0770719-1	DIODE ASSY	
8	S-1994-1-1	SWITCH	
7	SAW-420L-1	CONTACTOR	(112984)
6	CA-2	CIRCUIT BKR	(80602)
5	S-1860-1	CONTACTOR	
4	S-1579-1	CONTACTOR	
3	0770728-1	DIODE ASSY	
2	0713026-5	MASTER SWITCH	
1	0511318-1	BATTERY ASSY	

WIRE CODE NO.	GA	MATERIAL	LG	TERMINALS	SERIALS
PA19	18			685-136716S-1493-1	
PA23	4			S-136760S-136761	
PA19	18			685-136716S-1493-1	
PA11	4			285-134710S-134711	
DA10	4			S-136760S-136761	

CONTRACT NO:			Cessna AIRCRAFT CO.		COMMERCIAL AIRCRAFT DIV.
DESIGN	NAME	DATE	WICHITA, KANSAS		
GROUP	H. W. Hill	9-29-67	<b>WIRING DIAGRAM - BATTERY CIRCUIT</b>		
DRAWN	PC ANTILL	9-27-67			
CHECK	LAURIE	9-27-67			
STRESS	M. W. Hill	1-18-68			
PROJECT	J. G. Kelle	1-19-67	SIZE	CODE IDENT. NO.	DWG NO.
APPRO	E. A. M. Hill	1-18-67	C	71379	0500062
SUPERSEDES:			SCALE: NONE		
SUPERSEDED BY: P 4.1.5			PAGE: 4.1.3		

ITEM NO	PART NO.	DESCRIPTION	VENDOR
15	S-1579-2	CONTACTOR	

(SER 1715653) & ON

REVISION			
LET	DESCRIPTION	DATE	APPD
A	BY REV: ADD PA31 & DA12 / FITZK ONLY EDERR 10071 (SR 6355) B	RLY 5-27-70	LW RF
B	BY REV: DELETE PB31(REF) FROM S-1415 EDERR 10172 SER 17259124	RLY 8-11-70	LW RF
C	BY REV: ADD WIRE LENGTH, S-1367-6-14 WAS S-1367-6-10 & S-1367-6-B PER PA11 (NOW SHOP PRACTICE)	PLD 4-9-73	LW RF

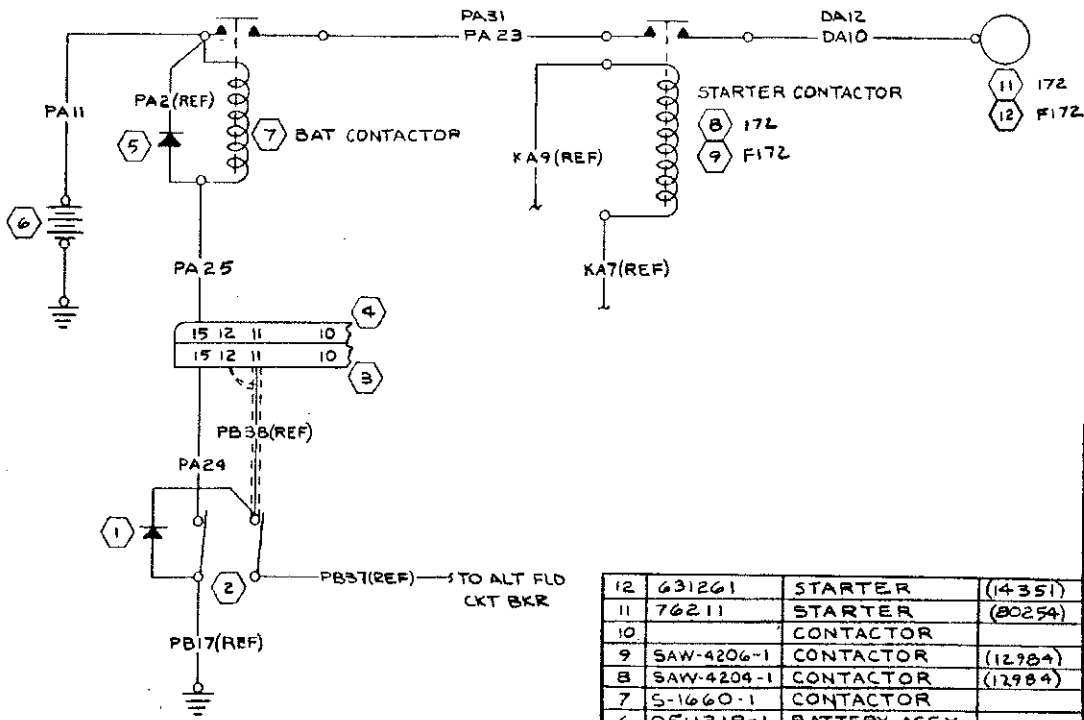

INACTIVE:  
 EFF THRU SER (SR 7003) II  
 (1726689-9) (F1720394)  
 10-23-74  
 RAM  
 RF

5060-112-50

ITEM NO	PART NO.	DESCRIPTION	VENDOR
12	631261	STARTER	((4351)
11	76211	STARTER	(80254)
10		CONTACTOR	
9	SAW-4206-1	CONTACTOR	(12984)
8	SAW-4204-1	CONTACTOR	(12984)
7	5-1660-1	CONTACTOR	
6	0511319-1	BATTERY ASSY	
5	0770728-1	DIODE ASSY	
4	5-1640-15	HOUSING - PIN	
3	5-1641-15	HOUSING - SOCKET	
2	5-1994-1-1	SWITCH	
1	0770719-2	DIODE ASSY	

WIRE CODE NO	GA	MATERIAL	LG	TERMINALS	SERIALS
DA12	4				S-1367-6-13S-1367-6-13 FITZK
PA31	4				S-1367-6-13S-1367-6-13 FITZK
PA25	18		50		S-1635-2S-1367-18
PA24	18		19		S-1636-2S-1493-1
PA23	4		12		S-1367-6-13S-1367-6-13 172L
PA11	4		6		S-1367-6-13S-1367-6-14
DA10	4				S-1367-6-13S-1367-6-13 172L

NOTES:  
 1. APPLICABLE MODELS: 172L, F172K

WIRE TABLE

CONTRACT NO. \_\_\_\_\_

DESIGN \_\_\_\_\_

GROUP *N. W. W.* 4-2-70

DRAWN *D.G. PLAIN* 3-26-70

CHECK *L.K. WHITE* 4-1-70

STRESS \_\_\_\_\_

PROJECT *41070* 4-10-70

APPD *R. HOLLGERS* 4-2-70

SIZE \_\_\_\_\_

CODE IDENT NO. **C 71379**

DWG NO. **0500062**

SCALE: NONE

PAGE: 4.1.5

CES-1000 IS APPLICABLE VENDOR CODES PER S-1400 CES-XXXX CESSNA SPEC. NO. S-XXX OR CMXXXX CESSNA STD. NO.

SUPERSEDES: **P 4.1.3**

SUPERSEDED BY: **0570101 P4.1.1**

EDERR 10939 SER(SR 6352) II (SR 6353) II

Change 3 20-3





SER 17254893 & ON

INACTIVE:  
EFF SER 17254893  
THRU SER 17259223  
ELY 4-3-70  
ELY REF JFW

FOR INSTL. OF CIRCUIT BREAKERS & WIRING  
REFERENCE RADIO INSTL. DWG. 0570400

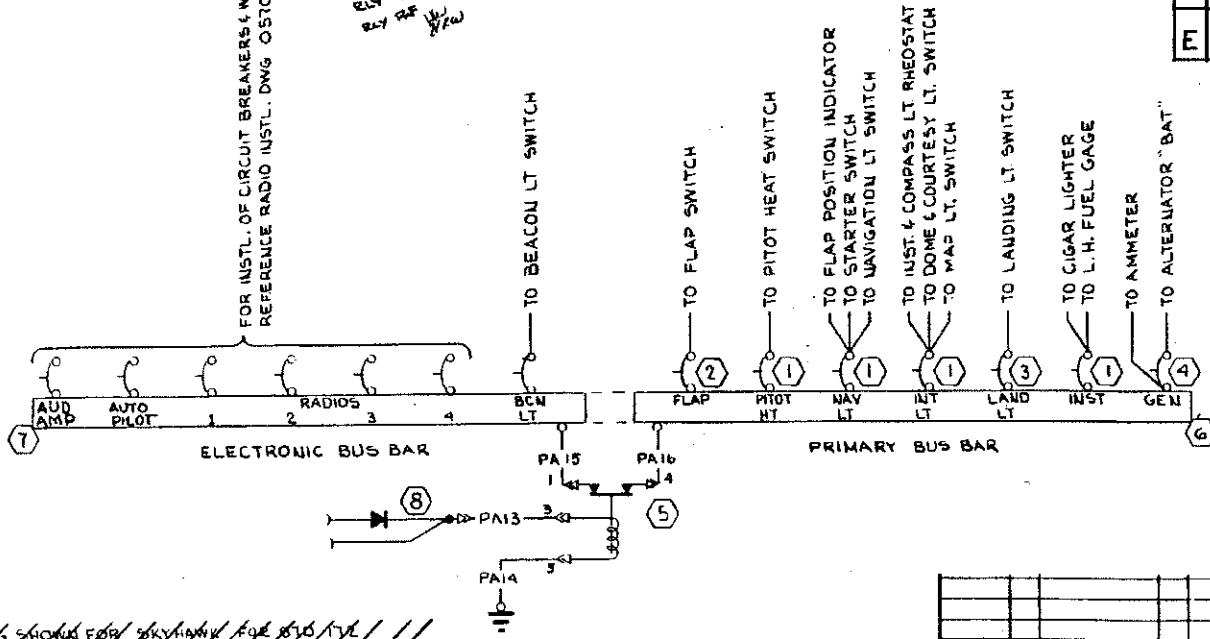

CRG LET	REVISION	DATE	BY	CHK
A	PA13 WAS PA11; PA16 WAS PA12; GEN WAS ALT. ADD DIA. NO. 3 TO S-1668-1; S-170043-1 WAS S-170043-1 (SEE 17254893) & ON	1-8-68	JES	JFW
B	BY REV: ADD FRITZE TO MODEL BLOCK (SEE F2172E-0001) & ON	8-8-67	CC	ALL
C	BY REV: DELETE FRITZE FROM MODEL BLOCK & NOTE; ADD S-1447 (SEE FRITZE-0001) & ON	5-14-67	JWM	RL
D	BY REV: ADD 1721 TO MODEL BLOCK	1-25-68	WRC	ALL
E	BY REV: DELETE NOTE 1 ED & RR 10018 (SR5522) II	7-5-68	RBI	ALL

NOTES:

1. WIRING SHOWN FOR SKY HAWK FOR 810 TVL WIRING IS IDENTICAL EXCEPT FOR 89.7X BUS BAR.

ITEM NO.	PART NO.	DESCRIPTION	INSTALLED ON
8	1510043-1	DIODE ASSY	
7	0570036-2	BUS BAR	
6	0570034-1	BUS BAR	
5	S-1668-1	RELAY	
4	S-1596-60	CIRCUIT BREAKER	
3	S-1360-20	CIRCUIT BREAKER	
2	S-1360-15	CIRCUIT BREAKER	
1	S-1360-10	CIRCUIT BREAKER	

WIRE CODE NO.	GA	MATERIAL	LG	TERMINALS	SERIALS
PA14	18			51493-1	5-13671-0
PA13	18			5-1493-1	5-1493-1
PA16	14			5-1493-2	5-13672-6
PA15	14			5-1493-2	5-13672-6

WIRE TABLE

CESSNA AIRCRAFT CO. COMMERCIAL AIRCRAFT DIVISION, WICHITA, KANSAS

DRAWN	BLISS	DATE	11-3-65	TITLE	WIRING DIAGRAM—
GROUP	W. W. W.	DATE	12-8-65		CIRCUIT BREAKER
CHECK	W. W. W.	DATE	12-21-65		WIRING
PROJ	W. W. W.	DATE	11-21-65		

PROJ NO: 0500062

SUPERSEDED BY: PA-6-2

APPROVED BY: 0500062 PP.45

MODEL: 172-172L

REV: E

PAGE: 4.8

Cessna.



NOTES (CONT):

- ▶ THRU SER F17200654 & FR172-0145
- ▶ SER F17200655 & FR172-0146 & ON

NOTES:

- ▶ 8 GA SHIELDED WIRE MATERIAL PER S-1534-B-9.
- ▶ OBSERVE POLARITY SYMBOL ON DIODE ASSY WHEN INSTL ON SWITCH TERM OR DIODE WILL FAIL WHEN SYSTEM IS ENERGIZED.
- ▶ AMP TERM 42281-2 ON CONDUCTOR. AMP TERM 2-323931-2 ON SHIELD & GND WIRE.
- 4. APPLICABLE MODELS; FRITZE , T41-C, & FITZ

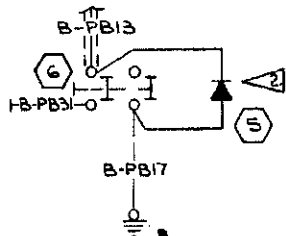
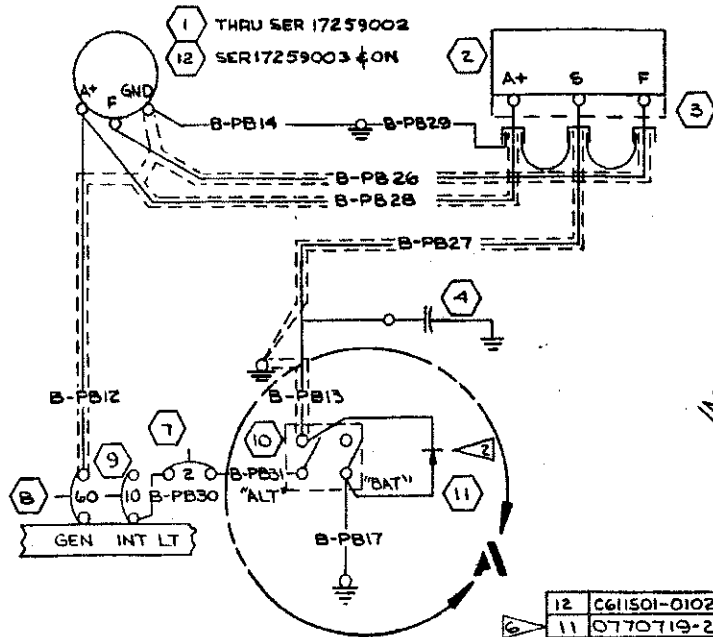

DETAIL A  
THRU SER F17200654, FR172-0145

INACTIVE:  
 SER FRITZE-0001 & RITZE-0257 THRU  
 SER FRITZE-0025, FITZ00754, SER 69-7756  
 SER FRITZE-0301  
 SER 10939  
 SER 3-24-70

REVISION			
LET	DESCRIPTION	DATE	APPRO
A	BY REV: ADD S-1360-10 & GEN TO BUS BAR; REROUTE B-PB30 WIRE FROM S-1596-60 TO S-1360-10; DELETE OPT FROM TITLE FRITZE-0001, RITZE-0257	CG 1-6-67	RLL Jun 1967
B	BY REV: DELETED S-1367-4-12 FROM WIRE B-PB12 & ADD S-1943-1. ADD 172 TO NOTE 4. (SR6043)	BPC 11/5/68	JWH N/W 11/5/68
C	BY REV: SER OUT 0713026-5, B-PB13, B-PB17 & B-PB31; SER IN S-1994-1-1, B-PB13, B-PB17 & B-PB31; ADD DETAIL A & NOTE 3 & 4; DELETE B-PB14; ADD 0770719-2 ED & RR 10488 (SR6045)(SR6050)II	DLB 4-4-68	JWH mod 11/11/68
D	BY REV: DELETE "SR6042" FROM NOTES 3 & 4 & DETAIL A; ADD "FITZ" TO NOTE 4. (SR6045)(SR6050)II	MDS 5-27-69	ELV mod 11/11/68
E	BY REV: SER OUT C611501-0101 (REF) & SER IN C611501-0102 (REF) ED & RR 10609 (SR6292)	RAINES 10/22/69	JWH mod 11/11/68

12	C611501-0102	ALTERNATOR ASSY	
11	0770719-2	DIODE ASSY	
10	S-1994-1-1	SWITCH	
9	S-1360-10	CIRCUIT BREAKER	
8	S-1596-60	CIRCUIT BREAKER	
7	CA-2	CIRCUIT BREAKER (80602)	
6	0713026-5	MASTER SWITCH	
5	0770719-1	DIODE ASSY	
4	0770038-2	FILTER	
3	C6AB-104730A	HOUSING (88690)	
2	C611001-0101	REGULATOR	
1	C611501-0201	ALTERNATOR ASSY	

PART NO.	DESCRIPTION
EQUIPMENT TABLE	
SUPERSEDES:	
SUPERSEDED BY: P 4.11.1	

WIRE CODE NO.	GA	MATERIAL	LG	TERMINALS	SERIALS
B-PB17	18		S-1367-8	S-1493-1	6
B-PB13	18S		S-1367-15	S-1493-1	6
B-PB31	18		S-1367-15	S-1493-1	6
B-PB31	18		S-1367-15	S-1493-1	6
B-PB30	18		S-1367-10	S-1567-1-B	5
B-PB29	16		S-1367-2-2		3
B-PB28	18S		S-1367-15	S-1493-1	6
B-PB27	18S		S-1367-15	S-1493-1	6
B-PB26	18S		S-1367-15	S-1493-1	6
B-PB17	18		S-1367-8	S-1493-1	6
B-PB14	10		S-1367-3-10	S-1367-3-12	5
B-PB13	18S		S-1367-15	S-1493-1	6
B-PB12	18S		S-1367-15	S-1493-1	6

WIRE TABLE

CONTRACT NO: \_\_\_\_\_

DESIGN: \_\_\_\_\_ NAME: \_\_\_\_\_ DATE: \_\_\_\_\_

GROUP: *2. New* 8-21-67

DRAWN: *HAZZIS* 9-13-67

CHECK: *LAURIE* 9-15-67

STRESS: *dup* 9-21-67

PROJECT: *06 Rollin* 8-21-67

APPD: *E.L. Moxak* 9-20-67

COMMERCIAL AIRCRAFT DIV.  
5800 E. PAWNEE  
WICHITA, KANSAS

Cessna AIRCRAFT CO.

TITLE  
**WIRING DIAGRAM -  
ALTERNATOR SYSTEM,  
60 AMP**

SIZE: **C** CODE IDENT. NO.: **71379** DWG NO.: **0500062**

SCALE: NONE PAGE: 4.11

(SER FRITZE-0001) & ON  
(SER RITZE-0257 THRU -0301)



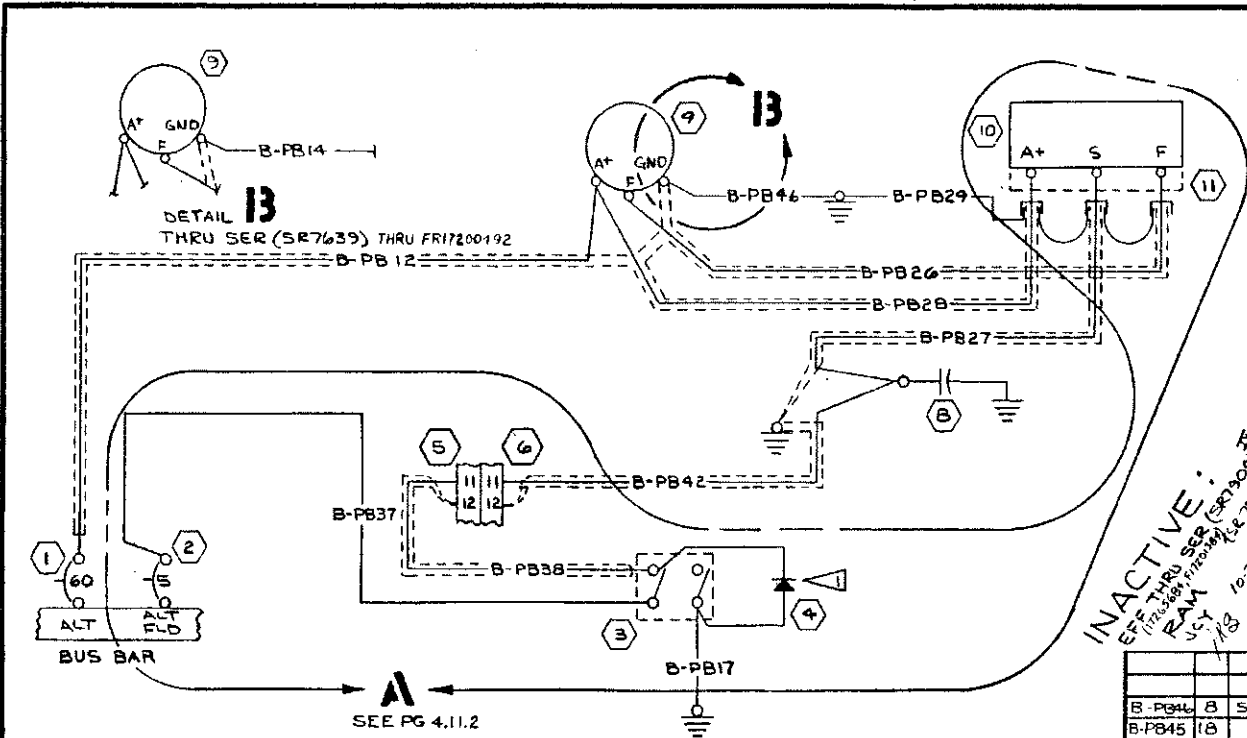

REVISION			
LET	DESCRIPTION	DATE	APPD
A	BY REV: ADD FITZK TO NOTES ED:RR 1017Z	RELV 8-17-70	RELV
B	BY REV: ADDED DETAIL A; S-2135-1 LIGHT ASSY; C593001-0101 OVERVOLTAGE SENSOR; WIRES B-PB43, B-PB44 & B-PB45. S-1943-2 TERM WAS S-1367-4-12 (SR6783 & 6784) X	WDA 4-26-71	N/W L/W R/F
C	BY REV: REPLACES S-1110-1 TERM WITH S-1635-1 TERM ON R PR 4.3. B-PB44 WIRE. ADDED S-1637-1 & S-1637-2 HOUSINGS, TVA-1315 CAPACITOR TO F/D & E/T SER 17260318 & ON	VRS 1-4-72	N/W R/F
D	BY REV: S-1367-2-B WAS S-1367-3-B PER PB42, S-1367-1-B WAS S-1367-3-B PER PB27. ADD WIRE LENGTH (NOW SHOP PRACTICE)	2LD 4-9-73	N/W R/F
E	BY REV: SER OUT CW1001-0101, SER IN CW1001-0102; ADD DETAIL 'B', PB46 & SER; SER OUT PB14 (SR7629) (SR7639)	RAM 7-31-73	N/W R/F

INACTIVE:  
SER OUT SER (SR7639) X  
RAM  
10-29-74  
1/8 10-29-74  
10-29-74

05-00062  
05-157-050

SEE PG 4.11.2

PART NO.	DESCRIPTION	VENDOR
17	CW1001-0102 REGULATOR	
16	TVA-1315 CAPACITOR	56289
15	S-1637-2 HOUSING-SOCKET	
14	S-1637-1 HOUSING-PIN	
13	S-2135-1 LIGHT ASSY	
12	C593001-0101 OVERVOLTAGE SENSOR	
11	CGAB-10A730A HOUSING	88690
10	CG11501-0101 REGULATOR	
9	CG11501-0102 ALTERNATOR ASSY	
8	0770038-2 FILTER	
7		
6	S-1640-15 HOUSING-PIN	
5	S-1641-15 HOUSING-SOCKET	
4	0770719-2 DIODE ASSY	
3	S-1994-1-1 SWITCH	
2	S-1360-5 CIRCUIT BREAKER	
1	S-1596-60 CIRCUIT BREAKER	

WIRE CODE NO.	GA	MATERIAL	LG	TERMINALS	SERIALS
B-PB44	8	S-1562-B-9		S-1943-3 S-1367-4-12	SR7639, 1726290, 17260318 & ON
B-PB45	18		60	S-1635-2 42281-2 (00779)	SER 17200805, FR17200276 & ON
B-PB44	18		28	S-1635-1 S-1636-2	
B-PB43	18		13	S-1367-1-6 S-1635-1	
B-PB42	18S		46	S-1635-2 S-1636-2	
B-PB38	18S		17	S-1493-1 S-1636-2	
B-PB37	18			S-1493-1 S-1367-1-6	THRU SER 17200804, FR17200276
B-PB29	16			S-1367-2-12	
B-PB28	18S			S-1367-1-10	
B-PB27	18S		12	S-1367-1-4 S-1367-1-8	
B-PB26	18S			S-1367-1-8 S-1367-1-8	
B-PB17	18		13	S-1367-1-8 S-1493-1	
B-PB14	10			S-1267-3-10 S-1367-3-12	FR17200276, 1726290, 17260318
B-PB12	8S	S-1534-B-9		S-1943-2 S-1367-4-10	

- NOTES:
- OBSERVE POLARITY SYMBOL ON DIODE WHEN INSTALLING ON SWITCH TO AVOID DIODE FAILURE
  - AMP TERM 42281-2 ON CONDUCTOR, AMP TERM 2-323931-2 ON SHIELD & GND WIRE
  - APPLICABLE MODEL: FR172H & FITZK

EQUIPMENT TABLE		
PART NO.	DESCRIPTION	VENDOR
17	CW1001-0102 REGULATOR	
16	TVA-1315 CAPACITOR	56289
15	S-1637-2 HOUSING-SOCKET	
14	S-1637-1 HOUSING-PIN	
13	S-2135-1 LIGHT ASSY	
12	C593001-0101 OVERVOLTAGE SENSOR	
11	CGAB-10A730A HOUSING	88690
10	CG11501-0101 REGULATOR	
9	CG11501-0102 ALTERNATOR ASSY	
8	0770038-2 FILTER	
7		
6	S-1640-15 HOUSING-PIN	
5	S-1641-15 HOUSING-SOCKET	
4	0770719-2 DIODE ASSY	
3	S-1994-1-1 SWITCH	
2	S-1360-5 CIRCUIT BREAKER	
1	S-1596-60 CIRCUIT BREAKER	

WIRE TABLE			
CONTRACT NO.	NAME	DATE	TITLE
	Cessna	4-7-70	WIRING DIAGRAM - ALTERNATOR SYSTEM, 60 AMP
DESIGN	C. O. O.	4-7-70	
GROUP	V. W.	4-2-70	
DRAWN	D.G. PLAIN	3-26-70	
CHECK	L.V. WHITE	4-2-70	
STRESS			
PROJ	2-2-70	4-7-70	
APPD	R. YOUNGERS	4-2-70	
OTHER			
SIZE	CODE IDENT NO	DWG NO	
C	71379	0500062	
SCALE	NONE	PAGE	4.11.1

CES-1000 IS APPLICABLE VENDOR CODES PER S-1400 CES-XXXX-CESNA SPEC. NO. S-XXX OR CMXXXX-CESNA STD. NO.

SUPERSEDES: P 4.11

SUPERSEDED BY: P 4.1 0570101 P 4.0

ED:RR 10939 SER (SR 6354) X FR1720226



NOTES:

▶ AMP TERM 42281-2 ON CONDUCTOR  
AMP TERM 2-323931-2 ON SHIELD  
& GROUND WIRE

▶ OBSERVE POLARITY SYMBOL ON  
DIODE ASSY WHEN INSTL ON SW  
TERM OR DIODE WILL FAIL WHEN  
SYSTEM IS ENERGIZED.

▶ THRU SER 17258486

▶ SER 17258487 & ON

REVISION			
LET	DESCRIPTION	DATE	APPD
A	BY REV: GEN WAS INT LT; ADD S-1360-10. ED:RR 02375 172-56513 II	LES	WEL MDS (1.2.11.10) DLC
B	BY REV: SER OUT 0713026-5, B-PB13 B-PB17 & B-PB31; SER IN S-1994-1-1, B-PB13, B-PB17 & B-PB31; ADD DETAIL A, NOTES 3 & 4 & 0770719-2 ED & RR 10488 (SR6042) II	DLB 6-4-69	JWH MDS 1/11/69 2011
C	BY REV: IN NOTES 3 & 4 & IN DETAIL A SER(SR6042) WAS SER(SR6050). (SR6042) II	MDS 5-27-69	WEL MDS 1/11/69 RF

INACTIVE:  
 SER 172156513 THRU SER 17259225  
 SER F172-0432 THRU F172-0435  
 SER F172-0443  
 SER F172-0447 THRU SER  
 ED:RR 10939  
 3-24-70  
 WEL MDS  
RF

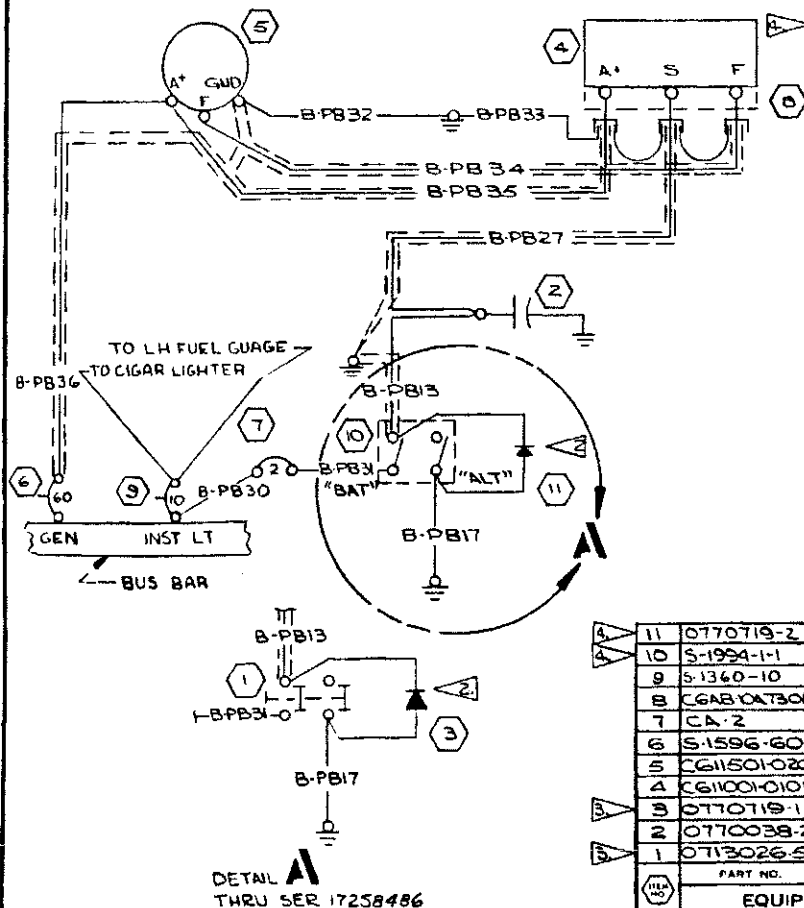

DETAIL A  
THRU SER 17258486

PART NO.	DESCRIPTION	QUANTITY	REMARKS
11	0770719-2	1	DIODE ASSY
10	S-1994-1-1	1	SWITCH
9	S-1360-10	1	CIRCUIT BKR
B	CGAB-0A730A	1	HOUSING (88690)
7	CA-2	1	CIRCUIT BKR (80602)
6	S-1596-60	1	CIRCUIT BKR
5	CG11501-0201	1	ALTERNATOR ASSY
4	CG11001-0101	1	REGULATOR
3	0770719-1	1	DIODE ASSY
2	0770038-2	1	FILTER
1	0713026-5	1	MASTER SWITCH

EQUIPMENT TABLE	
CES-1000 IS APPLICABLE VENDOR CODES PER 5-1400 CES-XXXX-CESSNA SPEC. NO. S-XXX OR CMXXX-CESSNA STD. NO.	SUPERSEDED BY: P 4.14.1

WIRE CODE NO.	GA	MATERIAL	LG	TERMINALS	SERIALS
B-PB17	18			S-1367-18	S-1493-1
B-PB13	18S			S-1367-18	S-1493-1
B-PB31	18			S-1367-18	S-1493-1
B-PB36	18S	S-1534-8-9		S-1367-18	S-1367-18
35	18S			S-1367-18	S-1367-18
34	18S			S-1367-18	S-1367-18
33	18			S-1367-18	S-1367-18
32	10			S-1367-10	S-1367-10
31	18			S-1367-18	S-1367-18
30	18			S-1367-18	S-1367-18
27	18S			S-1367-18	S-1367-18
17	18			S-1367-18	S-1367-18
B-PB13	18S			S-1367-18	S-1367-18

CONTRACT NO:		NAME		DATE	WIRE TABLE		
DESIGN		V. Wil		9-29-66	COMMERCIAL AIRCRAFT DIV. 5800 E. PANHUE WICHITA, KANSAS		
GROUP		RCATELL		9-27-67	Cessna AIRCRAFT CO.		
DRAWN		LAURIE		4-27-67	TITLE WIRING DIAGRAM - ALTERNATOR SYSTEM 60 AMP		
CHECK		STRESS		4-28-67	PROJECT D.C. Keller		
PROJECT		APPD		1-28-67	SIZE	CODE IDENT NO	DWG NO
C		71379		0500062	SCALE	NONE	1721
PAGE		4		14		(SER 172156513) & ON	

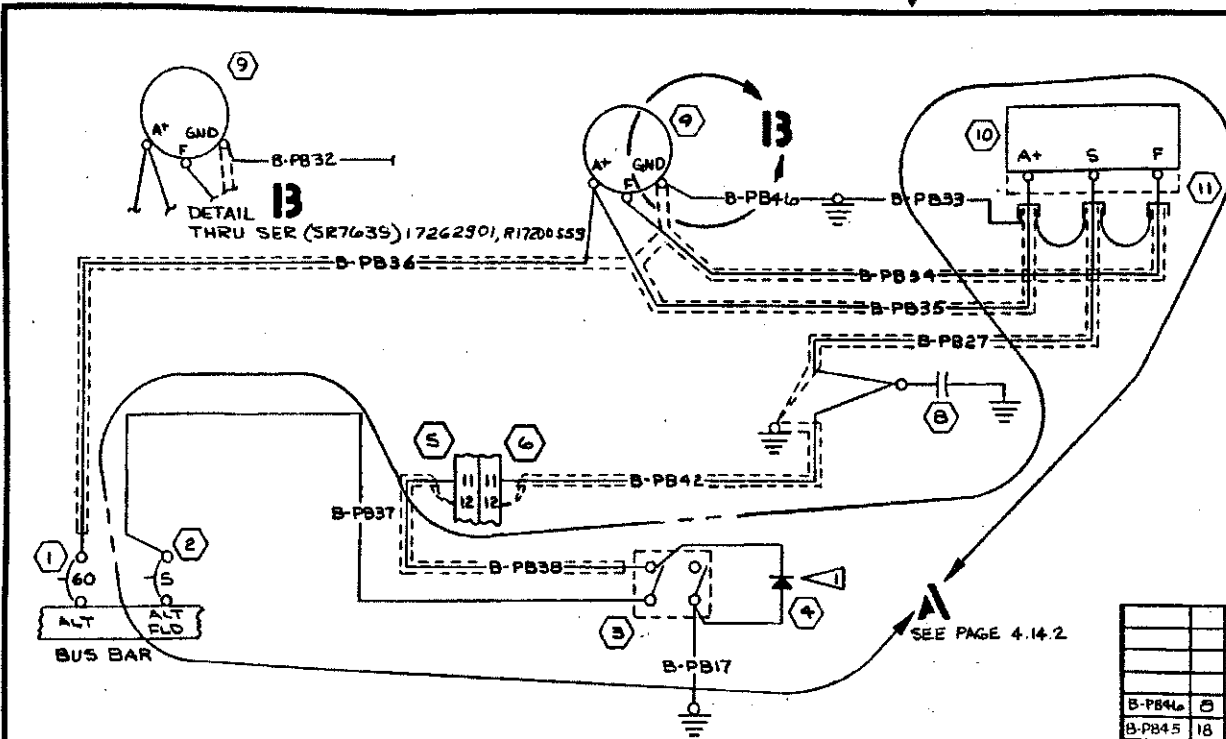

REV	DESCRIPTION	DATE	APPD
A	BY REV: DELETE FITZK MODEL REQ ED & RR 1017Z	8-11-70	WJW
B	BY REV: ADDED DETAIL A; S-2135-1 LIGHT ASSY; C593001-0101 OVER-VOLTAGE SENSOR; WIRES B-PB43, B-PB44 & B-PB45, S-1943-2 TERM WAS S-1567-4-12 (SR 6782) IX	6-1-71 WDA	NEW LHM OF 1 BAH
C	BY REV: ADD WIRE LENGTH (NOW SHOP PRACTICE)	9-9-73	JLO
D	BY REV: SER OUT C611001-0101, SER 113 C611001-0102; ADD DETAIL "B", PB46 & SER; SER OUT PB32 (SR7624) & (SR7639)	7-31-73	RAM
E	BY REV: ADD TVA-1315 CAPACITOR (NOW SHOP PRACTICE)	10-19-73	BAH

INACTIVE:  
 EFF THRU SER (SR7635)  
 R AM 10-25-74  
 JCY 10-25-74  
 WJW

- NOTES:**
1. OBSERVE POLARITY SYMBOL ON DIODE WHEN INSTALLING ON SWITCH TO AVOID DIODE FAILURE
  2. AMP TERM 42281-2 ON CONDUCTOR, AMP TERM 2-323931-2 ON SHEILD GND WIRE.
  3. APPLICABLE MODEL: 172L

PART NO.	DESCRIPTION	QUANTITY	TERMINALS	SERIALS
15	TVA-1315 CAPACITOR			
14	C611001-0102 REGULATOR			
13	S-2135-1 LIGHT ASSY			
12	C593001-0101 OVERVOLTAGE SENSOR			
11	C6AB-10A730A HOUSING			
10	C611001-0101 REGULATOR			
9	C611901-0102 ALTERNATOR ASSY			
8	O770038-2 FILTER			
7				
6	S-1640-15 HOUSING-PIN			
5	S-1641-15 HOUSING-SOCKET			
4	O770719-2 DIODE ASSY			
3	S-1994-1-1 SWITCH			
2	S-1360-5 CIRCUIT BREAKER			
1	S-1596-60 CIRCUIT BREAKER			

WIRE CODE NO	G.A.	MATERIAL	LG	TERMINALS	SERIALS
B-PB46	8	S-1562-8-9	55	S-1943-3 S-1367-4	SER 17259904 & R17200550 & ON
B-PB45	18	60 S-1635-2	42281-2 (00779)		SER 17259904 & ON
B-PB44	18	28 S-1370-1	S-1636-2		SER 17259904 & ON
B-PB43	18	13 S-13-71-6	S-1370-1		SER 17259904 & ON
B-PB42	18S		S-1493-1 S-1636-2		THRU SER 17259903
B-PB38	85				
B-PB37	18				
B-PB33	16		10	S-1367-12	
B-PB35	18S		55	S-1367-10	
B-PB27	18S		12	S-1367-14	
B-PB34	18S		12	S-1367-18	
B-PB17	18		13	S-1367-18 S-1493-1	
B-PB32	10		55	S-1367-340 S-1367-342	SER 17259904 & R17200550 & ON
B-PB36	85	S-1534-8-9	78	S-1367-310 S-1367-410	

EQUIPMENT TABLE	
CES-1000 IS APPLICABLE VENDOR CODES PER 3-1400 CES-XXXX-CESSNA SPEC. NO. S-XXX OR CMXXXX-CESSNA STD. NO.	SUPERSEDES: P 4.14 SUPERSEDED BY: P 4.4.1 O570101 P 4.4.0

WIRE TABLE			COMMERCIAL AIRCRAFT DIV. 5800 E. FAWCETT WICHITA, KANSAS	
CONTRACT NO:	NAME	DATE	Cessna AIRCRAFT CO.	
DESIGN GROUP	X. White	4-2-70	TITLE	
DRAWN	D.G. PLAIN	3-26-70	WIRING DIAGRAM -	
CHECK	J. WHITE	4-2-70	ALTERNATOR SYSTEM, 60 AMP	
STRESS			SIZE	CODE IDENT
PROJ	G.P. Life	4-10-70	C	71379
APPD	R. Younger	4-2-70	DWG NO	0500062
OTHER			SCALE	NONE
			PAGE	4.14.1



REVISION			
LET	DESCRIPTION	DATE	APPD
A	BY REV: SEE OUT 5-1320-1, SEE IN 5-1320-3; SEE OUT 5-1320-3, SEE IN 5-1320-5 (SR6879) (SR7120)	2-28-72	RLY N/W RF
B	BY REV: 39 LG WAS 29 & 5-1367-4-0 WAS 5-1367-4-6 PER DAB, 66 LG WAS 58 PER DAB (NOW SHOP PRACTICE)	3-16-73	JLO BY N/W RF

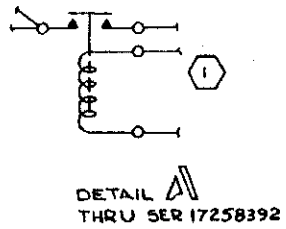
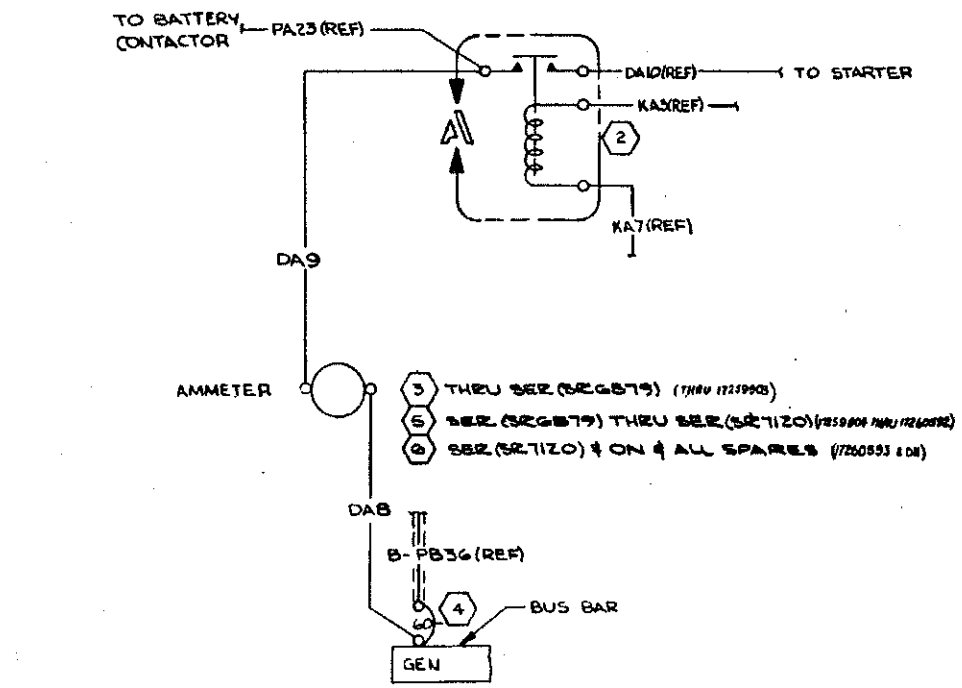

- ③ THRU SER (SR6879) (17180 17259908)
- ⑤ SER (SR6879) THRU SER (SR7120) (17258004 THRU 17260082)
- ⑥ SER (SR7120) & ON of ALL SPARES (17260593 & ON)

INACTIVE:  
 EFF THRU SER (SR7908) IF  
 (17263685, 17261384)  
 10-29-74  
 JST  
 RF

WIRE CODE NO	GA	MATERIAL	LG	TERMINALS	SERIALS
DAB	B		46	5-1367-4-10	5-1367-4-14
DA B	B		39	5-1367-4-10	5-1367-4-10

ITEM NO	PART NO.	DESCRIPTION
6	5-1320-5	AMMETER
5	5-1320-5	AMMETER
4	5-1707-60	CIRCUIT BKR
3	5-1320-1	AMMETER
2	5-1991-1	STARTER CONTACTOR
1	5-1660-1	STARTER CONTACTOR

EQUIPMENT TABLE	
CES-1000 IS APPLICABLE VENDOR CODES PER S-1400 CES-XXXX-CESSNA SPEC. NO. S-XXX OR CMXXXX-CESSNA STD. NO.	SUPERSEDES: P43.1 SUPERSEDED BY: OST0101 P43.0

WIRE TABLE		
CONTRACT NO:	NAME	DATE
DESIGN		
GROUP	<i>H. Hill</i>	<i>6-9-69</i>
DRAWN	<i>M. SWANEY</i>	<i>5-27-69</i>
CHECK	<i>E. YOUNGERS</i>	<i>5-28-69</i>
STRESS	<i>TULLIS</i>	<i>6-9-69</i>
PROJ	<i>P.F.H.</i>	<i>6-15-69</i>
APPD	<i>Albany</i>	<i>6-26-69</i>
OTHER		

COMMERCIAL AIRCRAFT DIV. 8800 E. PAWNEE WICHITA, KANSAS		
Cessna AIRCRAFT CO.		
TITLE <b>WIRING DIAGRAM — AMMETER</b>		
SIZE	CODE IDENT NO.	DWG NO.
C	71379	0500062
SCALE	NONE	172
PAGE: 4.15		

REVISION			
LET	DESCRIPTION	DATE	APPO
A	BY REV: SER OUT S-1320-1, SER IN S-1320-3; SER OUT S-1320-3, SER IN S-1320-5 (SR6B79) (SR7120)	2-28-72	RLY LW YFW RF
B	BY REV: 39LG WAS 29 & S-1367-4-10 WAS S-1367-4-6 PER DAB, 66LG WAS 59 PER DA9 NON SHOP PRACTICE	3-16-73	JLO RLY YFW RF

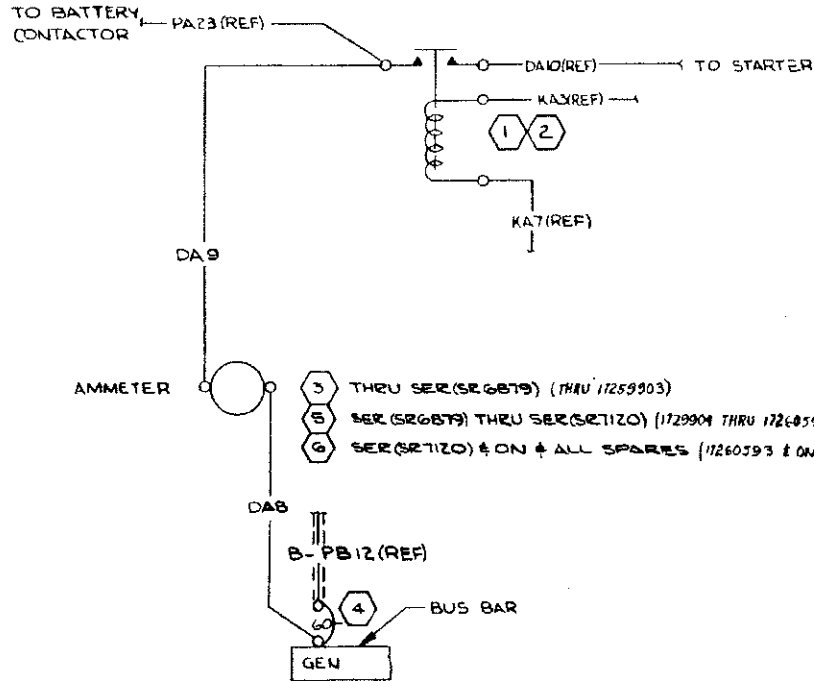

INACTIVE  
 EFF THRU SER (SR-7905)  
 RAM 100 (11260594, 11260595)  
 10-29-74  
 JCY  
 YFW RF

WIRE CODE NO.	GA	MATERIAL	LG	TERMINALS	SERIALS
DA9	B	66	S-1367-4-10	S-1367-4-14	
DAB	B	39	S-1367-4-10	S-1367-4-10	

PART NO.	DESCRIPTION
6	S-1320-5 AMMETER
5	S-1320-3 AMMETER
4	S-1707-60 CIRCUIT BRK
3	S-1320-1 AMMETER
2	SAW-4204-1 STARTER CONTACTOR-ALT
1	SAW-4206-1 STARTER CONTACTOR

EQUIPMENT TABLE	
CES 1000 IS APPLICABLE VENDOR CODES PER S-1400 CES-XXXX-CESSNA SPEC NO S-XXX OR CMXXXX-CESSNA STD. NO	SUPERSEDES P 4.3.1
	SUPERSEDED BY 0570101 P 4.5.0

CONTRACT NO.		NAME		DATE	COMMERCIAL AIRCRAFT DIV. 5800 E. FAWNEE WICHITA, KANSAS	
DESIGN	GROUP	H. W. W.	6-9-69	Cessna AIRCRAFT CO.		
DRAWN	CHECK	M. SWANEY	5-27-69	TITLE		
STRESS	OTHER	R. YOUNGERS	5-28-69	WIRING DIAGRAM — AMMETER		
PROJ	APPD	P. S. J.	6-7-69	SIZE	CODE IDENT NO	DWG NO
		M. Swaney	6-2-69	C	71379	0500062
SCALE		NO NE	FITZ	PAGE 4.16		

SERF172-0560 & ON

Change 3 20-15

REV	REVISION	BY	DATE	CHK	APPRO	CHG	REVISION	DATE	CHK	APPRO
P	BY REV: C292501-0105 SUPERSEDES C292501-0101 FOR ALL SPARES (SR172G)	RLY	3-1-72	WJ	RF	D	REDRAWN NO CHG	3-3-72	RF	RF
E	DELETED PARTS					F	DOUBLE SHIELDED WIRE CHANGED TO SINGLE SHIELD ON JAI & JAZ	11-16-61	WRC	RF
G	ADD NOTE 1 & 5 1488-1 NIPPLE					H	ADD STARTER CONTACTOR, BUS BAR, DETAILS FIELD 44 DA 2. ADD WIRE NO. 4A1, KAZ, KAS, KAT. (SER FITZ-0430) (ON)	11-16-61	WRC	RF
J	BY REV: ADD FRITZE TO MODEL BLOCK (SER FRITZE-0001) (ON)					K	BY REV: ADD NOTE 3 ED & RR 00192 (SER RITZE-0001) 0257 THRU 0301 (SER FRITZE-0001) (ON)	8-28-61	WRC	RF
L	BY REV: ADD 172I TO NOTES ED & RR 00192 (ON)					M	BY REV: SER OUT DETAIL A (SR 5522) (ON)	6-6-61	WRC	RF
N	BY REV: ADD 1570043-1, 5-1660-1, 5-1591-1, PA17, NOTES 4, 5 & 6 & SWN-4004-1 (ALT). ED & RR 10476 SER 17258393 6 OV									

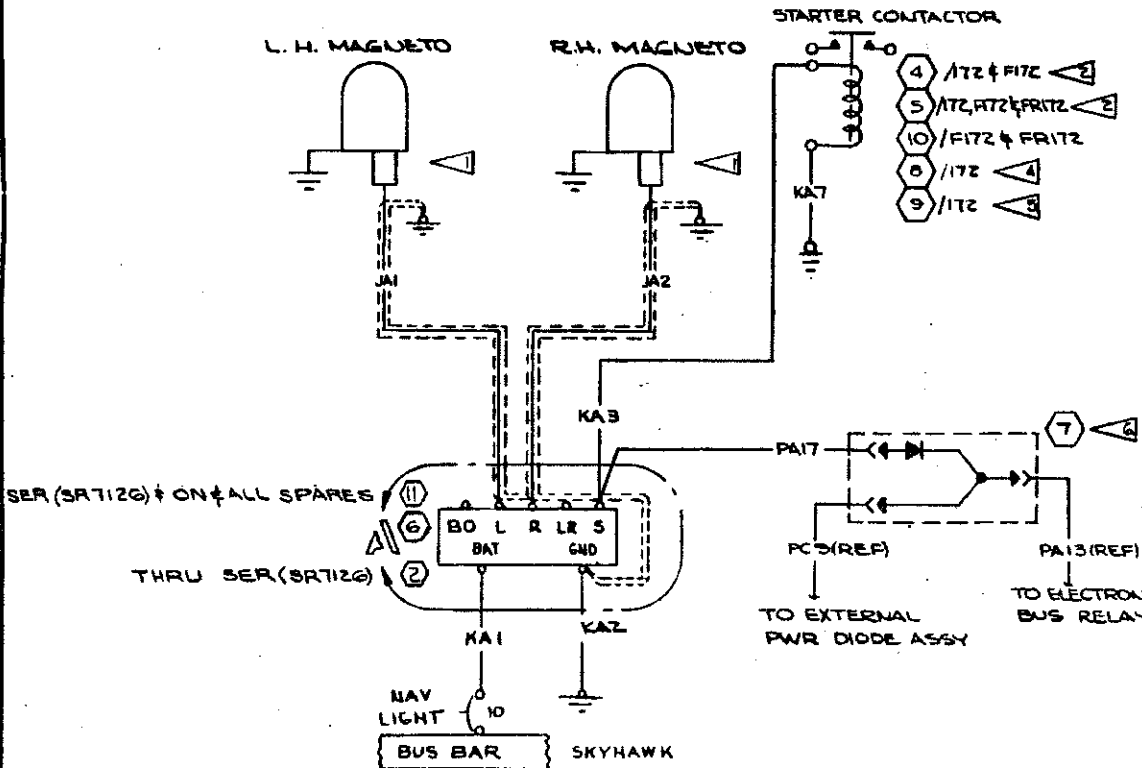

SER (SR172G) & ON & ALL SPARES  
THRU SER (SR172G)

- NOTE:
- 1 ADD 5-1488-1 NIPPLES TO MAG END OF WIRES
  - 2 4 APPLICABLE THRU SER 172 55146 & SER 172-0429
  - 3 5 APPLICABLE SER 172 55147 THRU SER 172 56512; SER 172-0430 & SER FRITZE-0001 & ON
  - 3 APPLICABLE MODELS; 172, FRITZE, T41-C, & 172I
  - 4 SER 172 56513 THRU SER 172 58392
  - 5 SER 172 58393 & ON
  - 6 SER 172 54895, SER 172-0320 & SER FRITZE-0001 & ON

QTY	PART NO.	DESCRIPTION	INSTALLED ON
11	C292501-0105	IGN SWITCH	
10	SWN-4004-1	CONTACTOR-ALT (12984)	
9	5-1591-1	CONTACTOR	
8	5-1660-1	CONTACTOR	
7	1570043-1	DIODE ASSY	
6	5-1406-1	SWITCH IGN T41-C	
5	SAW-4206-1	STARTER CONTACTOR (12984)	
4	1118823	STARTER CONTACTOR (12755)	
3	C292501-0201	SWITCH IGN 172-FRITZE	
2	C292501-0101	SWITCH IGN 172	
1	5-1360-10	CIRCUIT BREAKER	

WIRE CODE NO.	GA	MATERIAL	LG	TERMINALS	SERIALS
PA17	18		5-1367-10	5-1403-1	
KAT	18		5-1367-10	5-1367-10	
KA1	18		11 5-1367-10	5-1367-10	
KA3	18		48 5-1367-10	5-1367-10	
KA2	18		4 5-1367-10	5-1367-10	
JA1	18S		5-1367-10	5-1367-10	
JA2	18S		5-1367-10	5-1367-10	
JA1	18S		5-1367-10	5-1367-10	

WIRE TABLE		
NAME	DATE	TITLE
CONCEPT	3/1/72	WIRING DIAGRAM -
GROUP	2/1/72	MAGNETO SYSTEM -
CHECK	2/1/72	
PREP	2/1/72	

INACTIVE:  
THRU SER 172 6352  
SER 172 6353 (SER 172 6354)  
ED & RR 10939 (FRITZE 0001)  
SER 172 6355 (FRITZE 0001)  
SER 172 6356 (FRITZE 0001)  
SER 172 6357 (FRITZE 0001)  
SER 172 6358 (FRITZE 0001)  
SER 172 6359 (FRITZE 0001)  
SER 172 6360 (FRITZE 0001)  
SER 172 6361 (FRITZE 0001)  
SER 172 6362 (FRITZE 0001)  
SER 172 6363 (FRITZE 0001)  
SER 172 6364 (FRITZE 0001)  
SER 172 6365 (FRITZE 0001)  
SER 172 6366 (FRITZE 0001)  
SER 172 6367 (FRITZE 0001)  
SER 172 6368 (FRITZE 0001)  
SER 172 6369 (FRITZE 0001)  
SER 172 6370 (FRITZE 0001)  
SER 172 6371 (FRITZE 0001)  
SER 172 6372 (FRITZE 0001)  
SER 172 6373 (FRITZE 0001)  
SER 172 6374 (FRITZE 0001)  
SER 172 6375 (FRITZE 0001)  
SER 172 6376 (FRITZE 0001)  
SER 172 6377 (FRITZE 0001)  
SER 172 6378 (FRITZE 0001)  
SER 172 6379 (FRITZE 0001)  
SER 172 6380 (FRITZE 0001)  
SER 172 6381 (FRITZE 0001)  
SER 172 6382 (FRITZE 0001)  
SER 172 6383 (FRITZE 0001)  
SER 172 6384 (FRITZE 0001)  
SER 172 6385 (FRITZE 0001)  
SER 172 6386 (FRITZE 0001)  
SER 172 6387 (FRITZE 0001)  
SER 172 6388 (FRITZE 0001)  
SER 172 6389 (FRITZE 0001)  
SER 172 6390 (FRITZE 0001)  
SER 172 6391 (FRITZE 0001)  
SER 172 6392 (FRITZE 0001)  
SER 172 6393 (FRITZE 0001)  
SER 172 6394 (FRITZE 0001)  
SER 172 6395 (FRITZE 0001)  
SER 172 6396 (FRITZE 0001)  
SER 172 6397 (FRITZE 0001)  
SER 172 6398 (FRITZE 0001)  
SER 172 6399 (FRITZE 0001)  
SER 172 6400 (FRITZE 0001)





SER17254893 & ON

NOTES;  
 WIRE MATERIAL PER 5-1460

CHG LET	REVISION	BY DATE	CHK APPD
A	BY REV: C669507-0101 WAS C669504-0202, ADD FITZ, 0513144-18 & SER, C669507-0102 & SER.	MDS 5-21-68	ECY MDS DET /M RF

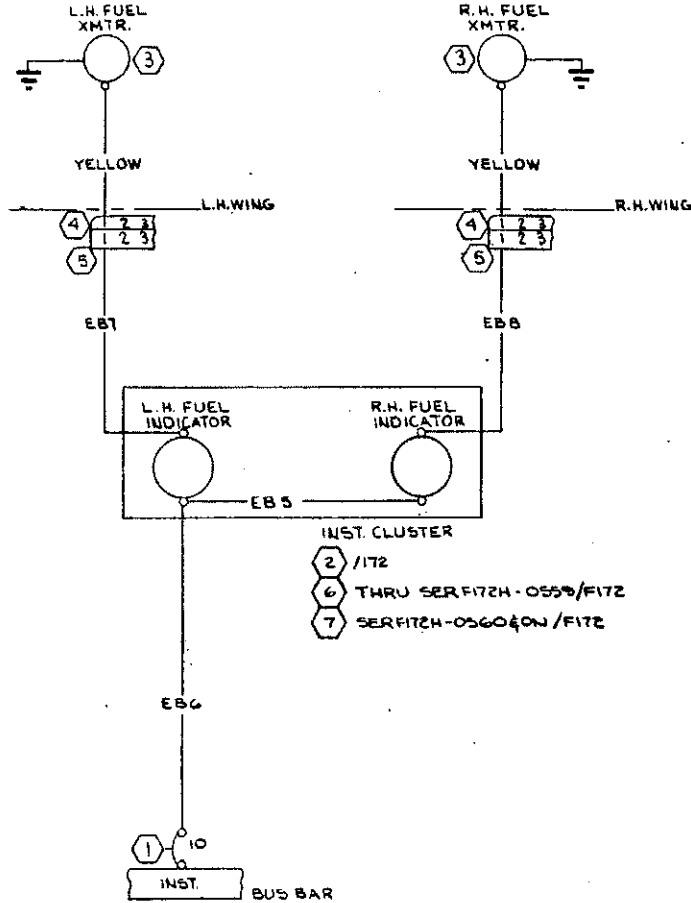

- INST. CLUSTER
- 2 /172
  - 6 THRU SERF172H-0559/FITZ
  - 7 SERF172H-0560&ON/FITZ

INACTIVE:  
 LEFT SER17254893 & SERF172-0320  
 THRU SER17259223 & SERF17200754  
 E.D.R.R. 8-26-70  
 E.D.R.R. 8-26-70  
 E.D.R.R. 8-26-70

WIRE CODE NO.	GA	MATERIAL	LG	TERMINALS	SERIALS
YELLOW	18	-18-4	5-1435-2	5-1367-1-10	
YELLOW	18	-18-4	5-1435-2	5-1367-1-10	
EBB	18		5-1367-1-10	5-1436-2	
EBT	18		5-1367-1-10	5-1436-2	
EBG	18		5-1367-1-6	5-1367-1-10	
EBS	18		5-1367-1-10	5-1367-1-10	

PART NO	DESCRIPTION	INSTALLED ON
7	C669507-0102 INST. CLUSTER	
6	0513144-18 PANEL ASSY	
5	5-1441-6 HOUSING-SOCKET	
4	5-1440-6 HOUSING-PIN	
3	0523557-1 XMTR-FUEL GAGE	
2	C669507-0101 INST. CLUSTER	
1	5-1360-10 CIRCUIT BREAKER	

WIRE TABLE

CESSNA AIRCRAFT CO. COMMERCIAL AIRCRAFT DIVISION, WICHITA, KANSAS

DATE	BY	TITLE
11-3-65	BLISS	WIRING DIAGRAM -
12-16-65	H. WIND	FUEL GAGE &
12-17-65	E. STICK	TRANSMITTER
12-20-65	W. H. HARRIS	

DWG NO: 0500062  
 REV: A PAGE: 8.1.1  
 SUPERSEDED BY: P.B.I.3 SUPERSEDED: 0500062 PP.B.1 MODEL: 172A FITZ

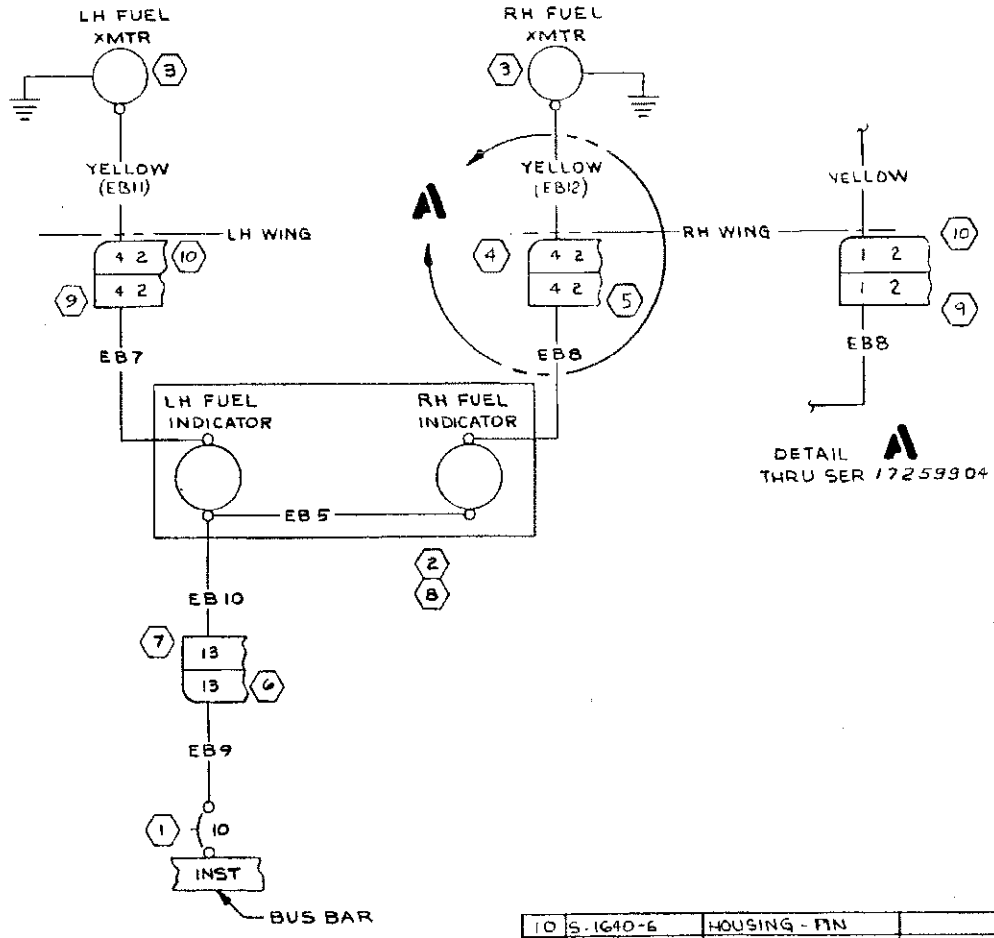

DETAIL A  
THRU SER 17259904 & F17200804

REVISION			
LET	DESCRIPTION	DATE	APPD
A	BY REV: ADD DETAIL A: ADD S-1638-1 & S-1638-2. (SR6584)	WPC 2-3-71	WPC NF
B	BY REV: ADD WIRE LENGTHS (NOW SHOP PRACTICE)	JLO 4-9-73	JLO NF
C	BY REV: YEL (EB11) WAS YEL, YEL (EB12) WAS YEL. S-1635-1 WAS S-1635-2/ YEL (EB11) YEL (EB12) & EB9; S-1636-1 WAS S-1636-2/ EB10 EBB & EB7; S-1640-4 WAS S-1640-6; S-1641-9 WAS S-1641-6; S-1640-6 WAS S-1640-9; S-1641-6 WAS S-1641-9; DETAIL "A" (172 E0007) (NOW SHOP PRACTICE)	JEF 2/8/74	JEF NF
D	BY REV: S-1641-6 & S-1640-9 WAS S-1641-9 & S-1640-9. INACT DWG (NOW SHOP PRACTICE); (172903)	RAM 10-19-74	RAM NF

INACTIVE:  
 EFF THRU SER (SR7903) IX  
 (172669, 172700)  
 10-29-74  
 RAM  
 JCY  
 JRS  
 NF

23-23X-0904

WIRE NO.	GA	MATERIAL	LG	TERMINALS	SERIALS
YEL (EB12)	18	-18-4	38	S-1635-1	S-1367-10
YEL (EB11)	18	-18-4	38	S-1635-1	S-1367-10
EB10	18			S-1367-10	S-1636-1
EB9	18		13	S-1367-10	S-1635-1
EB8	18		86	S-1367-10	S-1636-1
EB7	18		51	S-1367-10	S-1636-1
EB5	18		7	S-1367-10	S-1367-10

PART NO.	DESCRIPTION	QUANTITY	REMARKS
10	S-1640-6 HOUSING - PIN		
9	S-1641-6 HOUSING - SOCKET		
8	C669507-0102 INST CLUSTER F172		
7	S-1641-13 HOUSING - SOCKET		
6	S-1640-15 HOUSING - PIN		
5	S-1641-9 HOUSING - SOCKET		
4	S-1640-9 HOUSING - PIN		
3	0523557-1 XMTR - FUEL GAGE		
2	C669507-0101 INST CLUSTER 172		
1	S-1360-10 CIRCUIT BREAKER		

EQUIPMENT TABLE	
CES-1000 IS APPLICABLE	SUPERSEDES: P 8.1.1
VENDOR CODES PER S1400	SUPERSEDED BY: 0570101 P 8.1.0
CES-XXXX: CESSNA SPEC. NO.	
S-XXX OR CXXXX: CESSNA	
STD. NO.	

CONTRACT NO.			COMMERCIAL AIRCRAFT DIV. 5800 E PAWNEE WICHITA, KANSAS		
DESIGN	NAME	DATE	Cessna AIRCRAFT CO.		
GROUP	D.G. PLAIN	3-26-70	TITLE		
DRAWN	L.Y. WHITE	8-1-70	WIRING DIAGRAM - FUEL GUAGE & TRANSMITTER		
CHECK	PROJECT	4-2-70	SIZE	CODE IDENT NO.	DWG NO.
STRESS	APPD	4-2-70	C	71379	0500062
SCALE: NONE			PAGE: 8.1.3		

NOTES:  
1. APPLICABLE MODEL: 172, F172

Change 3 20-19

ED:RKC 10/1/70  
SER(SR 6352) IX  
SER(SR 6353) IX

1. ALL APPLICABLE PARTS TO BE INSTALLED AS SHOWN IN THIS WIRING DIAGRAM.  
 2. THE WIRING DIAGRAM IS TO BE USED TO MAKE WIRE PROBLEMS EASIER.

3. APPLICABLE MODELS; 172

CHG LET	REVISION	BY DATE	CHK APPD
F	BY REV: ADD FRITZE TO MODEL BLOCK (SER FEITZE-000) (N)	C.G. 8-8-67	RLA
G	BY REV: ADD NOTE 3 & DELETE FRITZE (SER FEITZE-ED & ROOTS 000) (N)	RCA 8-8-67	RLA

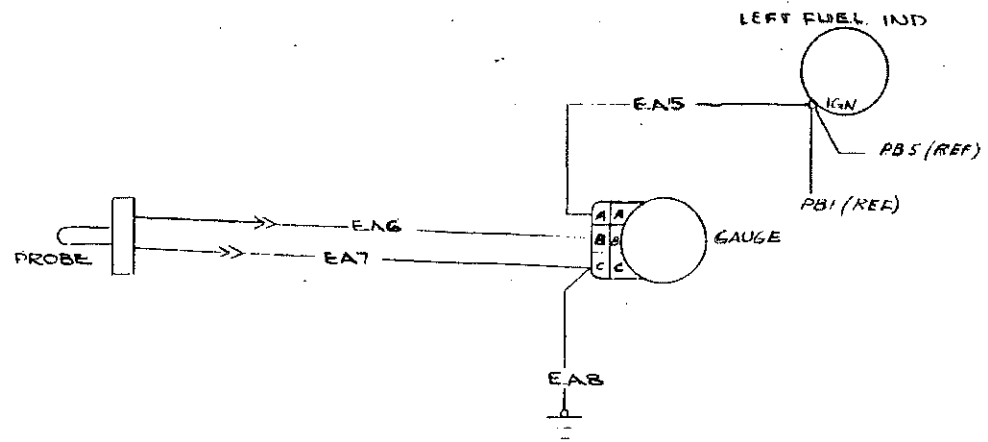

INACTIVE;  
 EFF THRU SER (SER 73003)  
 (712/884-112/1334)  
 11-12-74  
 RAM  
 8/17/87  
 RB

SOGC-1-E-80

WIRE CODE NO.	GA	MATERIAL	LG	TERMINALS	SERIALS
EAG	18	---	---	---	---
EA7	18	---	---	---	---
EAB	18	---	---	---	---
EAS	18	---	---	---	---
				N/A	

WIRE TABLE

CESSNA AIRCRAFT CO., COMMERCIAL AIRCRAFT DIVISION, WICHITA, KANSAS

NAME	DATE	TITLE	
DRAWN: CRIVELLO	4/5/69	WIRING DIAGRAM -	
GROUP: DITTMER	4/1/69	CARBURETOR	
CHECK: COOK	4/1/69	AIR TEMPER-	
PROJ: SATTLER	4/1/69	ATURE GAUGE	
SUPERSEDED BY:		SUPERSEDES:	MODEL:
		NOTE 1	NOTED
Dwg No. 0500062		REV: G	PAGE: 8.2

PART NO.	DESCRIPTION	INSTALLED ON

EQUIPMENT TABLE

SER 17256355 & ON

CHG LET	REVISION	BY	CHK
		DATE	APPRO
A	BY DEV: SER OUT S-1579-1 E ADD S-1579-2 (S-7201)	RPW 4-11-62	WVW 4-11-62
B	BY REV: S-1367-1-B WAS S-1367-1-G PER DF2 & DF3, S-1367-1-B WAS S-1367-1-G PER DF4, ADD WIRE LENGTHS (NON SHOP PRACTICE)	JLD 9-9-73	WVW 9-9-73

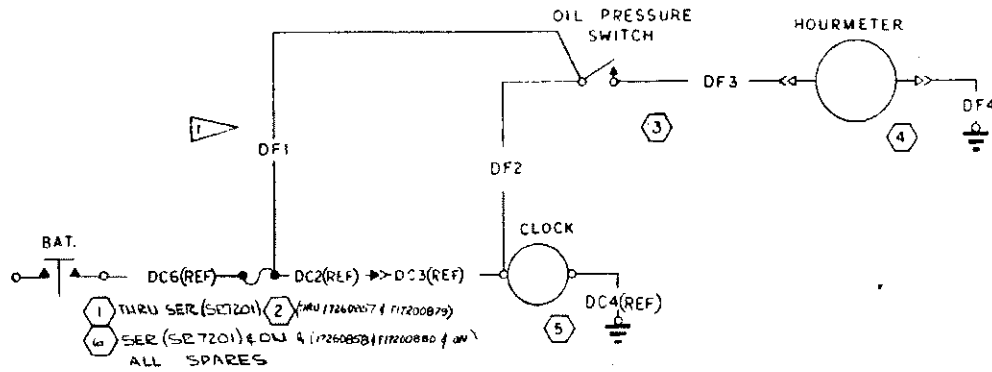

**NOTE:**

WIRING DIAGRAM SHOWN IS FOR USE WHEN AN OPTIONAL ELECTRIC CLOCK IS INSTALLED. WHEN ELECTRIC CLOCK IS NOT INSTALLED WIRE B-DF1 CONNECTS PRESSURE SWITCH TO FUSEHOLDER INSTALL 5-1091-1 FUSE AND 5-1690-22 FUSEHOLDER.

INACTIVE:  
 EFF THRU SER (S-1367-1-B)  
 (17256355 & 17220184)  
 BY RPW  
 4-11-62

S-1367-1-B

WIRE CODE NO.	GA.	MATERIAL	LG.	TERMINALS	SERIALS
DF4	18		B	S-1493-1	S-1367-1
DF3	18		54	S-1493-1	S-1367-1-B
DF2	18		53	S-1367-1-G	S-1367-1-B
DF1	18			S-1367-1-G	SOLDER

**WIRE TABLE**

CESSNA AIRCRAFT CO. COMMERCIAL AIRCRAFT DIVISION, WICHITA, KANSAS

ITEM	PART NO.	DESCRIPTION	INSTALLED ON
6	S-1579-2	CONTACTOR	
5	S-1317N1	CLOCK	
4	2664501-5101	HOURLMETER	
3	S-1711-1	OIL PRESSURE SW.	
2	S-1091-1	FUSE	
1	S-1579-1	BAT CONTACTOR	

**EQUIPMENT TABLE**

DRAWN: WEDL DATE: 3-21-66  
 CHECKED: WEDL DATE: 7-27-66  
 APPROVED: WEDL DATE: 9-28-66  
 TITLE: **WIRING DIAGRAM - HOURLMETER (OPT)**

DRAWING NO: **2500062**  
 REV: **B** PAGE: **8.3**



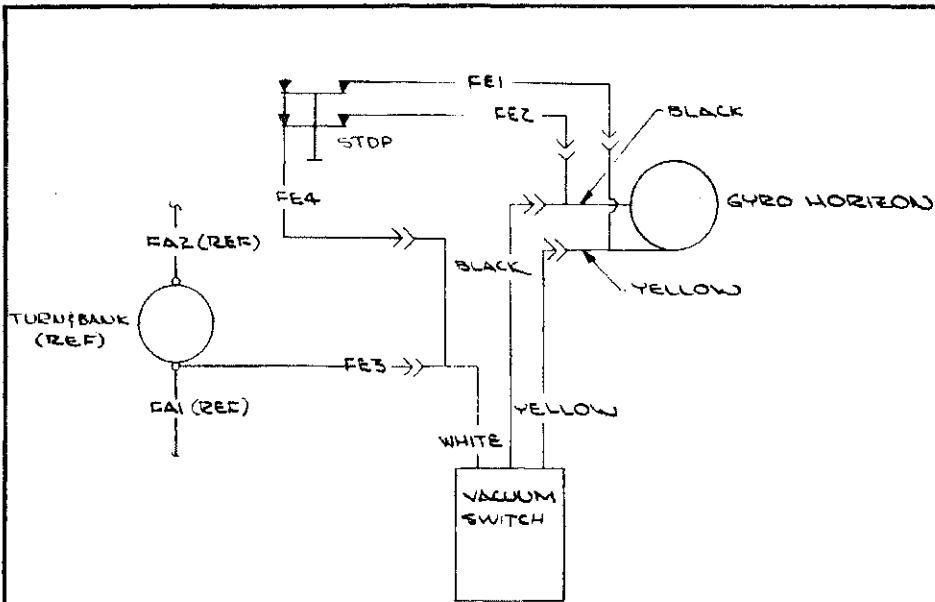

**NOTES:**

1. FE1, FE2, FE3, & FE4 ARE IDENTICAL TO & SUPERSEDE OS3198-CE1, -FE2, FE3, & -FE4 RESPECTIVELY

CHG LET	REVISION	BY	CHK
D	ADDED FAITHRU CDA & NOTE 1	FEI	FEI
E	DELETED PREVIOUS	FEI	FEI
F	BY REV: ADD FR172 TO MODEL BLOCK (SER FR172E-0001) ON	C.G.	RL
G	BY REV: DELETE FR172 FROM MODEL BLOCK	BLA	BLA

INACTIVE:  
 EFF THRU SER 17250572 & P17257188  
 RAM 1-88  
 11-12-74

WIRE CODE NO	GA	MATERIAL	LG	TERMINALS	SERIALS
FE4 20		S-341-2			
FE3 20		S-341-2	5-1367-1-B		
FE2 20		S-341-2			
FE1 20		S-341-2			

**WIRE TABLE**

CESSNA AIRCRAFT CO., COMMERCIAL AIRCRAFT DIVISION, WICHITA, KANSAS

NAME	DATE	FILE
DRAWN: BRISWOLD	11/8/59	
GROUP: DITTMER	11/2/59	
CHECK: COE	11/1/59	
PROJ: SATTLEG	11/2/59	

**WIRING DIAGRAM — OPTIMUM FLIGHT INSTRUMENTS (OPT)**

**Cessna.**

DWG NO: 0500062

SUPERSEDED BY: NOTE 1    SUPERSEDES:    MODEL: 172-P172    REV: F    PAGE: 3.2

PART NO	DESCRIPTION	INSTALLED ON
<b>EQUIPMENT TABLE</b>		

NOTES:

1. APPLICABLE MODELS; FRITZ ,172 & F 172

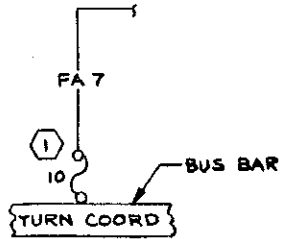

DETAIL 13  
THRU SER 17259223, F17200754, & F17200225

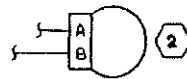
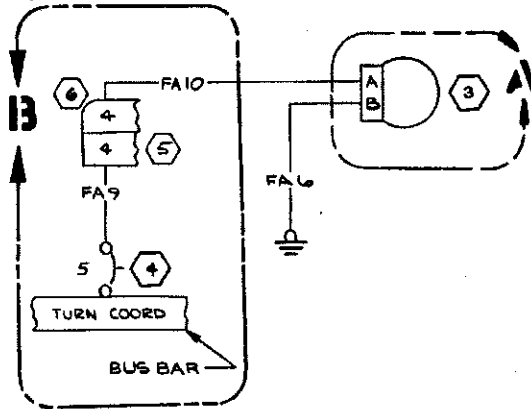

DETAIL A  
EFF THRU SER FITZ-0555 & SER 1725161

6	S-1640-15	HOUSING-PIN
5	S-1641-15	HOUSING-SOCKET
4	S-1360-5L	CIRCUIT BREAKER
3	CG61003-0501	TURN COORDINATOR
2	CG61003-0201	TURN COORDINATOR
1	S-1091-10	FUSE

ITEM NO.	PART NO.	DESCRIPTION
	EQUIPMENT TABLE	

INACTIVE:  
EFF THRU SER (SR1900) (SR1900)  
RAM (SR1900) (SR1900)  
10-29-74 (SR1900) (SR1900)  
RF

REVISIONS			
LTR	DESCRIPTION	DATE	APPROVED
A	BY REV: ADD NOTE 1; DELETE (SR5471). ED & RR 0017E (SER FR172E-000) & ON	7-8-67 RCA	R.L. HAY W/W
B	BY REV: ADD 1721 TO NOTE 1 ED & RR 00192 (SER 1721S603) & ON	9-27-67 JSM	R.L. HAY W/W RF W/W
C	BY REV: ADDED DETAIL A & ITEM 3. ED & RR 02375 (SR5605) & (SR5522) II	LE5 6-12-68	GEI W/W W/W D&K
D	BY REV: ADD & SER OUT DETAIL B; ADD FA9 & FA10, F172 TO NOTE 1; 172 & FR172E WAS 172I & FR172E IN NOTE 1; ADD S-1640-15, S-1641-15 & S-1360-10 ED & RR 10939 (SR6352) (SR6353) (SR6354)	DGP 1-26-70	W/W W/W RF
E	BY REV: S4360-5L WAS S4360-10 (NOW SHOP PRACTICE)	10-5-72 RCA	W/W D&K RF
F	BY REV: ADD WIRE LENGTHS (NOW SHOP PRACTICE)	JLO 8-9-75	W/W RF
G	BY REV: 5 WAS 10, ON DWG FIELD ITEM 4 (NOW SHOP PRACTICE)	MEM 5-9-74	W/W RF

WIRE CODE NO.	MATERIAL	LG.	TERMINALS	SERIALS
FA 10	1B	28	S-1635-2	SOLDER
FA 9	1B	9	S-1367-1-6	S-1636-2
FA 6	1B	23	S-1367-1-8	SOLDER
FA 7	1B		S-1367-1-4	SOLDER

CONTRACT NO:		WIRE TABLE		COMMERCIAL AIRCRAFT DIV. 5800 E. PAWNEE WICHITA, KANSAS	
DESIGN	NAME	DATE	Cessna AIRCRAFT CO.		
GROUP	H. W. W.	8-11-67	TITLE		
DRAWN	HARRIS	8-8-67	WIRING DIAGRAM - TURN COORDINATOR		
CHECK	LAURIE	8-10-67	SIZE	CODE IDENT.	DWG NO.
STRESS		8-15-67	C	71379	0500062
PROJECT	J. S. W.	8-11-67	SCALE: NONE	PAGE: 9/3	
APPD	J. W.	8-11-67	SUPERSEDED BY: 0570101 P 91.0		



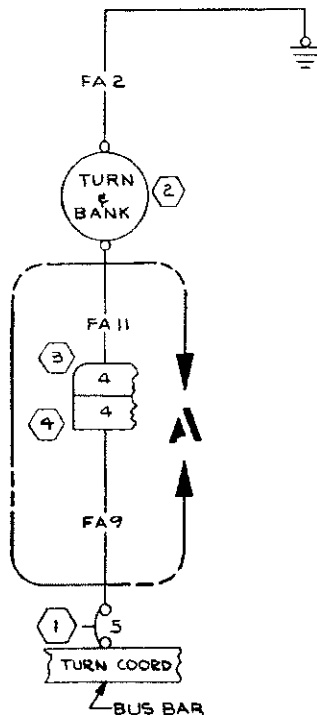

NOTES:  
1. APPLICABLE MODELS; 172, FR172, T41-C, F172, T41-A

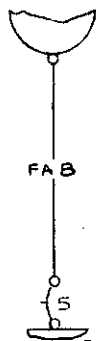

DETAIL A  
THRU SER 17259223, F17200754 & FR17200225

REVISION			
LET	DESCRIPTION	DATE	APPD
A	BY REV: ADD 172I TO NOTE 1 ED & RR 00192 (SER 172156513) 40N	9-21-67 JSM	FLI WV
B	BY REV: ADD SER DETAIL A; ADD FA 9 & FA 11, S-1640-15 & S-1641-15; ADD T41-A TO NOTE 1; FR 172 WAS FR 172 E & F172 WAS 172I IN NOTE 1 ED & RR 10939 (SR 6352) (SR 6353) (SR 6354) II	DGP 3-26-70	WV WV
C	BY REV: ADD WIRE LENGTHS, S-1413-2 WAS S-1413-1 (NOW SHOP PRACTICE)	JLO 4-9-73	WV WV
D	BY REV S-1360-5 WAS S-1360-10L (NOW SHOP PRACTICE)	MEM 3-3-74	WV WV

INACTIVE  
EFF THRU SER (SR 17259223) (SR 17200754)  
RAM  
JCY  
HIS RE

04-21-1975  
02-27-1975

ITEM NO	GA	MATERIAL	LG	TERMINALS	SERIALS
FA 11	10		23	S-1635-2 S-1367-1-B	
FA 9	10		9	S-1367-1-B S-1636-2	
FAB	10			S-1367-1-B S-1367-1-G	THRU (SR 6353) (SR 6354)
FAZ	10		20	S-1367-1-B S-1367-1-B	

CONTRACT NO:			COMMERCIAL AIRCRAFT DIV. 5800 E. PAWNEE WICHITA, KANSAS	
DESIGN	NAME	DATE	Cessna AIRCRAFT CO.	
GROUP	H. W. ...	9-21-67	TITLE	
DRAWN	HARRIS	9-21-67	WIRING DIAGRAM -	
CHECK	LAURIE	9-21-67	TURN & BANK INDICATOR	
STRESS			SIZE	CODE IDENT NO.
PROJECT			C	71379
APPD			DWG NO.	0500062
			SCALE: NONE	NOTED
			PAGE: 9.4	

ITEM NO	PART NO.	DESCRIPTION
4	S-1641-15	HOUSING-SOCKET
3	S-1640-15	HOUSING-PIN
2	S-1413-2	TURN & BANK IND
1	S-1360-5	CIRCUIT BREAKER

EQUIPMENT TABLE

CES-1000 IS APPLICABLE  
VENDOR CODES PER S-1400  
CES-XXXX-CESSNA SPEC. NO.  
S-XXX OR CMXXXX-CESSNA  
STD. NO.

SUPERSEDES:  
0500062, PG 9.1

SUPERSEDED BY:  
0570101 P 9.2.0

(SER FR 172E-0001, 40N (SER 172E-0257 THRU -0301)

Change 3 20-23





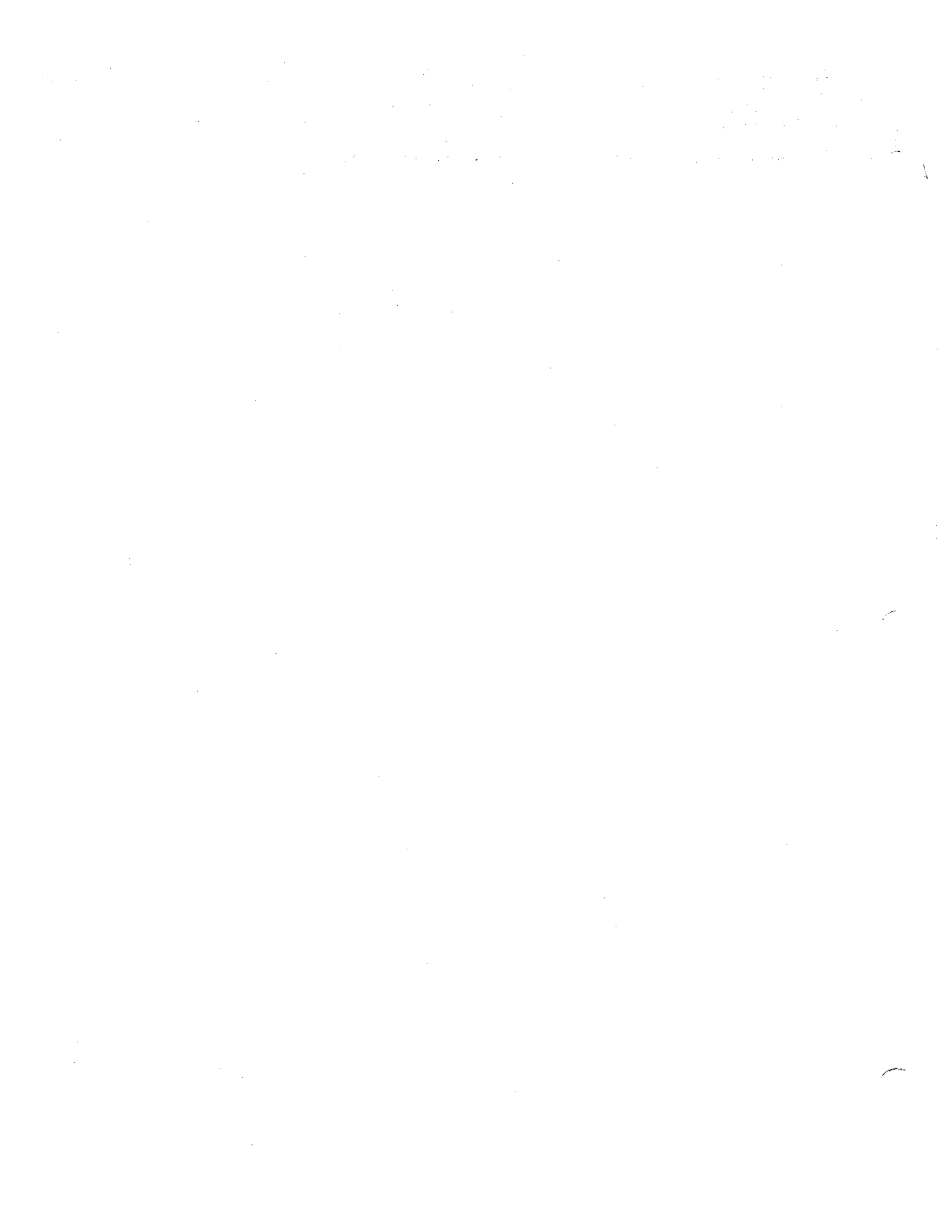

SER172499464  
SERP1725716340N

CHG LET	REVISION	BY	CHK
E	DELETED PREFIXES 1-1-68	W.A.P.	W.A.P.
F	BY REV: ADD DETAIL A, DC6 & SERIALS. SERIALIZE OUT DC1 (SR4640)	L.P.B.	L.P.B.
G	BY REV: S-1317N2 WAS S-1317N1	EDBRR10442	W.A.P.
H	BY REV: SER OUT S-1579-1 & ADD S-1579-2 (SR7201)	B.W.H.	W.A.P.

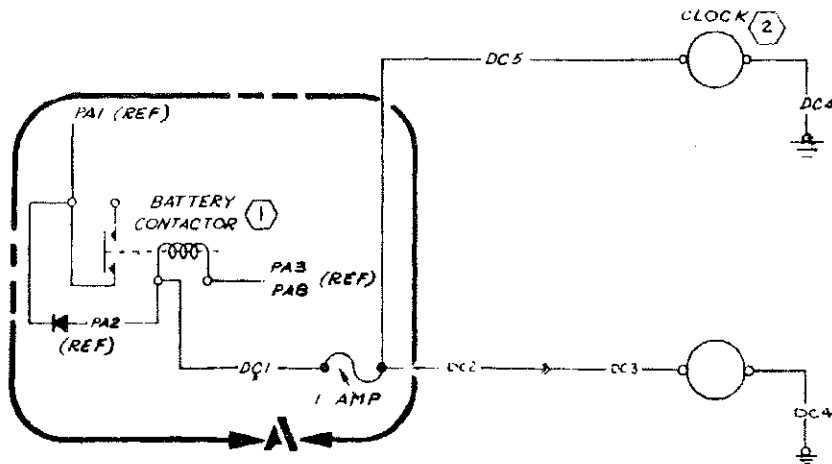

(172 CIRCUIT)  
(FITZ CIRCUIT)

(P172 CIRCUIT)

INACTIVE:  
EFF THRU SER 172618988 FF17201034  
5-21-73

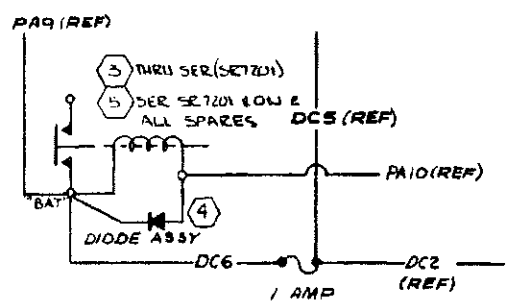

DETAIL A  
SER1725339340N

WIRE CODE NO	GA	MATERIAL	LG	TERMINALS	SERIALS
-DC6 18	13	S-1367-13	SOLDER		OPTIONAL 1725339340N
DC5 18	65	S-1367-14	SOLDER	172 ONLY	OPTIONAL 1724994640N
-DC4 18	10	S-1367-18	S-1367-14		OPT. 1725716340N
-DC3 18		S-341-2	S-1367-14	P172 ONLY	CFT. 1725716340N
-DC2 18		S-341-2	SOLDER	P172 ONLY	STD. 1725716340N
-DC1 18	13	S-1367-14	SOLDER		OPT. 1725716340N

ITEM NO	PART NO	DESCRIPTION	INSTALLED ON
5	S-1579-2	CONTACTOR	
4	0770728-1	DIODE ASSY.	
3	S-1579-1	CONTACTOR	
2	S-1317N2	CLOCK	
1	0712603-2	CONTACTOR	

WIRE TABLE			
CESSNA AIRCRAFT CO COMMERCIAL AIRCRAFT DIVISION, WICHITA KANSAS			
DRAWN	NAME	DATE	TITLE
CHKD	PARSONS	10-12-68	WIRING DIAGRAM -
CHKD	P. H. H.	10-11-68	CLOCK (OPT)
MOD	J. H. H.	10-15-68	
DESIGNED BY	ENGINEER	MODEL	REV
		72, P172	H
PAGE		10.1	
DWG NO		0500062	

NOTES:

1. APPLICABLE MODELS; FRITZ, T41-C 172 & F172

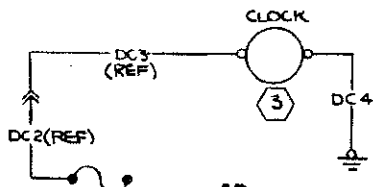

DETAIL **B**  
THRU SER (SR7304) (FR1720044D)

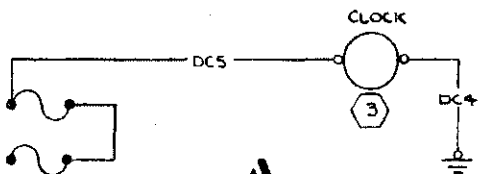
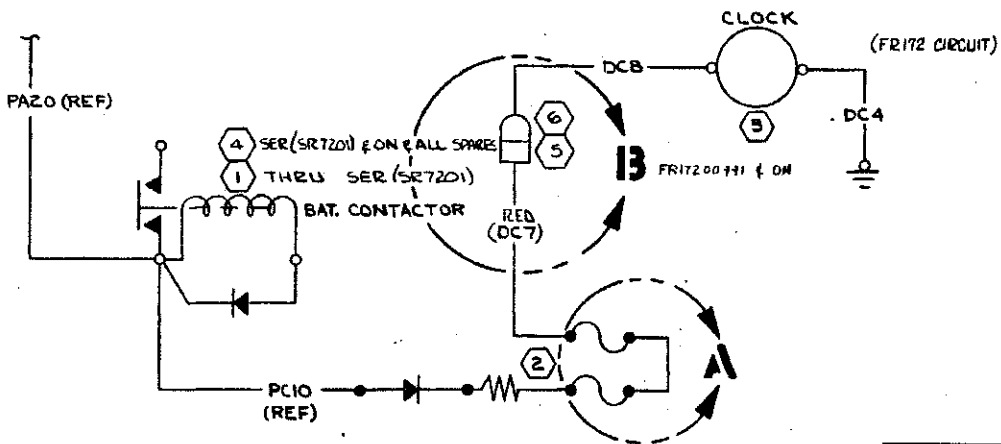

DETAIL **A**  
SER (SR 7303) THRU (SR7603) (17261899, F17201035 THRU 17263158, F17201234)

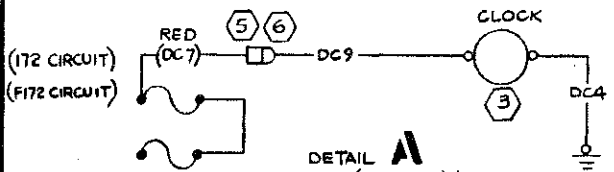

DETAIL **A**  
SER (SR 7603) & ON (17263457, F17201235 & ON)

6	5-1637-1	HOUSING
5	5-1637-2	HOUSING
4	5-1579-2	CONTACTOR
3	5-1317N2	CLOCK
2	0712031-3	FUSE & DIODE ASSY
1	5-1579-1	CONTACTOR

(MIN)	PART NO.	DESCRIPTION
	EQUIPMENT TABLE	

REVISIONS			
LTR	DESCRIPTION	DATE	APPROVED
A	BY REV: ADD NOTE 1 ED & RR 00173 (SER FRITZE-000) ON (SER R172E-0257 THRU -0301)	8-18-67	RCA
B	BY REV: ADD 172I TO NOTE 1 ED & RR 00192 (SER 172I) ON	9-27-67	R.L. Pym JSM
C	BY REV: SER OUT 5-1579-1 & ADD 5-1579-2 (SR7201)	6-16-74	BPH
D	BY REV: ADD DETAIL 'A' & 'B'; DC4 20 GA WAS 10 GA & DC5 79LG WAS 65 LG, ADD DC5, DC7 & DC8, ITEM 564, 172 WAS 172I & FRITZ WAS FRITZE, (NOW SHOP PRACTICE) (SR7303) (SR7304)	5-21-73	JMO RF
E	BY REV: ADD DC9; DETAIL A; RED (DC7) WAS DC7 (MER 180/185 E0041) (SR 7604)	5-22-74	JEF BRF

INACTIVE:  
EFF THRU SER (7903) (SR7303)  
(17263457 - 17201899)  
10-26-74  
RAM  
CY RE  
R/S

WIRE CODE NO.	MATERIAL	LG	TERMINALS	SERIALS
DC9 1B	5-1636-1	SOLDER		SER (SR 7603) & ON
DC8 1B	5-1635-1	5-1367-6		SER (SR 7304) & ON
RED (DC7) 1B	5-1636-1	SOLDER		SER (SR7303) & ON
DC5 1B	79 5-1367-6	SOLDER		OPT. 17249946 & ON
DC4 1B	20 5-1367-6	5-1367-6		OPT. 17249946 & ON

CONTRACT NO: \_\_\_\_\_

DESIGN NAME DATE

GROUP *H. Wild* 7-27-67

DRAWN *C. GARCIA* 8-8-67

CHECK *LAURIE* 8-10-67

STRESS *...* 7-15-67

PROJECT *...* 7-15-67

APPRO *...* 8-11-67

SUPERSEDED BY: 0570101 P 101.0

COMMERCIAL AIRCRAFT DIV.  
5800 E. PAWNEE  
WICHITA, KANSAS

Cessna AIRCRAFT CO.

TITLE  
**WIRING DIAGRAM -  
CLOCK**

SIZE CODE IDENT. DWG NO.  
C 71379 0500062

SCALE: NONE

PAGE: 10.2

(SER FRITZE-000) & ON

(SER 17251823 THRU SER 17259223)

REV	REVISION	BY	CHK
A	ADD 3 LA15, LA16, LA17 DELETED JUMPER WIRE ON SWITCH ADDED LA17, JUMPER FOR LA14 WIRE W/5.000R	MS	MS
B	ADDED DETAIL A, LA18, LB6, LB5, S-1638-1, S-1630-1, UNMOUNTED LA11	FRITZ	FRITZ
C	BY REV: ADD FRITZE TO MODEL BLOCK (SER FRITZE-0001) 50N	C.G.	RL

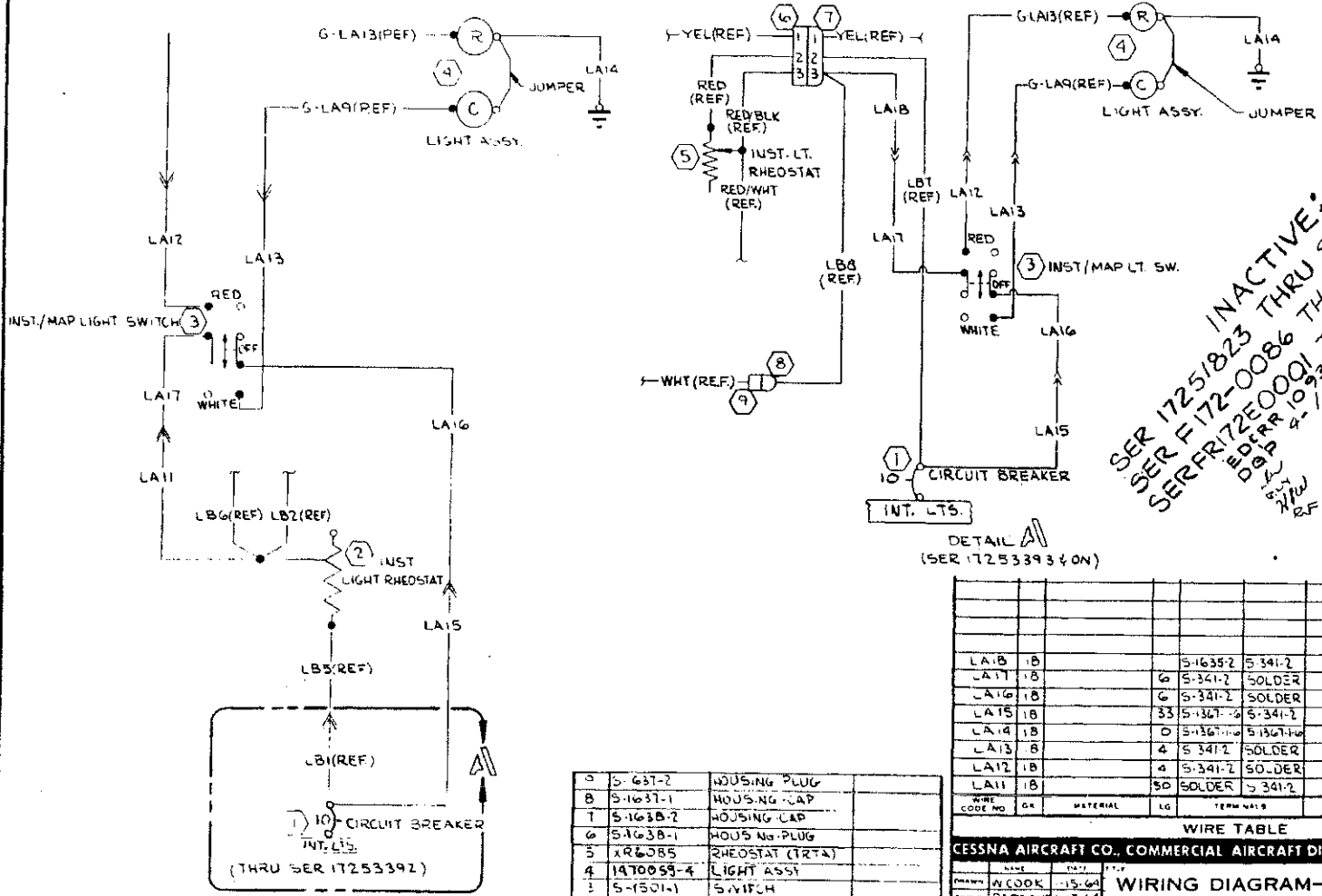

INACTIVE:  
 SER 17251823 THRU SER 17259223  
 SER F 172-0086 THRU SER F17200754  
 SER FRITZE0001 THRU SER FRITZE0002  
 DERR 10939  
 4-1-70  
 JFW  
 REF

DETAIL A  
(SER 17253393 & ON)

QTY	PART NO	DESCRIPTION	INSTALLED ON
5	5-637-2	HOUSING PLUG	
8	5-1638-1	HOUSING CAP	
7	5-1638-2	HOUSING CAP	
6	5-1638-1	HOUSING PLUG	
5	XR6085	RHEOSTAT (IRTA)	
4	1470059-4	LIGHT ASSY	
1	5-1501-1	SWITCH	
2	04-3126-5	RHEOSTAT ASSY	
1	5-1320-10	CIRCUIT BREAKER	

WIRE CODE NO	GR	MATERIAL	LG	TERMINALS	SERIALS
LA18	18		5-1635-2	5-341-2	SER 17253393 & ON
LA17	18		5-341-2	SOLDER	
LA16	18		5-341-2	SOLDER	
LA15	18		33 5-1367-2	5-341-2	
LA14	18		0 5-1367-1	5-1367-1	
LA13	18		4 5-341-2	SOLDER	
LA12	18		4 5-341-2	SOLDER	
LA11	18		50 SOLDER	5-341-2	THRU SER 17253392

WIRE TABLE

CESSNA AIRCRAFT CO., COMMERCIAL AIRCRAFT DIVISION, WICHITA, KANSAS

DESIGNED BY AL COOK 1-15-64	DATE 1-15-64	<b>WIRING DIAGRAM— MAP AND AUXILIARY INSTRUMENT LIGHT (OPT)</b>	
CHECKED BY R. J. J. J.	DATE 1-15-64		
PROJECT FRITZE	DATE 1-15-64		

PART NO: 0500062  
 SUPERSEDED BY: P 11.1.2  
 SUPERSEDER: 11.1  
 MODEL: 172-FRITZE  
 REV: C  
 PAGE: 11.1.1

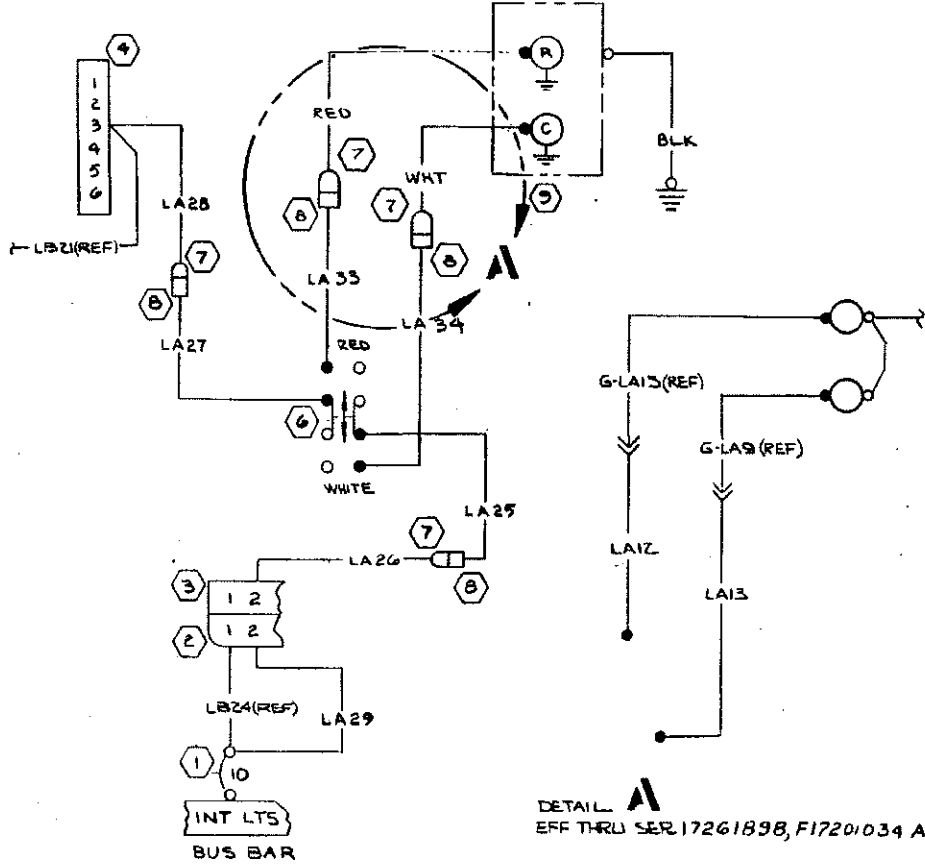

DETAIL A  
EFF THRU SER 17261898, F17201034 AND FR17200940

REVISION			
ITEM	DESCRIPTION	DATE	APP'D
A	BY REV: LEFT TO (SR7304) II 115 IN (WHT) (SR7304) (SR7304) II (WHT) (SR7304) (SR7304) II (SR7304) (SR7304) (SR7304) II	11-11-74	11-11-74 SR7304
B	BY REV: ADD WIRE LENGTHS, SER OUT G-LA 9 & G-LA 13, SER IN LA 33, LA 34 RED, BLK & WHT, ADD DETAIL 'A', DELETE JUMPER (SR7308) (SR7304) II	12-0-74	12-0-74 SR7308

INACTIVE:  
EFF THRU SER (SR7303) II (SR7304) II  
(SR7308) II (SR7304) II  
10-23-74

RAM  
JST  
P/S  
RF

5060  
04-231-090  
0231-030

WIRE CODE NO.	GA	MATERIAL	LG	TERMINALS	SERIALS
BLK 18	-18-0	12	S-1367-10	S-1367-10	SR7308 BY PHENOLIX AND FR17200940
WHT 18	-18-9	10	S-1635-2	SOLDER	SR7308 BY PHENOLIX AND FR17200940
RED 18	-18-2	10	S-1635-2	SOLDER	SR7308 BY PHENOLIX AND FR17200940
LA 14 18		10	S-1367-10	S-1367-10	THRU SR7308 BY PHENOLIX AND FR17200940
LA 34 18		7	SOLDER	S-1636-2	SR7308 BY PHENOLIX AND FR17200940
LA 33 18		6	SOLDER	S-1636-2	SR7308 BY PHENOLIX AND FR17200940
LA 29 18		14	S-1635-2	S-1367-10	SR7308 BY PHENOLIX AND FR17200940
LA 28 18		10	S-1635-2	S-1636-2	
LA 27 18		7	SOLDER	S-1636-2	
LA 26 18		92	S-1635-2	S-1636-2	
LA 25 18		6	SOLDER	S-1636-2	
LA 13 18		7	S-341-2	SOLDER	THRU SR7308 BY PHENOLIX AND FR17200940
LA 12 18		6	S-341-2	SOLDER	THRU SR7308 BY PHENOLIX AND FR17200940

NOTES:  
1. MODELS APPLICABLE: 172, F172, FR172,

QTY	PART NO.	DESCRIPTION
9	1470089-14	LIGHT ASSEMBLY
8	S-1637-2	HOUSING-PLUG
7	S-1637-1	HOUSING-CAP
6	S-1501-1	SWITCH
5		
4	S-1641-6	HOUSING-SOCKET
3	S-1641-15	HOUSING-SOCKET
2	S-1640-15	HOUSING-PIN
1	S-1360-10	CIRCUIT BREAKER

CONTRACT NO.			WIRE TABLE	
DESIGN	NAME	DATE	SIZE	CODE IDENT NO.
			C	71379
GROUP	Y. W. W.	4-7-70	DWG NO.	0500062
DRAWN	D.G. PLAIN	4-1-70	SCALE:	NONE
CHECK	LX WHITE	4-1-70	PAGE:	11, 13
STRESS				

COMMERCIAL AIRCRAFT DIV.  
5800 E. PAWNEE  
WICHITA, KANSAS

Cessna AIRCRAFT CO.

TITLE  
**WIRING DIAGRAM -  
MAP AND AUXILLARY  
INSTRUMENT LIGHT (OPT)**

EDERR 10939 (SR 6352) II (SR 6353) II (SR 6354) II  
17259224, F17200755  
FR17200226



REV	DATE	BY	APP'D	REVISION
A	3-8-40	JWA	[Signature]	BY REV: ADD FRITZE TO MODEL BLOCK (SEE FRITZE-0001) ON
B	6-18-40	JWA	[Signature]	BY REV: DELETE FRITZE FROM MODEL BLOCK. (SEE FRITZE-0001) ON

- NOTES:
- INSTALL 5-1635-1 PIN ON BLACK WIRE OF COMPASS AND 5-1636-1 SOCKET ON WHITE WIRE OF COMPASS.
  - INSTALL 5-1636-2 SOCKET ON BLACK WIRE OF INSTRUMENT LIGHT.
  - WIRES FURNISHED BY VENDOR
  - ALL WIRE MATERIAL PLS 5-1460

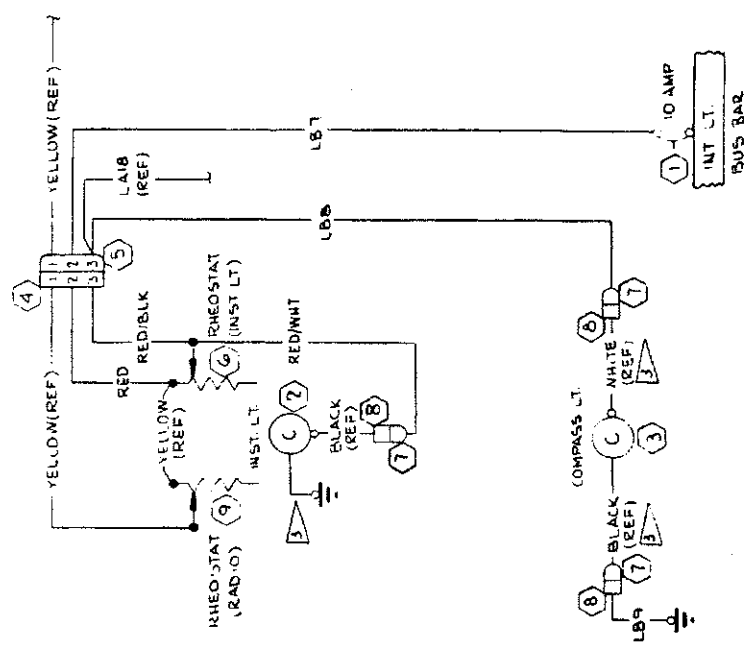

INACTIVE  
REF THRU SEE 11-12-40  
11-12-40  
11-12-40

QTY	DESCRIPTION	UNIT	TERMINALS
1	5-1635-1	PIVOT	
1	5-1635-2	SOCKET	
1	5-1635-3	SOCKET	
1	5-1635-4	SOCKET	
1	5-1635-5	SOCKET	
1	5-1635-6	SOCKET	
1	5-1635-7	SOCKET	
1	5-1635-8	SOCKET	
1	5-1635-9	SOCKET	
1	5-1635-10	SOCKET	

WIRE TABLE	
1	5-1635-1
1	5-1635-2
1	5-1635-3
1	5-1635-4
1	5-1635-5
1	5-1635-6
1	5-1635-7
1	5-1635-8
1	5-1635-9
1	5-1635-10

EQUIPMENT TABLE		
1	041313-5	RHEO-STAT
1	5-1637-2	HOUSING-PLUG
1	5-1635-1	HOUSING-CAP
1	5-1635-2	RHEO-STAT (TR)
1	5-1635-3	HOUSING-CAP
1	5-1635-4	HOUSING-PLUG
1	5-1635-5	COMPASS
1	5-1635-6	INSTRUMENT LT.
1	5-1635-7	CIRCUIT BREAKER
1	5-1635-8	10 AMP INT. LT.

CESSNA AIRCRAFT CO. COMMERCIAL AIRCRAFT DIVISION WICHITA, KANSAS

WIRING DIAGRAM  
COMPASS &  
INSTRUMENT  
LIGHTS

Cessna  
0500062

PAGE 11-12-2 0500062 29-112 112

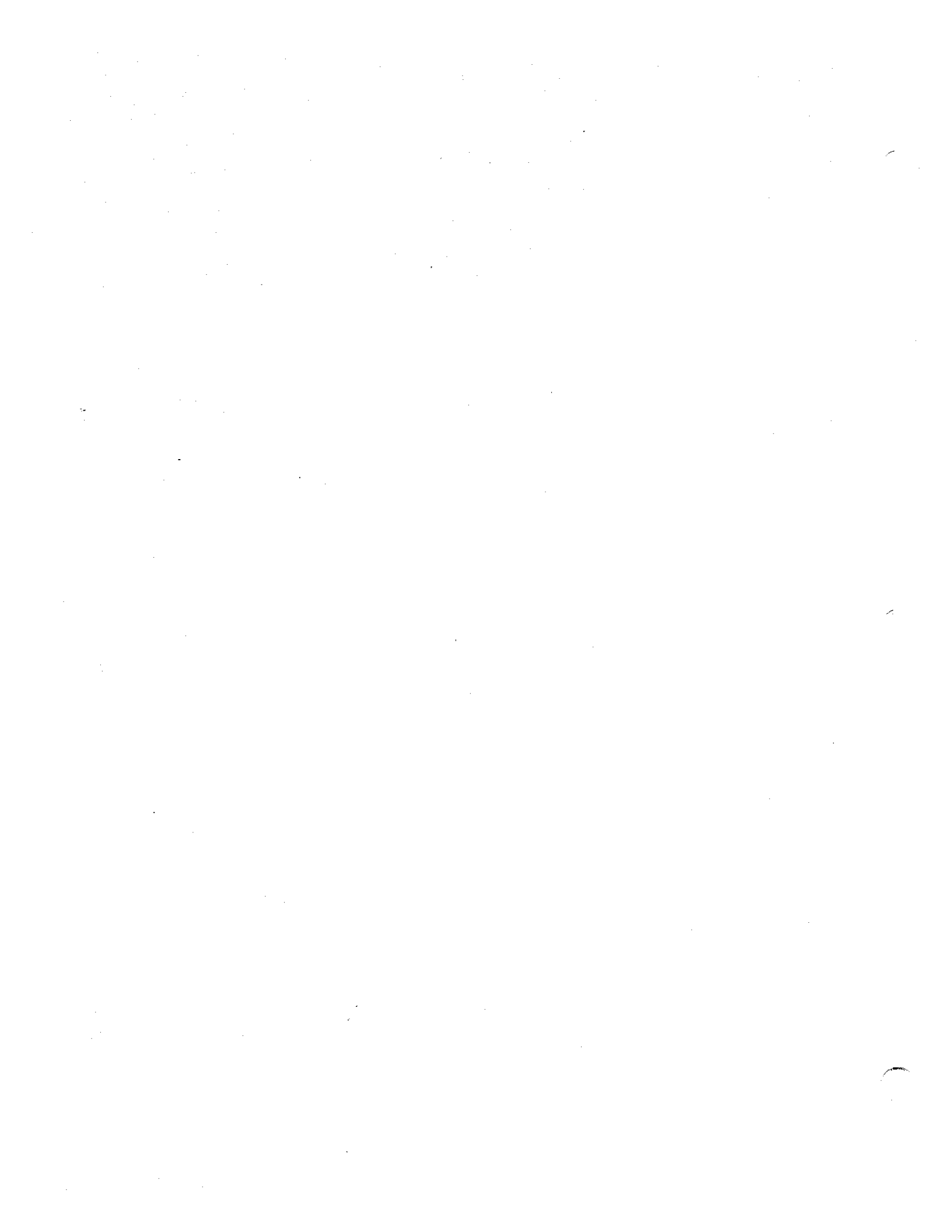



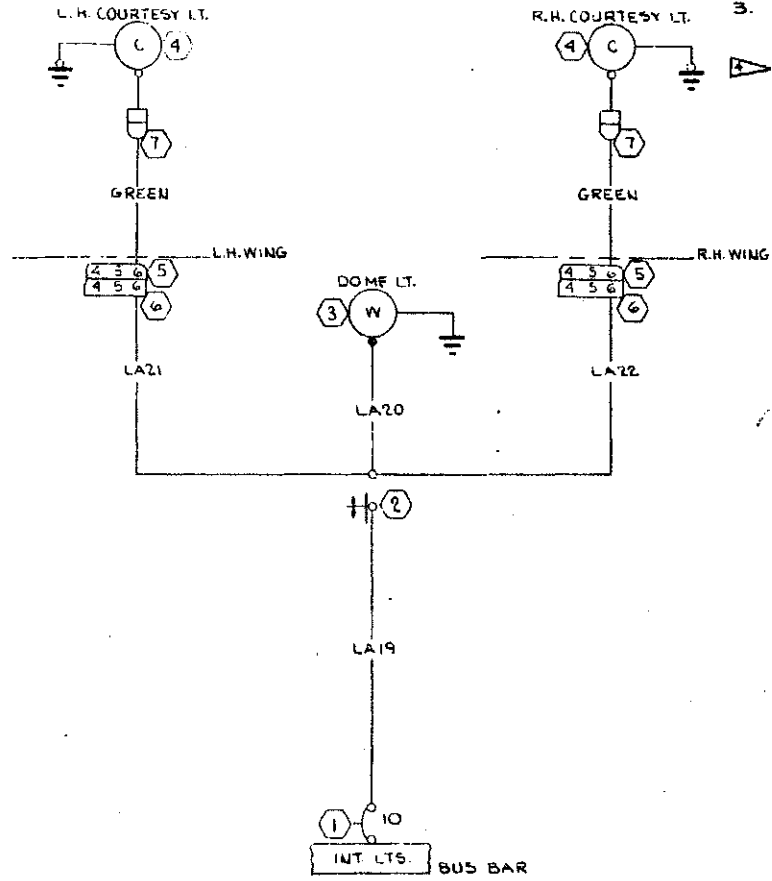

- NOTES:
- 1 WIRE MATERIAL PER S-1460
  - 2 S-1635-2 PIN; S-1631-1 HOUSING-CAP
  - 3 APPLICABLE MODELS; 172, FRITZE, T41-C, 172I
  - 4 COURTESY LIGHTS & ASSOCIATED WIRING ARE NOT APPLICABLE TO THE T41-C.

(SER 17254893) (CON)

REV	REVISION	DATE	BY	CHK
A	BY REV: ADD FRITZE TO MODEL BLOCK (SER FRITZE-0001) (CON)	8-8-67	C.G.	ALL
B	BY REV: ADD NOTES 3 & 4 ED & RR 0013 (SER FRITZE-0001) (CON) (SER FRITZE-0151 THRU-0330)	9-18-67	RCA	ALL
C	BY REV: ADD 172I TO NOTE 3 (FOR 17200192 (SER 17254893))	9-27-67	JSM	ALL

**INACTIVE:**  
 SER 17254893 THRU SER 17259223  
 SER FRITZ-0320 THRU SER FRITZ00754  
 SER FRITZ00001 THRU SER FR 17200225  
 DES 4-1-70  
 J.J.W.  
 R.F.

REV	PART NO.	DESCRIPTION	INSTALLED ON
7	S-1631-1	HOUSING-CAP	
6	S-1641-6	HOUSING-SOCKET	
5	S-1640-6	HOUSING-PIN	
4	0521101-2	COURTESY LIGHT	
3	0511481-6	DOME LIGHT	
2	0T13029	SWITCH	
1	S-1360-10	CIRCUIT BREAKER	

WIRE CODE NO	GA	MATERIAL	LG	TERMINALS	SERIALS
GREEN	18	-18-5	S-1635-2	1	
GREEN	18	-18-5	S-1635-2	2	
LA-12	18		COMMON TO LA 21	S-1636-2	
LA-21	18		LA 21	S-1636-2	
LA-20	18		S-1367-1-6	S-1636-2	
LA-19	18		S-1367-1-6	SOLDER	
LA-19	18		S-1367-1-6	S-1367-1-6	

CESSNA AIRCRAFT CO. COMMERCIAL AIRCRAFT DIVISION, WICHITA, KANSAS

WIRING DIAGRAM - DOME & COURTESY LIGHTS

DATE: 11-3-65  
 DRAWN: BLISS  
 CHECK: J. Wick 12-20-65  
 PART: 20-32-11.7

APPROVED BY: P 11.7.1  
 SUPERVISOR: 0500062 PP 11.7.1  
 MODEL: NOTED  
 REV: C  
 PAGE: 11.7

0500062

Cessna.

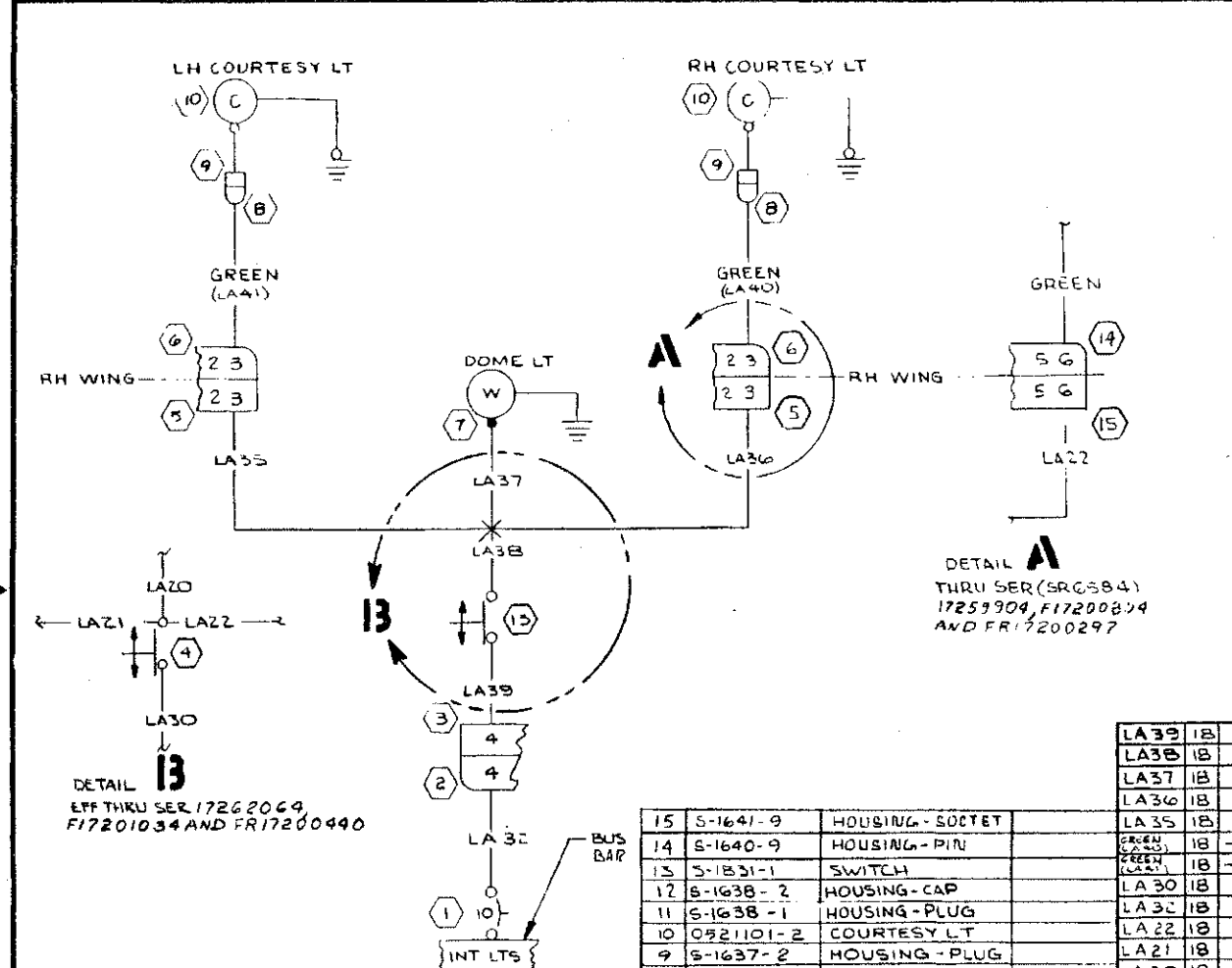

REVISION			
LET	DESCRIPTION	DATE	APPD
A	BY REV. ADD DETAIL A: ADD S-1638-1 (S-1638-2) (S-1638-4)	12-17-70	WRC
B	BY REV: ADD WIRE LENGTHS (NOW SHOP PRACTICE)	3-16-73	JLO N/W LSE
C	BY REV: SET OUT LA20, LA21, LA22 & LA30; SER. IN LA35, LA36, LA37, LA38 & LA39; ADD S-1631-1 & DETAIL 'B', LA40 & LA41 WAS GREEN (SR7630)	7-24-73	JLO N/W LSE
D	BY REV: DELETE NOTE 3: TERM S-1635-1(LA40) WAS S-1635-2, S-1636-1 WAS S-1636-2(LA30), S-1640-6 WAS S-1638-2, S-1641-6 WAS S-1638-2, S-1637-1 WAS S-1637-2, S-1640-9 WAS S-1640-6 & S-1641-9 WAS S-1641-6; PIN GREEN(LA41) WAS 6 (LA35) 6; (172 E0007) (NOW SHOP PRACTICE)	2/8/74	DEF JRS RF

DETAIL A  
THRU SER(SR6584)  
17259904, F17200294  
AND FR 17200297

INACTIVE:  
EFF THRU SER (SR7630) (SR7630)  
RAM  
SER JRS  
RF

DETAIL B  
EFF THRU SER 17262069  
F17201034 AND FR 17200440

- NOTES:
- DASH NUMBER DEPENDS UPON ELECTRONIC CONFIGURATION OF AIRCRAFT
  - 
  - ADD 1/4 INCH HOLE TO COMPASS WIRE
  - APPLICABLE MODELS: 172, F172, FRI72,

PART NO	DESCRIPTION
15	S-1641-9 HOUSING-SOCKET
14	S-1640-9 HOUSING-PIN
13	S-1831-1 SWITCH
12	S-1638-2 HOUSING-CAP
11	S-1638-1 HOUSING-PLUG
10	0321101-2 COURTESY LT
9	S-1637-2 HOUSING-PLUG
8	S-1637-1 HOUSING-CAP
7	0911481 DOME LT ASSY
6	S-1640-6 HOUSING-PIN
5	S-1641-6 HOUSING-SOCKET
4	0713029 SWITCH
3	S-1641-15 HOUSING-SOCKET
2	S-1640-15 HOUSING-PIN
1	S-1360-10 CIRCUIT BREAKER

EQUIPMENT TABLE	
PART NO	DESCRIPTION
	CES-1000 IS APPLICABLE VENDOR CODES PER S-1400 CES-XXXX-CESSNA SPEC. NO. S-XXX OR CMXXXX-CESSNA STD. NO.
	SUPERSEDES P 11.7
	SUPERSEDED BY 0570101 P 11.4.0

LA	IB							
LA39	IB		S-1636-1	S-1830-1				SER 17262065 F17201033 AND FR 17200440
LA38	IB		S-1830-1	S-1870-3				SER 17262065 F17201033 AND FR 17200440
LA37	IB		6	SOLDER	SEE LA38			SER 17262065 F17201033 AND FR 17200440
LA36	IB		45	S-1636-1	SEE LA38			SER 17262065 F17201033 AND FR 17200440
LA35	IB		45	S-1636-1	SEE LA38			SER 17262065 F17201033 AND FR 17200440
GREEN (LA40)	IB	- 18-5	117	S-1635-1	S-1635-1			FR SER 17262064, F17201033 AND FR 17200440
GREEN (LA41)	IB	- 18-5	117	S-1635-1	S-1635-1			FR SER 17262064, F17201033 AND FR 17200440
LA30	IB		94	S-1636-1	S-1367-1-6			FR SER 17262064, F17201033 AND FR 17200440
LA32	IB		74	S-1367-1-6	S-1635-2			FR SER 17262064, F17201033 AND FR 17200440
LA22	IB		45	SEE LA20	S-1636-2			FR SER 17262064, F17201033 AND FR 17200440
LA21	IB		45	SEE LA20	S-1636-2			FR SER 17262064, F17201033 AND FR 17200440
LA20	IB		6	S-1367-2-6	SOLDER			FR SER 17262064, F17201033 AND FR 17200440
WIRE CODE NO	GA	MATERIAL	LG	TERMINALS				SERIALS

CONTRACT NO.		WIRE TABLE		COMMERCIAL AIRCRAFT DIV. 5800 E. PAWNEE WICHITA, KANSAS	
DESIGN	NAME	DATE	TITLE	Cessna, AIRCRAFT CO.	
GROUP	47141	1-2-70	WIRING DIAGRAM - DOME AND COURTESY LIGHTS		
DRAWN	DG PLAIN	3-26-70			
CHECK					
STRESS					
PROJ		6-10-70	SIZE	CODE IDENT NO	DWG NO
APPD			C	71379	0500062
OTHER			SCALE	NONE	NOTED
					PAGE 11.7.1

Change 3 20-33

(SER 1725A893) & ON

NOTES:

- 1. WIRE MATERIAL PER 5-1640
- 2. APPLICABLE MODELS, 172, FRITZE, THRU & 172I

CHG LET	REVISION	BY DATE	CHK APPD
A	BY REV: ADD FRITZE TO MODEL BLOCK (SER FRITZE-000) & ON	C.G. 8-8-67	ALL
B	BY REV: ADD NOTE 2 ED & RR CONT 2 (SER FRITZE-000) & ON (SER FRITZE-025 THRU-020)	RCA 9-18-67	ALL
C	BY REV: ADD 172I TO NOTE 2 (EDR.F00192) (SER 1725A893) & ON	JSM 10-23-67	ALL

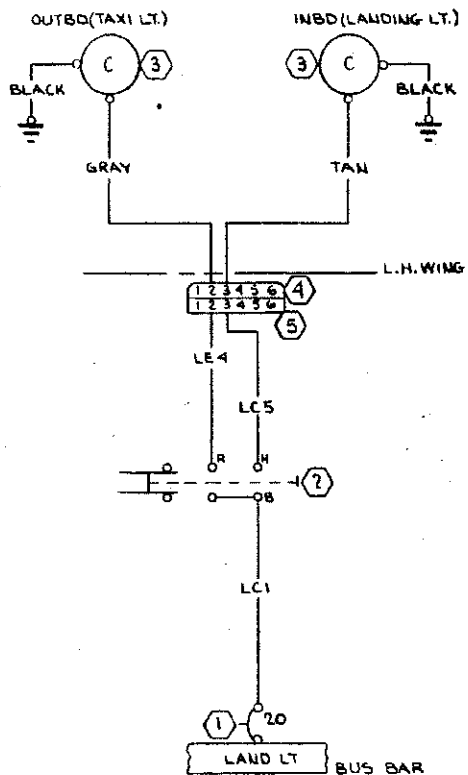

INACTIVE:  
 EFF SER 1725A893 SER 172-0320 SER FRITZE 000  
 THRU SER 17259223 SER FRITZE 00754  
 ED & RR 10-23-67 SER FRITZE 00225 &  
 3-26-70 SER 69-7756

WIRE CODE NO.	GA	MATERIAL	LG	TERMINALS	SERIALS
BLACK	16	-16-0		5-1367-2-8 5-1367-2-8	OPT.
BLACK	16	-16-0		5-1367-2-8 5-1367-2-8	OPT.
GRAY	14	-14-8		5-1635-2 5-1367-2-8	STD.
TAN	14	-14-10		5-1635-2 5-1367-2-8	STD.
LE4	14			5-1367-2-8 5-1636-2	STD.
LCS	14			5-1367-2-8 5-1636-2	STD.
LC1	14			5-1367-2-8 5-1367-2-8	OPT.

PART NO.	DESCRIPTION	INSTALLED ON
5	5-1641-6 HOUSING-SOCKET	
4	5-1640-6 HOUSING-PIN	
3	0523118-1 LIGHT INSTL.	
2	0T13035 SWITCH ASSY	
1	5-1360-20 CIRCUIT BREAKER	

WIRE TABLE

CESSNA AIRCRAFT CO., COMMERCIAL AIRCRAFT DIVISION, WICHITA, KANSAS

DRAWN	BLISS	DATE	11-3-65	<b>WIRING DIAGRAM—</b> <b>LANDING &amp; TAXI</b> <b>LIGHTS</b> <b>(OPTIONAL)</b>	
GROUP	R. N. ...	DATE	12-16-65		
CHECK	C. ...	DATE	12-17-65		
PROJ	...	DATE	12-20-65		
SUPERSEDED BY	P. 11. B. 1	SUPERSERIES	0500062 2P11.3	MODEL	NOTED
REV:	C	PAGE:	11.8	DWG NO: <b>0500062</b>	

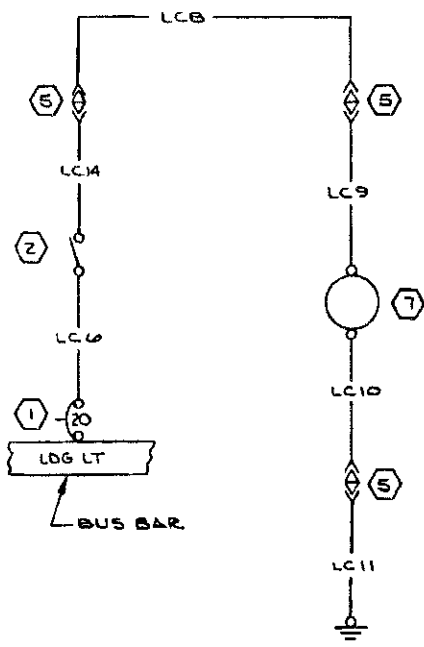

REVISION			
LET	DESCRIPTION	DATE	APPD
A	BY REV: 4522 WAS 4527; PIN 6 WAS PIN 2 / S-1640-15 & S-1641-15; S-2061-1 WAS S-1824-1 EDARR 10088 (SR6552) II	RLY 5-11-70	LW RLY N/W RF
B	BY REV: DELETE S-1637-1 & S-1637-2; ADD S-2064-1; S-1360-20 WAS S-1360-10, S-1493-2 WAS S-1635-2 & S-1636-2 / LCB, LC9, LC10 & LC11, 12 GA WAS 14 GA, S-1493-3 WAS S-1493-2 & S-1367-3-X WAS S-1367-2-X; DELETE S-1640-15 & S-1641-15 LC14 WAS LC7 ED & ER 10086 & 10098 (SR6552) II	RLY 7-16-70	LW RLY N/W RF
C	BY REV: SER OUT S-2061-1 & SER IN S-2160-5 (SR 7303) II	JCY 2-28-73	NEW N/W RF
D	BY REV: S-1367-3-12 WAS S-1367-3-6 PER LC11, ADD WIRE LENGTHS (NOW SHOP PRACTICE)	JLO 3-16-73	NEW N/W RF
E	BY REV: DELETE S-2160-5 & INACT. DWG (SR7303) II	RAM 7-5-73	BY NEW RF

INACTIVE  
EFF THRU SER 7261898  
RAM  
RF  
AND FIT 201034  
7-5-73

ITEM NO	QTY	DESCRIPTION	WIRE CODE NO	MATERIAL	LG	TERMINALS	SERIALS
LC11	12	35 S-1493-3 S-1367-3-12					
LC10	12	60 S-1367-3 S-1493-3					
LC9	12	60 S-1493-3 S-1367-3-6					
LC8	12	70 S-1493-3 S-1493-3					
LC14	12	9 S-1493-3 S-1493-3					
LC6	12	12 S-1367-3 S-1493-3					

ITEM NO	PART NO.	DESCRIPTION	VENDOR
7	4522	LAMP	(24446)
6			
5	S-2064-1	CONNECTOR	
4			
3			
2	S-2061-1	SWITCH	
1	S-1360-20	CIRCUIT BREAKER	

CONTRACT NO:		NAME		DATE	COMMERCIAL AIRCRAFT DIV. 8900 E. PAWNEE WICHITA, KANSAS		
DESIGN	WJ COOLIC	1-22-70	TITLE		Cessna AIRCRAFT CO.		
GROUP	R. W. HALL	1-22-70	WIRING DIAGRAM -				
DRAWN	R. YOUNGERS	1-21-70	LANDING LIGHT				
CHECK	WARRIS	1-21-70	SIZE	CODE IDENT NO.	DWG NO.		
STRESS			C	71379	0500062		
PROJ	R. J. K.	1-23-70	SCALE	NONE	17ZL	PAGE: 11 OF 1	
APPD	R. YOUNGERS	1-22-70					
OTHER							

EQUIPMENT TABLE	SUPERSEDES:
CES-1000 IS APPLICABLE VENDOR CODES PER S-1400 CES-XXXX-CESSNA SPEC. NO. S-XXX OR CMXXXX-CESSNA STD. NO.	SUPERSEDED BY: P 11.18.3

Change 2 20-35

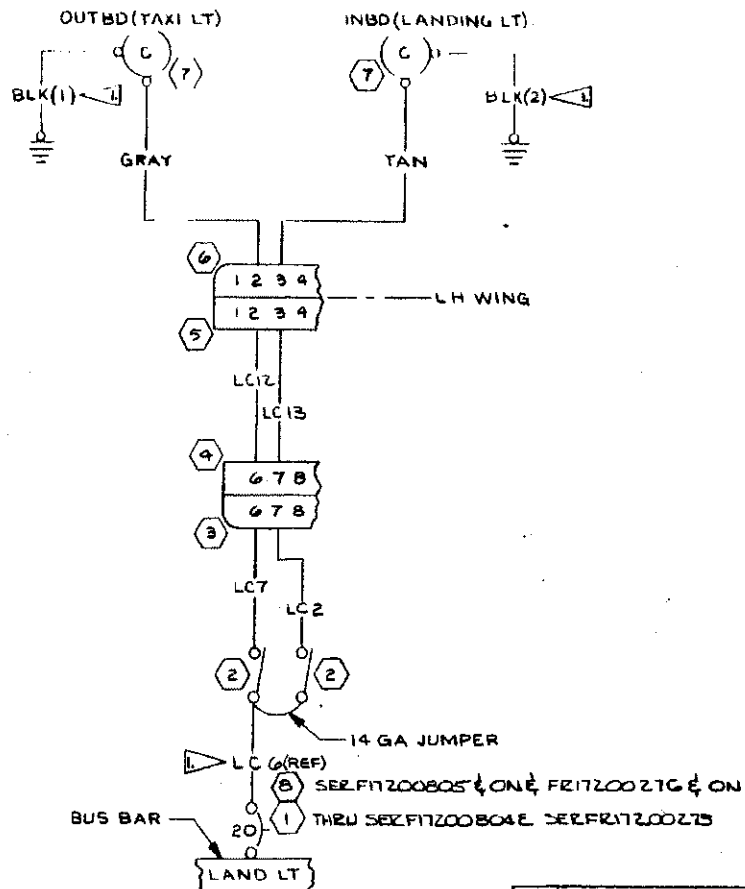

NOTES:

- ▶ THESE WIRES OPTIONAL ALL OTHERS ARE STANDARD EQUIPMENT
- 2 APPLICABLE MODELS: F172, F172

ITEM NO	PART NO.	DESCRIPTION
8	S-1360-20L	CIRCUIT BREAKER
7	052311B-1	LIGHT INSTL
6	S-1640-6	HOUSING-PIN
5	S-1641-6	HOUSING-SOCKET
4	S-1641-15	HOUSING-SOCKET
3	S-1640-15	HOUSING-PIN
2	S-1824-1	SWITCH
1	S-1360-20	CIRCUIT BREAKER

CES-1000 IS APPLICABLE  
 VENDOR CODES PER S-1400  
 CES-XXXX-CESSNA SPEC. NO.  
 S-XXX OR CMXXXX-CESSNA  
 STD. NO.

SUPERSEDES:  
 P 11. B  
 SUPERSEDED BY:  
 P 11. B.3

WIRE CODE NO	GA	MATERIAL	LG	TERMINALS	SERIALS
BLK(A)	16	-16-0	6	S-1367-2-B	S-1367-2-B
BLK(I)	16	-16-0	6	S-1367-2-B	S-1367-2-B
TAN	14	-14-B	130	S-1635-2	S-1367-2-B
GRY	14	-14-10	130	S-1635-2	S-1367-2-B
LC13	14			S-1636-2	S-1636-2
LC12	14			S-1636-2	S-1636-2
LC7	14			S-1493-2	S-1635-2
LC2	14			S-1493-2	S-1635-2

CONTRACT NO: \_\_\_\_\_

DESIGN: \_\_\_\_\_ NAME: \_\_\_\_\_ DATE: \_\_\_\_\_

GROUP: *W. J. ...* 4-2-70

DRAWN: D.G. PLAIN 3-26-70

CHECK: L. WHITE 4-1-70

STRESS: \_\_\_\_\_

PROJ: *R. J. ...* 4-15-70

APPD: R. J. ... 4-1-70

OTHER: \_\_\_\_\_

WIRE TABLE

CESSNA AIRCRAFT CO. COMMERCIAL AIRCRAFT DIV. 5800 E. PAWNEE WICHITA, KANSAS

TITLE: **WIRING DIAGRAM - LANDING TAXI LIGHTS (OPTIONAL)**

SIZE: **C** CODE IDENT. NO: **71379** DWG NO: **0500062**

SCALE: NONE NOTED PAGE: 11. B.2

REV	DESCRIPTION	DATE	BY
A	BY REV: ADD S-1360-20L & SER; SER OUT S-1360-20; INACT DWG (SER 1316)	9-21-72	RCA
B	BY REV: LCG(REF) WAS LCG, ADD WIRE LENGTHS (NOW SHOP PRACTICE)	3-16-73	BY NAW RF

INACTIVE:  
 EFF TABU SER F1721034 & F1720490  
 9-21-72  
 RCA  
 BY NAW  
 RF





NOTES

- 1. THIS DIAGRAM APPLICABLE TO FR172 E, FITZ AS STANDARD OPTION E TO 112 AS AN ALT OPTION
- 2. REFER TO PAGE 11.11 FOR WIRE / JUMP FOR SINGLE LAMP STANDARD OPTION FOR DOMESTIC 172
- 3. THESE WIRES SHALL BE FABRICATED FROM COLOR CODED MATERIAL
- 4. THESE ITEMS REQUIRED ONLY AS PART OF THE ALTERNATE OPTION ON THE DOMESTIC 172

REVISION			
LET	DESCRIPTION	DATE	APPD
A	BY REV. SER OUT S-2001-1 & SER IN S-2160-4 (SR7303) SR7304	JCT 1-18-73	H/W
B	BY REV. ADD LC21, LC6 & NOTE 4 & S-1493-3/LC20 WAS S-1367-3-6 12GA. JUMPER (SR7303)	7-5-73	H/W

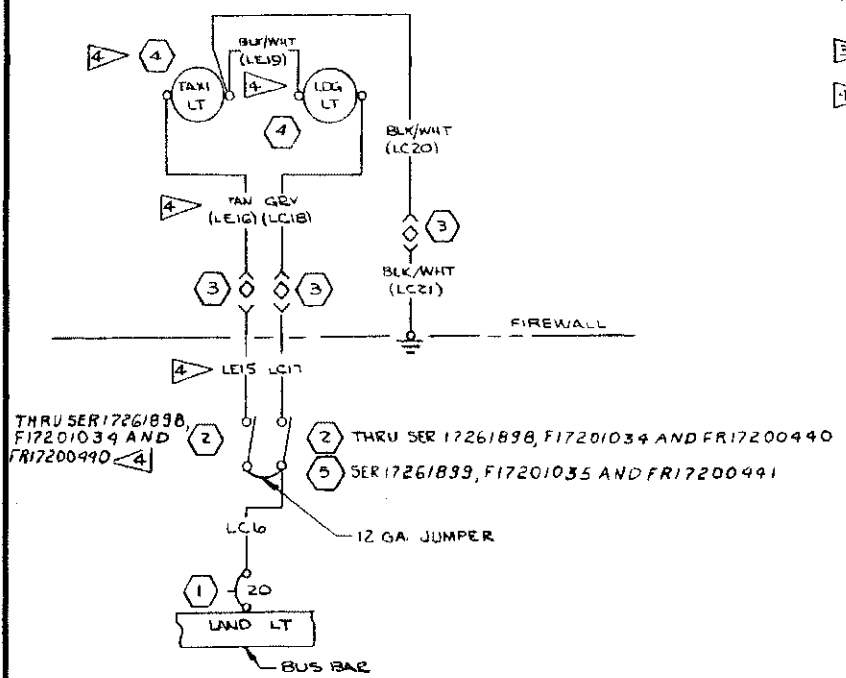

THRU SER 17261898, F17201034 AND FR17200440  
 THRU SER 17261898, F17201035 AND FR17200441

INACTIVE  
 EFF THRU SER (SR7303) (SR7304)  
 (SR7303) (SR7304)  
 10-29-72  
 RAM  
 JCT  
 PMS

03-21-0005  
 03-21-0005

WIRE CODE NO	GA	MATERIAL	LG	TERMINALS	SERIALS
LC6	12			S-1367-3-6	S-1493-3
BLK/WHT (LC21)	12			S-1493-3	S-1367-3-6
BLK/WHT (LC20)	12			S-1367-3-6	S-1493-3
BLK/WHT (LE19)	12			S-1367-3-8	S-1367-3-8
GRV (LE16) (LC18)	12			S-1493-3	S-1367-3-8
LC17	12			S-1493-3	S-1493-3
TAN GRV (LE16)	12			S-1493-3	S-1367-3-8
LE15	12			S-1493-3	S-1493-3

PART NO.	DESCRIPTION	VENDOR
5	S-2160-4 SWITCH	
4	4509 LAMP	Z4446
3	S-2001-1 CONNECTOR	
2	S-2001-1 SWITCH	
1	S-1360-20L CIRCUIT BRK	

CONTRACT NO:		COMMERCIAL AIRCRAFT DIV. 5800 E. PAWNEE WICHITA, KANSAS	
DESIGN	NAME	DATE	<b>Cessna AIRCRAFT CO.</b> TITLE <b>WIRING DIAGRAM —          LANDING &amp; TAXI LIGHT          (OPT)</b>
GROUP	H. Will	10/10/72	
DRAWN	RCAITELL	8-27-72	
CHECK	E. YOUNGERS	8-27-72	
STRESS			
PROJ	KJ	11/7/72	SIZE <b>C</b>
APPD			CODE IDENT NO. <b>71379</b>
OTHER			DWG NO. <b>0500062</b>
SCALE: NONE		(SR7316)	PAGE: 11.8.3

CES-1000 IS APPLICABLE  
 VENDOR CODES PER S-1400  
 CES-XXXX-CESSNA SPEC. NO.  
 S-XXX OR CMXXXX-CESSNA  
 STD. NO.

SUPERSEDES:  
 0500062 PG 11.8.2  
 SUPERSEDED BY: P 11.5.0  
 0570101 P 11.5.1

(FR17200441)

Change 3 20-36A/(20-36B blank)





(SER 7254893) & ON

NOTES:  
1 WIRE MATERIAL PER S-1460

2 APPLICABLE MODELS; 172, FRITZE, T41-C & 172I

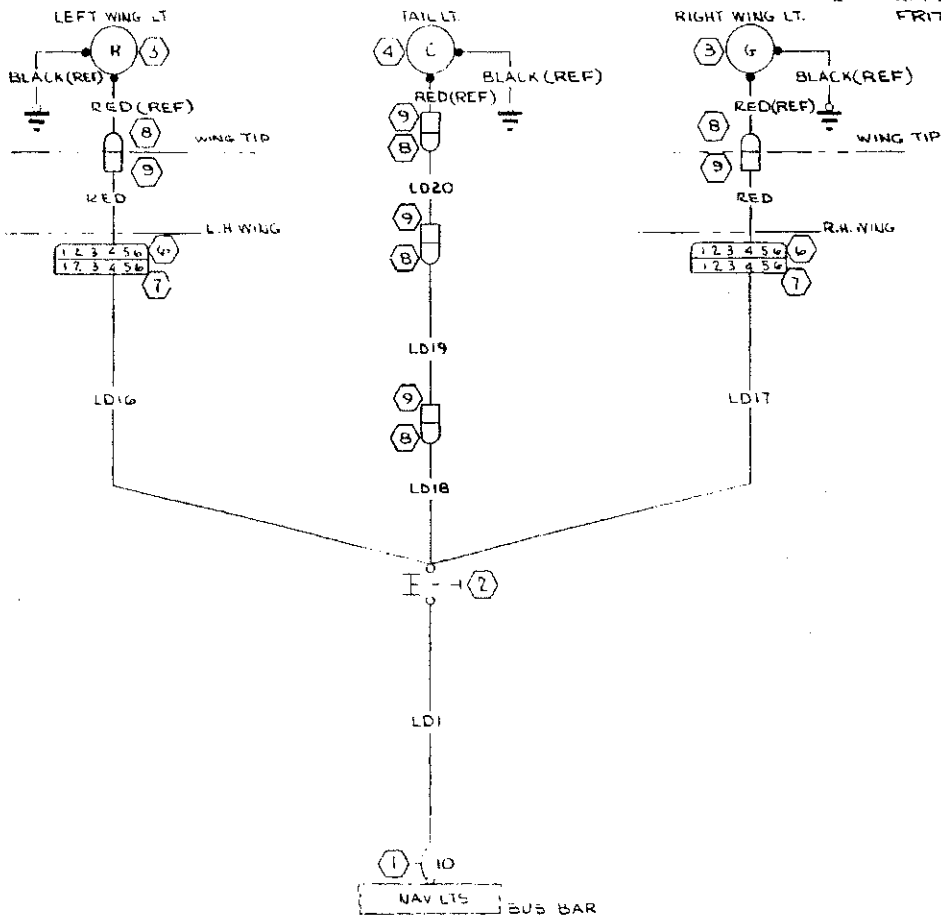

CHG LEFT	REVISION	BY	CHK	DATE	APPD
A	ADD 17 RED WIRES IN WING TIPS 5 ITEMS 84, 8, 9, 10, 11, 12, 13, 14, 15, 16, 17, 18, 19, 20 ON RED WIRES WERE GOLDEN	J.A.	W.L.	12-24-67	W.L.
B	BY REV: ADD FRITZE TO MODEL BLOCK (SER FRITZE-0001) & ON	C.G.	RCA	8-8-67	W.L.
C	BY REV: ADD NOTE 2 EDERR001736ER FRITZE-0001 0257 THRU-0301 (FRITZE-0001) & ON	RCA	W.L.	9-18-67	W.L.
D	BY REV: ADD 172I TO NOTE 2 (EDRR00192) & ON BY REV: C622001-0202 WAS 0423006-21E-22, C622001- 0102 WAS 0433006-7 ITEM 3 WAS ITEMS 4 LD18 WAS LD11, LD19 WAS LD6, LD20 WAS LD7; ADD S1460-182 DELETE 3 RED & 3 BLACK WIRES (EDRR01163) (EDRR01339)	JSM	W.L.	9-27-67	W.L.
E		RCC	W.L.	1-6-67	W.L.

INACTIVE:  
 SER FR172-0320 THRU SER FR17200754  
 SER FR17254893 THRU SER FR172592223  
 SER FR172E0001 THRU SER FR17200225  
 EDERR 10939  
 DOP 3-26-70  
 W.L.  
 W.L.  
 W.L.

WIRE	GA	MATERIAL	TERMINATION	SERIALS
LD20	18		S-1636-1	S-1635-1
LD19	18		S-1636-1	S-1635-1
LD18	18		SOLDER	S-1635-1
RED	18	-18-2	S-1635-2	S-1635-2
RED	18	-18-2	S-1635-2	S-1635-2
LD17	18		S-361-3	S-341-2
LD16	18		S-361-3	S-341-2
LD11	18	THRU SER(SR5631) 26	S-361-3	S-341-2
LD7	18	THRU SER(SR5631) 84	S-341-2	SOLDER
LD6	18	THRU SER(SR5631) 290	S-341-2	S-341-2
LD1	8		S-361-3	S-361-3

QTY	PART NO	DESCRIPTION	INSTALLED ON
9	S-1637-2	HOUSING - PLUG	
8	S-1637-1	HOUSING - CAP	
7	S-1641-6	HOUSING - SOCKET	
6	S-1640-6	HOUSING - PIN	
2	C622001-0102	TAIL LIGHT	
3	C622001-0202	WING LIGHT	
7	011307-6-4	SWITCH ASST	
1	S-1360-10	CIRCUIT BREAKER	

WIRE TABLE			
NO	DATE	BY	CHK
1	12-24-67	J.A.	W.L.
2	8-8-67	C.G.	RCA
3	9-18-67	RCA	W.L.
4	9-27-67	JSM	W.L.
5	1-6-67	RCC	W.L.

CESSNA AIRCRAFT CO., COMMERCIAL AIRCRAFT DIVISION, WICHITA, KANSAS

WIRING DIAGRAM - WING & TAIL LIGHTS	Cessna
REV: E	PAGE: 119

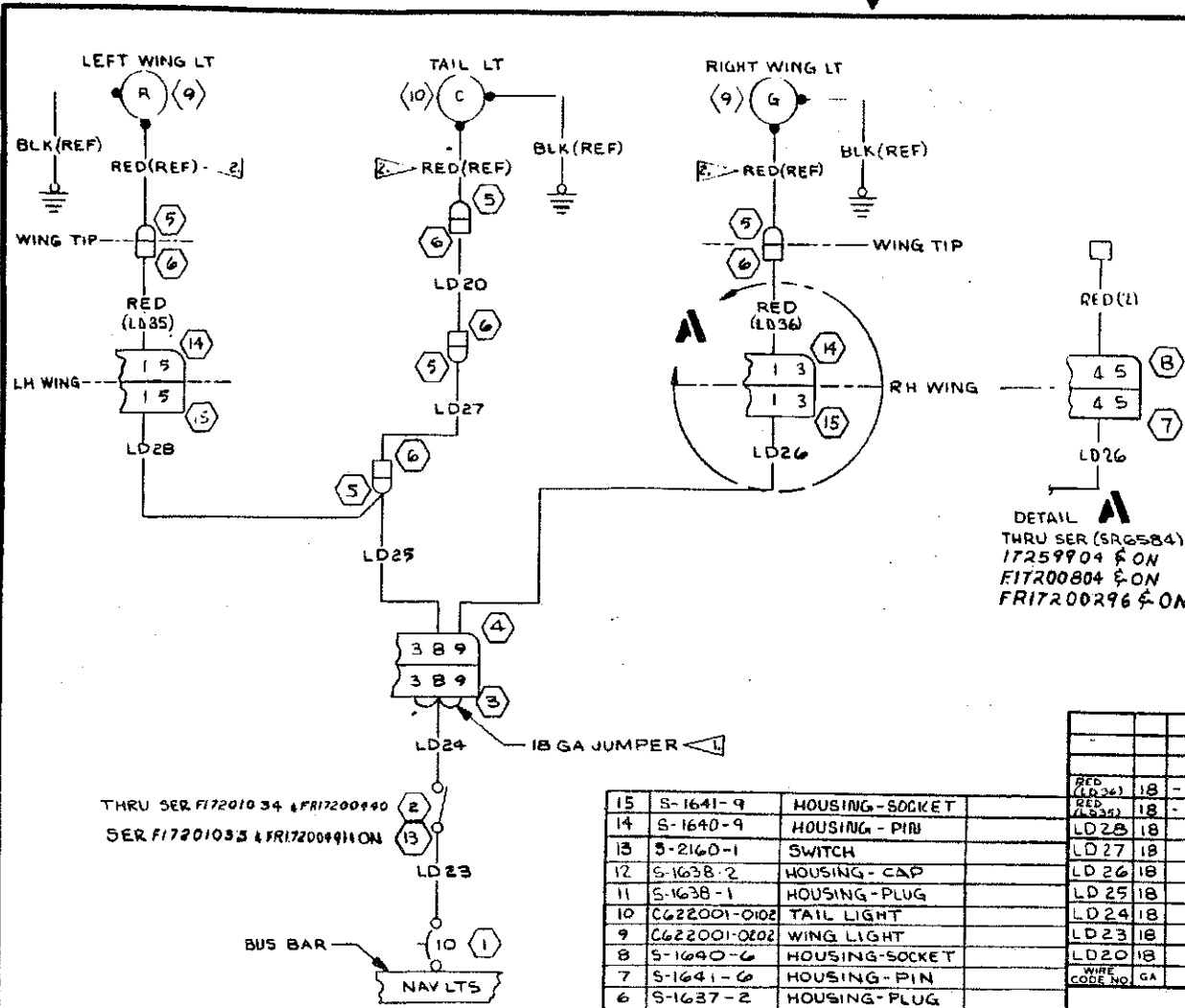

THRU SER F17201034 & F17200440  
SER F17201033 & F17200441 ON

- NOTES:**
- ▶ JUMPER WIRES TERMINATE WITH S-1635-2
  - ▶ ADD S-1637-1 CAP TO VENDOR FURNISHED RED WIRE
  - 3 APPLICABLE MODELS: 172, F172, FRI72,

PART NO.	DESCRIPTION
15	S-1641-9 HOUSING-SOCKET
14	S-1640-9 HOUSING-PIN
13	S-2160-1 SWITCH
12	S-1638-2 HOUSING-CAP
11	S-1638-1 HOUSING-PLUG
10	C622001-0102 TAIL LIGHT
9	C622001-0202 WING LIGHT
8	S-1640-6 HOUSING-SOCKET
7	S-1641-6 HOUSING-PIN
6	S-1637-2 HOUSING-PLUG
5	S-1637-1 HOUSING-CAP
4	S-1640-15 HOUSING-SOCKET
3	S-1641-15 HOUSING-PIN
2	S-1824-1 SWITCH
1	S-1360-10 CIRCUIT BREAKER

EQUIPMENT TABLE	
PART NO.	DESCRIPTION
CES-1000	IS APPLICABLE
VENDOR CODES	PER S-1400
CES-XXX	OR CESSNA SPEC. NO.
S-XXX	OR CMXXX
CESNA	STD. NO.

SUPERSEDES: P 11.9  
SUPERSEDED BY: 0570101 P 11.6.0

DETAIL A  
THRU SER (SR6584)  
17259904 & ON  
F17200804 & ON  
FRI7200296 & ON

REV	DESCRIPTION	DATE	APPL
A	BY REV: ADD WIRE LENGTHS (NOW SHOP PRACTICE)	WJK 12-1-70	
B	BY REV: S-1640-15 WAS S-1641-15; S-1641-15 WAS S-1640-15 (NOW SHOP PRACTICE)	10-5-72 RCA	BY XAW DMM WJ
C	BY REV: SER OUT S-1824-1 SER IN S-2160-1 (SR 1303) (SR 7304) II	JCY 2-28-73	BY XAW DMM WJ
D	BY REV: ADD WIRE LENGTHS (NOW SHOP PRACTICE)	JLO 3-16-73	BY XAW DMM WJ
E	BY REV: S-1636-1/LD20 WAS S-1635-1 (NOW SHOP PRACTICE)	JLO 10-11-73	BY XAW DMM WJ
F	BY REV: RED (LD35) WAS RED(2) RED (LD35) WAS REM(1); S-1636-1(LD36) (LD35)(LD28)(LD26)(LD24) WAS S-1636-2; S-1635-1(LD36)(LD35)(LD26)(LD25) WAS S-1635-2; S-1640-9 WAS S-1638-1 & S-1640-15; S-1641-9 WAS S-1638-1 & S-1640-15; (172 E0007) (NOW SHOP PRACTICE)	JEF 2-8-74	BY XAW DMM WJ
G	BY REV: SEE LD25 WAS SEE LD27/LD 28 (NOW SHOP PRACTICE) (MER 172 E0035)	MEM 5-9-74	BY XAW DMM WJ

INACTIVE:  
EFF THRU SER (SR1800) (SR1800) 10-28-74  
RAM  
JCY  
JRS  
WJ

S060-152-50  
04-24-70

WIRE CODE NO.	GA	MATERIAL	LG	TERMINALS	SERIALS
RED (LD36)	18	-18-2	200	S-1635-1	S-1636-1
RED (LD35)	18	-18-2	200	S-1635-1	S-1636-1
LD28	18		43	SEE LD25	S-1636-1
LD27	18		290	S-1636-1	S-1635-1
LD26	18		74	S-1635-1	S-1636-1
LD25	18		38	S-1635-3	S-1635-1
LD24	18		7	S-1493-1	S-1636-1
LD23	18		10	S-1367-1-6	S-1493-1
LD20	18		75	S-1636-1	S-1636-1

CONTRACT NO.			COMMERCIAL AIRCRAFT DIV. Cessna, AIRCRAFT CO. 5800 E. PAWNEE WICHITA, KANSAS	
DESIGN	NAME	DATE	TITLE	
GROUP	4 Wing	4-2-70	WIRING DIAGRAM -- WING & TAIL LIGHTS	
DRAWN	DG. PLAIN	7-26-70		
CHECK	LK WILITE	9-1-70		
STRESS				
PROJ	4-10-70	SIZE	CODE IDENT NO.	DWG NO.
APPO	2-10-70	C	71379	0500062
OTHER		SCALE	NONE	NOTED
		PAGE	11.9.1	

EDIR 10139 (SR 6352) (SR 6353) (SR 6354) II  
(17259224; F17200756) (FRI7200226)

NOTES:

(SER 17254893) (CON)

1. APPLICABLE MODELS; 172 FRITZE 172I.

REV	REVISION	BY	DATE	CHK
A	BY REV: ADD FRITZE TO MODEL BLOCK (SER FRITZE - 0001) (SER 17254893)	CG	8-6-67	W
B	BY REV: ADD NOTE 1 ED & RR 0017 (SER 17254893) -0257 THRU -0304 (FRITZE - 0001)	RCA	8-15-67	W
C	BY REV: ADD 172I TO NOTE 1. (ED & RR 0017) (SER 17254893) -0257 THRU -0304 (FRITZE - 0001)	JSM	9-27-67	W
D	BY REV: DELETE MODEL T41-C FROM NOTE 1. (ED & RR 0182) (SER 17254893)	JWH	11-17-67	W
E	BY REV: ADD DETAIL A & B C594501-0203; SER IN C594501-0201 & C621001-0103; SER OUT C594501-0101, -0201 & C621001-0101 ED & RR 10537 (SA 6224); (SA 5307) (SA 5412)	PGF	12-26-68	W
F	BY REV: ADD DETAIL C, LF11, LF12 & IR-075-11.5; (SER 17254893) WAS YEL (REF) / PIN 2 ED & RR 10550 (SA 6224)	ELY	1-17-70	W
G	BY REV: C621001-0106 WAS C621001-0103	DLP	1-17-73	W

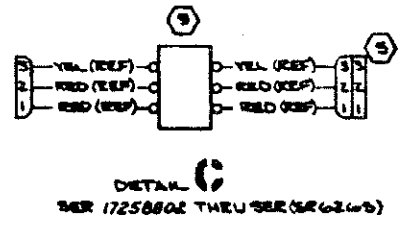
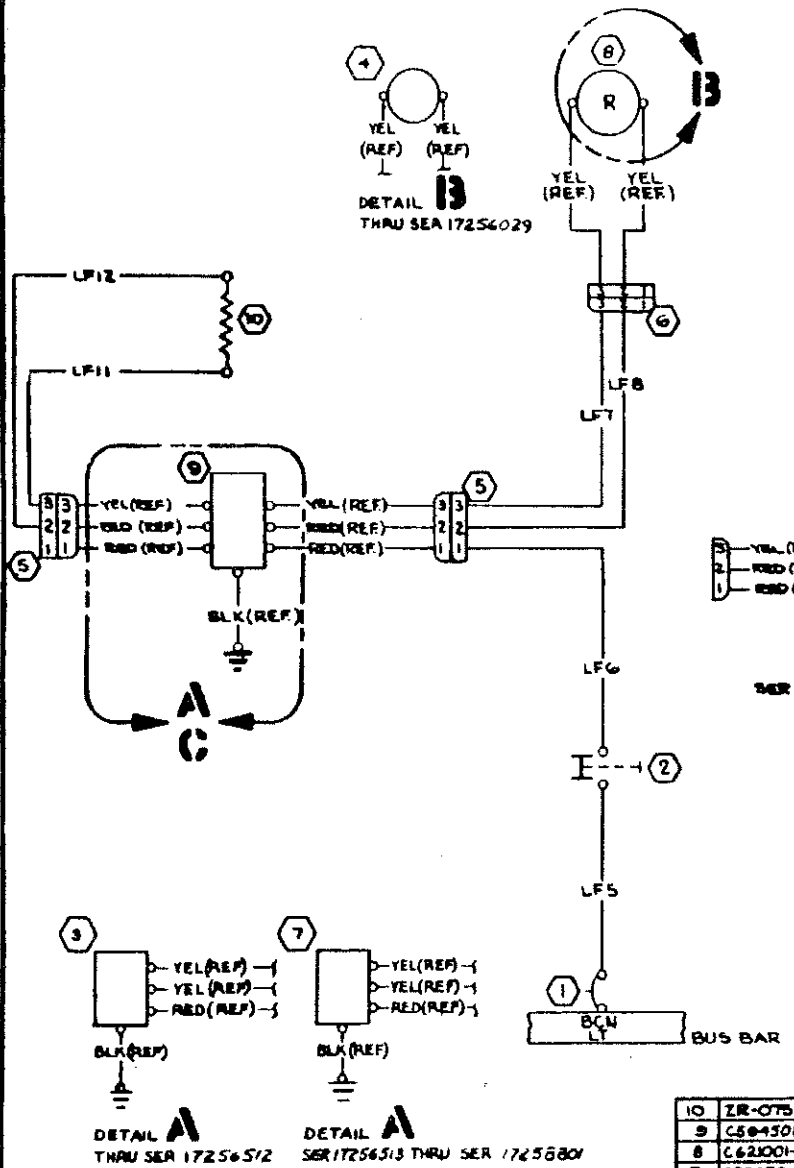

DETAIL C  
SER 17258802 THRU SER 17258803

INACTIVE:  
EFF SER 17254893, FRITZE-0001 & F172-0320  
THRU SER 17259223, FR17200225, F17200754  
ELY 4-3-70  
BY XFW/W

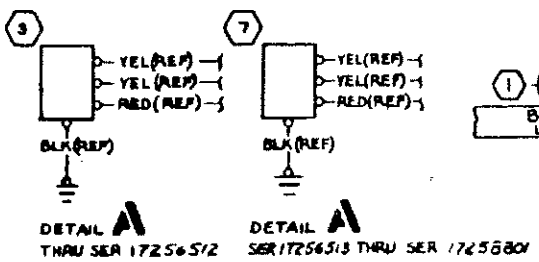

DETAIL A  
THRU SER 17256512

DETAIL A  
SER 17256513 THRU SER 17256801

PART NO.	DESCRIPTION	INSTALLED ON
10	IR-075-11.5 RESISTOR (55717)	
9	C594501-0203 FLASHER ASSY	
8	C621001-0106 LIGHT ASSY	
7	C594501-0201 FLASHER ASSY - MV	
6	S-163B-2 HOUSING-CAP	
5	S-163B-1 HOUSING-PLUG	
4	C621001-0101 LIGHT ASSY - MV	
3	C594501-0101 FLASHER ASSY - MV	
2	0T13026-4 SWITCH ASSY	
1	S-136010 CIRCUIT BREAKER	

EQUIPMENT TABLE

WIRE CODE NO.	GA	MATERIAL	LG	FORM/VAL	REMARKS
LF12	16	S-1636-2	S-1495-2		SER 17254893 (CON)
LF11	16	S-1636-2	S-1495-2		SER 17254893 (CON)
LF8	16	S-1636-2	S-1635-2	STD.	
LF7	16	S-1636-2	S-1635-2	STD.	
LF6	16	S-1636-2	S-1635-2	STD.	
LF5	16	S-1617-6	S-1561-2B	OPT.	

WIRE TABLE

WIRING DIAGRAM - LIGHT FLASHING BEACON (OPTIONAL)

DATE: 12-2-65

BY: [Signature]

CHKD: [Signature]

APP'D: [Signature]

PROJECT: 0500062

MODEL: G

PAGE: 11-10

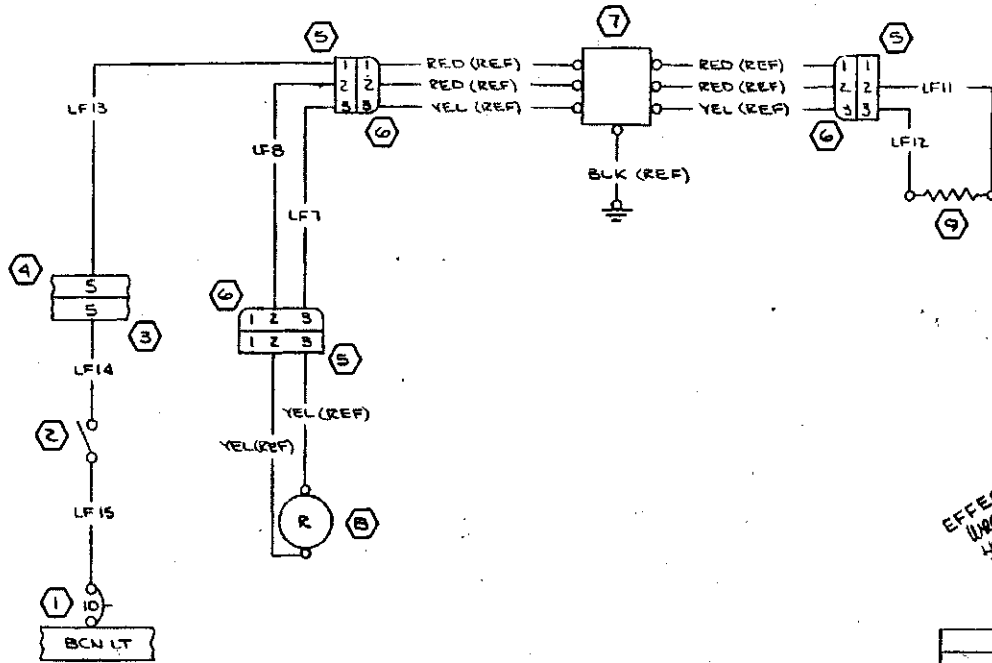

REVISION			
LET	DESCRIPTION	DATE	APPD
A	BY REV: C621001-0106 WAS C621001-0103	BLP 1-17-73	BY N/A RF
B	BY REV: ADD WIRE LENGTHS (NOW SHOP PRACTICE)	DLO 3-16-73	BY N/A RF

**INACTIVE**  
 EFFECTIVE SER'S 17259224, F17200T55 & F17200226 THRU SER. 17260759, F172003041  
 W/REV 6-16-72  
 BY N/A RF

NOTES:

1. APPLICABLE MODELS: 172L, F172K, F172H.

PART NO.	DESCRIPTION	QUANTITY	WIRE CODE NO.	MATERIAL	LG	TERMINALS	SERIALS
9	ZR-015-11.5 RESISTOR (83777)	1	GA				
B	C621001-0106 LIGHT ASSY	1					
7	C694501-0103 FLASHER	1					
6	S-1638-2 HOUSING-CAP	1					
5	S-1638-1 HOUSING-PLUG	1					
4	S-1641-15 HOUSING-SOCKET	1					
3	S-1640-15 HOUSING-PIN	1					
2	S-1824-1 SWITCH	1					
1	S-1360-10 CIRCUIT BREAKER	1					

WIRE TABLE			
WIRE CODE NO.	MATERIAL	LG	TERMINALS
LF15	16	10	S-1493-2 S-1361-2B
LF1A	16	8	S-1635-2 S-1493-2
LF13	16	290	S-1636-2 S-1636-2
LF12	16	8	S-1636-2 S-1493-2
LF11	16	8	S-1636-2 S-1493-2
LF8	16	69	S-1636-2 S-1635-2
LF7	16	69	S-1636-1 S-1635-2

CONTRACT NO:		COMMERCIAL AIRCRAFT DIV. 8800 E. PAWNEE WICHITA, KANSAS	
DESIGN	NAME	DATE	TITLE
GROUP	R. Youngers	4-10-70	WIRING DIAGRAM - FLASHING BEACON (OPTIONAL)
DRAWN	R. Youngers	4-3-70	
CHECK	LK White	4-15-70	
STRESS			
PROJECT	R. Youngers	4-13-70	SIZE
APPD	R. Youngers	4-3-70	CODE IDENT. NO.
			DWG NO.
			C 71379 0500062
			SCALE: NONE
			PAGE: 11.10.1

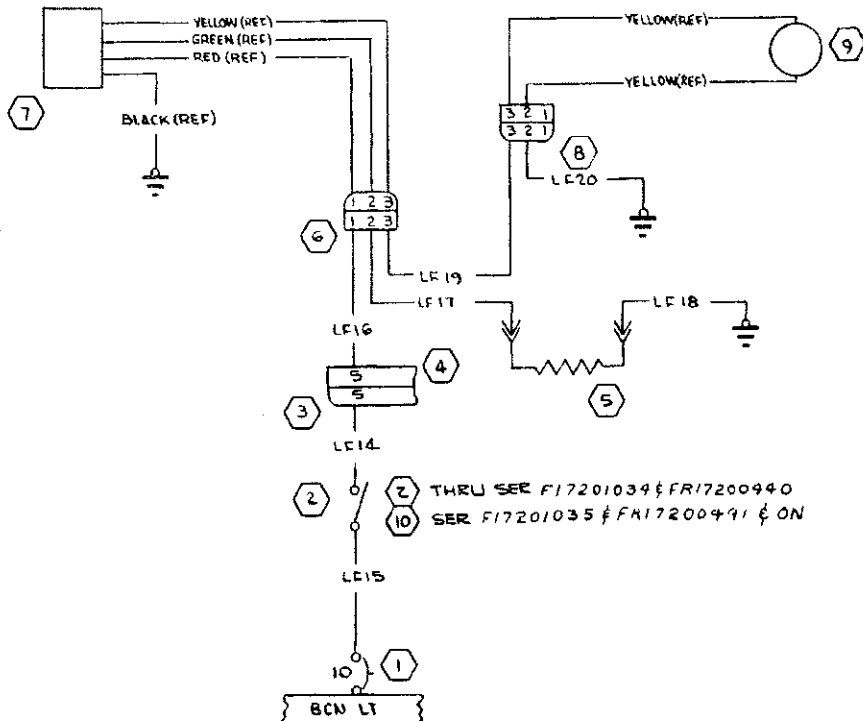

REVISION			
LET	DESCRIPTION	DATE	APPD
A	BY REV: ADD S-2160-1 RESER; SER OUT S-1824-1; CG21001-0106 WAS CG21001-0103 (SERT303) & (SERT304) II	DLP 1-10-73	BY MLW RF
B	BY REV: S-1367-2-B WAS S-1367-2-6 PER LF20, ADD WIRE LENGTHS (NON SHOP PRACTICE)	JLO 4-9-73	BY MLW RF

INACTIVE:  
 EFF THRU SER (SERT303) & (SERT304) II  
 RAM  
 JUL 1974  
 JAS RF  
 (17263589) (17201389)  
 10-73-14

1060-112-80  
 03-12-73

PART NO.	DESCRIPTION
10	S-2160-1 SWITCH
9	CG21001-0106 LIGHT ASSY
8	S-1638-2 HOUSING-CAP
7	CS94502-0101 FLASHER ASSY
6	S-1638-1 HOUSING-PLUG
5	OR95-1.5 RESISTOR (B37TT)
4	S-1641-15 HOUSING-SOCKET
3	S-1640-15 HOUSING-PIN
2	S-1824-1 SWITCH
1	S-1360-10L CIRCUIT BREAKER

WIRE NO	GA	MATERIAL	LG	TERMINALS	SERIALS
LF 20	16		4	S-1635-2 S-1367-2-B	
LF 19	16		75	S-1635-2 S-1636-2	
LF 18	16			S-1493-2 S-1367-2-6	
LF 17	16		8	S-1493-2 S-1636-2	
LF 16	16			S-1636-2 S-1636-2	
LF 15	16		10	S-1493-2 S-1367-2-6	
LF 14	16		8	S-1493-2 S-1635-2	

EQUIPMENT TABLE	
CES-1000 IS APPLICABLE VENDOR CODES PER S-1400 CES-XXXX-CESNA SPEC. NO. S-XXX OR CMXXXX-CESNA STD. NO.	SUPERSEDES: P 11.10.1 SUPERSEDED BY:

WIRE TABLE		CONTRACT NO:		COMMERCIAL AIRCRAFT DIV. 8800 E. PAWNEE WICHITA, KANSAS	
DESIGN	COOK 6-16-72	NAME	DATE	Cessna AIRCRAFT CO.	
GROUP	N. Wall 6-22-72			TITLE	
DRAWN	COOK 6-16-72			WIRING DIAGRAM -	
CHECK	WHITE 6-9-72			LIGHT-FLASHING BEACON	
STRESS				(OPTIONAL)	
PROJ	S.R. Life 6-27-72	SIZE	CODE IDENT. NO.	DWG NO	
APPD		C	71379	0500062	
OTHER		SCALE: NONL			PAGE: 11.10.2

(SR7002)(SR7003)(SR7004)

Change 3 20-41

REVISION			
LET	DESCRIPTION	DATE	APPD
A	BY REV: ADD NOTE 3 ED & RR 00173 (SEE FRITZE - 0001 & ON) (SER 172156513 & ON)	RCA 8/26/67	RLC D&K 11/11

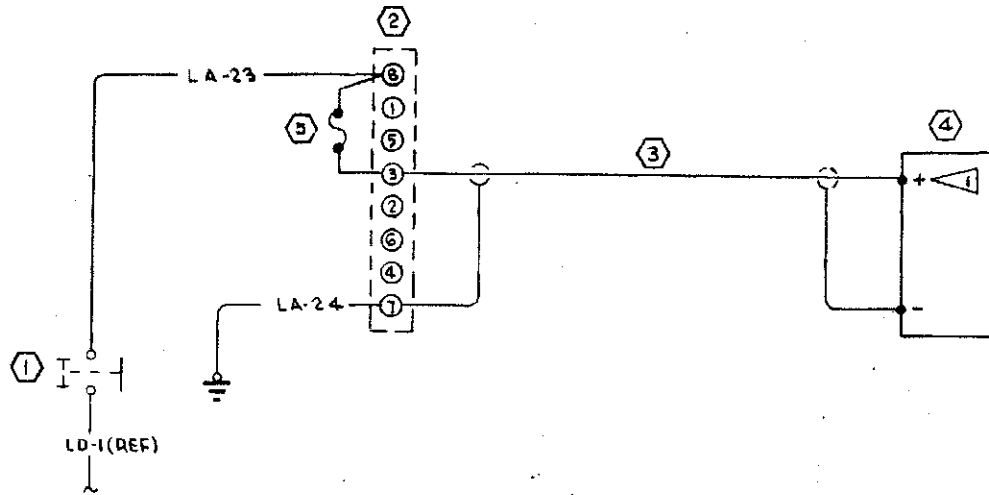

**INACTIVE:**  
 SER F172-0432 THRU SER F172-0435,  
 SER F172-0443,  
 SER F172-0447 THRU SER F17200754  
 SER 172156513 THRU SER 17259223 &  
 SER FR172E001 THRU SER FR17200225  
 ED & RR 10839  
 LD & P 3-26-70  
 JTW  
 RF

- NOTES:
- 1 CORRECT POLARITY MUST BE OBSERVED. OTHERWISE, PERMANENT DAMAGE TO COMPONENTS ON 1570142-2 WILL OCCUR.
  - 2 CENTER CONDUCTOR OF 8449 CABLE TO BE TERMINATED WITH 320733 (VENDOR 00779) AND AD JOINING SHIELD TO BE TERMINATED WITH 329636 (VENDOR 00779) TERMINATIONS TO BE MADE ON ONE END ONLY.
  - 3. APPLICABLE MODELS; 172, FR172E, & F172

WIRE CODE NO.	GA	MATERIAL	LG	TERMINALS	SERIALS
LA-24	20			2	SOLDER
LA-23	20			2	SOLDER

PART NO.	DESCRIPTION
5	1570141-1 FUSE ASSY
4	1570142-2 CIRCUIT BOARD ASSY
3	8499 CABLE (70903)
2	B-171 TERMINAL BLOCK (11785)
1	0713035 SWITCH

EQUIPMENT TABLE	
CES-1000 IS APPLICABLE VENDOR CODES PER S-1400 CES-XXXX*CESSNA SPEC. NO. S-XXX OR CMXXXX*CESSNA STD. NO.	SUPERSEDES: P 11.11.1

CONTRACT NO:			COMMERCIAL AIRCRAFT DIV. 5800 E. PAWNEE WICHITA, KANSAS		
DESIGN	NAME	DATE	Cessna AIRCRAFT CO. TITLE		
GROUP	W COOK	8-30-67	WIRING DIAGRAM -		
DRAWN	H. W. Shaw	8-31-67	MAP LIGHT, CONTROL		
CHECK	YAK SHAW	8-30-67	WHEEL		
STRESS		8-31-67	SIZE	CODE IDENT. NO.	DWG NO.
PROJECT	H. W. Shaw	8-31-67	C	71379	0500062
APPD	R. L. Murrell	8-31-67	SCALE: NONE	PAGE: 11.11	

(SER 172156513) ON



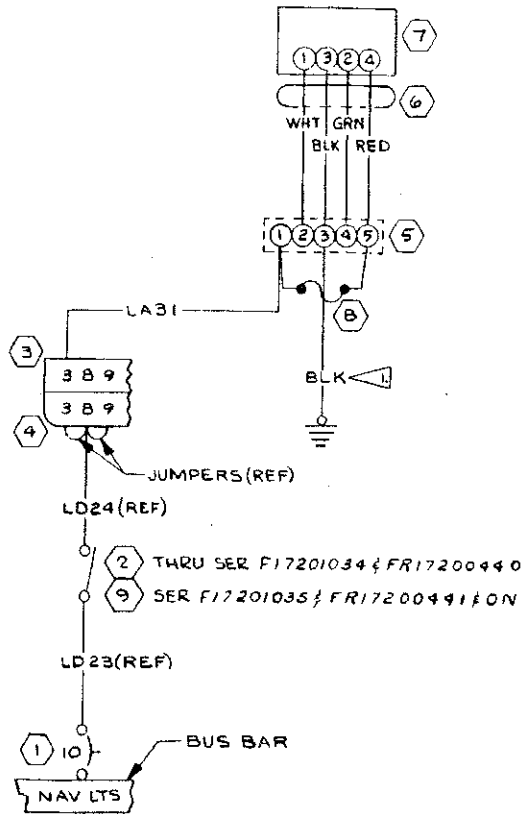

NOTES:

- 1. THIS WIRE NOT REQUIRED WHEN BOOM MIKE IS INSTALLED, REFER TO 0570400 PAGE 2.35 FOR REPLACEMENT WIRING WHEN BOOM MIKE IS INSTALLED
- 2. APPLICABLE MODELS: 172, F172 & FR172
- 3. VENDOR FOR 320733 & 329626 IS 00779

PART NO.	DESCRIPTION	QUANTITY
9	S-2160-1 SWITCH	
8	1570141-1 FUSE ASSY	
7	0570088-1 MAP LIGHT ASSY	
6	8409 CABLE (70903)	
5	351-11-05-001 TERMINAL STRIP (71789)	
4	S-1640-15 HOUSING-SOCKET	
3	S-1641-15 HOUSING-PIN	
2	S-1824-1 SWITCH	
1	S-1360-10 CIRCUIT BREAKER	

EQUIPMENT TABLE	
CES-1000 IS APPLICABLE VENDOR CODES PER S-1400 CES-XXXX-CESSNA SPEC. NO. S-XXX OR CMXXXX-CESSNA STD. NO.	SUPERSEDES: P 11.11 SUPERSEDED BY: 0570101 P 11.8.0

WIRE CODE NO	GA	MATERIAL	LG	TERMINALS	SERIALS
WHT	20	8409(70903)	3	320733 320733	3
BLK	20	8409(70903)	3	320733 320733	3
GRN	20	8409(70903)	3	320733 320733	3
RED	20	8409(70903)	3	320733 320733	3
BLK	20		3	S-1367-18 329626	3
LA31	20		15	329626 S-1636-1	3

CONTRACT NO:			WIRE TABLE		
DESIGN	NAME	DATE	Cessna, AIRCRAFT CO. COMMERCIAL AIRCRAFT DIV. 5800 E PAWNEE WICHITA, KANSAS		
GROUP			TITLE		
DRAWN			WIRING DIAGRAM -		
CHECK			MAP LIGHT, CONTROL WHEEL (OPTIONAL)		
STRESS			SIZE	CODE IDENT	DWG NO
PROJ			C	71379	0500062
APPD			SCALE	NONE	NONE
OTHER			NOTED		PAGE: 11.11.1

REVISION			
LET	DESCRIPTION	DATE	APPD
A	BY REV: 329626 WAS 320733/ LA31 & BLK; ADD 329626 TO NOTE 3 ED&RR 10985 (SR4352) II	ELY 11-11-70	WJW
B	BY REV: REVERSE TERMINALS 1 & 4 ON 0570088-1 ED&RR 10172 SER 17259224	ELY 8-17-70	WJW
C	BY REV: SER OUT S-1824-1 & SER IN S-2160-1 (SR 7303) (SR 7304) II	JOY 2-28-73	WJW
D	BY REV: ADD WIRE LENGTHS (NOW SHOP PRACTICE)	WLO 5-4-73	WJW

INACTIVE  
EFF THRU SER (SR 7303) II (SR 7304) II  
RAM  
JOY  
WJW

08-23-79  
02-23-79

Change 3 20-43

NOTES:

▲ ADD 5-1367-1-13 TERMINAL & 5-1493-2 TERMINAL, HRI FUSE & FUSEHOLDER (71400)

REVISION			
LET	DESCRIPTION	DATE	APPO
A	BY REV: C621001-0106 WAS C621001-0103	BLP 11173	

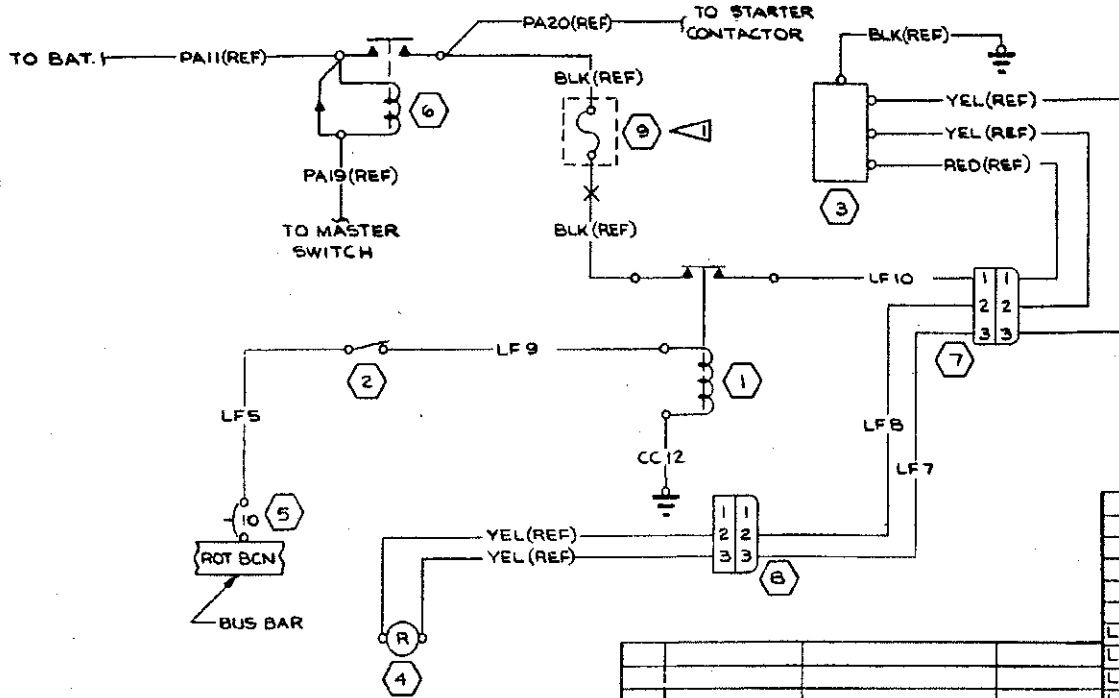

INACTIVE:  
EFF SER R172-0257  
THRU SER 17259224  
R/W 4-3-70  
R/W  
RF

PART NO.	DESCRIPTION	VENDOR
9	HRI FUSE & FUSEHOLDER (71400)	
8	5-1638-2 HOUSING-CAP	
7	5-1638-1 HOUSING-PLUG	
6	5-1579-1 BAT CONTACTOR	
5	5-1360-10 CIRCUIT BREAKER	
4	C621001-0106 LIGHT ASSY	
3	C594501-0201 FLASHER ASSY	
2	0713026-4 SWITCH ASSY	
1	0420017-2 RELAY	

EQUIPMENT TABLE	
CES-1000 IS APPLICABLE VENDOR CODES PER S1400 CES-XXXX-CESNA SPEC. NO. S-XXX OR CMXXXX-CESNA STD. NO.	SUPERSEDED BY: P 11.10.1

WIRE CODE NO.	CA	MATERIAL	LG	TERMINALS	SERIALS
LF 10	16			5-1636-2 5-1493-2	
LF 9	16			5-1637-2-B 5-1493-2	
LF 8	16			5-1636-2 5-1635-2	
LF 7	16			5-1636-2 5-1635-2	
LF 5	16			5-1367-2-2 5-1367-2-B	
CC 12	16			5-1493-2 5-1637-2-12	

CONTRACT NO.			Cessna AIRCRAFT CO.		COMMERCIAL AIRCRAFT DIV. 5800 E. PAWNEE WICHITA, KANSAS
DESIGN	NAME	DATE	TITLE		
			WIRING DIAGRAM - FLASHING BEACON		
GROUP	Blk. dir	11-14-67	SIZE	CODE IDENT. NO.	DWG NO.
DRAWN	HARRIS	11-13-67	C	71379	0500062
CHECK	M SWANEY	11-13-67	SCALE: NONE	T41-C	PAGE: 11.13
STRESS	A Sch. R	11-14-67	(SR5616) ED & RR 01321		
PROJECT	DL Koller	11-17-67			
APPO	P. F. Howe	12-14-67			

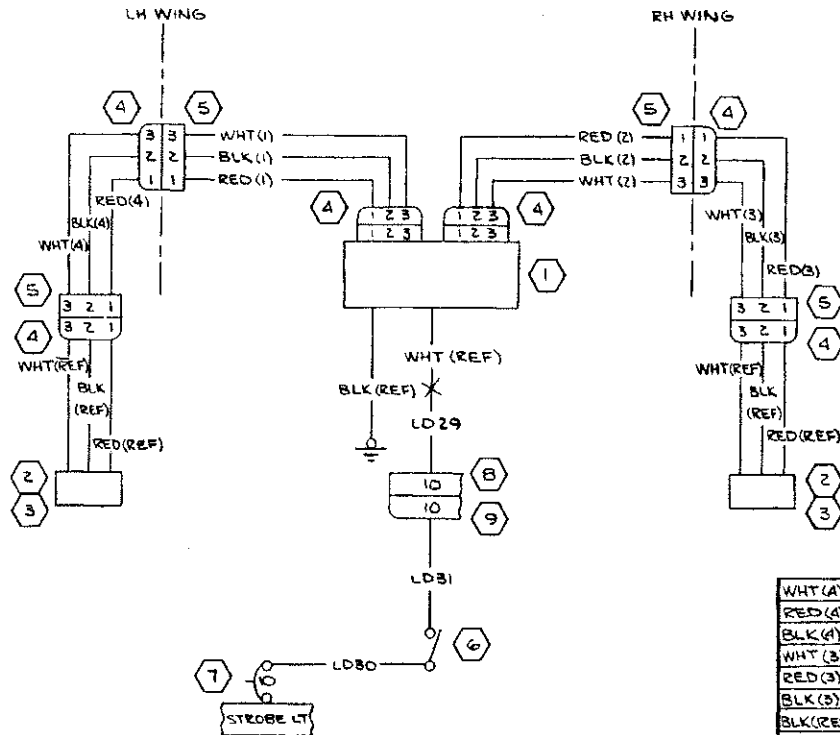

REVISION			
LET	DESCRIPTION	DATE	APPD
A	BY REV: 18 GA WAS 20 GA/LDS, LD30 & LD31 EDPR 10087	6-23-70	WJ RFP
B	BY REV: C622004-0103 WAS C622004-0101 (NOW SHOP PRACTICE)	8-20-70	WJ RFP

INACTIVE

EFFECTIVE SER 17259226, FIT001354, F17200226 THRU SER 17260758, F17200904 & F17200350  
WIC 6-16-72  
WJ RFP

**NOTES:**

- 1. THREE CONDUCTOR CABLE, BELDEN (10903) PART NO. 8710 OR EQUIVILANT TO BE USED
- 2. APPLICABLE MODELS: 172, F172 & F172Z

ITEM NO	PART NO.	DESCRIPTION
9	S-1640-1B	HOUSING-PIN
8	S-1641-5	HOUSING-SOCKET
7	S-1360-10	CIRCUIT BREAKER
6	S-1824-1	SWITCH
5	S-1638-1	HOUSING
4	S-1638-2	HOUSING
3	C622003-0104	LENS
2	C622003-0101	LIGHT UNIT
1	C622004-0103	POWER SUPPLY

EQUIPMENT TABLE	
CES-1000 IS APPLICABLE VENDOR CODES PER 51400 CES-XXXX-CESSNA SPEC. NO. S-XXX OR CMXXXX-CESSNA STD. NO.	SUPERSEDED BY: P 11.14.2

WHT(A)	1B		S-1635-2	S-1636-2	
RED(A)	1B		S-1635-2	S-1636-2	
BLK(A)	1B		S-1635-2	S-1636-2	
WHT(3)	1B		S-1635-2	S-1636-2	
RED(3)	1B		S-1635-2	S-1636-2	
BLK(3)	1B		S-1635-2	S-1636-2	
BLK(REF)			S-1367-1-B		
RED(2)	1B	1	S-1635-2	S-1636-2	
WHT(2)	1B				
BLK(2)	1B				
RED(1)	1B				
WHT(1)	1B				
BLK(1)	1B	1	S-1635-2	S-1636-2	
LD29	1B		S-1636-1	S-1370-1	
LD31	1B		S-1635-1	S-1493-1	
LD30	1B		S-1367-1-B	S-1493-1	
WIRE CODE NO	GA	MATERIAL	LG	TERMINALS	SERIALS

CONTRACT NO.				WIRE TABLE	
DESIGN	NAME	DATE	Cessna AIRCRAFT CO. COMMERCIAL AIRCRAFT DIV. 5800 E. PAWNEE WICHITA, KANSAS		
GROUP	RYOUNGERS	5-5-70	TITLE		
DRAWN	RYOUNGERS	5-5-70	WIRING DIAGRAM - WING TIP STROBE LIGHT		
CHECK	LK WHITE	5-6-70	SIZE		
STRESS			CODE IDENT. NO.		
PROJECT	RYOUNGERS	5-8-70	DWG. NO.		
APPD	RYOUNGERS	5-5-70	C 71379 0500062		
SCALE: NONE				PAGE: 11.14.1	

ED & RR 10009 (SR6352)(SR6353)(SR6354)K

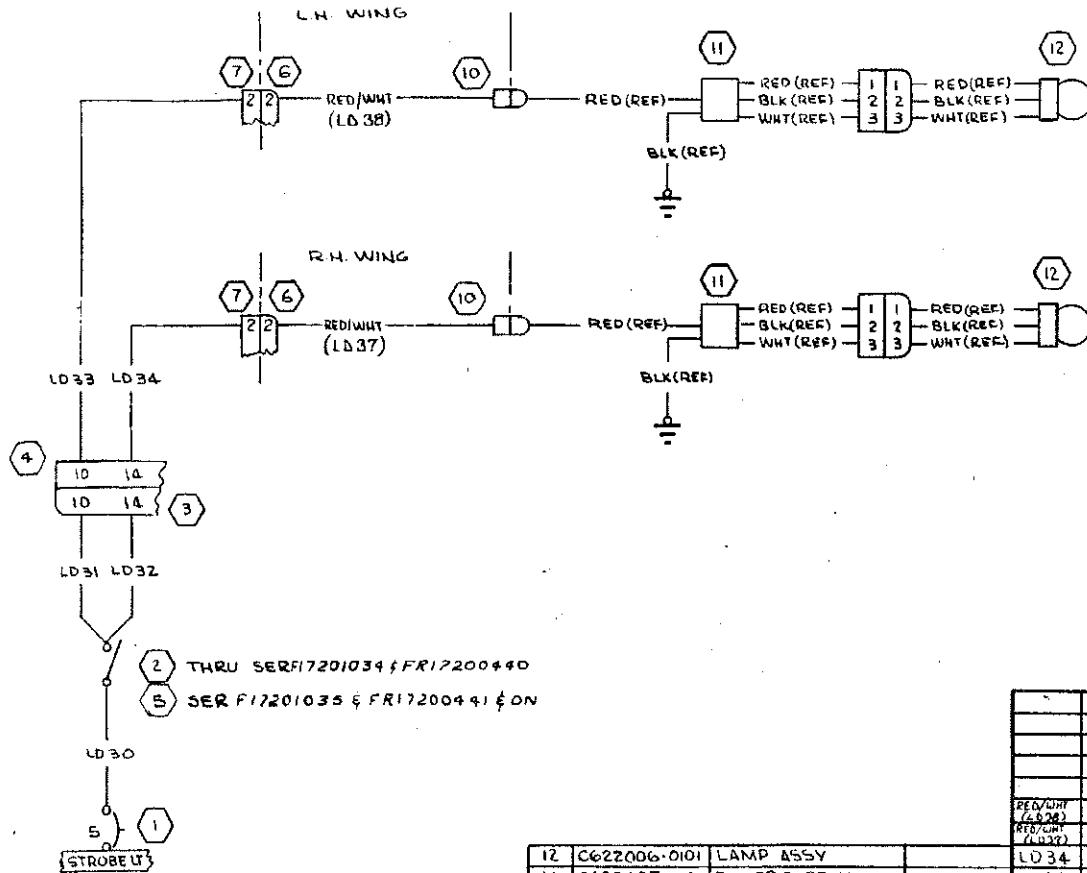

REVISION			
LET	DESCRIPTION	DATE	APPD
A	BY REV S-1637-1 & S-1637-2 AT LH (R.H. WING ROOST WAS S-1640-6 & S-1641-6 LH (S-1640-9 & S-1641-9 RH; S-1636-2/RED/WHT (1) & RED/WHT (2) WAS S-1635-2 NOW SHOP PRACTICE	DLP 5-27-72	REV NA
B	BY REV: SER OUT S-1824-1 SER IN S-2160-1 (SR7303) (SR7304)	SCY 2-18-73	REV NA
C	BY REV: ADD WIRE LENGTHS (NOW SHOP PRACTICE)	DLO 3-16-73	REV NA
D	BY REV: S-1640-9 & S-1641-9 WAS S-1637-1 & 2; RED/WHT (LD38) WAS RED/WHT (1) RED/WHT (LD37) WAS RED/WHT (2); S-1635-1 (LD38) (LD37) (LD32) (LD31) WAS S-1635-2, & S-1636-1 (LD38) (LD37) (LD32) (LD31) WAS S-1636-2; (172 EDD07) (NOW SHOP PRACTICE)	DEF 2-8-74	REV NA

INACTIVE  
 EFF THRU SER (SR7303) & (SR7304)  
 RAM  
 10-28-74

03-227-0505  
 03-227-0505

PART NO.	DESCRIPTION
12	C622006-0101 LAMP ASSY
11	C622007-0101 POWER SUPPLY
10	S-1637-2 HOUSING - PLUG
9	S-1637-1 HOUSING - CAP
8	S-1640-9 HOUSING - PIN
7	S-1641-9 HOUSING - SOCKET
6	S-1640-9 HOUSING - PIN
5	S-2160-1 SWITCH
4	S-1641-15 HOUSING - SOCKET
3	S-1640-15 HOUSING - PIN
2	S-1824-1 SWITCH
1	S-1360-5L CIRCUIT BREAKER

REF/WHT (LD38)	REF/WHT (LD37)	WIRE CODE NO	MATERIAL	LG	TERMINALS	SERIALS
18		-18-2-9	216	S-1636-1	S-1635-1 (STD)	
18		-18-2-9	216	S-1636-1	S-1635-1 (STD)	
LD34		18	74	S-1636-1	S-1636-1 (STD)	
LD33		18	81	S-1636-1	S-1636-1 (STD)	
LD32		18	8	SEE LD31	S-1635-1	
LD31		18	8	S-1636-2	S-1635-1	
LD30		18	10	S-1824-1	S-1493-1	

EQUIPMENT TABLE	
CES-1000 IS APPLICABLE VENDOR CODES PER S-1400 CES-XXXX-CESSNA SPEC. NO. S-XXX OR CMXXXX-CESSNA STD. NO.	SUPERSEDES: P 11.14.1 SUPERSEDED BY: 0570101 P 11.9.0

WIRE TABLE		
CONTRACT NO.	NAME	DATE
	COOK	6-16-72
DESIGN	GROUP	6-22-72
	W.W.	
DRAWN	CHECK	6-16-72
	WHITE	6-19-72
STRESS		
PROJ	APPD	6-27-72
	OTHER	
SIZE	CODE IDENT NO.	DWG NO
C	71379	0500062
SCALE: NONE	PAGE: 11 14.2	

Cessna AIRCRAFT CO.  
 COMMERCIAL AIRCRAFT DIV.  
 8800 E. PAWNEE WICHITA, KANSAS  
**WIRING DIAGRAM - WING TIP STROBE LIGHT (OPTIONAL)**

(SR1002) (SR1003) (SR1004)  
 (1/25/74) (F17200805) (F17200441)













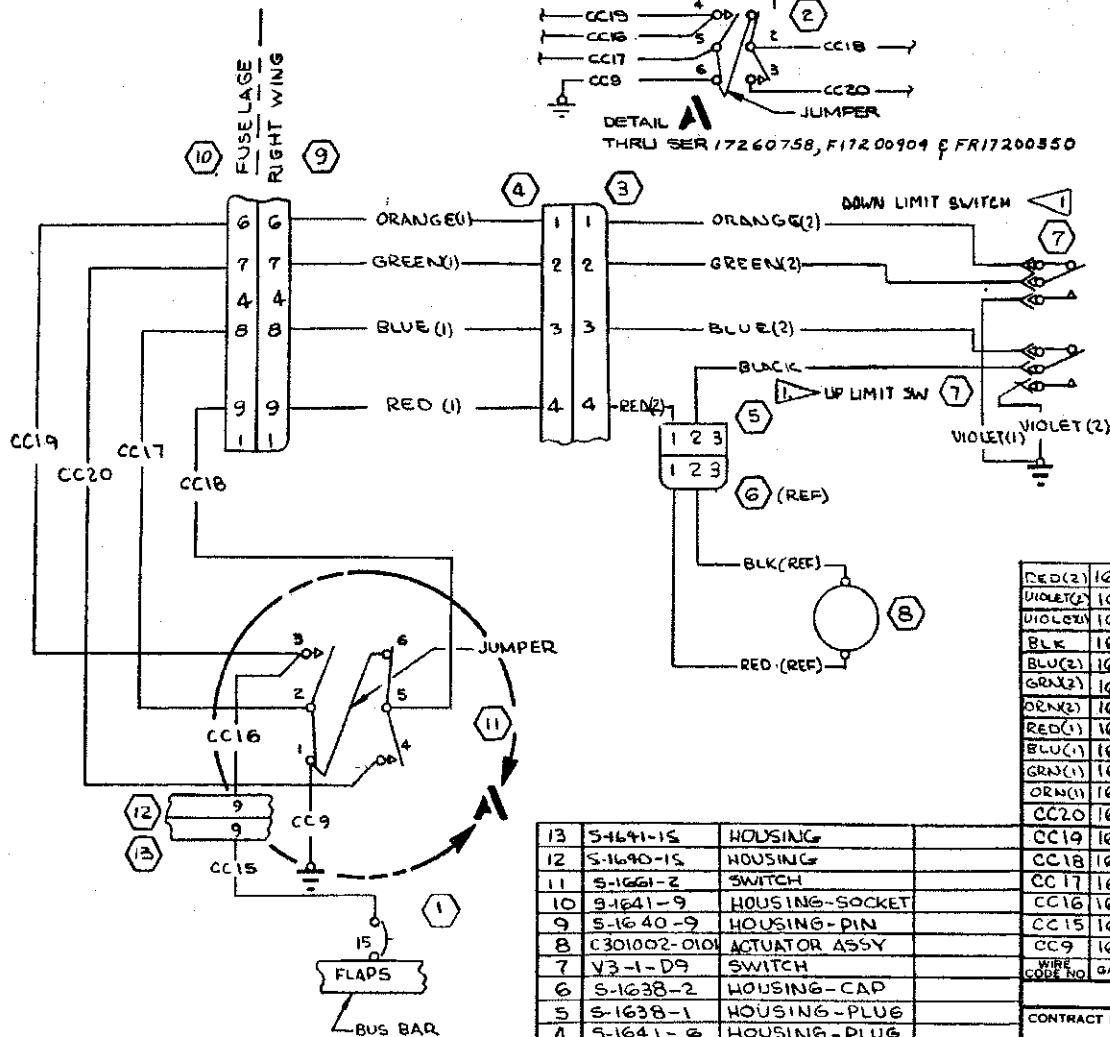

REVISION			
LET	DESCRIPTION	DATE	APPD
A	BY REV: DELETED WIRES CC 21 THRU CC 27 (NEVER USED) REPLACED WITH COLOR CODED WIRES ITEM 7 3 & 4 WERE 5 & 6. ITEMS 9 & 10 WERE 3 & 4 (NOW SHOP PRACTICE)	7-1-71 WRC	N/W RAM RF
B	BY REV: ADD DETAIL A, S-1661-2 & SER; SER OUT S-1661-1 SET002 (REF S-1600) (REF (SET004) (REF)	DLP 10-5-72	N/W RAM RF
C	BY REV: ADD WIRE LENGTHS (NOW SHOP PRACTICE)	JLO 5-16-73	N/W RF
D	BY REV: CHANGE LG, VIOLET (1) (2) 19 WAS 6, ORN(2) 13 WAS 12 RED (1) (2) 19 WAS 75 WAS 90, S-1636-2 (CC 17, 18, 19 & 20) WAS S-1635-2 (172 ED007) (NOW SHOP PRACTICE)	JEF 2/8/74	N/W RF
E	BY REV: S-1640-15 WAS S-1641-9 & S-1641-15 WAS S-1640-9 (NOW SHOP PRACTICE)	JLO 7-10-74	N/W RF

INACTIVE  
EFF THRU SER  
RAM  
JCY  
10-25-74  
P15 RF

WIRE CODE NO	GA	MATERIAL	LG	TERMINALS	SERIALS
RED(2)	16		13	S-1636-2	S-1635-2
VIOLET(2)	16		19	S-1493-2	S-1367-2-B
VIOLET(1)	16		19	S-1493-2	S-1367-2-B
BLK	18		13	S-1636-2	S-1493-2
BLU(2)	16		13	S-1635-2	
GRN(2)	16		13	S-1635-2	
ORN(2)	16		13	S-1635-2	S-1493-2
RED(1)	16		75	S-1635-2	S-1636-2
BLU(1)	16		75		
GRN(1)	16		75		
ORN(1)	16		75	S-1635-2	S-1636-2
CC20	16		68	S-167-2-6	S-1636-2
CC19	16		68		
CC18	16		68		
CC17	16		68	S-170-2-6	S-1636-2
CC16	16		16	S-1636-2	S-1637-2-6
CC15	16		15	S-1635-2	S-1677-2-6
CC9	16		6	S-1637-2-6	S-1637-2-8

ITEM NO	PART NO.	DESCRIPTION
13	S-1641-15	HOUSING
12	S-1640-15	HOUSING
11	S-1661-2	SWITCH
10	S-1641-9	HOUSING-SOCKET
9	S-1640-9	HOUSING-PIN
8	C301002-0101	ACTUATOR ASSY
7	V3-1-D9	SWITCH
6	S-1638-2	HOUSING-CAP
5	S-1638-1	HOUSING-PLUG
4	S-1641-6	HOUSING-PLUG
3	S-1640-6	HOUSING-PIN
2	S-1661-1	SWITCH
1	S-1360-15	CIRCUIT BKR

EQUIPMENT TABLE	
ITEM NO	DESCRIPTION
13	S-1641-15 HOUSING
12	S-1640-15 HOUSING
11	S-1661-2 SWITCH
10	S-1641-9 HOUSING-SOCKET
9	S-1640-9 HOUSING-PIN
8	C301002-0101 ACTUATOR ASSY
7	V3-1-D9 SWITCH
6	S-1638-2 HOUSING-CAP
5	S-1638-1 HOUSING-PLUG
4	S-1641-6 HOUSING-PLUG
3	S-1640-6 HOUSING-PIN
2	S-1661-1 SWITCH
1	S-1360-15 CIRCUIT BKR

CONTRACT NO:			WIRE TABLE	
DESIGN	NAME	DATE	SIZE	CODE IDENT. NO
			C	71379
DESIGN	COOK	12-11-70	DWG NO	0500062
GROUP	N. WILCOX	2-2-71	SCALE	NONE
DRAWN	COOK	12-11-70		
CHECK	LK WHITE	2-2-71		
STRESS				
PROJ	2-12-71			
APPD				
OTHER				

NOTES:  
1 THESE SWITCHES PART OF C301002-0101 ACTUATOR ASSY.

CES-1000 IS APPLICABLE  
VENDOR CODES PER S-1400  
CES-XXXX-CESSNA SPEC. NO.  
S-XXX OR CMXXXX-CESSNA  
STD. NO.

SUPERSEDES: 14.7.1  
SUPERSEDED BY: P14.1.0 P14.1.1

COMMERCIAL AIRCRAFT DIV.  
5800 E. PAWNEE  
WICHITA, KANSAS  
TITLE: WIRING DIAGRAM - WING FLAPS-ELECTRIC  
SCALE: NONE 117-F11L-FR11L PAGE: 14.7.2

(SRG584)  
(1717200298)

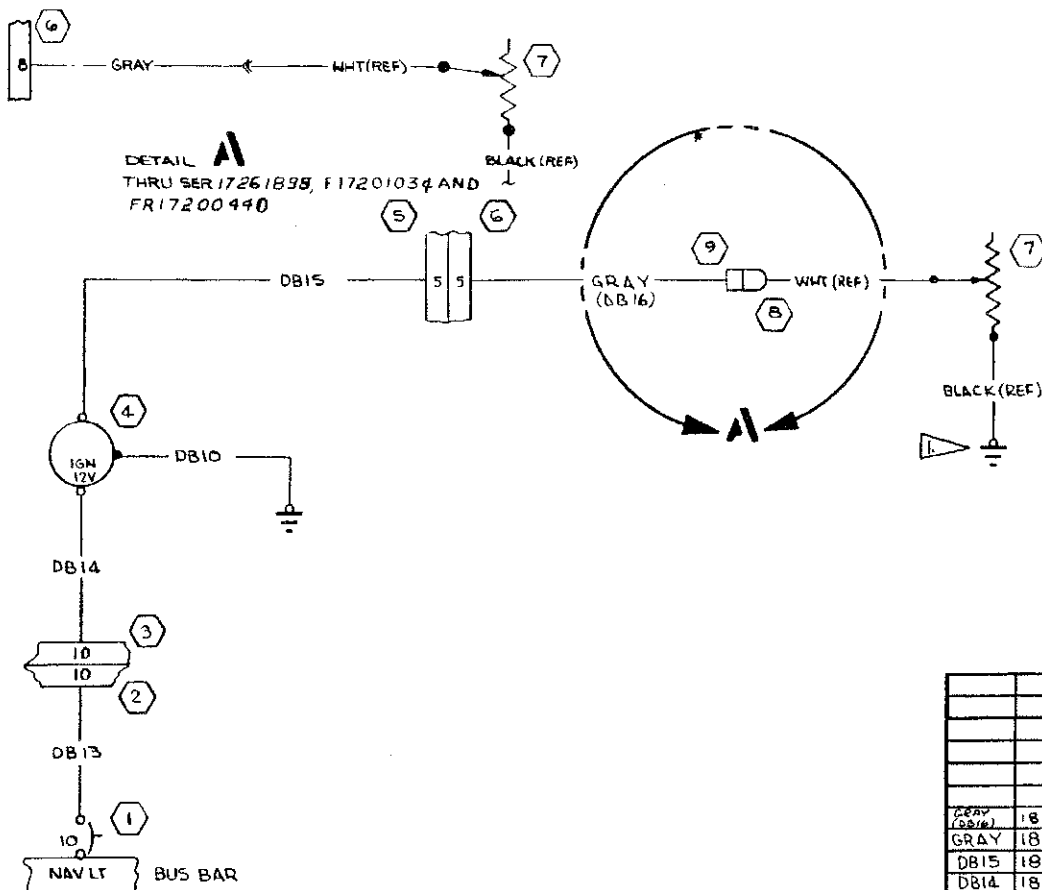

REVISION			
LET	DESCRIPTION	DATE	APPD
A	BY REV: PIN 8 WAS PIN 9; ITEMS 5 & 6 WERE S-1640-9 & S-1631-G. (NOW SHOP PRACTICE)	7-1-71 WRC	N/W/IK DKM RF
B	BY REV: S-1367-1-G WAS SOLDER & S-1367-1-10 WAS S-1367-1-8 PER DB10, ADD WIRE LENGTHS, ADD DETAIL 'A', SER OUT GRAY, SER IN GRAY (1), ADD ITEM DB19. NOW SHOP PRACTICE (SR7303)(SR7304)	3-0 5-21-73	N/W A-1-1 RF
C	BY REV: GRAY(DB16) WAS GRAY (1); PINS 5 WAS PIN 8; S-1635-1 GRAY (DB16) WAS S-1636-1 (DB16), S-1636-1 (DB15) WAS S-1635-1 (DB15) (172 E0007) (NOW SHOP PRACTICE)	DEF 2/8/74	JCY N/W RF

INACTIVE:  
 EFF THRU SER (SR7303) (SR7304)  
 (SR7305) (SR7306)  
 (SR7307) (SR7308)  
 (SR7309) (SR7310)  
 (SR7311) (SR7312)  
 (SR7313) (SR7314)

SER 17261833  
 10-23-74

ITEM NO	PART NO.	DESCRIPTION
9	S-1637-2	HOUSING
8	S-1637-1	HOUSING
7	C990501-0101	FLAP POSITION XMTR
6	S-1640-9	HOUSING-SOCKET
5	S-1641-9	HOUSING-PIN
4	C668001-0103	FLAP POSITION IND
3	S-1640-15	HOUSING-PIN
2	S-1641-15	HOUSING-SOCKET
1	S-1660-10	CIRCUIT BREAKER

EQUIPMENT TABLE	
ITEM NO	DESCRIPTION
	CES-1000 IS APPLICABLE VENDOR CODES PER S-14DD CES-XXXX*CESSNA SPEC. NO. S-XXX OR CMXXXX*CESSNA STD. NO.
	SUPERSEDES: Pg 14.7.1
	SUPERSEDED BY: 0570101 P 14.2.0

WIRE CODE NO	GA	MATERIAL	LG	TERMINALS	SERIALS
GRAY (DB16)	18	-18-B	100	S-1635-1	S-1636-1
GRAY	18	-18-B	100	S-1635-1	S-1636-1
DB15	18		62	S-1367-1-10	S-1636-1
DB14	18		19	S-1635-1	S-1367-1-10
DB13	18		15	S-1367-1-6	S-1636-1
DB10	18		5	S-1367-1-6	S-1367-1-10

CONTRACT NO.		NAME		DATE	COMMERCIAL AIRCRAFT DIV. 5800 E. PAWNEE WICHITA, KANSAS	
DESIGN	COOK	2-1-71			<b>Cessna. AIRCRAFT CO.</b> TITLE <b>WIRING DIAGRAM —            FLAP POSITION INDICATOR</b>	
GROUP	N. Will	2-2-71				
DRAWN	COOK	2-1-71				
CHECK	L.V. WHITE	2-2-71				
STRESS						
PROJ				2-17-71	SIZE	CODE IDENT. NO.
APPD					C	71379
OTHER					DWG NO	0500062
					SCALE	NONE
						171- F172- F171Z
						PAGE 14.7.3

NOTES:  
 1. GROUND BLACK WIRE ON TRANSMITTER MOUNTING BOLT.

Change 3 20-53/(20-54 blank)

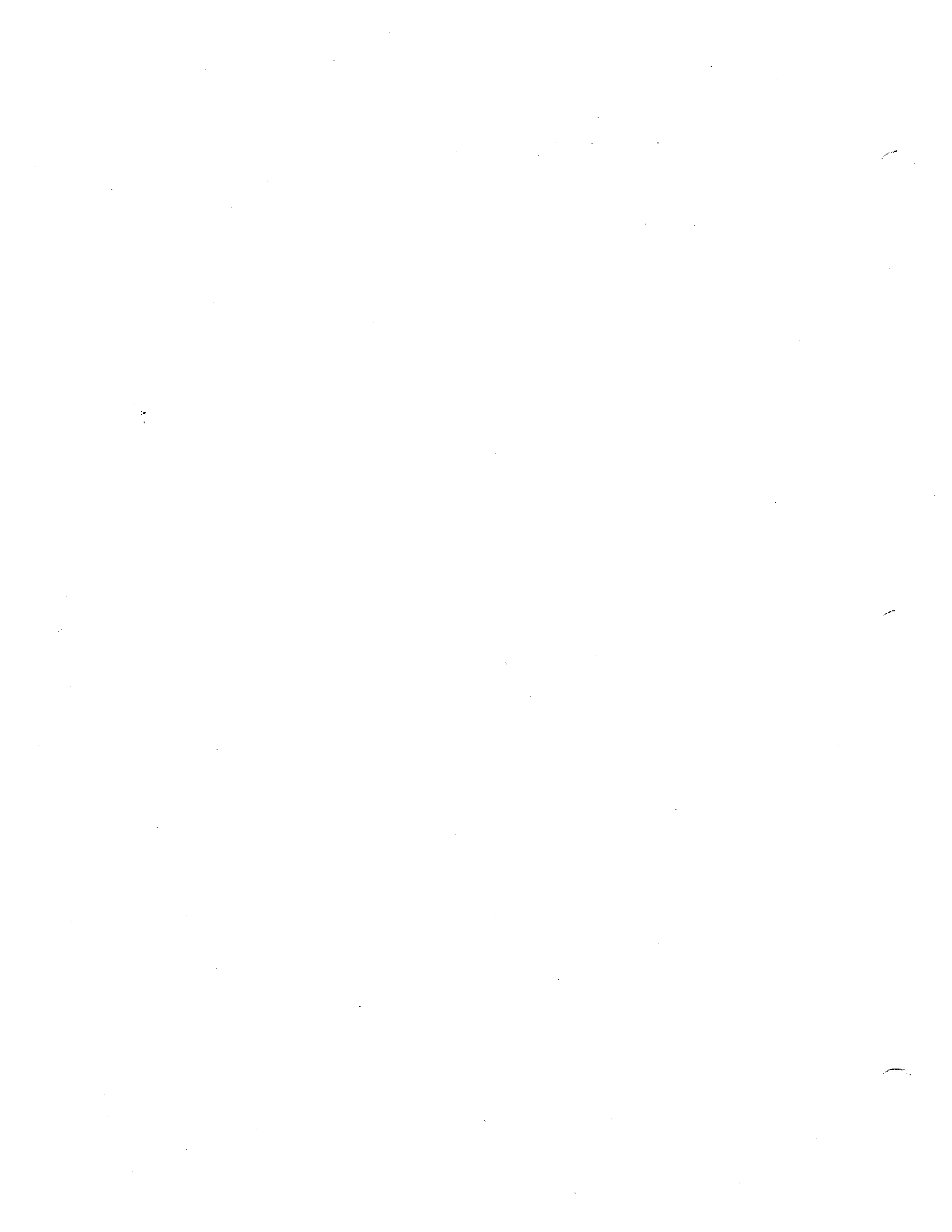













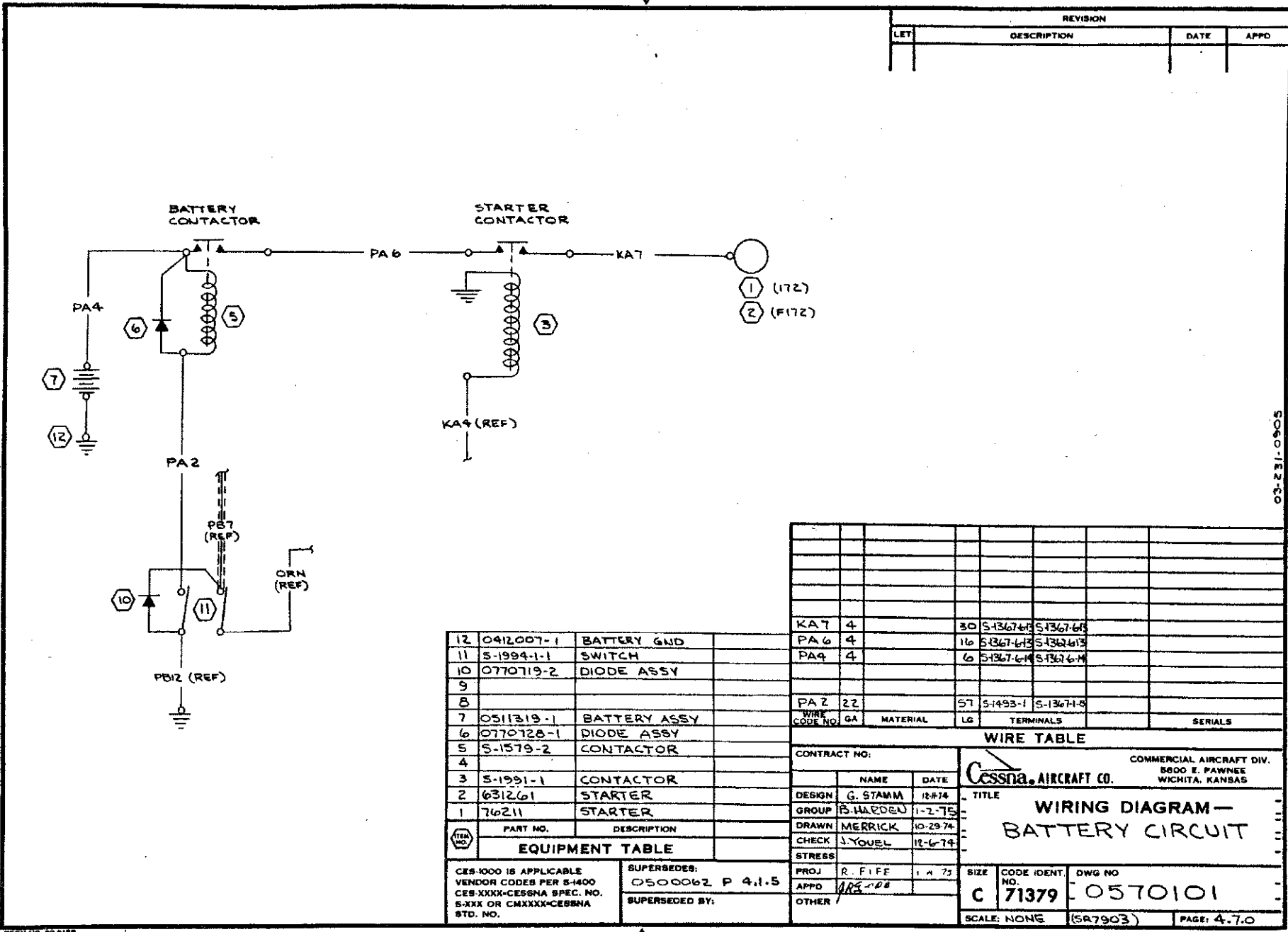

REVISION			
LET	DESCRIPTION	DATE	APPO

PART NO.	DESCRIPTION
12	0412007-1 BATTERY GND
11	5-1994-1-1 SWITCH
10	0770719-2 DIODE ASSY
9	
8	
7	0511319-1 BATTERY ASSY
6	0770726-1 DIODE ASSY
5	S-1579-2 CONTACTOR
4	
3	5-1991-1 CONTACTOR
2	631261 STARTER
1	76211 STARTER

WIRE NO.	GA	MATERIAL	LG	TERMINALS	SERIALS
KA7	4	30	5-1367-6-1	5-1367-6-1	
PA6	4	116	5-1367-6-1	5-1367-6-1	
PA4	4	6	5-1367-6-1	5-1367-6-1	
PA2	22	57	5-1493-1	5-1367-1-8	

CEB-1000 IS APPLICABLE  
 VENDOR CODES PER 5-1400  
 CEB-XXXX-CESSNA SPEC. NO.  
 5-XXX OR CNXXXX-CESSNA  
 STD. NO.

SUPERSEDES:  
 0500062 P 4.1.5  
 SUPERSEDED BY:

CONTRACT NO:	NAME	DATE
DESIGN	G. STAMM	12-74
GROUP	B. HARRDEN	1-2-75
DRAWN	MERRICK	10-29-74
CHECK	J. YOUNG	12-6-74
STRESS:		
PROJ	R. FIFE	1-4-75
APPO	APP-108	
OTHER		

WIRE TABLE		
COMMERCIAL AIRCRAFT DIV. 5800 E. PAWNEE WICHITA, KANSAS		Cessna AIRCRAFT CO.
TITLE <b>WIRING DIAGRAM - BATTERY CIRCUIT</b>		
SIZE	CODE IDENT. NO.	DWG NO.
C	71379	0570101
SCALE: NONE	(SR7903)	PAGE: 4-7.0

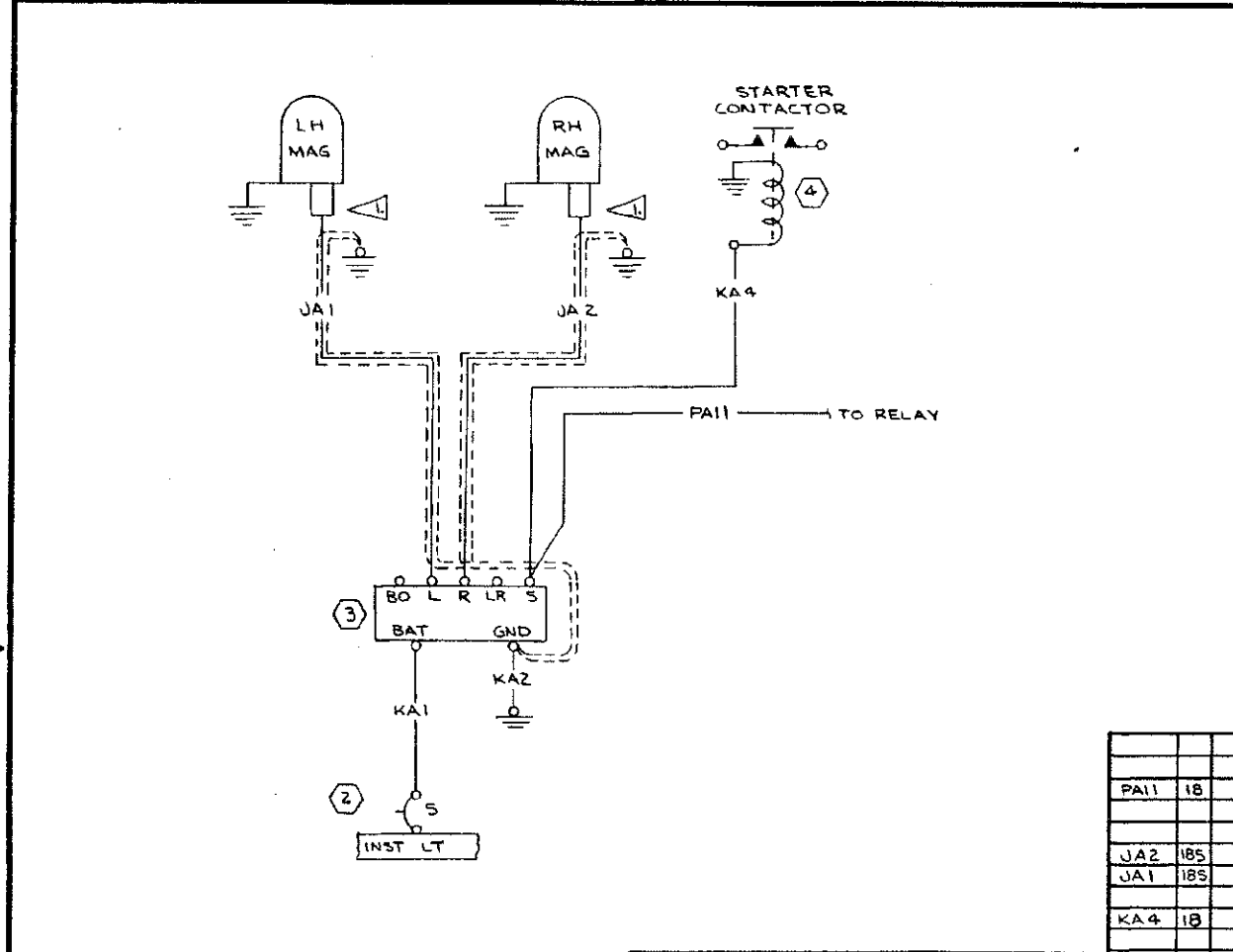

REVISION			
LET	DESCRIPTION	DATE	APPD

5050-152-10  
5050-152-10

NOTES:  
 1. ADD S-1488-1 NIPPLES TO MAG END OF WIRES

PART NO.	DESCRIPTION
4	S-1991-1 CONTACTOR
3	C292501-0105 IGNITION SWITCH
2	S-1360-5L CIRCUIT BREAKER

**EQUIPMENT TABLE**

CES-1000 IS APPLICABLE  
 VENDOR CODES PER S-1400  
 CES-XXXX-CESSNA SPEC. NO.  
 S-XXX OR CMXXXX-CESSNA  
 STD. NO.

SUPERSEDES:  
 0500062 P 5.1.1

SUPERSEDED BY:

WIRE CODE NO	GA	MATERIAL	LG	TERMINALS	SERIALS
PA11	18	B	5-1367-1-6	S-1493-1	
JA2	18S	50	S-1367-1-6	S-1367-1-6	
JA1	18S	45	S-1367-1-4	S-1367-1-4	
KA 4	18	52	S-1367-4-4	S-1367-4-0	
KA2	18	B	S-1367-1-6	S-1367-1-8	
KA1	22	16	S-1367-6-6	S-1367-4-6	

**WIRE TABLE**

CONTRACT NO: \_\_\_\_\_

DESIGN	G STAMM	DATE	12/74
GROUP	B HADSON	DATE	1-2-75
DRAWN	MERRICK	DATE	10-31-74
CHECK	J. YOUNG	DATE	12-6-74
STRESS			

**Cessna AIRCRAFT CO.**  
 COMMERCIAL AIRCRAFT DIV.  
 5800 E. PAWNEE  
 WICHITA, KANSAS

**TITLE**  
 WIRING DIAGRAM --  
 MAGNETO SYSTEM

PROJ	RIFE	DATE	1.1.75
APPD	APB		
OTHER			

SIZE: C CODE IDENT NO: 71379 DWG NO: 0570101  
 SCALE: NONE (SR7903)(SR7904) PAGE: 5.1.0

Change 3 20-61

REVISION			
LET	DESCRIPTION	DATE	APPD
A	BY REV: C669512-0102 WAS C669511-0102; (SR7904)	BLA 1-22-75	<i>[Signature]</i> RF
B	BY REV: DELETE EE2 (SR1903)(REF)(SR7904)(REF)	RJP 4-6-75	<i>[Signature]</i> RF

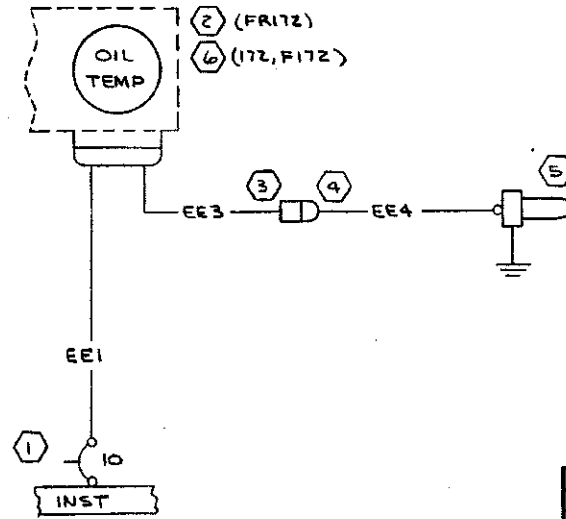

5050-157-50  
5050-157-40

WIRE CODE NO	GA	MATERIAL	LC	TERMINALS	SERIALS
EE4	ZO	S-1635-1		S-1367-110	
EE3	ZO	SOLDER		S-1636-1	
EE1	ZO	SOLDER		S-1367-1B	

ITEM NO	PART NO.	DESCRIPTION
6	C669512-0101	INST CLUSTER
5	S-1630-1	SENDING UNIT
4	S-1637-1	HOUSING
3	S-1637-2	HOUSING
2	C669512-0102	INST CLUSTER
1	S-1360-10L	CIRCUIT BREAKER

CEB-1000 IS APPLICABLE  
VENDOR CODES PER S-1400  
CES-XXXX-CESSNA SPEC. NO.  
B-XXX OR CMXXXX-CESSNA  
STD. NO.

SUPERSEDES:  
SUPERSEDED BY:

CONTRACT NO:			Cessna AIRCRAFT CO.		COMMERCIAL AIRCRAFT DIV. 8900 E. PAWNEE WICHITA, KANSAS
DESIGN	NAME	DATE	SIZE	CODE IDENT. NO.	DWG NO
	G SHMM	1-2-75	C	71379	0570101
GROUP	S. HARDEN	1-2-75	SCALE: NONE (50798)(SR7904) PAGE: 7, 2, 0		
DRAWN	MERRICK	10-31-74			
CHECK	J. YOUNG	12-6-74			
STRESS					
PROJ	R. FIFE	1-4-75			
APPD	<i>[Signature]</i>				
OTHER					

WIRING DIAGRAM -  
OIL TEMPERATURE

REVISION			
LET	DESCRIPTION	DATE	APPD

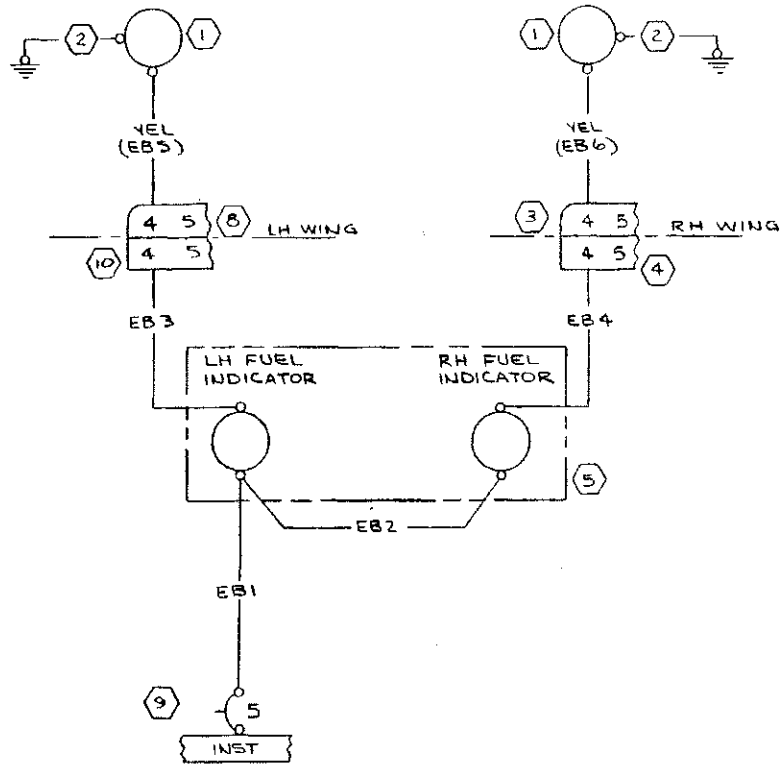

5060-152-50  
5060-152-60

10	S-1641-6	HOUSING
9	S-1360-5L	CIRCUIT BREAKER
8	S-1640-1	HOUSING

ITEM NO	PART NO.	DESCRIPTION
5	C669511-0102	INST CLUSTER
4	S-1641-6	HOUSING
3	S-1640-6	HOUSING
2	0413247	STRAP-GND
1	0523557-1	XMTR-FUEL GAGE

CES-1000 IS APPLICABLE  
VENDOR CODES PER S-1400  
CES-XXXX\*CESSNA SPEC. NO.  
S-XXX OR CMXXXX\*CESSNA  
STD. NO.

SUPERSEDES: P 8.1.2  
0300062 P 8.1.3  
SUPERSEDED BY:

WIRE CODE NO	GA	MATERIAL	LG	TERMINALS	SERIALS
YEL EB6	22	-18-4	58	S-1635-1 S-1367-1-10	
YEL EB5	↑	-18-4	38	S-1635-1 S-1367-1-10	
EB4			82	S-1367-1-10 S-1636-1	
EB3			45	S-1367-1-10 S-1636-1	
EB2	↑		3	S-1367-1-10 S-1367-1-10	
EB1	22		16	S-1367-1-6 S-1367-1-10	

WIRE TABLE			CONTRACT NO:		COMMERCIAL AIRCRAFT DIV. 5800 E. PAWNEE WICHITA, KANSAS			
DESIGN	G. STAMM	12-74	 <b>WIRING DIAGRAM —</b> <b>FUEL GAGE &amp; TRANSMITTER</b>					
GROUP	B. HARDEU	2-75						
DRAWN	MERRICK	10-31-74						
CHECK	J. TOWEL	12-16-74						
STRESS			PROJ	1111	1-1-75	SIZE	CODE IDENT	DWG NO
APPD	J. TOWEL		APPD			C	71379	0570101
OTHER			SCALE	NONE		(SR7503)	(SR7504)	PAGE: 8.1.0

Change 3 20-63



REVISION			
LET	DESCRIPTION	DATE	APPD

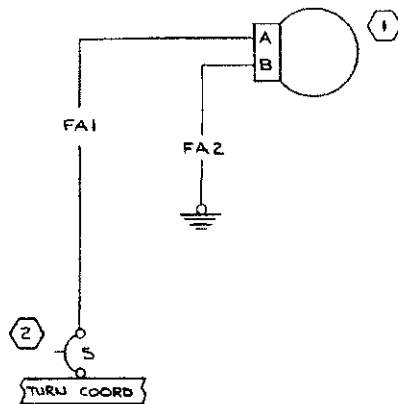

5060-132-30  
03-22-50  
09-11-0905

WIRE CODE NO.	GA	MATERIAL	LG	TERMINALS	SERIALS
FA2	18		12	5-1367-1-8	SOLDER
FA1	22		10	5-4367-1-2	SOLDER

**WIRE TABLE**

PART NO.	DESCRIPTION
2	5-1360 -5L CIRCUIT BREAKER
1	C661003-0501 TURN COORDINATOR

**EQUIPMENT TABLE**

CES-1000 IS APPLICABLE  
VENDOR CODES PER 6-1400  
CES-XXXX-CESSNA SPEC. NO.  
S-XXX OR CMXXXX-CESSNA  
STD. NO.

SUPERSEDES:  
0500062 P 9.3

SUPERSEDED BY:

CONTRACT NO.		Cessna AIRCRAFT CO. COMMERCIAL AIRCRAFT DIV. 5800 E. PAWNEE WICHITA, KANSAS	
DESIGN	NAME	DATE	TITLE
GROUP	G. STAMM	11-2-74	WIRING DIAGRAM -
DRAWN	D. HARDEN	1-2-75	TURN COORDINATOR
CHECK	MERRICK	10-9-74	
STRESS	J. TOLLEW	12-6-74	
PROJ	R. FILL	1-5-75	SIZE
APPD	PPS-LDB		CODE IDENT NO.
OTHER			DWG NO.
			C 71379 - 0570101
			SCALE: NONE
			(SR1903) (SR1904) PAGE: 9.1.0

Change 3 20-65

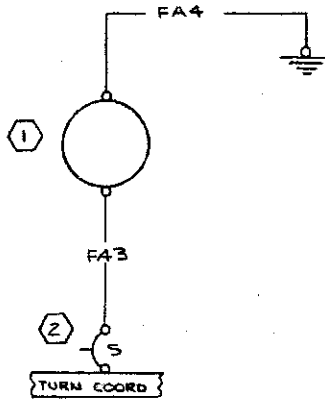

REVISION			
LET	DESCRIPTION	DATE	APPD

5060-152-10  
5060-152-10

WIRE NO	GA	MATERIAL	LG	TERMINALS	SERIALS
FA4	18		12	5-13671-8	5-13671-8
FA3	22		10	5-13671-6	5-13671-8

ITEM NO.	PART NO.	DESCRIPTION
2	S-1360-5L	CIRCUIT BREAKER
1	S-1413-2	TURN & BANK IND

CONTRACT NO:			COMMERCIAL AIRCRAFT DIV. 8800 E. PAWNEE WICHITA, KANSAS		
DESIGN	G STAMM	12-74	Cessna AIRCRAFT CO.		
GROUP	B HARDEA	1-2-75	TITLE		
DRAWN	MERRICK	10-2-74	WIRING DIAGRAM -		
CHECK	J YOWEL	12-6-74	TURN & BANK INDICATOR		
STRESS			(OPT)		
PROJ	R FIFE	1-5-75	SIZE	CODE IDENT.	DWG NO
APPD	JRS/JEM		C	71379	0570101
OTHER			SCALE: NONE	SR17003 (SR17004)	PAGE: 3.2.0

CES-1000 IS APPLICABLE  
VENDOR CODES PER S-1400  
CES-XXXX-CESNA SPEC. NO.  
S-XXX OR CMXXXX-CESNA  
STD. NO.

SUPERSEDED:  
0500062 P 9.4  
SUPERSEDED BY:





REVISION			
LET	DESCRIPTION	DATE	APPD

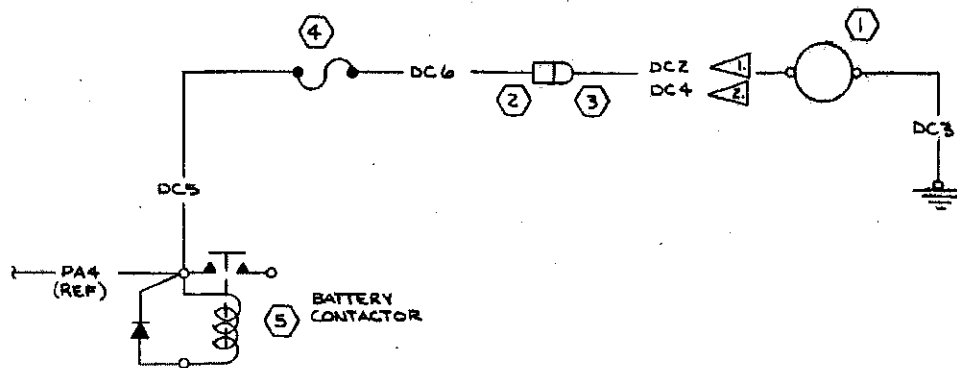

50605-132-00  
04-231-090

NOTES :

- ▽ APPLIES TO FR17Z ONLY
- ▽ APPLIES TO 17Z & FITZ ONLY

PART NO.	DESCRIPTION
5	S-1579-2 CONTACTOR
4	S-1091-1 FUSE
3	S-1637-1 HOUSING
2	S-1637-2 HOUSING
1	S-1317N2 CLOCK

**EQUIPMENT TABLE**

CES-1000 IS APPLICABLE VENDOR CODES PER S-1400 CES-XXXX-CESSNA SPEC. NO. S-XXX OR CMXXX-CESSNA STD. NO.	SUPERSEDES: 0500062 P 10.2
	SUPERSEDED BY:

REF	QTY	DESCRIPTION	TERMINALS	SERIALS
DC 6	22	-22-2	SOLOER	S-1630-1
DC 5	22	-22-4	10	S-1367-10 SOLDER
DC 2	22	-22-2	76	S-1635-1 S-1367-10
DC 3	22		18	S-1367-18 S-1367-16
RES	22	-22-2	150	S-1635-1 S-1367-10

**WIRE TABLE**

WIRE CODE NO.	GA	MATERIAL	LG	TERMINALS	SERIALS

CONTRACT NO:  

DESIGN	NAME	DATE
G. STAMM		1-1-74
D. HAZDEN		1-2-75
MERRICK		6-3-74
J. YOWEL		12-6-74

COMMERCIAL AIRCRAFT DIV.  
5800 E. PAWNEE  
WICHITA, KANSAS

**Cessna AIRCRAFT CO.**

TITLE: **WIRING DIAGRAM - CLOCK (OPT)**

PROJ	APPD	OTHER	SIZE	CODE IDENT. NO.	OWG NO.
R. FIFE			C	71379	0570101

SCALE: NONE (S-1503) (S-1504) PAGE: 10.1.0

REVISION			
LET	DESCRIPTION	DATE	APPD

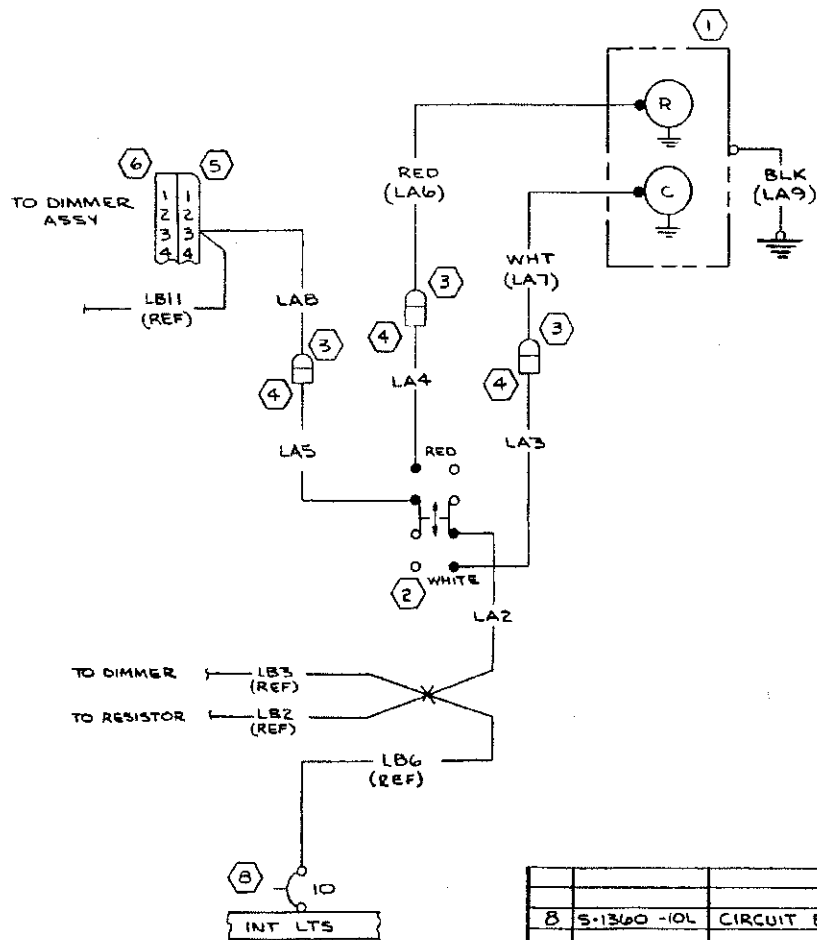

ITEM NO	GA	MATERIAL	LG	TERMINALS	SERIALS
BLK (LA2)	18	-18-0	12	S-1367-10	S43671-8
LAB	24	SEE LB11	24	S-1635-1	
WHT (LA7)	10	-18-9	10	S-1635-2	SOLDER
RED (LA6)	10	-18-2	10	S-1635-2	SOLDER
LA5	8		8	SOLDER	S-1636-1
LA4	6		6	SOLDER	S-1636-1
LA3	7		7	SOLDER	S-1636-1
LA2	18		7	SOLDER	SEE LB6

ITEM NO	PART NO.	DESCRIPTION
8	S-1360-10L	CIRCUIT BREAKER
6	S-1640-6	HOUSING
5	S-1641-6	HOUSING
4	S-1631-2	HOUSING
3	S-1631-1	HOUSING
2	S-1501-1	SWITCH
1	1470089-14	LIGHT ASSY

ITEM NO	PART NO.	DESCRIPTION

**WIRE TABLE**

CONTRACT NO: \_\_\_\_\_

DESIGN: G. STAMM    DATE: 12-74

GROUP: B. HADDEN    1-2-75

DRAWN: MERRICK    10-3-74

CHECK: J. YOUNG    12-6-74

STRESS: \_\_\_\_\_

PROJ: 21174    4 73

APPD: JRS    228

OTHER: \_\_\_\_\_

**Cessna AIRCRAFT CO.**    COMMERCIAL AIRCRAFT DIV.  
5800 E. PAWNEE    WICHITA, KANSAS

TITLE: **WIRING DIAGRAM - MAP & AUXILIARY INSTRUMENT LIGHT (OPT)**

SIZE: C    CODE IDENT NO: 71379    DWG NO: 0570101

SCALE: NONE    (SR1903) (247504)    PAGE: 11.1.0

Change 3    20-69

5060-152-3-10  
5060-152-3-10

NOTES:

- ▷ THESE WIRES VENDOR FURNISHED
- ▷ OPTIONAL WITH POST LIGHTS INSTL

REVISION			
LET	DESCRIPTION	DATE	APPD

04-231-0305  
 03-231-0305

18	C669514-0101	INST CLUSTER
17	C669513-0101	INST CLUSTER
16	C669511-0102	INST CLUSTER
15	1270473-12	LIGHT ASSY
14	C669512-0102	INST CLUSTER
13	C669513-0102	INST CLUSTER
12	0511481	INST LT
11	071306B	COMPASS LT
10	S-1640-6	HOUSING
9	S-1641-6	HOUSING
8	1570166-1	DIMMING ASSY
7	S-1637-1	HOUSING
6	S-1637-2	HOUSING
5	1270479-10	LIGHT ASSY
4	S7000B270J	RESISTOR
3	S-2091-5	RESISTOR ASSY
2	34003-55	TERMINAL BOARD
1	S-1360-10L	CIRCUIT BREAKER

LB13	20	20	S-1635-1	S-1367-14
LB12	18	4	SOLDER	S-1367-10
LB11	20	48	S-1635-1	S-1635-1
LB10	20	76	S-1636-2	S-1636-1
LB9	20	29	S-1636-1	SEE LB15
LB8	18		S-1370-3	S-1829-1
LB14	18		S-1635-1	S-1829-1
LB5	18	15	SOLDER	S-1636-1
LB4	18	15	SOLDER	S-1635-1
LB3	18	3	S-1635-1	SEE LB2
LB2	18	13	SOLDER	SEE LB6
LB6	18	5	S-1367-16	S-1370-2

WIRE TABLE					
WIRE CODE NO	GA	MATERIAL	LG	TERMINALS	SERIALS

CONTRACT NO.			COMMERCIAL AIRCRAFT DIV. 5800 E. FAWNEE WICHITA, KANSAS		
DESIGN	G STAMM	DATE	Cessna AIRCRAFT CO.		
GROUP	B HADEN	1-2-75	TITLE		
DRAWN	MERRICK	10-31-74	WIRING DIAGRAM - COMPASS & INSTRUMENT LIGHTS		
CHECK	J. YOWEL	12-6-74			
STRESS					
PROJ	R. FIFE	1-4-75	SIZE	CODE IDENT.	DWG NO
APPD	RS-208		C	71379	0570101
OTHER			SCALE: NONE	(SRT503) (SRT504)	PAGE: 11.2.0

EQUIPMENT TABLE	
PART NO.	DESCRIPTION

CES-1000 IS APPLICABLE VENDOR CODES PER 8-1400 CES-XXXX-CESSNA SPEC. NO. 8-XXX OR CMXXXX-CESSNA STD. NO.	SUPERSEDES: 0500062 P11.2.A
	SUPERSEDED BY:



20-72 Change 3

NOTES:

- 1. SEE PG. 11.2.0 & PG. 11.2.1 FOR INSTRUMENT CLUSTER LIGHTS

REVISION			
LET	DESCRIPTION	DATE	APPD

500-152-90

WIRE CODE NO	GA	MATERIAL	LG	TERMINALS	SERIALS
RED/YEL	22	-22-2-4		SOLDER	SOLDER
BLK	22	-22-0		SOLDER	
LB24	22			S-1635-1	
LB23	22			S-1636-1	
LB22	22			S-1635-1	
LB21	22			S-1636-1	SOLDER
LB20	22			S-1635-1	S-13671-B
LB19	22			S-1635-1	S-13671-B
LB18	22			S-1636-2	S-1636-1
LB17	22			S-1636-1	SEE LB18
LB16	18			S-1635-2	S-1635-1
LB15	18			S-1636-1	S-1635-1
LB14	18			S-1636-1	SOLDER
LB13	18			S-1636-1	SOLDER

PART NO.	DESCRIPTION
9	051481 INST LT
8	S-1501-1 SWITCH
7	S-1641-6 HOUSING

PART NO.	DESCRIPTION
4	1213379-9 POST LT ASSY
3	S-1640-6 HOUSING
2	S-1637-2 HOUSING
1	S-1637-1 HOUSING

EQUIPMENT TABLE	
CES-1000 IS APPLICABLE VENDOR CODES PER S-400 CES-XXXX-CESNA SPEC. NO. S-XXX OR CMXXXX-CESNA STD. NO.	SUPERSEDES: P 11.2.5.1 05000062 P 11.2.5.0
	SUPERSEDED BY:

CONTRACT NO:		NAME		DATE
		G. STAMM		1-2-75
		B. HARDEN		1-2-75
		MERRICK		10-31-74
		J. YOUNG		12-6-74
		R. FIFE		1-4-75
		APPD		
		OTHER		

COMMERCIAL AIRCRAFT DIV.  
5800 E. PAWNEE  
WICHITA, KANSAS

Cessna AIRCRAFT CO.

TITLE  
**WIRING DIAGRAM—  
INSTRUMENT PANEL  
POST LIGHTING (OPT)**

SIZE	CODE IDENT. NO.	DWG NO
C	71379	0570101

SCALE: NONE (SRT204)(SRT903) PAGE: 11.3.0

REVISION			
LET	DESCRIPTION	DATE	APPD

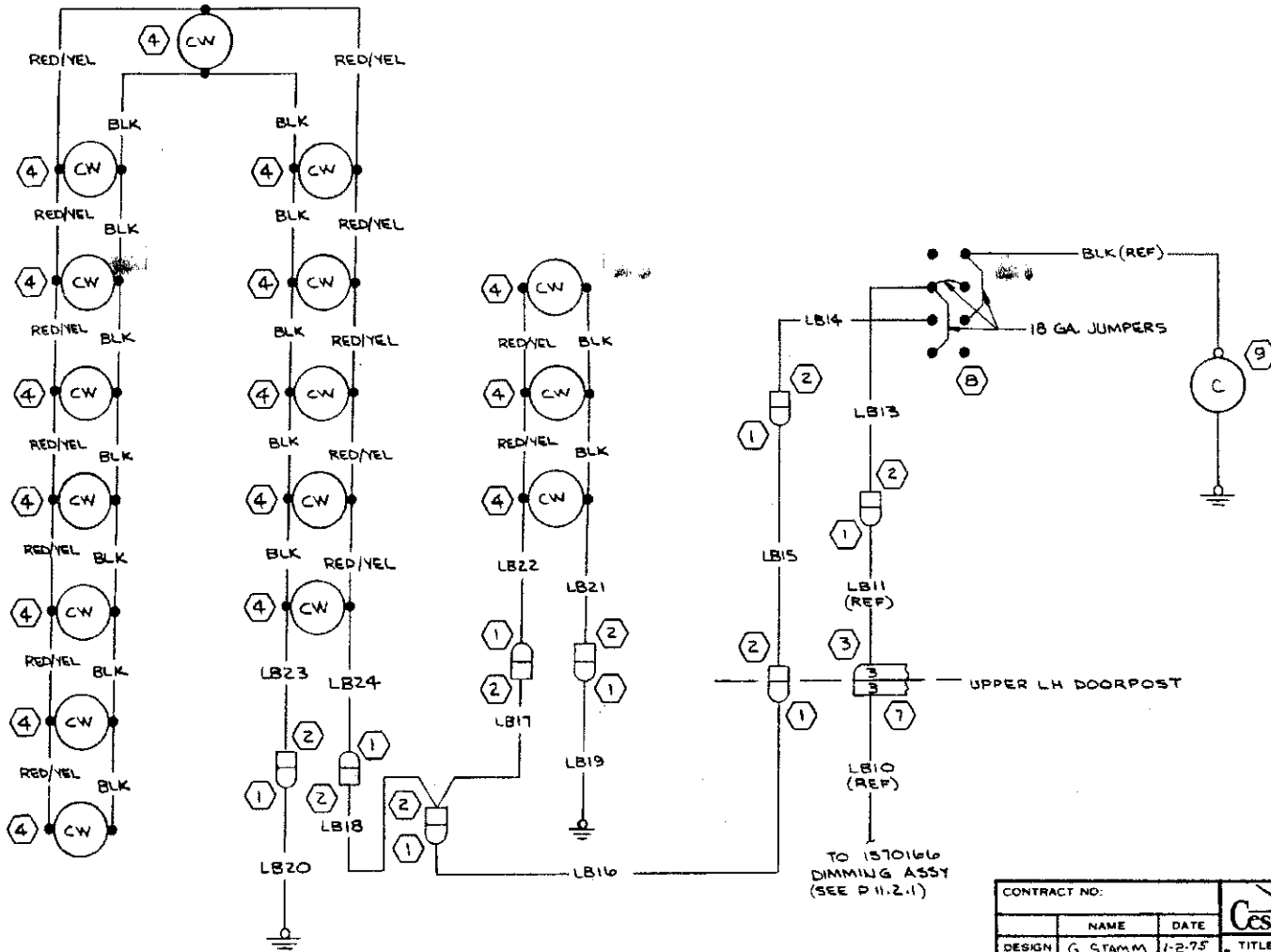

5060-132-10  
03-00

Change 3 20-73

FORM NO. 802164

CONTRACT NO:			PAWNEE DIVISION 5800 E. PAWNEE WICHITA, KANSAS		
DESIGN	G STAMM	1-2-75	 <b>WIRING DIAGRAM - INSTRUMENT PANEL POST LIGHTING (OPT)</b>		
GROUP	B HARDEN	5-2-75			
DRAWN	MERRICK	10-31-74			
CHECK	J YOEEL	12-6-74			
STRESS					
PROJ	C FIFE	1-4-74	SIZE	CODE IDENT. NO.	DWG NO.
APPD	08-2015		C	71379	0570101
OTHER			SCALE: NONE (SR7904) (SE7503) PAGE 11.3-1		

172, F172, F172L

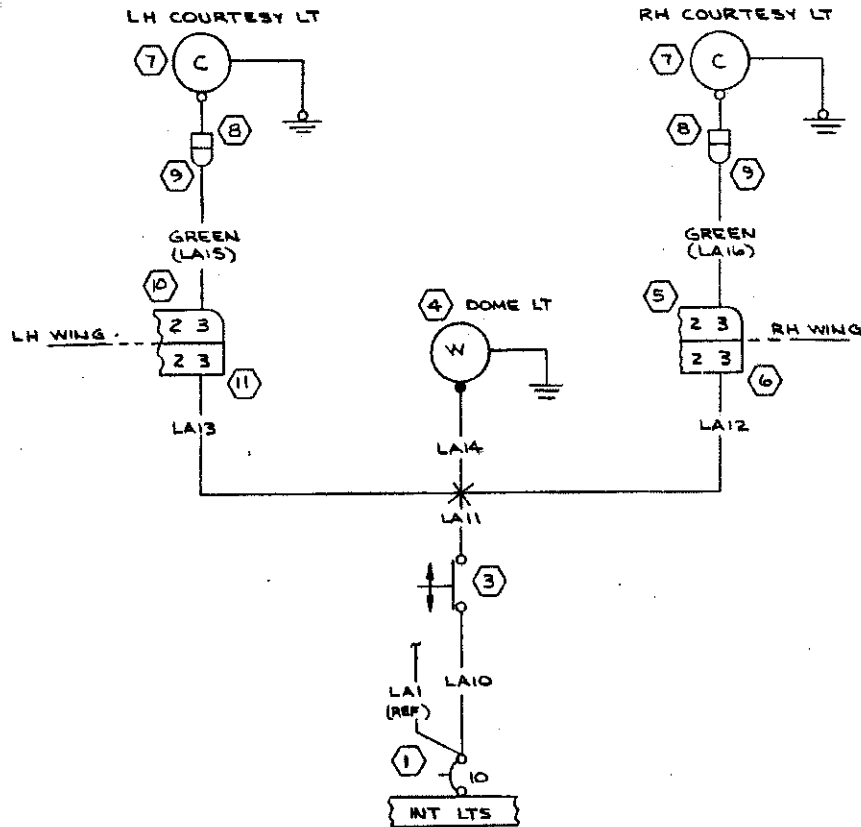

REVISION			
LET	DESCRIPTION	DATE	APPD

5060-137-50  
05-12-50

WIRE CODE NO	GA	MATERIAL	LG	TERMINALS	SERIALS
GREEN LA18	18	-18-5	117	S-1635-1	S-1635-1
GREEN LA19	18	-18-5	117	S-1635-1	S-1635-1
LA14			6	SOLDER	SEE LA11
LA13			45	S-1636-1	SEE LA11
LA12			45	S-1636-1	SEE LA11
LA11			6	S-1830-1	S-1310-3
LA10	18		84	S-1830-1	S-1367-6

PART NO.	DESCRIPTION
11	S-1641-6 HOUSING
10	S-1640-6 HOUSING
9	S-1637-1 HOUSING
8	S-1637-2 HOUSING
7	0521101 COURTESY LT
6	S-1641-9 HOUSING
5	S-1640-9 HOUSING
4	0311481 DOME LT ASSY
3	S-1831-1 SWITCH
1	S-1360-10L CIRCUIT BREAKER

**WIRE TABLE**

CONTRACT NO: \_\_\_\_\_

DESIGN: G. STAMM 12-74

GROUP: D. HARDEN 1-75

DRAWN: MERRICK 10-74

CHECK: J. YOWEL 2-6-74

STRESS: \_\_\_\_\_

PROJ: R FIFE 1-4-75

APPD: *JRS*

OTHER: \_\_\_\_\_

SIZE: C

CODE IDENT. NO: 71379

DWG NO: 0570101

SCALE: NONE

(S1903) (R1506) PAGE: 11-4-0

COMMERCIAL AIRCRAFT DIV.  
CESSNA AIRCRAFT CO.  
8800 E. PAWNEE  
WICHITA, KANSAS

**WIRING DIAGRAM -  
DOME & COURTESY LIGHTS**

**EQUIPMENT TABLE**

CEB-1000 IS APPLICABLE  
VENDOR CODES PER S-1400  
CEB-XXXX-CESSNA SPEC. NO.  
S-XXX OR CXXXX-CESSNA  
STD. NO.

SUPERSEDES:  
0500062 P 11.7.1

SUPERSEDED BY:



REVISION			
LET	DESCRIPTION	DATE	APPD
A	BY REV: EXCHANGE TAXI LT & LDG LT, TAN(LC2) & GRAY(LC2), LE1 & LC1, LE4 & LC5 (SR7303)(SR7904)	TMS 3-10-75	431011 /R/S KJ

5060-132-60  
5060-132-60

WIRE CODE NO	GA	MATERIAL	LG	TERMINALS	SERIALS
LC5	12		5-1493-3	5-13671-6	
LE4	12		5-1493-3	5-13671-6	
BLK WHT LE3	12	-12-0-9	6	5-13673-8	5-13673-8
GRY LE3		-12-8	36	5-1493-3	5-13673-8
LE1			50	5-1493-3	5-1493-3
BLK WHT LC4		-12-0-9	28	5-1493-3	5-13673-8
BLK WHT LC3		-12-0-9	33	5-13673-8	5-1493-3
GRY LC3		-12-10	32	5-1493-3	5-13673-8
LC1	12		50	5-1493-3	5-1493-3

PART NO.	DESCRIPTION
6	5-2160-5 SWITCH
5	4509 LAMP
4	5-2064-1 CONNECTOR
3	5-2160-4 SWITCH
1	5-1360-20L CIRCUIT BREAKER

**EQUIPMENT TABLE**

CES-1000 IS APPLICABLE  
VENDOR CODES PER S-1400  
CES-XXXX-CESSNA SPEC. NO.  
S-XXX OR CMXXXX-CESSNA  
STD. NO.

SUPERSEDES:  
25-00062 P11.3.3

SUPERSEDED BY:

CONTRACT NO.			Cessna AIRCRAFT CO.		
DESIGN	NAME	DATE	COMMERCIAL AIRCRAFT DIV. 3800 E. PAWNEE WICHITA, KANSAS		
GROUP	G. STAMM	12/74	TITLE		
DRAWN	MENKICK	10/3/74	WIRING DIAGRAM -		
CHECK	TOWSEL	12-6-74	LANDING & TAXI LIGHT		
STRESS			(OPT)		
PROJ			SIZE	CODE IDENT NO.	DWG NO.
APPD			C	71379	0570101
OTHER			SCALE	TIME	PAGE: 11.5.0

REVISION			
LET	DESCRIPTION	DATE	APPD
A	FOR REVISION SEE SHEET 11.5.0		

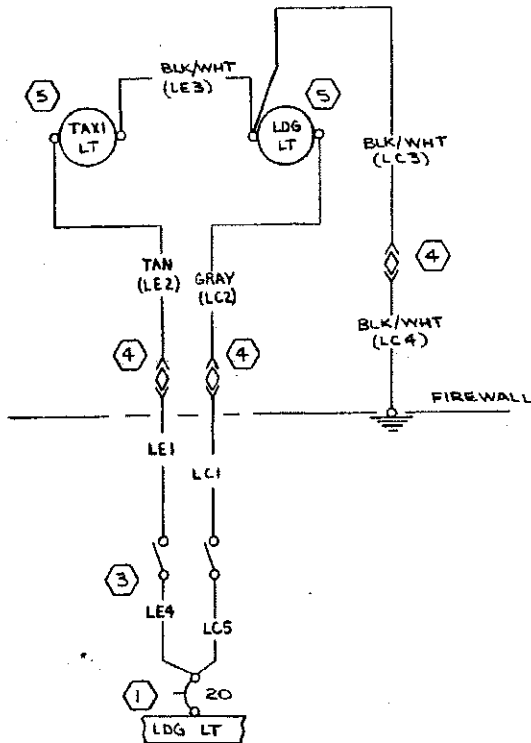

APPLICABLE TO FITZ,FR172 &  
ALTERNATE OPTION ON 172

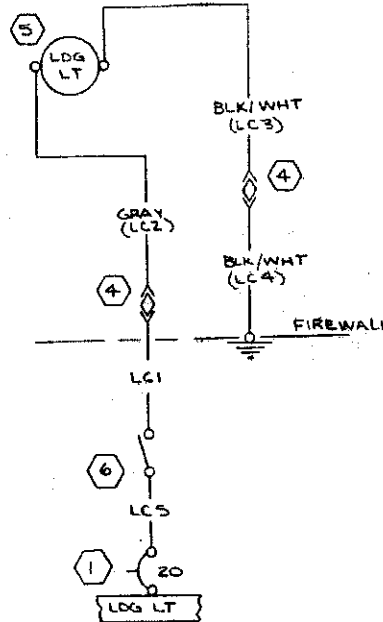

APPLICABLE TO 172 ONLY

5050-152-00  
5050-152-10

CONTRACT NO.			FAWNEE DIVISION 5800 E. FAWNEE WICHITA, KANSAS	
DESIGN	G. STAMM	12/74	Cessna AIRCRAFT CO.	
GROUP	B. HARDEN	1-2-75	TITLE	
DRAWN	MERRICK	10-3-74	WIRING DIAGRAM	
CHECK	J. YOUNG	11-6-74	LANDING & TAXI LIGHT	
STRESS			(OPT)	
PROJ	P. HILL	1/1/75	SIZE	CODE IDENT
APPD	J. R. H. HARRIS		C	71379
OTHER			DWG NO.	0570101
			SCALE: NONE	(SR7903) (SR1204) PAGE: 11.5.1

172, F172, FR172



REVISION			
LET	DESCRIPTION	DATE	APPD

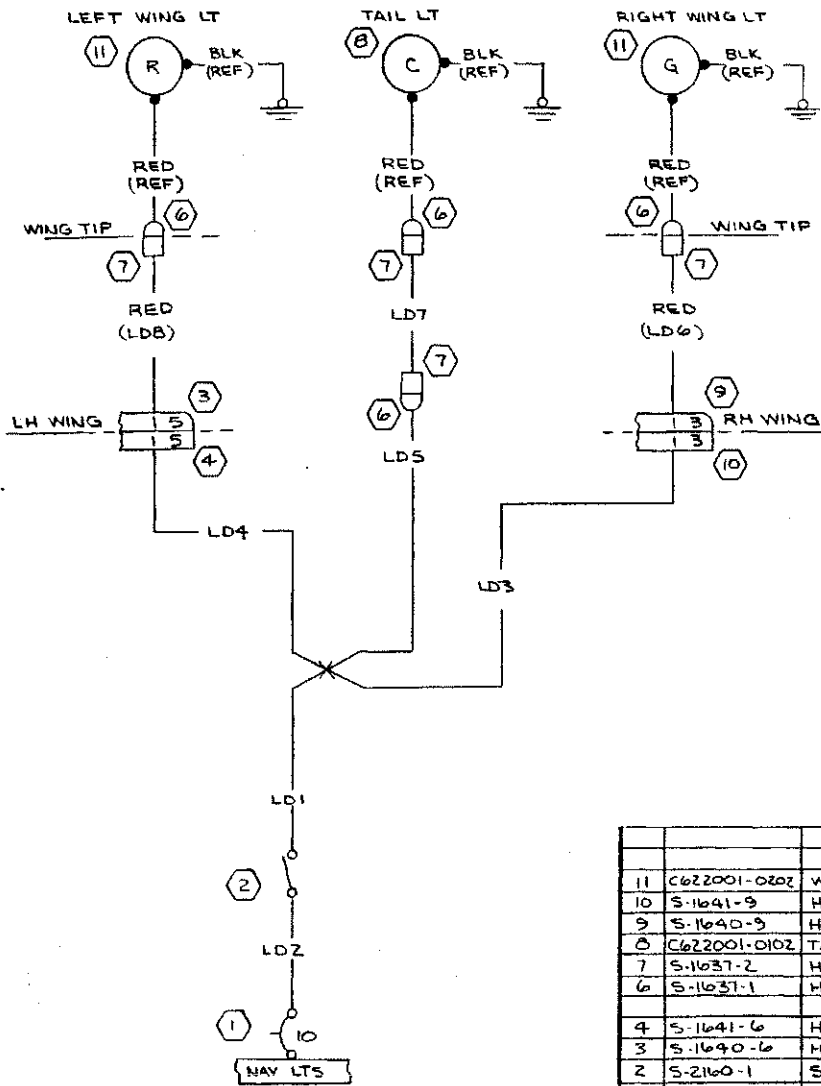

04-237-0905  
03-231-0905

PART NO.	DESCRIPTION
11	C622001-0202 WING LIGHT
10	S-1641-9 HOUSING
9	S-1640-9 HOUSING
8	C622001-0102 TAIL LIGHT
7	S-1637-2 HOUSING
6	S-1637-1 HOUSING
4	S-1641-6 HOUSING
3	S-1640-6 HOUSING
2	S-2160-1 SWITCH
1	S-1360-10L CIRCUIT BREAKER

EQUIPMENT TABLE	
CES-1000 IS APPLICABLE	SUPERSEDES: 0500062 P11.9.1
VENDOR CODES PER S-1400	SUPERSEDED BY:
CES-XXXX-CESNA SPEC. NO.	
S-XXX OR CMXXXX-CESNA	
STD. NO.	

WIRE CODE NO	GA	MATERIAL	LG	TERMINALS	SERIALS
RED 18	-18-2	200	S-1635-1	S-1636-1	
LD7		290	S-1636-1	S-1636-1	
RED 18	-18-2	200	S-1635-1	S-1636-1	
LD5		18	S-1370-2	S-1635-1	
LD4		40	SEE LDB	S-1636-1	
LD3	18	60	SEE LDB	S-1636-1	
LD2	18		S-1493-1	S-1367-1-6	
LD1	18	6	S-1493-1	SEE LDS	

WIRE TABLE		
CONTRACT NO:		
DESIGN	G. STAMM	18-74
GROUP	B. HARDEY	1-2-75
DRAWN	MERRICK	10-3-74
CHECK	J. YOEEL	12-6-74
STRESS		
PROJ	P. H. F.	1-9-75
APPD		
OTHER		
SIZE		
CODE IDENT. NO.	C 71379	
DWG NO.		0570101
SCALE: NONE	(S19)03 (S19)04	PAGE: 11.6.0

COMMERCIAL AIRCRAFT DIV.  
5800 E. PAWNEE  
WICHITA, KANSAS

**Cessna AIRCRAFT CO.**

TITLE  
**WIRING DIAGRAM -  
NAVIGATION LIGHTS**

172, F172, FR172



Change 3 20-77

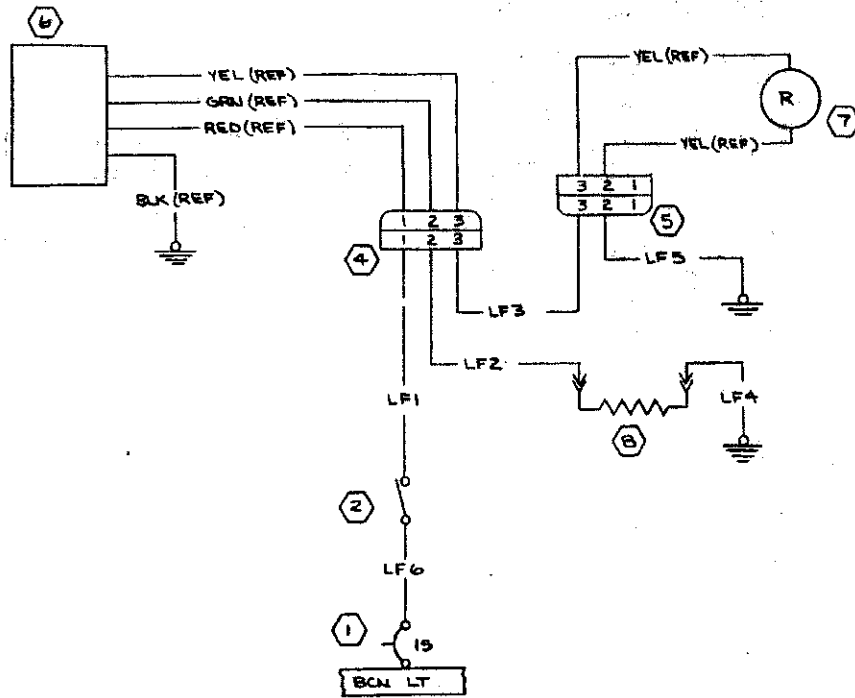

REVISION			
LET	DESCRIPTION	DATE	APPD
A	BY REV: S-1367-2-B WAS S-1367-2-6 PER LF4 S-1367-2-6 WAS S-1367-2-B PER LFS (SR1903) (SR1904)	RS 2-6-75	SCA WNB RKS RF
B	BY REV: S-1360-15L WAS S-1360-10L; LFI & LF6/16 GA WIRE WAS 18 GA (SR7903) (SR7904)	BAH 5-13-75	RAM Lob RF

5080-117-00  
5060-112-90

PART NO.	DESCRIPTION
8	OR95-1.5 RESISTOR
7	C621001-0106 LIGHT ASSY
6	C594502-0101 FLASHER ASSY
5	S-1638-2 HOUSING
4	S-1638-1 HOUSING
2	S-2100-1 SWITCH
1	S-1360-15L CIRCUIT BREAKER

EQUIPMENT TABLE	
CES-1000 IS APPLICABLE VENDOR CODES PER S-1400 CES-XXXX-CESNA SPEC. NO. S-XXX OR CXXXX-CESNA STD. NO.	SUPERSEDES: 0500062 P11.10-2 SUPERSEDED BY:

WIRE CODE NO	GA	MATERIAL	LG	TERMINALS	SERIALS
LF6	16			S-1493-2 S-1367-24	
LF5	18		4	S-1635-2 S-1367-26	
LF9	18		8	S-1493-2 S-1367-28	
LF3	18	60		S-1635-2 S-1636-2	STD
LF2	18	8		S-1493-2 S-1636-2	
LF1	16	250		S-1493-2 S-1635-2	STD

CONTRACT NO:		NAME		DATE	Cessna AIRCRAFT CO.		COMMERCIAL AIRCRAFT DIV. 8000 E. PAWNEE WICHITA, KANSAS	
DESIGN	G. STAMM	12-74			TITLE			
GROUP	B. HARDEY	1-2-75			WIRING DIAGRAM -			
DRAWN	MERRICK	10-11-75			LIGHT-FLASHING BEACON			
CHECK	J. YOWEL	7-6-79			(OPT)			
STRESS								
PROJ	R. FIFE	1-4-75			SIZE	CODE IDENT. NO.	DWG NO.	
APPD	RKS				C	71379	0570101	
OTHER					SCALE: NONE	(SR1903) (SR1904)	PAGE: 11.7.0	

REVISION			
LET	DESCRIPTION	DATE	APPD

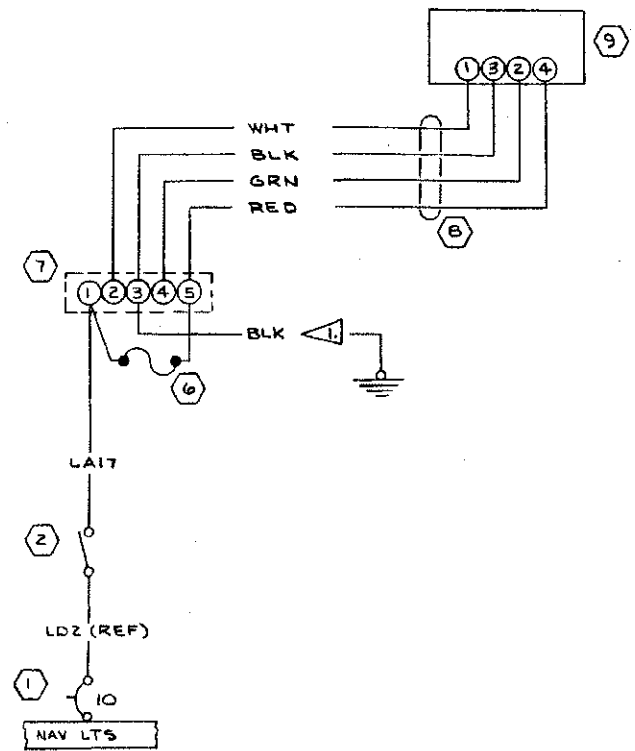

5065-132-10  
04-79

**NOTES:**

- 1. THIS WIRE NOT REQUIRED WHEN BOOM MIKE IS INSTALLED, REFER TO 0510400 PAGE 2.35 FOR REPLACEMENT WIRING WHEN BOOM MIKE IS INSTALLED
- 2. VENDOR FOR 320733 & 329626 IS (00779)  
VENDOR FOR 8409 IS (70903)  
VENDOR FOR 35111-05-001 IS (71785)

ITEM NO.	FART NO.	DESCRIPTION
9	0570088-1	MAP LIGHT ASSY
8	8409	CABLE
7	35111-05-001	TERMINAL STRIP
6	1570141-1	FUSE ASSY
2	5-2160-1	SWITCH
1	5-1360-10L	CIRCUIT BREAKER

WIRE CODE NO	GA	MATERIAL	LG	TERMINALS	SERIALS
WHT	20	B409	320733	320733	
BLK	20	B409	320733	320733	
GRN	20	B409	320733	320733	
RED	20	B409	320733	320733	
LA17	20	5-1360-10L	329626		

CONTRACT NO:		Cessna AIRCRAFT CO.		COMMERCIAL AIRCRAFT DIV. 8800 E. PAWNEE WICHITA, KANSAS	
DESIGN	G. STAMM	DATE	12-76	TITLE	
GROUP	B. HARDEN	DATE	1-2-75	WIRING DIAGRAM -	
DRAWN	MERRICK	DATE	03-74	MAP LIGHT - CONTROL WHEEL	
CHECK	J. YOUNG	DATE	12-6-74	(OPT)	
STRESS					
PROJ	R. HILL	DATE	4-75	SIZE	CODE IDENT.
APPD				C	71379
OTHER				DWG NO.	0570101
SCALE: NONE			(SR1503)	(SR7904)	PAGE: 11.8.0

Change 3 20-79

20-80 Change 3

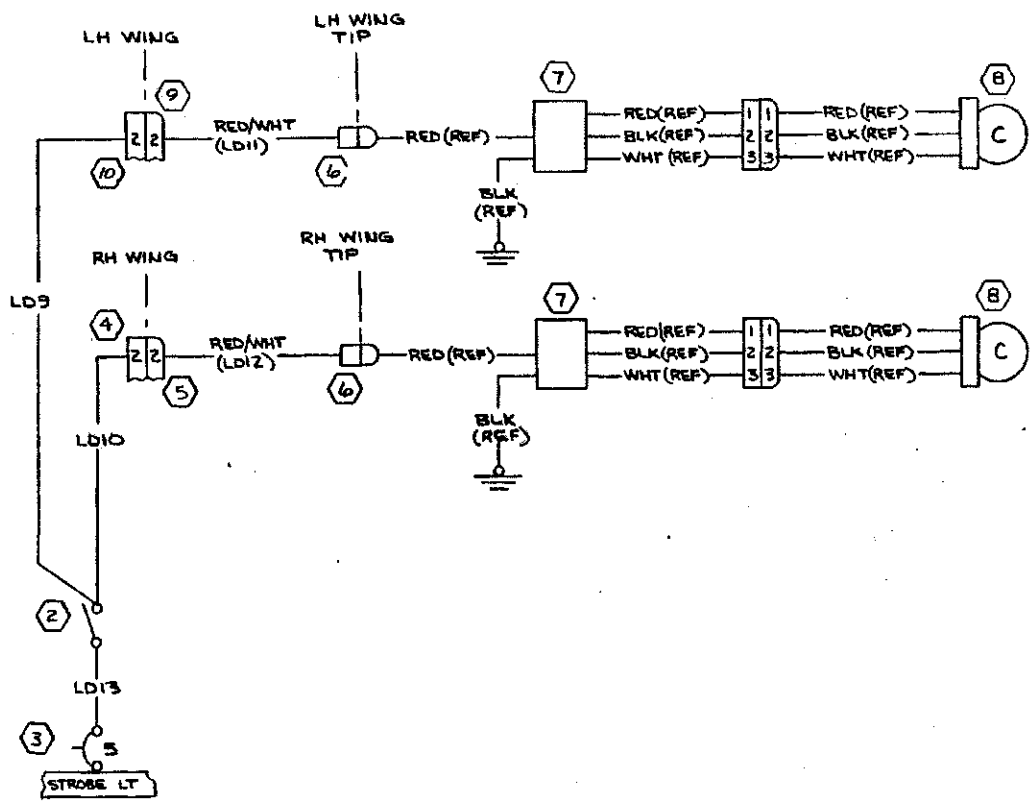

REVISION			
LET	DESCRIPTION	DATE	APPO

5005-152-00  
04-721-0005

WIRE	GA	MATERIAL	LG	TERMINALS	SERIALS
LD13	22				
LD15	22				
LD11	22				
LD12	22				
LD10	22				
LD9	22				

PART NO.	DESCRIPTION
10	S-1641-6 HOUSING
9	S-1640-6 HOUSING
8	C622006-001 LAMP ASSY
7	C622007-001 POWER ASSY
6	S-1637-2 HOUSING
5	S-1640-5 HOUSING
4	S-1641-5 HOUSING
3	S-1360-SL CIRCUIT BREAKER
2	S-2160-1 SWITCH

CONTRACT NO:			COMMERCIAL AIRCRAFT DIV. 3900 E. PAWNEE WICHITA, KANSAS		
DESIGN	G. STAMM	1/4-74	TITLE		
GROUP	D. HADDEN	1-2-75	WIRING DIAGRAM -		
DRAWN	MERRICK	10-3-74	WING TIP STROBE LIGHT		
CHECK	J. YUCEL	11-4-74	(OPT)		
STRESS			PROJ	R. FIFE	1-4-75
			APPD	1/22-203	
			OTHER		
EQUIPMENT TABLE			SIZE	CODE IDENT. NO.	DWG NO.
CES-1000 IS APPLICABLE VENDOR CODES PER S-1600 CES-1100-CESNA SPEC. NO. S-100 OR CM1000-CESNA STD. NO.			C	71379	0570101
SUPERSEDES: 050006Z P 11-14-72			SCALE: NONE		
SUPERSEDED BY:			PAGES: 1 OF 1		

FORM NO. 80-2108

172, F172, F172Z



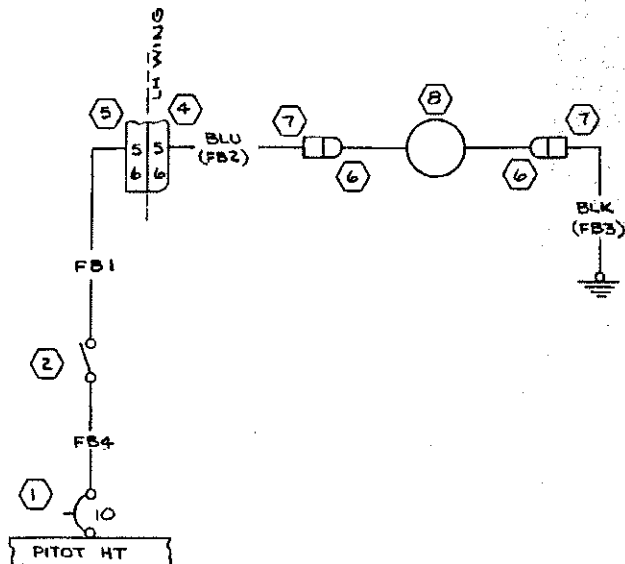

REVISION			
LET	DESCRIPTION	DATE	APPD

5050-112-10  
5060-10905

ITEM NO	PART NO.	DESCRIPTION
8	0721105	PITOT HEATER
7	S-1637-2	HOUSING
6	S-1637-1	HOUSING
5	S-1641-6	HOUSING
4	S-1640-6	HOUSING
2	S-2160-1	SWITCH
1	S-1360 -10L	CIRCUIT BREAKER

**EQUIPMENT TABLE**

CEB-1000 IS APPLICABLE  
VENDOR CODES PER 8-1400  
CEB-XXXX-CESSNA SPEC. NO.  
8-XXX OR CMXXXX-CESSNA  
STD. NO.

**SUPERSEDES:**  
050006Z P 13.1

**SUPERSEDED BY:**

WIRE CODE NO	GA	MATERIAL	LG	TERMINALS	SERIALS
FB4	18			S-1493-1 S-1367-1-6	
BLK FB3	18	-18-0	14	S-1636-2 S-1367-1-8	
BLU FB2	18	-16-6	48	S-1636-2 S-1636-2 (STD)	
FB1	18		48	S-1493-1 S-1635-2	

**WIRE TABLE**

CONTRACT NO: \_\_\_\_\_

DESIGN: G. STAMM 12-74  
GROUP: B. HARDEW 1-2-75  
DRAWN: MERRICK 10-31-74  
CHECK: J. YQUEL 12-6-74  
STRESS: \_\_\_\_\_

PROJ: R. FIFE 1-4-75  
APPD: [Signature] 5-20  
OTHER: \_\_\_\_\_

COMMERCIAL AIRCRAFT DIV.  
CESSNA AIRCRAFT CO.  
8800 E. PAWNEE  
WICHITA, KANSAS

TITLE: **WIRING DIAGRAM -  
PITOT - HEATED  
(OPT)**

SIZE: C  
CODE IDENT. NO.: 71379  
DWG NO.: 0570101

SCALE: NONE (S-1503) (S-17904) PAGE: 13.2.0





REVISION			
LET	DESCRIPTION	DATE	APPD

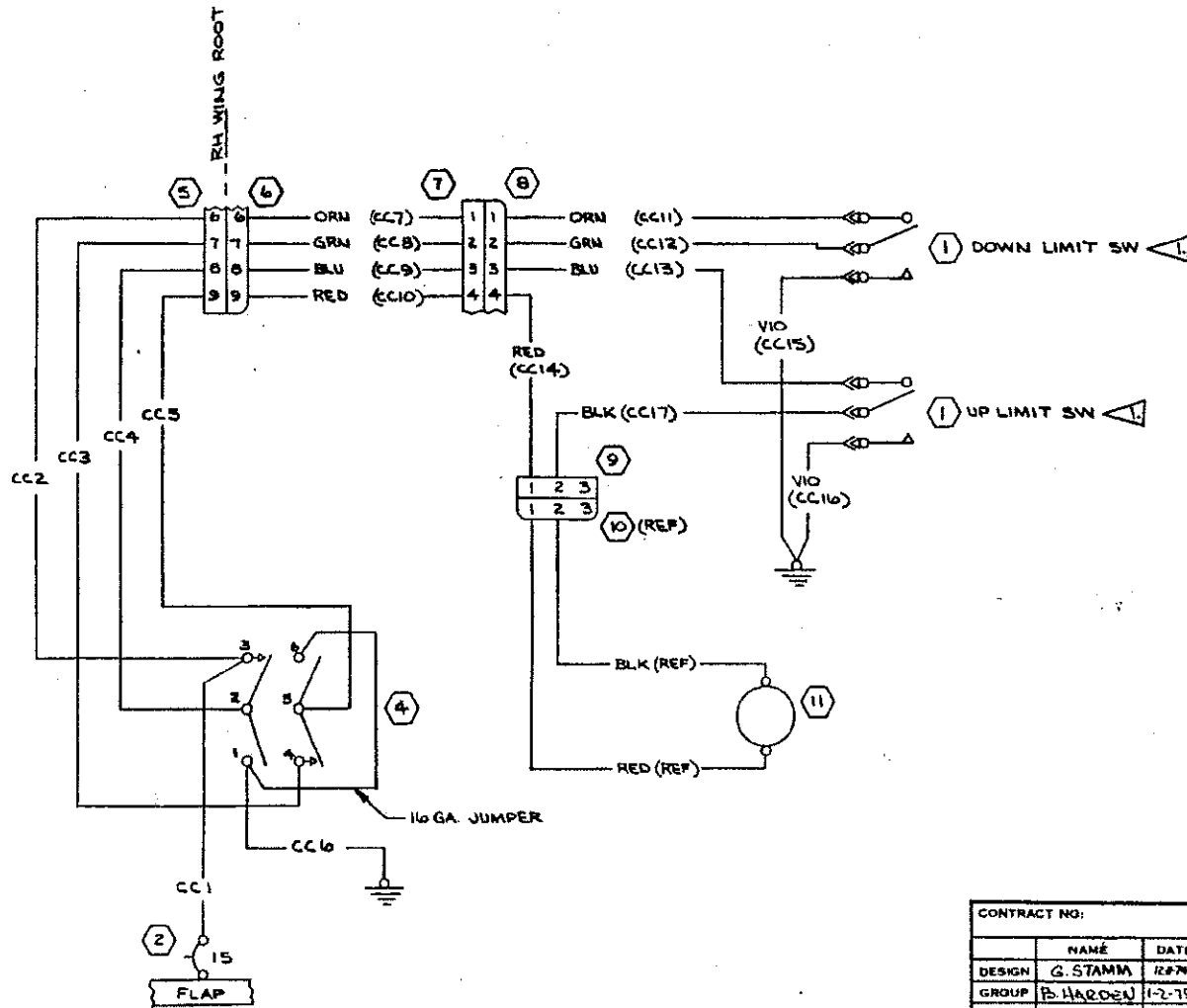

5050-182-10  
5050-182-10

CONTRACT NO:			PAWNEE DIVISION 8800 E. PAWNEE WICHITA, KANSAS		
DESIGN	NAME	DATE	Cessna AIRCRAFT CO.		
GROUP	B. STAMM	12-74	TITLE		
DRAWN	MERRICK	10-31-74	WIRING DIAGRAM -		
CHECK	J. YOUNG	12-6-74	WING FLAPS -		
STRESS			ELECTRIC		
PROJ	R. FIFE	1-4-75	SIZE	CODE IDENT NO.	DWG NO.
APPD	APC/ASB		C	71379	0570101
OTHER			SCALE: NONE (SR7505) (SR7506) PAGE: 14.1		



REVISION			
LET	DESCRIPTION	DATE	APPD

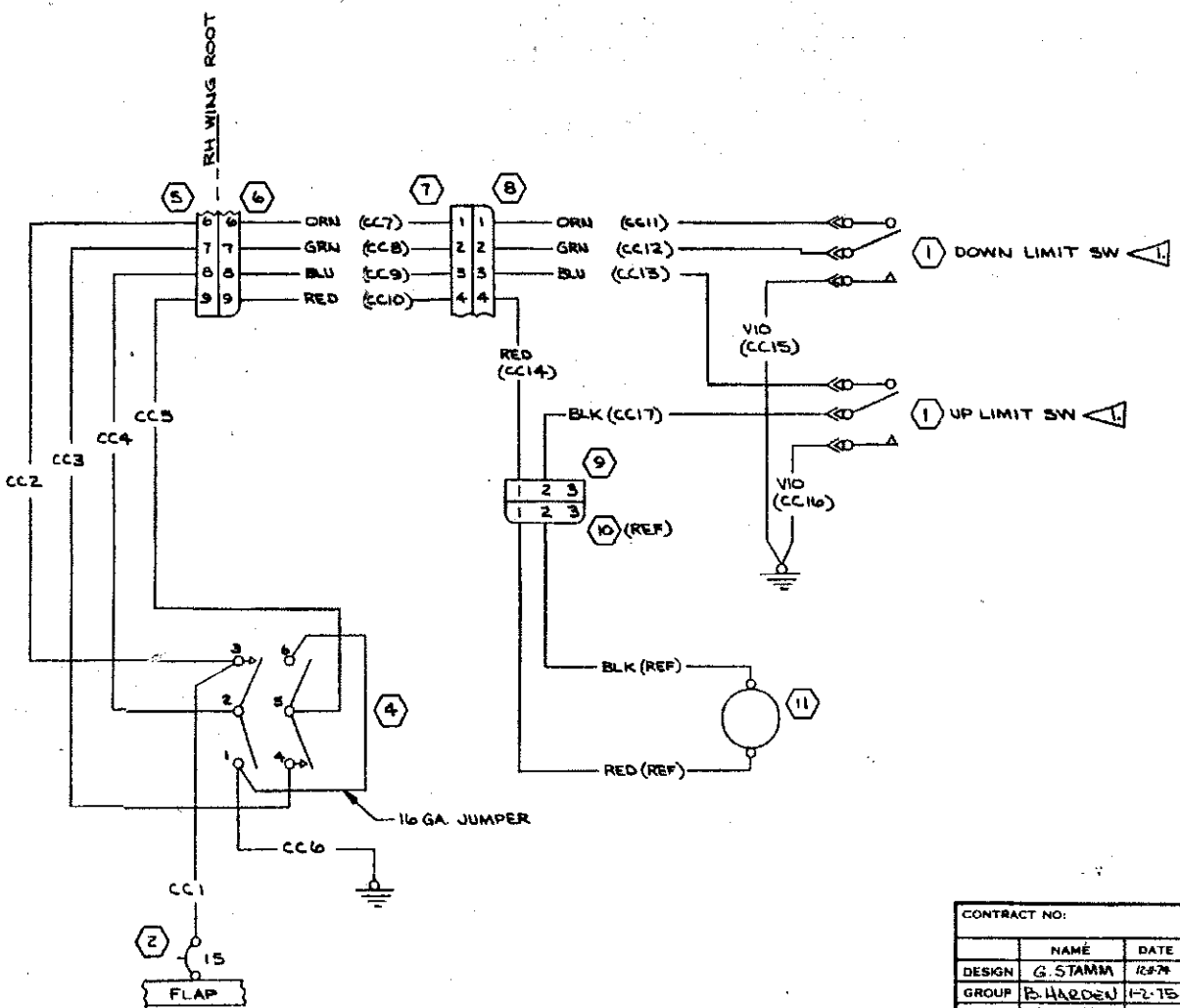

5060-152-00  
5060-152-40

CONTRACT NO:		PAWNEE DIVISION 8800 E. PAWNEE WICHITA, KANSAS	
DESIGN	G. STAMM	DATE	12-79
GROUP	B. HAROLD	DATE	12-75
DRAWN	MERRICK	DATE	10-2-74
CHECK	J. YOWEL	DATE	12-6-74
STRESS			
PROJ	R. FIFE	DATE	1-4-75
APPD	ASB		
OTHER			
TITLE		SIZE	CODE IDENT. DWG NO.
WIRING DIAGRAM - WING FLAPS - ELECTRIC		C	71379 0570101
SCALE: NONE		(SR1905) (SR1906)	PAGE: 14.1.1

REVISION			
LET	DESCRIPTION	DATE	APPD

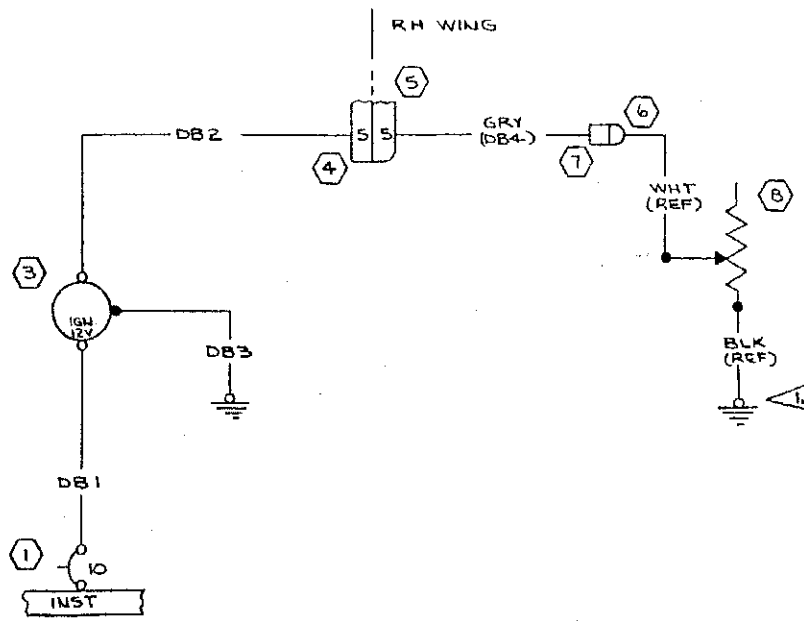

NOTES :

▲ GROUND BLACK WIRE ON TRANSMITTER MOUNTING BOLT

ITEM NO.	PART NO.	DESCRIPTION
8	C590501-0101	FLAP POSITION XMTR
7	S-1637-2	HOUSING
6	S-1637-1	HOUSING
5	S-1640-9	HOUSING
4	S-1641-9	HOUSING
3	C1668001-0106	FLAP POSITION IND

ITEM NO.	PART NO.	DESCRIPTION
1	S-1360-10L	CIRCUIT BREAKER

CES-1000 IS APPLICABLE VENDOR CODES PER S-1400 CES-XXXX-CESNA SPEC. NO. S-XXX OR CMXXXX-CESNA STD. NO.

SUPERSEDES: 0500062 P14.73  
SUPERSEDED BY:

WIRE CODE NO.	GA	MATERIAL	LG	TERMINALS	SERIALS
DB3	18	-18-8	100	S-1635-1 S-1636-1	
DB2	22		24	S-1367-1L S-1367-1R	
DB1	22		30	S-1367-1L S-1367-1R	

CONTRACT NO. \_\_\_\_\_

Cessna AIRCRAFT CO. COMMERCIAL AIRCRAFT DIV. 5800 E. PAWNEE WICHITA, KANSAS

DESIGN G. STAMM DATE 1-2-75  
GROUP B HARDEY  
DRAWN MERRICK 10-3-74  
CHECK J. YOWEL 12-6-74

TITLE WIRING DIAGRAM - FLAP POSITION INDICATOR

STRESS \_\_\_\_\_  
PROJ R. FIFE 1-4-75  
APPD J. P. [Signature]  
OTHER \_\_\_\_\_

SIZE C CODE IDENT NO. 71379 DWG NO. 0570101  
SCALE: NONE (SRT903) (SRT904) PAGE: 14.2.0

Change 3 20-85/(20-86 blank)

5800-182-1-00  
5800-182-1-00



REVISION			
LET	DESCRIPTION	DATE	APPO

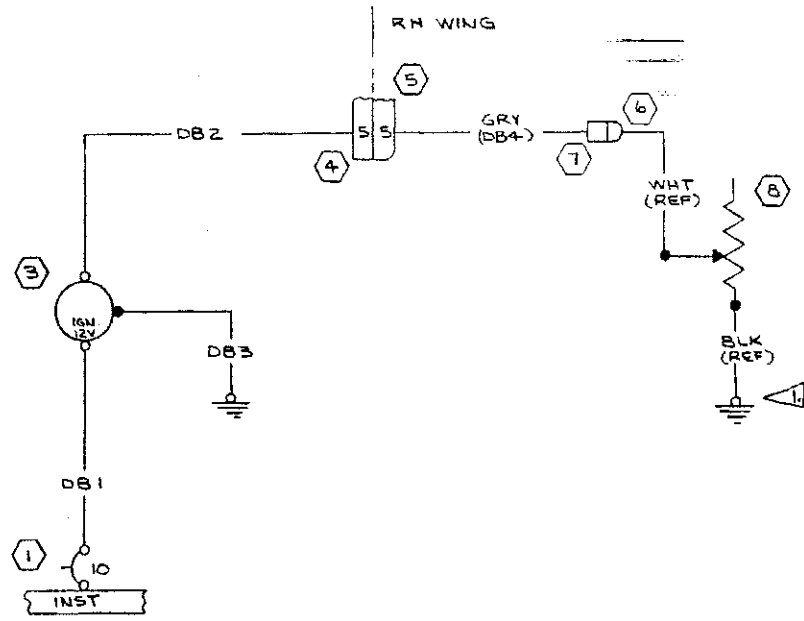

5050-152-50  
600-152-50

**NOTES :**

⚠️ GROUND BLACK WIRE ON TRANSMITTER MOUNTING BOLT

ITEM NO	PART NO.	DESCRIPTION
8	C580501-0101	FLAP POSITION XMTR
7	S-1637-2	HOUSING
6	S-1637-1	HOUSING
5	S-1640-9	HOUSING
4	S-1641-9	HOUSING
3	C668001-0106	FLAP POSITION IND
1	S-1360-10L	CIRCUIT BREAKER

**EQUIPMENT TABLE**

CES-1000 IS APPLICABLE  
VENDOR CODES PER S-1400  
CES-XXXX-CESNA SPEC. NO.  
S-XXX OR CMXXXX-CESNA  
STD. NO.

SUPERSEDES:  
0500062 P14.7.3

SUPERSEDED BY:

WIRE CODE NO	GA	MATERIAL	LG	TERMINALS	SERIALS
GRY DB4	18	-18-8	100	S-1635-1 S-1636-1	
DB3	18		24	S-1367-1-6 S-1367-1-10	
DB2	22		52	S-1367-1-10 S-1636-1	
DB1	22		30	S-1367-1-10 S-1367-1-6	

**WIRE TABLE**

CONTRACT NO:

DESIGN	G. STAMM	DATE	12-74
GROUP	B HARDEV	DATE	1-2-75
DRAWN	MERRICK	DATE	10-3-74
CHECK	J. YOUNG	DATE	12-6-74
STRESS			

**Cessna AIRCRAFT CO.**  
COMMERCIAL AIRCRAFT DIV.  
5800 E. PAWNEE  
WICHITA, KANSAS

TITLE: **WIRING DIAGRAM —  
FLAP POSITION INDICATOR**

PROJ	R. FIFE	DATE	1-4-75
APPD	186-218		
OTHER			

SIZE: C  
CODE IDENT NO: 71379  
DWG NO: 0570101

SCALE: NONE  
(S47903) (SRT904) PAGE: 14.2.0

Change 3 20-85/(20-86 blank)





REVISION			
LET	DESCRIPTION	DATE	APPD

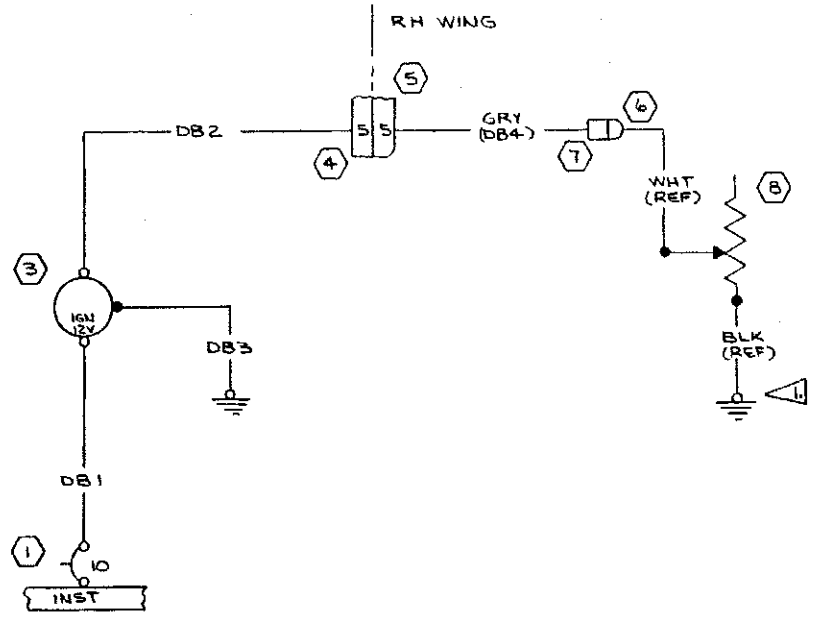

5060-122-20  
5060-122-20

**NOTES :**

▲ GROUND BLACK WIRE ON TRANSMITTER MOUNTING BOLT

PART NO.	DESCRIPTION
8 C590501-0101	FLAP POSITION XMT
7 S-1637-2	HOUSING
6 S-1637-1	HOUSING
5 S-1640-9	HOUSING
4 S-1641-9	HOUSING
3 C668001-0106	FLAP POSITION IND
1 S-1360-10L	CIRCUIT BREAKER

CES-1000 IS APPLICABLE  
VENDOR CODES PER S-1400  
CES-XXXX-CESNA SPEC. NO.  
S-XXX OR CMXXXX-CESNA  
STD. NO.

SUPERSEDES:  
050006Z P14.73  
SUPERSEDED BY:

WIRE CODE NO.	G/A	MATERIAL	LG	TERMINALS	SERIALS
DB2	18	-18-B	100	S-1635-1	S-1636-1
DB3	18		24	S-1367-1L	S-1367-1H
DBZ	22		52	S-1367-1H	S-1636-1
DB1	22		30	S-1367-1H	S-1367-1H

CONTRACT NO:		COMMERCIAL AIRCRAFT DIV. 5800 E. PAWNEE WICHITA, KANSAS	
DESIGN	G. STAMM	DATE	11-74
GROUP	B. HARDEY	DATE	1-2-75
DRAWN	MERRICK	DATE	10-3-74
CHECK	J. YOUNG	DATE	12-6-74
STRESS			
PROJ	R. FIFE	DATE	1-4-75
APPD	<i>[Signature]</i>		
OTHER			
SIZE	C	CODE IDENT. NO.	71379
DWG NO.		0570101	
SCALE: NONE		(SR7953) (SR7906)	PAGE: 14.2.0

Change 3 20-85/(20-86 blank)

