

SECTION XIV

ACCESSORIES AND UTILITIES

Paragraph		Aerofiche Grid No.
14-1.	Introduction	5H16
14-2.	Oxygen System	5H17
14-3.	Description and Principles of Operation	5H17
14-4.	Troubleshooting	5H17
14-5.	Safety Precautions	5H17
14-6.	Inspection and Overhaul Time Limits	5H17
14-7.	Testing for Leaks	5H18
14-8.	Maintenance	5H18
14-9.	Cleaning Operations	5H24
14-10.	Removal of Oxygen Cylinder and Regulator	5H24
14-11.	Installation of Oxygen Cylinder and Regulator	5I1
14-12.	Removal of Oxygen Cylinder Recharge Valve	5I2
14-13.	Installation of Oxygen Cylinder Recharge Valve	5I3
14-14.	Removal of Pressure Gauge	5I3
14-15.	Installation of Pressure Gauge	5I3
14-16.	Removal of Outlets	5I4
14-17.	Installation of Outlets	5I4
14-18.	Purging Oxygen System	5I4
14-19.	Cleaning of Face Masks	5I4
14-20.	Propeller De-Icer System	5I5
14-21.	Description and Principles of Operation	5I5
14-22.	De-Icer System Operational Check	5I10
14-23.	Inspection	5I10
14-24.	Fifty-Hour Inspection	5I10
14-25.	One-Hundred Hour Inspection	5I12
14-26.	Troubleshooting	5I15
14-27.	Helpful Hints	5I15
14-28.	Using Ammeter	5I16
14-29.	Timer Test	5I16
14-30.	De-Icer Resistance Check	5I17
14-31.	Brush Block Resistance Check	5I17
14-32.	Overall Procedures	5J1
14-33.	Use of Correct Parts	5J1
14-34.	Electrical	5J1
14-35.	Mechanical	5J2
14-36.	Balancing Weights	5J2
14-37.	Propeller Markings	5J2
14-38.	Switch, Circuit Breaker, Ammeter, Timer, Harness	5J2
14-39.	Brushes	5J2

Paragraph		Aerofiche Grid No.
14-40.	Brush Replacement as Sub-Assembly (PA-23-250; PA-23-235; and PA-23-250 [six place], Serial Nos. 27-2000 to 27-2504 incl.)	5J3
14-41.	Brush Replacement as Sub-Assembly (PA-23-250 [six place], Serial Nos. 27-2505 and up)	5J4
14-42.	Replacing Individual Brushes (PA-23-250; PA-23-235; and PA-23-250 [six place], Serial Nos. 27-2000 to 27-2504 incl.)	5J5
14-43.	Replacing Individual Brushes (PA-23-250 [six place], Serial Nos. 27-2505 and up)	5J6
14-44.	Alignment and Run-In of New Brushes	5J6
14-45.	Modular Brush Assembly Replacement for Brush Block Assembly	5J7
14-46.	Modular Brush Assembly Maintenance	5J7
14-47.	Slip Rings	5J9
14-48.	Machining	5J9
14-49.	Replacement	5J9
14-50.	Torque Limits	5J9
14-51.	Alignment	5J10
14-52.	Eccentric Running	5J10
14-53.	Blade De-Icers	5J10
14-54.	Replacement	5J10
14-55.	Cementing Procedure	5J11
14-56.	Blade De-Icer Surface, Outboard of Clamp	5J12
14-57.	Blade De-Icer Lead Strap	5J13
14-58.	Spinner Dome Strip	5J13
14-59.	Clamp Sponge Cushion	5J14
14-60.	Wrinkled De-Icers	5J14
14-61.	Installation of De-Icer Straps and Wire Harness	5J15
14-62.	Other Components	5J15
14-63.	Pneumatic De-Icer System	5J17
14-64.	Introduction	5J17
14-65.	Description and Principles of Operation	5J17
14-66.	System Troubleshooting	5J22
14-67.	System Checkout	5J22
14-68.	Electrical Test	5J22
14-69.	Vacuum Regulator Adjustment	5J23
14-70.	Component Maintenance and Replacement	5J23
14-71.	Air Filter	5J23
14-72.	Control Valves	5J23
14-73.	Timer or Time Module	5K2
14-74.	Shuttle Valve	5K2
14-75.	Replacement	5K2
14-76.	Inspection (Preflight)	5K2
14-77.	Inspection (Post Flight)	5K2
14-78.	Inspection (100 Hours)	5K2
14-79.	Inspection (500 Hours and Pressure Test)	5K3
14-80.	Pressure Control Valves Adjustments	5K6
14-81.	High Pressure Deicer Boots	5K6

Paragraph		Aerofiche Grid No.
14-82.	Description	5K6
14-83.	Removal	5K7
14-84.	Pre-Installation Requirements	5K7
14-85.	Materials	5K7
14-86.	Preparation of Leading Edges	5K8
14-87.	Preparation of Deicer	5K8
14-88.	Installation of Deicer	5K8
14-89.	Service Life of Deicers	5K9
14-90.	Maintenance	5K9
14-91.	Icex Application	5K9
14-92.	Repair	5K10
14-93.	Cold Repair	5K10
14-94.	Deleted	
14-95.	Deleted	
14-96.	Scuff Damage	5K12
14-97.	Tube Area Damage	5K12
14-98.	Loose Surface Ply in Dead Area (Non-Inflatable Area) ...	5K13
14-99.	Loose Surface Ply in Tube Area	5K13
14-100.	Damage to Fabric Back Ply of High Pressure Deicer During Removal	5K14
14-101.	Vulcanized Repair	5K14
14-102.	Propeller Synchronizer (Hushtrol System)	5K19
14-103.	Description of Propeller Synchronizer System	5K19
14-104.	Troubleshooting	5K19
14-105.	Functional Test	5K19
14-106.	Maintenance	5K21
14-107.	Removal of Phase Servo	5K21
14-108.	Installation of Phase Servo	5K21
14-109.	Adjustment of Phase Servo	5K21
14-110.	Propeller Governor Adjustment	5K22
14-111.	Removal of Electronic Chassis	5K23
14-112.	Installation of Electronic Chassis	5K23
14-113.	Test Equipment	5K24
14-114.	Electric Windshield Anti-Ice	5K24
14-115.	Description	5K24
14-116.	Engine Synchrophaser	5L4
14-117.	Description of Synchrophaser System	5L4
14-118.	System Operating Procedure	5L4
14-119.	Operational Checks	5L5
14-120.	Troubleshooting	5L8
14-121.	Removal of Strobe Sensor	5L11
14-122.	Installation and Adjustment of Strobe Sensor	5L11
14-123.	Removal of Pulse Generator	5L13
14-124.	Installation and Adjustment of Pulse Generator	5L14
14-125.	Removal of Computer Assembly	5L15
14-126.	Installation of Computer Assembly	5L15
14-127.	Removal and Installation of Glow Lamp and Photo Conductor Assemblies	5L15

SECTION XIV

ACCESSORIES AND UTILITIES

14-1. INTRODUCTION. This section covers accessories which are available in this airplane and are not covered in other sections of this Service Manual. This information provides instructions for remedying difficulties which may arise in any of the accessories and the instructions are organized so the mechanic may refer to whichever component or system he must repair or adjust.

The Oxygen System contains service and maintenance procedures. Reference to this portion will aid the mechanic by providing information, such as the location of the various components, Inspection, Maintenance, Removal and Installation, Safety Precautions and other information of value, for the proper care of the system. A Troubleshooting Table at the end of the instructions will help to locate and remedy any troubles which may arise in the oxygen system.

The B. F. Goodrich Electrical Propeller De-Icing System information provides service and maintenance procedures for the De-Icers. This information consists of Inspection, Repair, Removal and Installation of all the parts which make-up the system. A Troubleshooting Table is incorporated at the end of these instructions to help in locating any trouble which may arise in this system and its probable cause and recommended remedy for repair. All work done on the De-Icing System must comply with the appropriate Civil Aeronautics Regulations.

The B. F. Goodrich Pneumatic System information provides Service, Maintenance and Repair procedures for the lightweight pneumatic de-icers installed on the wing and tail surfaces. For the various components that control the de-icers, there are check and adjustment procedures, as well as information for setting-up of the complete system. A Troubleshooting Table is also incorporated as an aid in remedying trouble which may arise.

14-2. OXYGEN SYSTEM.

14-3. DESCRIPTION AND PRINCIPLE OF OPERATION. The oxygen system for the PA-23-250 series airplanes consists of an oxygen cylinder and regulator, filler valve, pressure gauge, outlets and masks and an ON-OFF control. High pressure is routed from the cylinder and regulator to the pressure gauge. Low pressure oxygen is routed from the cylinder and regulator to the outlets and masks whenever the control knob is pulled to the ON position. Each outlet has a spring-loaded valve which prevents the flow of oxygen until a mask hose is engaged in the outlet.

14-4. TROUBLESHOOTING. A troubleshooting table, Table XIV-I, is located at the back of the oxygen system portion of this section.

14-5. SAFETY PRECAUTIONS. Utmost care must be exercised in servicing, handling and inspection of the oxygen system. A fully charged oxygen cylinder contains enough pressure to cause serious injury to personnel and damage to equipment. Keep hands, tools and working area clean and post NO SMOKING signs. Keep all components of the system free from oil, grease, gasoline and all readily combustible material. Never allow electrical equipment to come in contact with the oxygen cylinder. Keep fire and heat away from oxygen equipment and take care not to generate sparks with carelessly handled tools.

14-6. INSPECTION AND OVERHAUL TIME LIMITS. It is recommended that inspection and overhaul be conducted by a DOT Approved Station or the manufacturer, Scott Aviation. The following checks and chart gives recommended inspection and overhaul time for the various parts of the oxygen system:

a. Standard weight cylinders (DOT 3AA 1800 classification) must be hydrostatic tested every 5 years. The lightweight cylinders (DOT 3HT 1850 classification) must be hydrostatic tested every 3 years and must be retired from service after 15 years or 4,380 pressurizations whichever occurs first. The month and year of the last test is stamped on the cylinder beneath the DOT identification.

b. The outlets should be checked for leakage both in the non-use condition and for leakage around an inserted connector.

c. The high pressure gauge may be checked for accuracy by comparing its indicated pressure with that of a gauge of known accuracy.

d. Inspection of the regulator may be effected by introducing into an outlet a mask connector to which is attached a 100 psi gauge. With one other outlet flowing through a plugged in mask, the indicated regulator output pressure shall be not less than 45 psig at sea level with 200 psig supply cylinder pressure. It should be noted that the permissible leakage through the 1/16 diameter vent hole in the side of the upper regulator housing is 10 cc/min. maximum, when the regulator is turned on. There shall be no external leakage anywhere on the regulator when it is turned off. All fittings shall be leak free.

PIPER AZTEC SERVICE MANUAL

PARTS	INSPECTION	OVERHAUL
Regulator	300 Flight Hrs.	5 Yrs.
Pressure Gauge	300 Flight Hrs.	5 Yrs.
High Pressure Lines	300 Flight Hrs.	
Low Pressure Lines	300 Flight Hrs.	
Outlets (Cabin)	300 Flight Hrs.	5 Yrs.
External Recharge Valve	Each Use	Replace every 5 yrs.
Masks	Each Use	Replace as Necessary

14-7. TESTING FOR LEAKS. Apply detector fluid type CD-1 solution or its equivalent. The solution should be shaken to obtain suds or foam. The suds or foam should be applied sparingly to the joints of a closed system. Look for traces of bubbles. No visible leakage should be found. Repair or replace any defective parts and retest system. With the system pressurized to service pressure, further test can be made. The rate of any leak should not exceed one percent of the total supply per 24 hour period. All traces of the detector fluid should be wiped off at the conclusion of the examination.

14-8. MAINTENANCE.

- a. Make sure to check the oxygen lines for proper clearance as follows: (Refer to Figure 14-1.)
 1. Two inch minimum between oxygen tubes and all flexible moving parts of the aircraft (flexible control cables, etc.). If enough space cannot be attained, protection from abrasion must be provided.
 2. At least 1/2 inch minimum between oxygen tubes and all rigid moving parts of the aircraft such as levers and rigid control rods.
 3. Six inch minimum separation between oxygen tubes and hydraulic, fuel, and electrical system lines and components.
 - (A.) When six inch requirement cannot be complied with, one inch is allowed as long as electrical cables and other lines are supported at least every two inches; and, the oxygen tube(s) is protected by rubber neoprene hose fastened in place with cable ties at the location the specific item crosses or is near the oxygen tube(s). If an item is near the oxygen tube for a certain distance the oxygen tube for that distance must be covered.
 4. A minimum of 1/8 inch between tubing and structure adjoining the supporting clamp, as shown in Figure 14-1, Sketch A.
 5. Where a tube passes through a grommet, the tube must not bear on the grommet in any way that might cause cutting of the grommet in service as shown in Figure 14-1, Sketch D.
 6. While in service, items may receive vibrations causing them to come in contact with other parts of the aircraft. With this in mind, low pressure tubing that is supported well enough to prevent relative motion must have at least a minimum clearance of 1/8 inch from a projection (bolt, nut, etc.). Low pressure tubing that cannot be supported well enough to prevent motion must have a minimum clearance of 1/8 inch allowed after the maximum travel of the tube. High pressure lines are affected similarly but require 1/2 inch minimum clearances. Refer to Figure 14-1, Sketch B.
- b. Check the cylinder for DOT identification number and for the date of the last FAA inspection and test.
- c. If cylinder is completely empty it must be completely disassembled and inspected in an FAA approved facility before recharging.
- d. Any lines that are defective should be replaced with factory replacements.
- e. Clean all lines and fittings as described in paragraph 14-9.
- f. Use Ribbon Dope Thread Sealant (Permacel 412) on male ends of fittings only. Wrap thread in direction of thread spiral, beginning with the second thread on the fitting. Avoid getting any sealant into the lines.

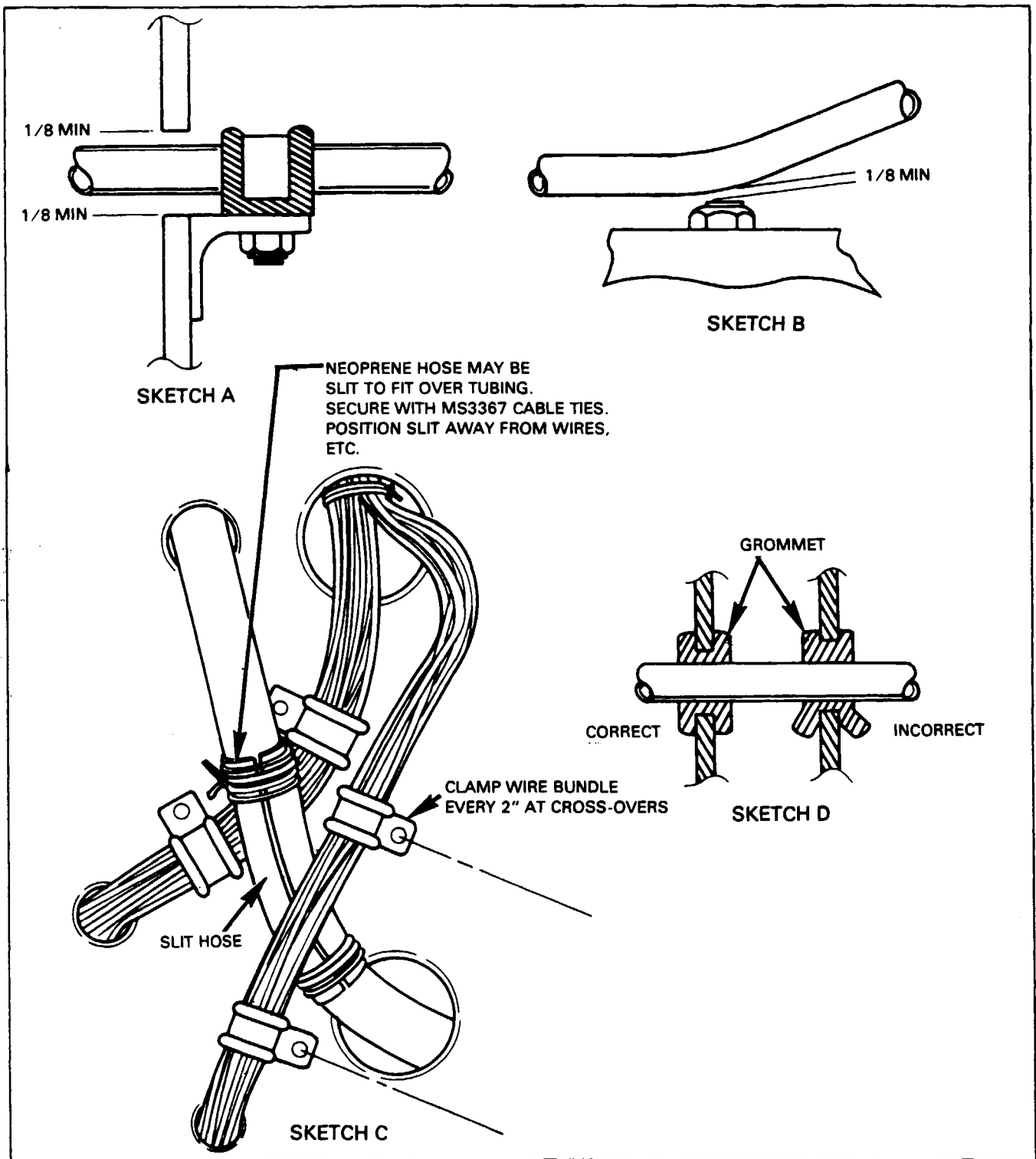
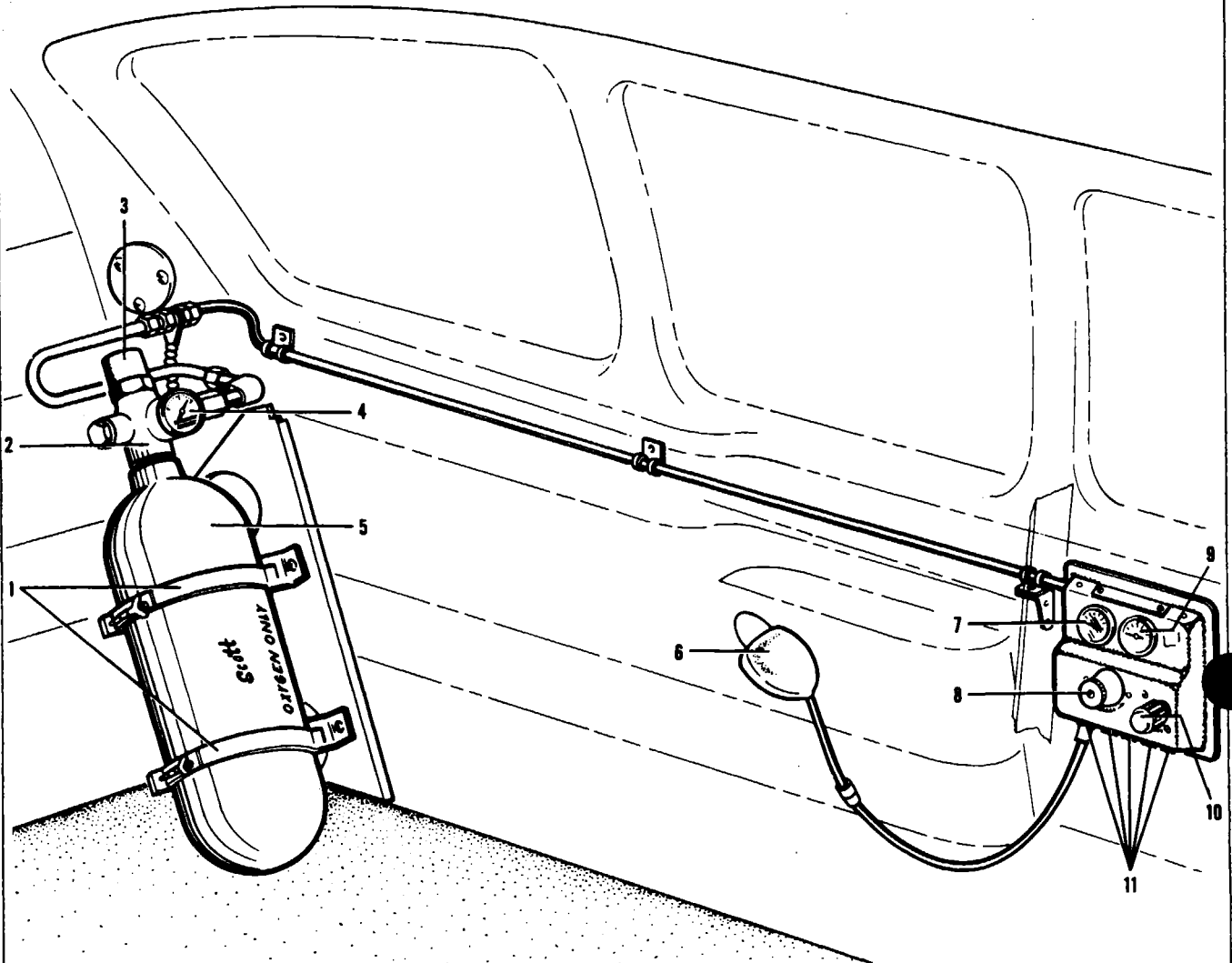

Figure 14-1. Oxygen Tubing Installations

2530



- 1. MOUNTING STRAPS
- 2. REGULATOR
- 3. ON/OFF CONTROL
- 4. PRESSURE GAUGE
- 5. CYLINDER
- 6. MASK AND LINE ASSEMBLY
- 7. ALTITUDE/FLOW RATE GAUGE
- 8. FLOW RATE CONTROL
- 9. PRESSURE GAUGE
- 10. ON/OFF CONTROL
- 11. OXYGEN OUTLETS

30050-A

Figure 14-2. Oxygen System Installation, PA-23-250

2833

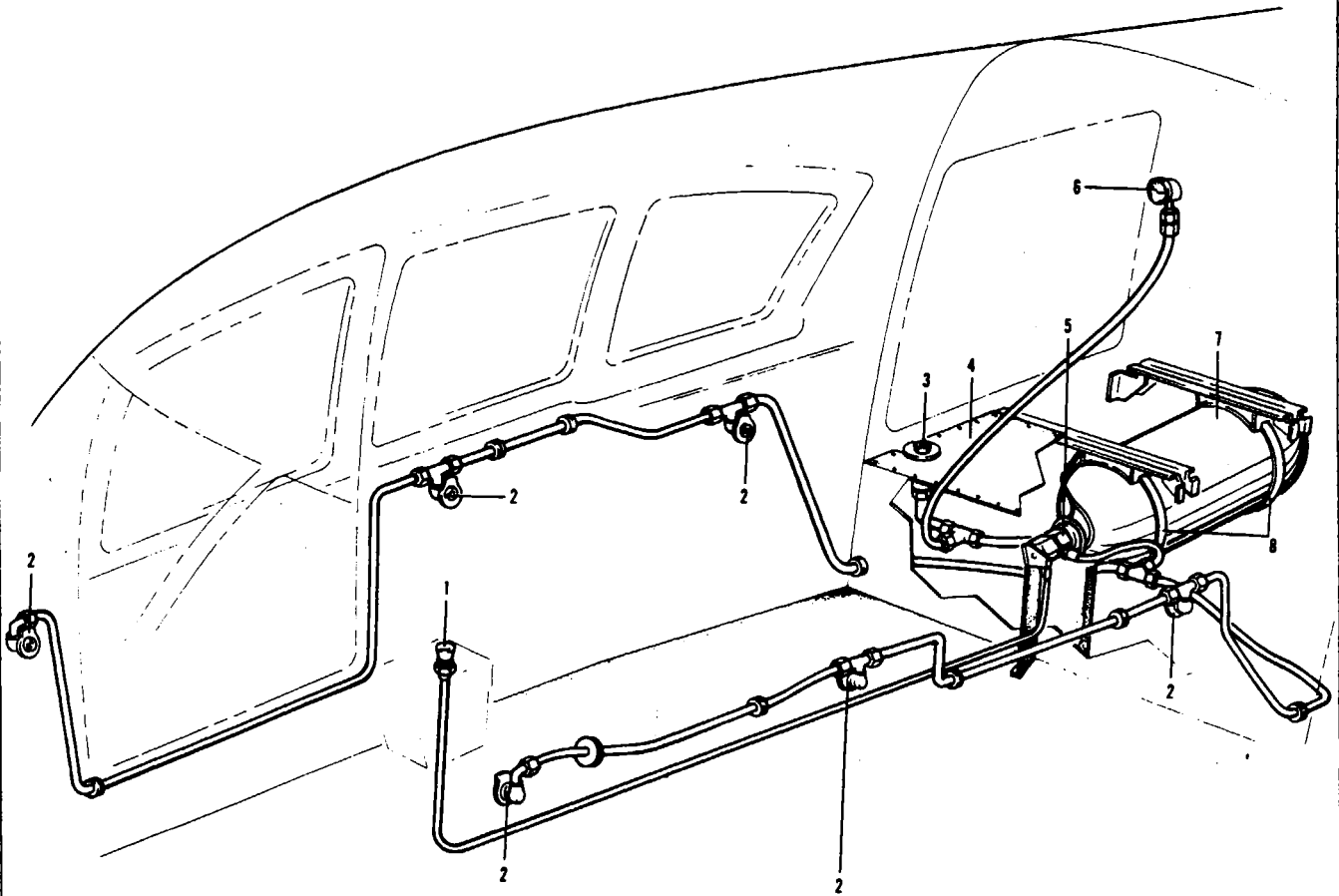

- 1. ON/OFF CONTROL
- 2. OXYGEN OUTLETS
- 3. RECHARGE VALVE
- 4. FORWARD BAGGAGE COMPARTMENT FLOORBOARD
- 5. REGULATOR
- 6. PRESSURE GAUGE
- 7. CYLINDER
- 8. MOUNTING STRAPS

31980-D

Figure 14-3. Oxygen System Installation, PA-23-250; PA-23-250 (six place), Serial Nos. 27-2000 to 27-3049 incl. and 27-3051 to 27-3153 incl.

2632

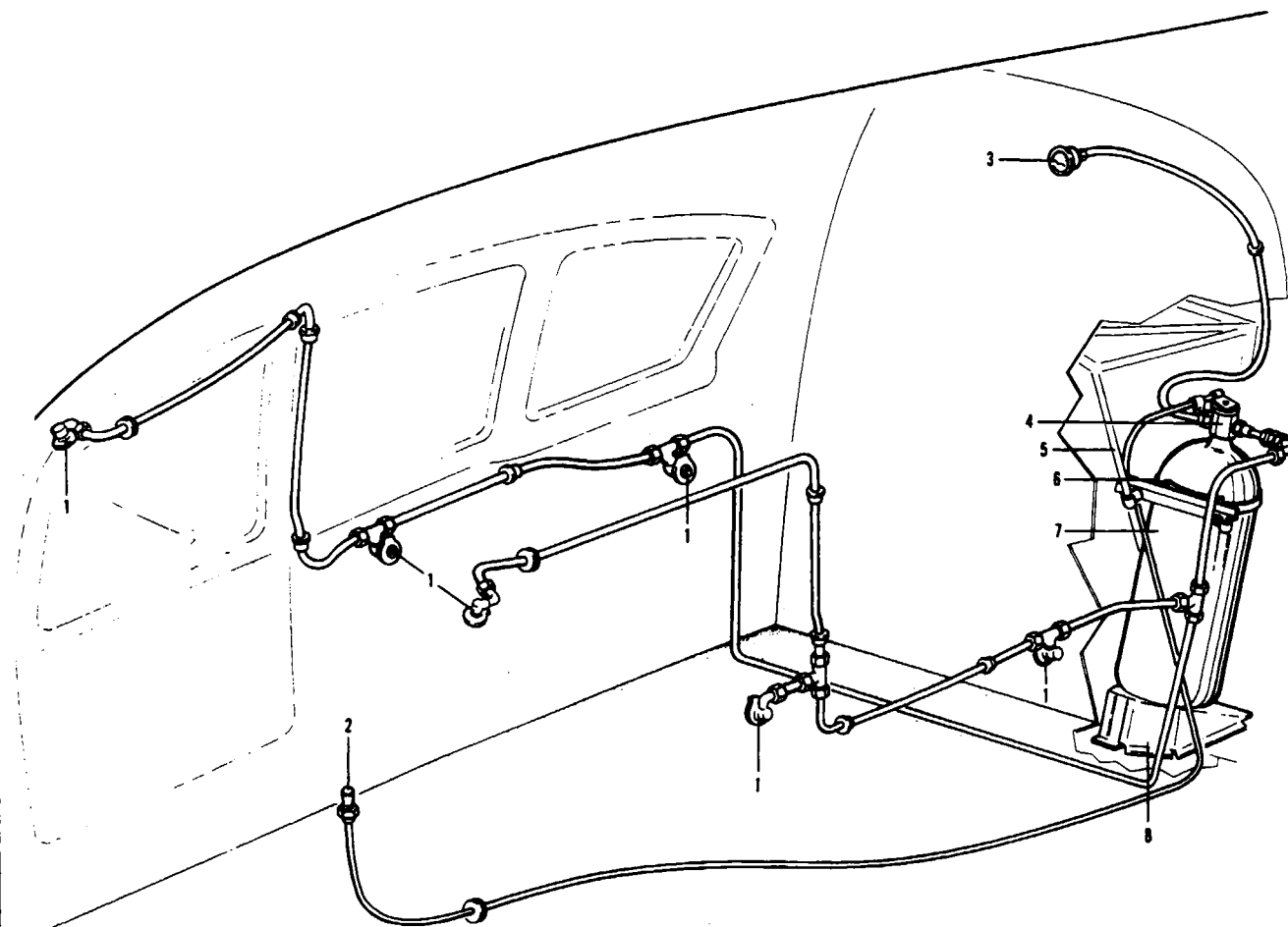

- 1. OXYGEN OUTLETS
- 2. ON/OFF CONTROL
- 3. PRESSURE GAUGE
- 4. REGULATOR
- 5. FUSELAGE FRAME
- 6. MOUNTING STRAP
- 7. CYLINDER
- 8. BASE

32140-1

Figure 14-4. Oxygen System Installation. PA-23-250 (six place),
Serial Nos. 27-3050, 27-3154 to 27-3836 incl. and 27-3838 to 27-3943 incl.

2631

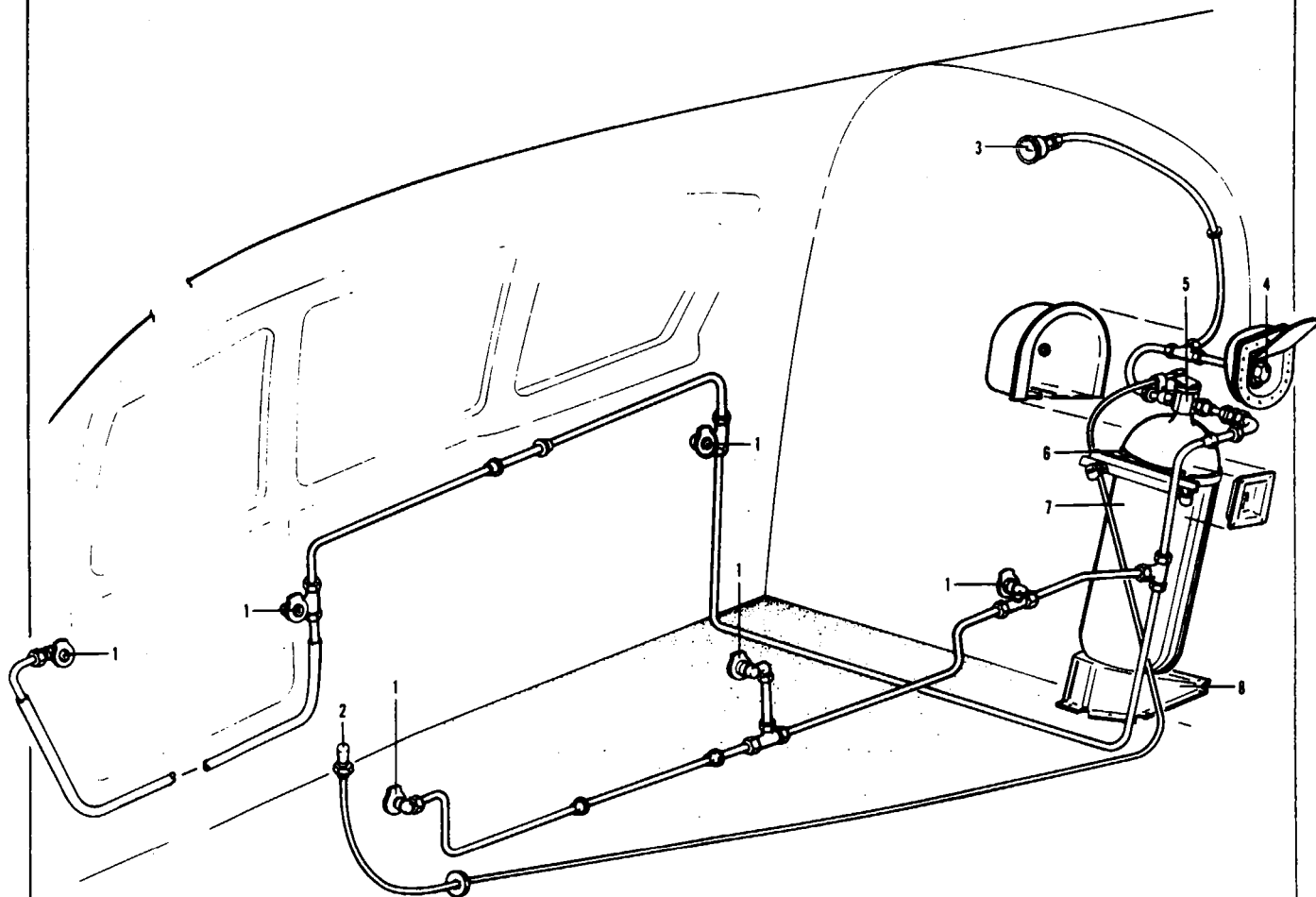

- 1. OXYGEN OUTLETS
- 2. ON OFF CONTROL
- 3. PRESSURE GAUGE
- 4. EXTERNAL RECHARGE VALVE
- 5. REGULATOR
- 6. MOUNTING STRAP
- 7. CYLINDER
- 8. BASE

32388-H

Figure 14-5. Oxygen System Installation, PA-23-250 (six place).
Serial Nos. 27-3837, 27-3944 and up

14-9. CLEANING OPERATIONS. To remove oil and grease from tubing and fittings, one of the following cleaning methods may be used:

a. First Method:

1. A vapor degreasing with stabilized trichlorethylene conforming to specification MIL-T-7003 shall be used.

2. Blow tubing clean and dry with a stream of clean, dried, filtered air. Care shall be taken to insure that the interior of the tubing and fittings are thoroughly cleaned.

b. Second Method:

1. Flush with naphtha conforming to specifications TT-N-95.

2. Blow clean and dry off all solvent with water pumped air.

3. Flush with anti-icing fluid conforming to specifications MIL-F-566 or anhydrous ethyl alcohol.

4. Rinse thoroughly with fresh water.

5. Dry thoroughly with a stream of clean, dried, water pumped air or by heating at a temperature of 250° to 300° F for a suitable period.

6. The solvents may be reused provided they do not become excessively contaminated with oil. This condition shall be determined as follows:

(a) Evaporate 100 milliliters of the liquid to dryness in a weighed glass dish. Evaporation may be accomplished by heating at 200° F for one-half hour.

(b) After evaporation, cool and weigh the residue. The solvent shall not be used if the residue exceeds 100 milligrams in weight.

c. Third Method:

1. Flush with hot inhibited alkaline cleaner until free from oil and grease.

2. Rinse thoroughly with fresh water.

3. Dry thoroughly with a stream of clean, dried, water pumped air or by heating at a temperature of 250° to 300° F for a suitable period.

14-10. REMOVAL OF OXYGEN CYLINDER AND REGULATOR.

WARNING

Do not attempt to remove the regulator from a charged cylinder.

CAUTION

Be sure the regulator valve is closed before disconnecting any oxygen lines from the cylinder.

a. The oxygen cylinder and regulator, located in the aft cabin section of PA-23-250 airplanes, may be removed as follows:

1. Disconnect the oxygen lines from the regulator.
2. Cut the safety wire loosen and separate the clamps holding the cylinder in place.
3. Remove the cylinder from the airplane. Use caution not to bump the neck of the cylinder and

regulator.

b. The oxygen cylinder and regulator, located under the floor of the aft baggage compartment of PA-23-250 (six place) airplanes in Serial Nos. 27-2000 to 27-3049 incl. and 27-3051 to 27-3153 incl., may be removed as follows:

1. Fold the carpet back from the forward part of the aft baggage compartment floor.
2. Remove the forward section of the baggage compartment floorboard by removing attaching screws.
3. Remove the aft baggage compartment trim panel by removing attaching screws.
4. Disconnect the oxygen lines and the ON-OFF control cable from the regulator.
5. Cut the safety wire, loosen and separate the clamps securing the oxygen bottle to the baggage compartment floor channels.

6. Remove the oxygen bottle and regulator through the rear of the aft baggage compartment.

c. The oxygen cylinder and regulator, located in the aft baggage compartment of the PA-23-250 (six place) airplane with Serial Nos. 27-3154 and up, may be removed as follows:

1. Disconnect the oxygen lines and the ON-OFF control cable from the regulator.
2. Cut the safety wire, loosen and separate the clamps holding the cylinder in place.
3. Remove the cylinder from the airplane. Use caution not to bump the neck of the cylinder and

regulator.

14-11. INSTALLATION OF OXYGEN CYLINDER AND REGULATOR.

a. On PA-23-250 airplanes, the oxygen cylinder and regulator may be installed in the following manner:

1. Position the cylinder and regulator inside the aft section of the cabin.
2. Connect the clamps securing the bottle in place. Safety the wing nuts.
3. Connect the oxygen lines to the regulator.

b. On PA-23-250 (six place) airplane with Serial Nos. 27-2000 to 27-3049 inclusive and 27-3051 to 27-3153 inclusive, the oxygen cylinder and regulator may be installed in the following procedure:

1. Position the oxygen bottle and regulator under the aft baggage compartment floor.
2. Secure the bottle and safety the clamps.
3. Connect the oxygen lines and ON-OFF control cable to the regulator.
4. Install the forward section of the baggage compartment floor and the aft trim panel with attaching screws.
5. Re-position the baggage compartment floor carpet.

c. On PA-23-250 (six place) airplanes with Serial Nos. 27-3154 and up, the oxygen cylinder and regulator may be installed in the following manner:

1. Position the cylinder and regulator inside the aft baggage compartment.
2. Connect the clamps securing the bottle in place. Safety the wing nuts.
3. Connect the oxygen lines and the control cable to the cylinder.

NOTE

Refer to Section II for filling instructions.

14-12. REMOVAL OF OXYGEN CYLINDER RECHARGE VALVE.

CAUTION

Before attempting to remove the recharge valve, ascertain the oxygen bottle is discharged or the regulator valve is off.

a. The recharge valve on PA-23-250 (six place) airplanes with Serial Nos. 27-2000 to 27-3049 inclusive; 27-3051; 27-3153 and up may be removed by the following procedure:

1. Remove the screws around the base of the recharge valve.
2. Pull the carpet back from around the forward edge of the baggage compartment floor.
3. Remove the screws around the front section of the baggage compartment floor and around the recharge valve. Remove the floor panel.
4. Remove the recharge valve by disconnecting the line fitting just below the valve. Cover the open line to prevent contamination.

b. Remove the recharge valve as follows on PA-23-250 (six place), Serial Nos. 27-3050, 27-3154 and up which incorporate an external valve along the left side of the fuselage.

1. Remove the cover from the top of the oxygen cylinder by removing attaching screws.

2. Disconnect the line fitting to the recharge valve. Cover the open line to prevent contamination.
3. Remove the valve by removing the screws securing it to the side of the fuselage.

14-13. INSTALLATION OF OXYGEN CYLINDER RECHARGE VALVE.

- a. The recharge valve on PA-23-250 (six place) airplanes with Serial Nos. 27-2000 to 27-3049 inclusive; 27-3051; 27-3153 and up may be installed by the following procedure:
 1. Position the valve and tighten the line fitting.
 2. Install the forward section of the baggage compartment floor panel and secure with attaching screws.
 3. Re-position the carpet and install the screws around the base of the recharge valve.
- b. Install the recharge valve as follows on PA-23-250 (six place) airplanes with Serial Nos. 27-3050, 27-3154 and up which incorporate an external valve along the left side of the fuselage.
 1. Position the valve from the outside of the fuselage and secure with attaching screws.
 2. Connect the recharge valve to the oxygen cylinder inside of the baggage compartment.
 3. Install the cover over the top of the cylinder and secure with attaching screws.

14-14. REMOVAL OF PRESSURE GAUGE. Ascertain that the control valve is closed and there is not pressure in the system.

- a. Disconnect the connector from the back of the pressure gauge.
- b. Loosen and remove the retainer nut and clamp holding the gauge in place.
- c. Pull the gauge out from the front of the panel.

14-15. INSTALLATION OF PRESSURE GAUGE.

- a. Place the gauge into the panel from the front and replace the clamp and retainer nut on the back of the gauge. Be sure the gauge is positioned properly before tightening the clamp.
- b. Reconnect the connector at the rear of the gauge.

14-16. REMOVAL OF OUTLETS.

- a. Using a suitable spanner wrench, remove the outer half of the outlet.
- b. Remove the screws holding the trim panel and remove the panel.
- c. The outlet can now be removed from the low pressure line.

14-17. INSTALLATION OF OUTLETS.

- a. Apply a sealant to the male end of the fitting.
- b. Connect the outlet to the low pressure line.
- c. Position the trim panel and secure with screws.
- d. Position the outer half outlet and secure with a suitable spanner wrench.
- e. Torque the fittings into the outlets approximately 30 inch-pounds. Do not over torque as this could damage the outlet.

14-18. PURGING OXYGEN SYSTEM. The system should be purged whenever the cylinder pressure fails below 50 psi or if any lines are left open for any length of time. Also, whenever there are any offensive odors present it will be necessary to purge the system. Use the following procedure:

- a. Park the airplane in a NO SMOKING area.
- b. Keep all doors and windows open.
- c. Be sure all electrical systems are shut off.
- d. Connect the oxygen recharging unit to the filler valve.
- e. Plug the oxygen masks into the outlet valves and turn on the system.
- f. Set the recharging unit pressure regulator to deliver 50 psi and let the system purge for one hour. If any odor is still present, repeat the procedure for one or more hours. If the odor persists after the second purging, replace the cylinder.

14-19. CLEANING OF FACE MASKS. The disposable masks are designed for one-time use and require no maintenance. The pilots and co-pilots masks can be cleaned as follows:

- a. Remove the microphone from the mask.
- b. Remove the sponge rubber discs from the mask turrents. Do not use soap to clean sponge rubber discs, as this would deteriorate the rubber and give off unpleasant odors. Clean in clear water and squeeze dry.
- c. Wash the rest of the mask with a very mild solution of soap and water.
- d. Rinse the mask thoroughly to remove all traces of soap.
- e. Make sure the slides of the breathing bag do not stick together while drying, as this may decrease the life of the rubber in the bag. The mask can be sterilized with a solution of 70 percent ethyl alcohol.

14-20. PROPELLER DE-ICER SYSTEM.

14-21. DESCRIPTION AND PRINCIPLES OF OPERATION. (Refer to Figure 14-6 or 14-7.) This section provides service and maintenance procedures for the B. F. Goodrich Electrical Propeller De-Icing System. Each Propeller De-Icing System consists of an electrically-heated De-Icer (9) bonded to each propeller blade, a slip ring assembly (8) with a brush block assembly (7) to transfer electrical power to the rotating De-Icers, a timer (1), an ammeter (5), and a control switch (3) together with wiring harnesses to complete the circuit.

To conserve electrical power, current is cycled to the De-Icer heaters at timed intervals rather than continuously. Each De-Icer has two separate heaters, one for the outer half and one for the inner half. By heating all outer or inner heaters on only one propeller at a time, rotational balance is held during de-icing. Current is drawn from the airplane electrical system through the switch, ammeter and timer. The timer successively delivers current via the slip ring and brush block arrangement to the outer heaters on the right propeller, the inner heaters on the same propeller, the outer heaters on the left propeller and the inner heaters on the left propeller. The timer energizes each of these four phases in turn for about 30 seconds and then repeats the cycle as long as the control switch is on. The cycling sequence given is vital so that outboard heaters on each propeller operate before the inboard heaters. Refer to Figures 14-8 through 14-11 which represent a typical, not a particular, system. Correct circuit diagrams for each system are shown in Figures 14-18 and 14-19. The use of heat at the ice adhesion surface reduces the grip of the ice which is then removed by the centrifugal effect of rotation and the blast of the airstream. Note that a minimum thickness or weight of ice must build-up before centrifugal force becomes important. The system may be used continuously in flight if needed.

NOTE

Heating may begin at any phase in the cycle depending on the timer position when the switch was turned off from previous use.

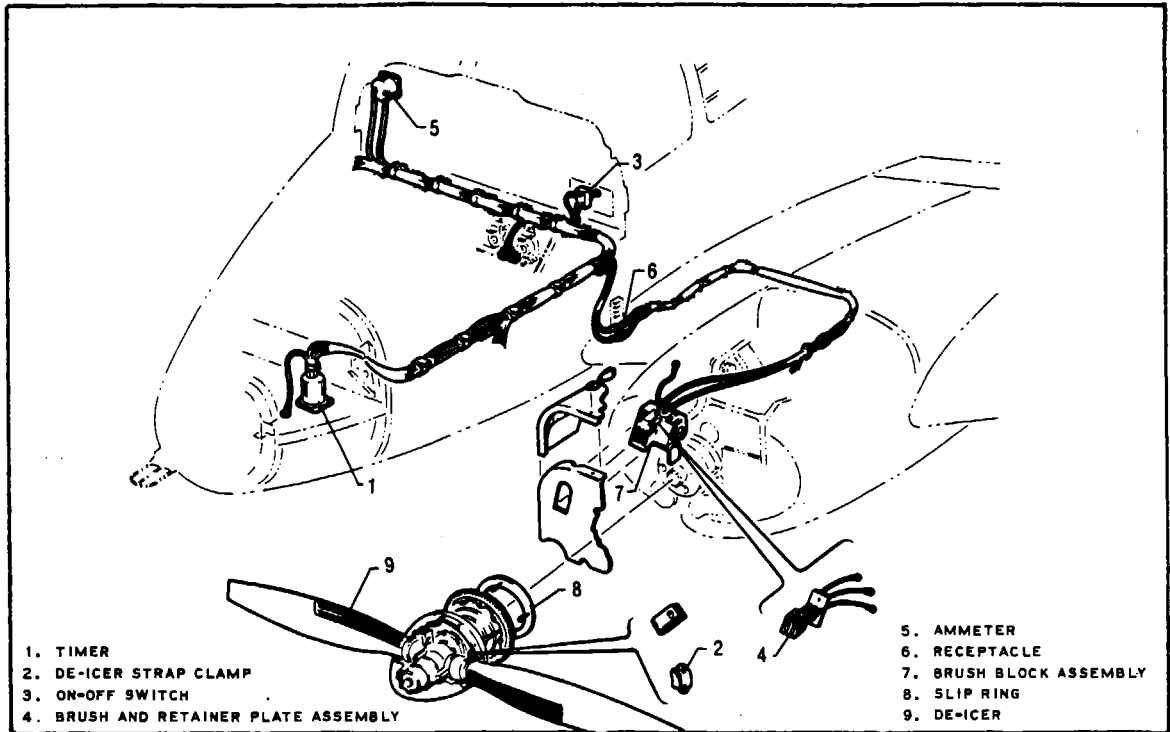

Figure 14-6. Propeller De-Icer Installation, PA-23-250

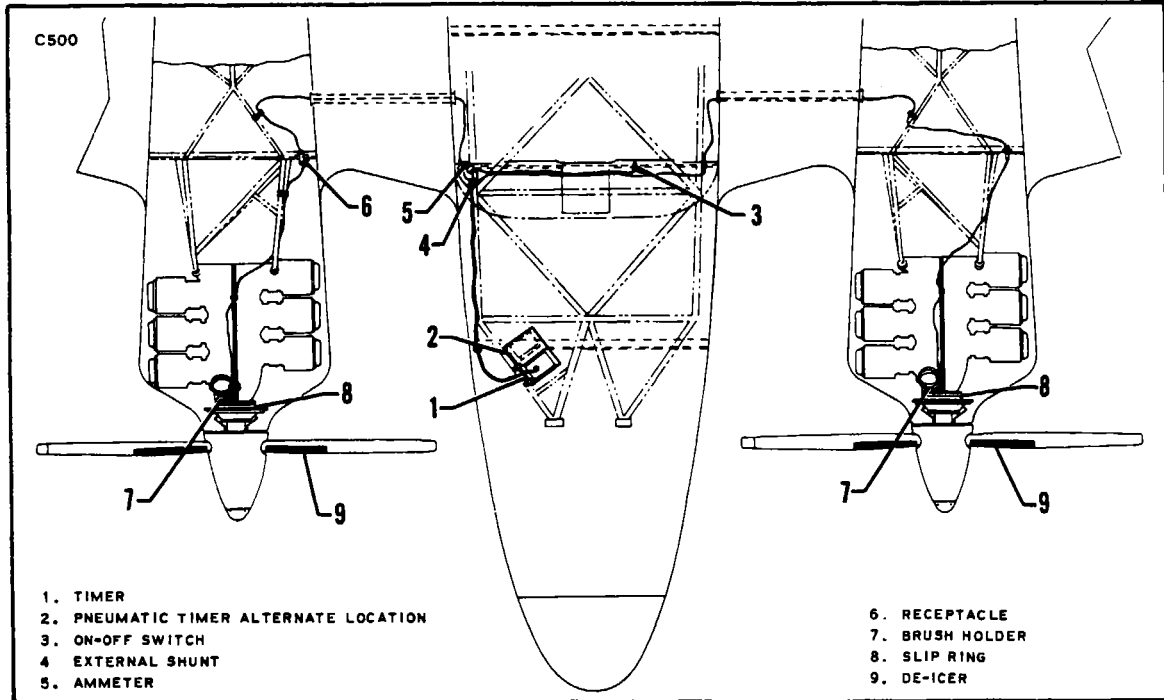

Figure 14-7. Propeller De-Icer Installation, PA-23-250 (six place)

a. De-Icers: The De-Icers contain special heater wires protected by fabric plies and by oil and abrasion-resistant rubber. The side of the De-Icer cemented to the prop has a dull finish whereas the air side finish is "glossy". B. F. Goodrich Report 59-728 covers installation of the De-Icers on the propellers; a copy of such report should be kept with this manual.

NOTE

Each De-Icer has a separate lead for the inboard and outboard heater and a third lead which is a common ground. These leads are so marked on all but a few early de-icers. An unmarked ground can be identified by using an ohmmeter across the three possible pairs of leads. Two pair will show identical resistance; the third pair will show double this resistance. The latter are the "hot" leads and the lead not in this pair is the ground lead.

NOTE

The wiring diagrams in Figures 14-18 and 14-19 show the brush, slip ring and De-Icer connections, which vary according to the system number at hand. Be sure to follow the wiring diagram for the specific system involved.

b. Slip Rings - Brushes and Brush Blocks: To transfer electrical power to the rotating De-Icers, a brush block assembly is mounted to the engine or similar stationary member and has brushes which are spring loaded to press against the revolving slip rings. The slip ring assembly is either mounted on the aft side of the spinner bulkhead or crankshaft flange or, alternately, is provided as a slip ring gear assembly which replaces the original starter ring gear of the engine.

c. Timer: The timer is a sealed unit. If found inoperative, it must be replaced as an assembly - no field repairs are authorized. The two types of timers used are interchangeable electrically. By drilling new mounting holes, timers of either type may be used as replacement for the other.

d. Ammeter: The ammeter is designed for each particular system and it is therefore important that the correct replacement part number be used if replacement should be required. In the event of low airplane battery voltage (very possible in ground checks), the ammeter readings will be lower than at full voltage. Provided the ammeter needle reads in the shaded range on the scale, current flow is to be considered as normal.

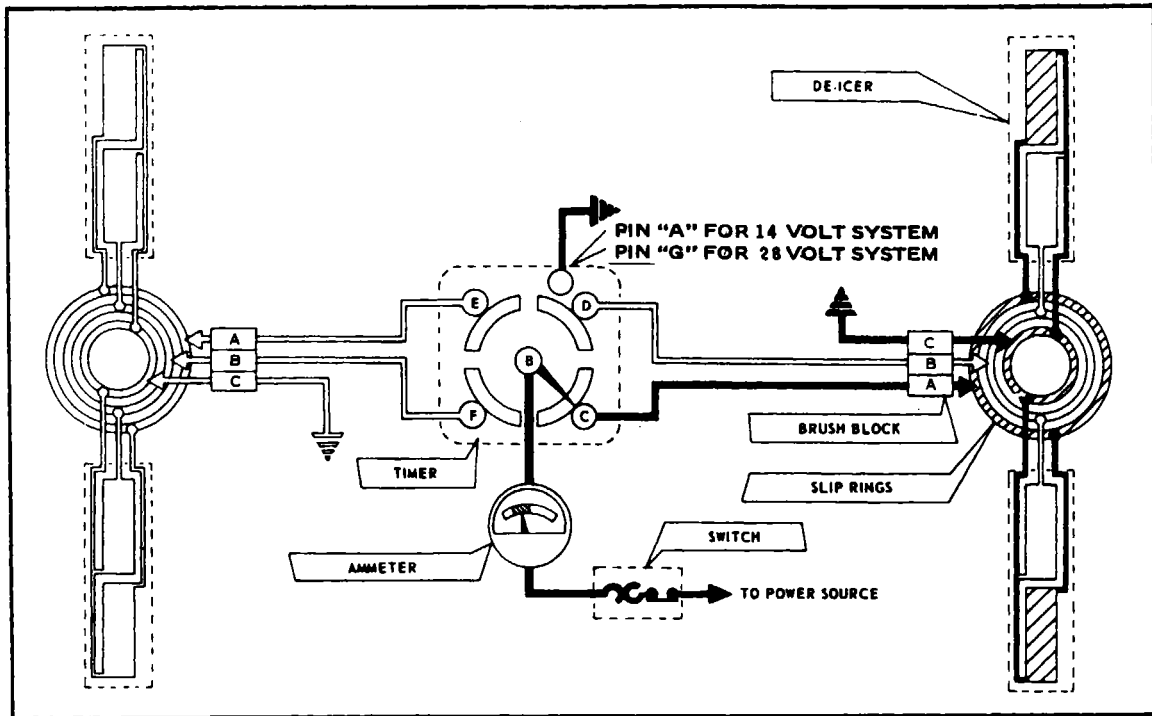

Figure 14-8. Electrical Diagram Showing Cycle Sequence, Phase 1

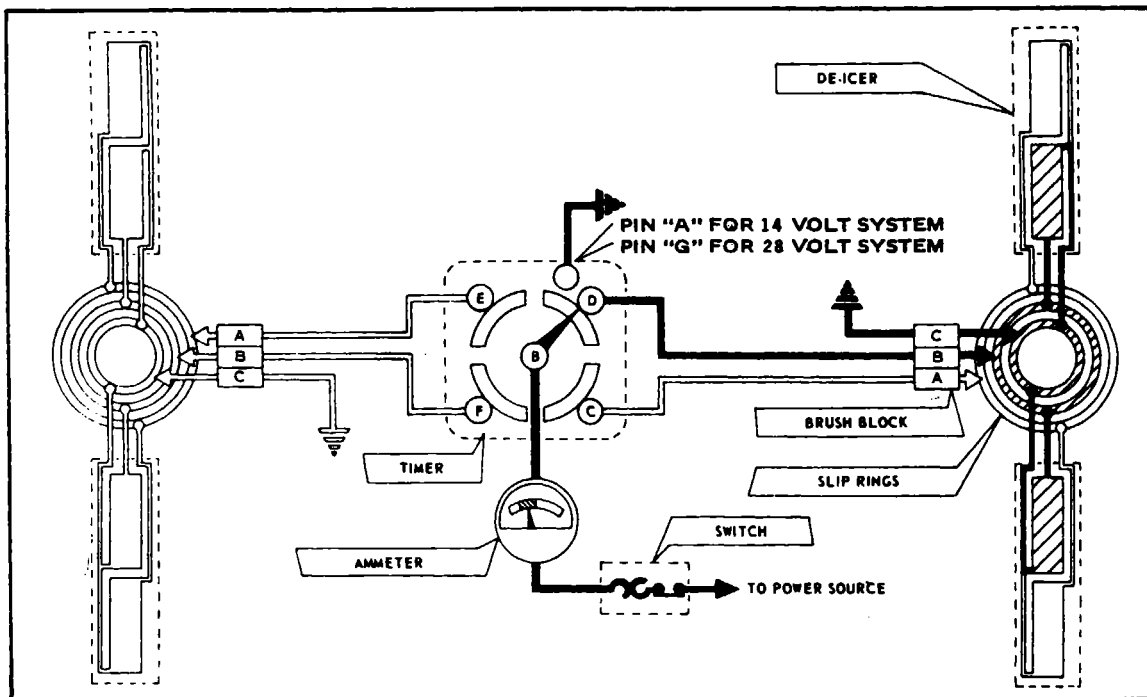

Figure 14-9. Electrical Diagram Showing Cycle Sequence, Phase 2

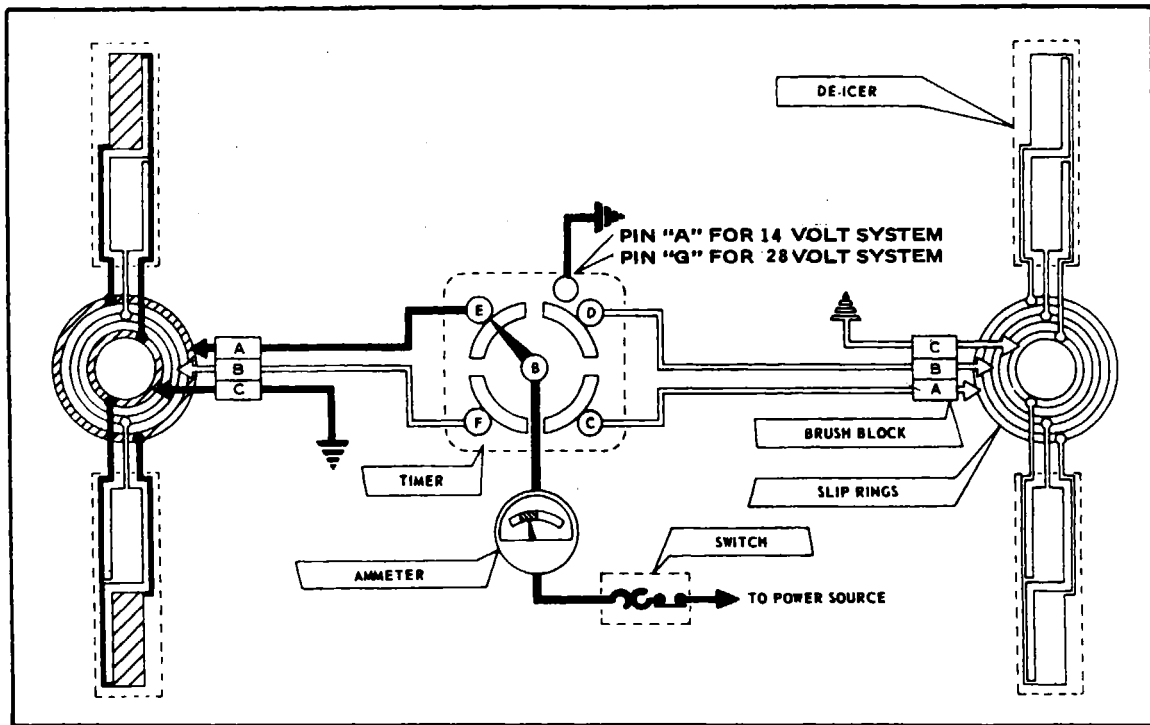

Figure 14-10. Electrical Diagram Showing Cycle Sequence, Phase 3

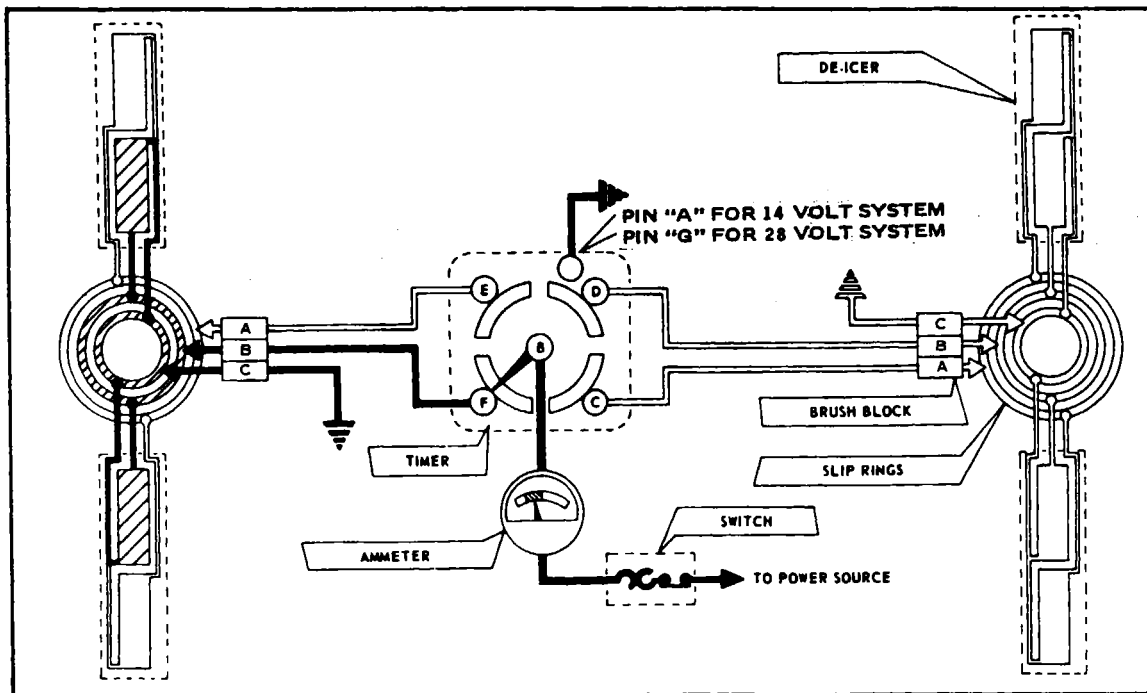

Figure 14-11. Electrical Diagram Showing Cycle Sequence, Phase 4

14-22. DE-ICER SYSTEM OPERATIONAL CHECK.

- a. Chock the wheels and operate the engine at near take-off power.
- b. Turn De-Icer system switch ON and observe De-Icer ammeter for at least two minutes.
- c. The ammeter needle must "flicker" approximately every 30 seconds as the step switch of the timer operates.
- d. With engines stopped, turn De-Icer switch ON and feel De-Icers on propellers for proper sequence of heater operation.
- e. The starting point is not important but the sequence is vital and must be: Right Outboard, Right Inboard, Left Outboard, Left Inboard heaters. in that order.
- f. Temperature rise should be noticeable and each heater should warm for about 30 seconds.
- g. Local hot spots indicate surface damage of De-Icer heaters and should be repaired.

14-23. INSPECTION.

14-24. FIFTY-HOUR INSPECTION.

- a. Lock brakes and operate engines at near take-off power. Turn De-Icer system switch ON and observe De-Icer ammeter for at least 2 minutes. Ammeter needle must reset within the shaded band except for a "flicker," each approximately 30 seconds, as the step switch of the timer operates. If not, refer to the appropriate entry of the troubleshooting table, Table XIV-III.

WARNING

Stand clear of propellers - be sure ignition switch is OFF.

- b. With engines stopped, turn De-Icer switch ON and feel De-Icers on propellers for proper sequence of heater operation. The starting point is not important but sequence is vital and must be: **RIGHT OUTBOARD, RIGHT INBOARD, LEFT OUTBOARD AND LEFT INBOARD** heaters, in that order. Temperature rise should be noticeable and each heater should warm for about 30 seconds. Local hot spots indicate service damage of De-Icer heaters - inspect and repair as in paragraph 14-32.

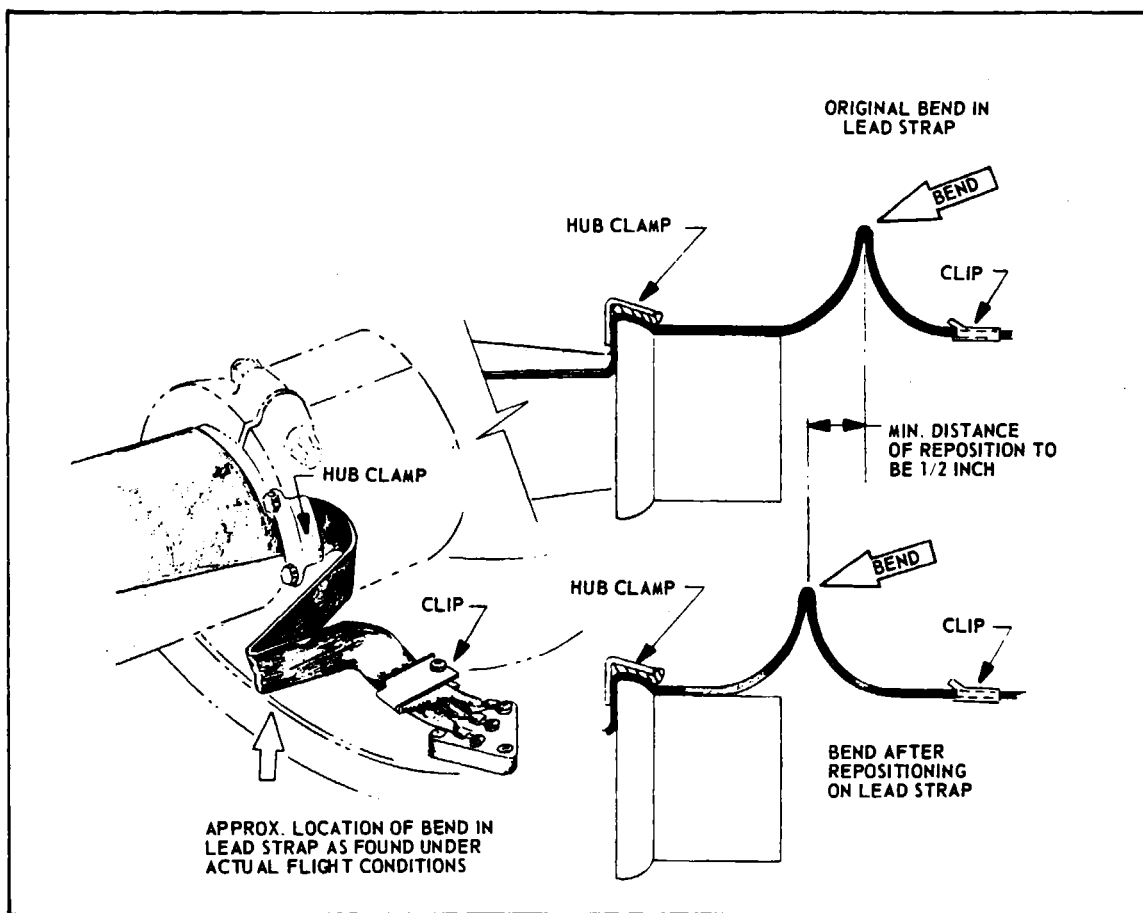

Figure 14-12. Relocating Bend in De-Icer Lead

c. Remove spinner dome and open access doors as required. With assistant observing De-Icer ammeter and with De-Icer switch ON, flex all accessible wiring - particularly the De-Icer lead straps, leads from slip ring assembly and the firewall electrical connectors and their wiring. Any movement of the ammeter needle - other than the "30 second flicker" of cycling - indicates a short or open that must be located and corrected. (Refer to paragraph 14-25, f.)

d. Relocate bend of lead strap between hub clamp and clip as in Figure 14-12. This periodic relocation increases the life of the straps.

e. Check for damaged brush rods, springs or for worn or damaged brushes. Refer to Figure 14-13 or 14-14 as applicable, to determine brush wear.

NOTE

Brush modules should be replaced when 3/8 inch of brush material remains; brush modules MUST be replaced when 1/4 inch remains. Measure as shown in Figure 14-14.

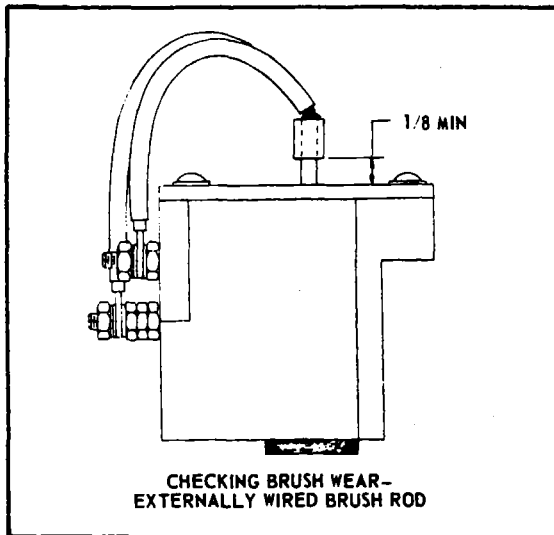

Figure 14-13. Determining Brush Wear

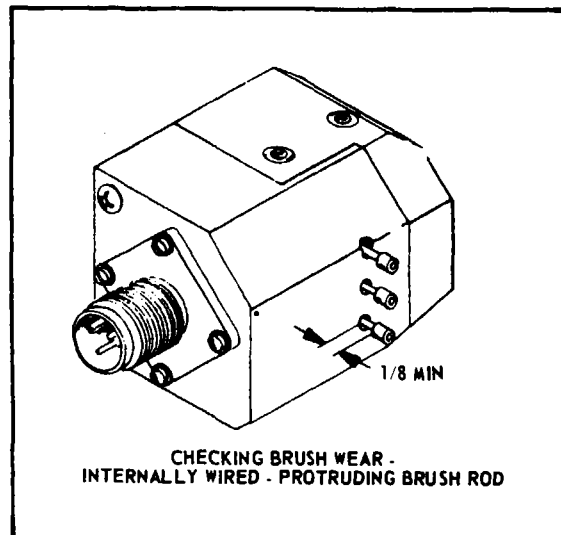

Figure 14-14. Determining Brush Wear

14-25. ONE-HUNDRED HOUR INSPECTION.

- a. Conduct 50-hour inspection.
- b. Check for radio noise or radio compass interference by operating engine at near take-off power and with radio gear ON while turning De-Icer switch ON and OFF. If noise or interference occurs with De-Icer switch ON and disappears when switch is OFF, see Troubleshooting.
- c. Visually and by feel check for clamps, clips, mountings, electrical connections and connectors for tightness and electrical soundness. Look for loose, broken or missing safety wire.
- d. De-Icers: Closely check De-Icers for wrinkled, loose or torn areas, particularly around the outboard end and where the strap passes under the hub clamp. Look for abrasion or cuts, especially along the leading edge and the flat or thrust face. If heater wires are exposed in damaged areas or if rubber is found to be tacky, swollen or deteriorated (as from oil or fluids solvent contact), replace the damaged De-Icer.

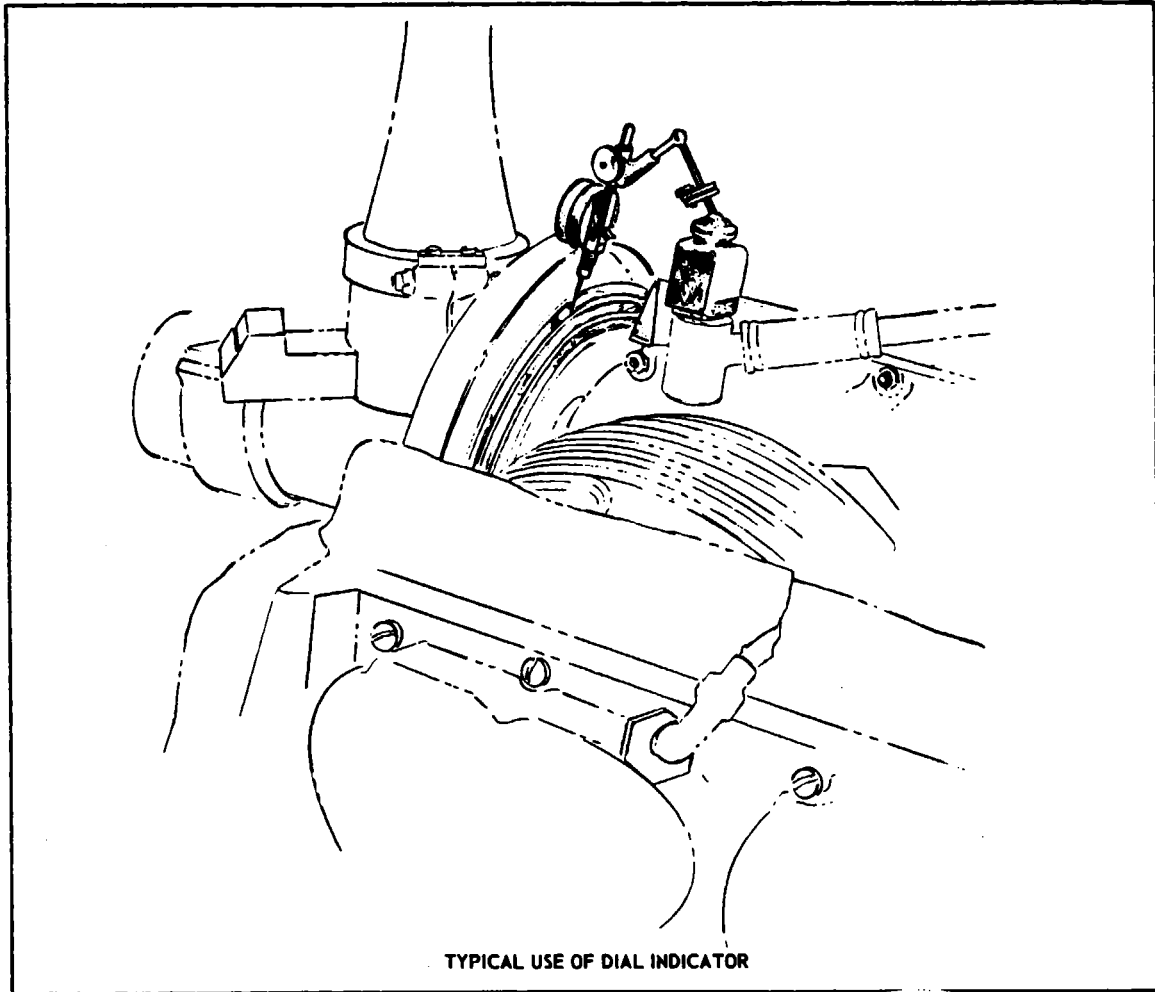

Figure 14-15. Checking Slip Ring Run-Out

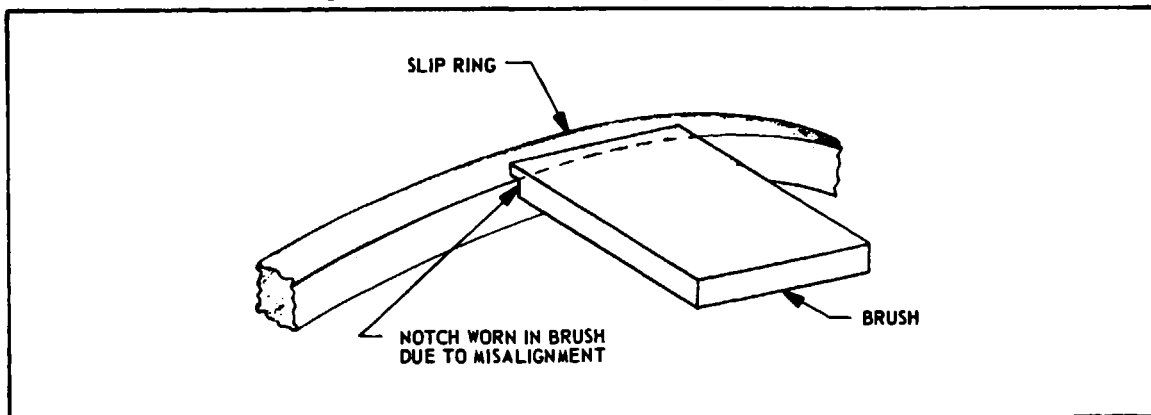

Figure 14-16. Wear Pattern of Misaligned Brush

NOTE

Check that hub clamps are tight. Look for cracks or other damage. See that cushioning material is not missing or damaged, either under hub clamp or on edge of spinner dome. Manually operate propeller from "full pitch" to "feathering" and check that De-Icer lead straps do not come under tension or are pinched by the propeller blade. (Refer to Figures 14-28 and 14-29.)

e. Slip Rings: Visually and by feel check slip rings for gouges, roughened surface, cracks, burned or discolored areas and for deposits of oil, grease or dirt.

1. Clean greasy or contaminated slip rings with CRC 2-26 solvent (from Corrosion Reaction Consultants, Inc. of Philadelphia, Pa.). In such case, a run-in time of 5 hours engine operation must be allowed before De-Icer system is turned on.

2. If uneven wear is found or if wobble is noticed, set up dial indicator as in Figure 14-15 to check alignment of slip rings on prop shaft. (Push in to turn prop to eliminate play in prop thrust bearing.) If runout over 360 degree rotation is over 0.005 inches total or exceeds 0.002 inches in any 4 inch arc, refer to paragraph 14-51.

f. Brush Block - Brushes: Examine mounting brackets and housings for cracks, deformation or other physical damage. See that leads are not chafed or binding. Check for tight connections.

1. Test that each brush rides fully on its slip ring over 360 degrees. Figure 14-16 shows wear pattern if this condition is not correct. If off alignment, shim under brush block or elongate holes at mounting brackets to raise or lower brush block to proper position. (If brushes ride both high and low in relation to slip rings in 360 degree rotation, the slip ring assembly is eccentrically mounted and the spinner bulkhead must be replaced as in paragraph 14-52.

2. Check for proper clearance of brush block to slip rings as in Figure 14-17. If not correct, loosen mounting screws and move in elongated holes to correct block position before tightening securely. (If necessary, shim between thrust bearing plate and mounting plate.)

3. By eye, check brush block to have about 2 degree angle of attack as in Figure 14-17. If not, loosen mounting bolts and twist block but be sure to hold clearance limits shown, when tightening.

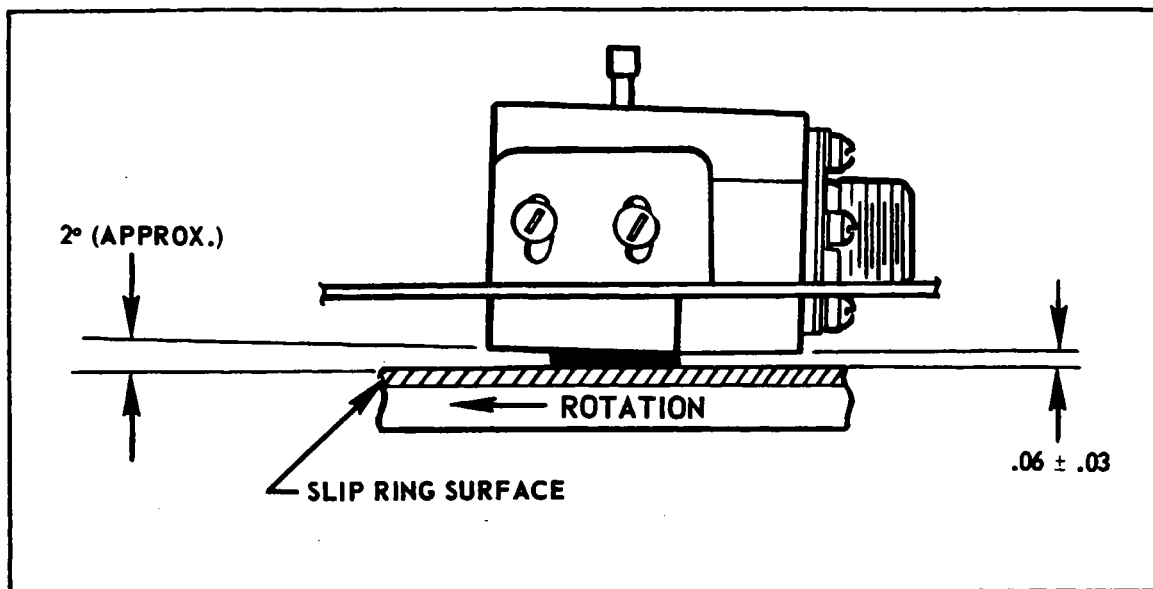

Figure 14-17. Brush Block Positioning

g. System Wiring: With De-Icer system operating, have assistant observe ammeter while visually inspecting and physically flexing wiring from brush blocks thru firewall, to timer, to ammeter, to switch and to airplane power supply. The ammeter will flicker as the timer switches each 30-seconds in the cycle. Jumps or flickers at other times indicate loose or broken wiring in the area under examination at that moment. In such case, check continuity thru affected harness, each wire in turn, while flexing and prodding area that gave initial indication of trouble. Use wiring diagram to trace circuitry.

14-26. TROUBLESHOOTING. (Refer to Table XIV-I.)

14-27. HELPFUL TIPS.

a. If the ammeter reading drops to one-half normal current, this indicates that one heater circuit is open from the slip ring assembly to the De-Icer heater or possibly improper connections allowing both inboard and outboard units to heat at the same time.

b. Excess current reading on the ammeter always indicates a power lead is shorted to ground. In such case, it is possible that the excess current may have welded the time contacts in one phase. The result may be a timer which does not cycle or, possibly, the timer may continue to cycle but also feeds the welded contacts continuously. The latter condition will, in the heat test, show as two phases heating simultaneously, over 3 of the 4 phases. Thus, when trouble of

this nature is found it is vital that the grounded power lead be located and corrected. Otherwise, a new timer may suffer the same internal damage during first use of the system.

c. A considerable number of timers have been returned for repair which proved, on test, to be fully workable. Before concluding that the timer is at fault, accomplish the test described in paragraph 14-28.

d. In cases where brush breakage or rapid brush wear is found to be a cause of trouble, be sure to check brush block alignment and adjustment as in paragraph 14-25, f. Also, check slip ring alignment per paragraph 14-51.

14-28. USING AMMETER. Whether in flight or during ground testing, the ammeter can be used to indicate the general nature of most electrical problems. The "Troubleshooting" chart is primarily based on this use of the ammeter and assumes that the user does understand all normal operating modes of the system as given in paragraph 14-21. Read all of the trouble entries to locate that which matches conditions of the particular system being checked. The causes and remedies in the same box then show the recommended sequence of check.

NOTE

When troubleshooting, first use the "ammeter test" and "heat test", paragraph 14-24, a and b, to determine which circuits are involved. Use circuit diagrams to check voltages or continuity.

14-29. TIMER TEST. Field experience indicates that too often the timer is considered at fault when the true trouble lies elsewhere. Before removing a timer as defective, perform this test:

a. Disconnect harness at timer and with De-Icer switch ON, check voltage from pin B of harness plug to ground. If system voltage is not present, the fault is not in the timer. If system voltage is present at pin B, check ground circuit using ohmmeter from either harness plug pin A (if 14-volt system) or pin G (if 28-volt system) to ground. If no circuit is shown, the fault is in ground lead, not in timer. If ground connection is open, the timer step switch will not change position.

b. When power and ground circuits have been checked, connect a jumper wire from pin B of harness to B contact of timer socket to power timer. Connect a jumper wire from either pin A (if 14-volt system) or pin G (if 28-volt system) of harness to A or G contact respectively of timer socket to complete the power circuit. Now use voltmeter from ground to the timer socket and check that timer

is cycling to deliver system voltage to C, D, E and F contacts in that order (the starting point is not important but sequence must be as given). Each of these four contacts must deliver voltage for approximately 30-seconds, in turn, and there must be zero voltage on the three contacts not energized.

c. If the timer meets these requirements, it is not the cause of trouble. If it fails to perform as indicated, the trouble does lie in the timer and it should be replaced.

14-30. DE-ICER RESISTANCE CHECK. To determine incorrect resistance, short or open at the brush-to-slip ring contact, disconnect harness at the timer and use low-range ohmmeter to read resistance from each De-Icer circuit lead (pins C, D, E and F of harness plug) to ground. If not in the range shown in the table following, disconnect the De-Icer lead straps to measure heater resistances individually as in the last line of the table. If first check is off limits but second check is OK, the trouble is probably in the brush-to-slip ring area; if the second check is off limits, the De-Icer concerned is damaged and must be replaced.

DE-ICER RESISTANCE CHART (Ohms)		
	No. 4E1188	No. 4E1214
IN PARALLEL (At harness) Two blades	2.30 to 2.65	0.60 to 0.69
INDIVIDUAL HEATER	4.58 to 5.26	1.15 to 1.33

14-31. BRUSH BLOCK RESISTANCE CHECK. To determine when open, short or high resistance is present in brush block, use low range ohmmeter to measure resistance from face of brush to its terminal studs or receptacle pin. If over 0.013 ohms, locate and repair cause of high resistance; if zero, locate and repair open or ground or else replace the brush. Check resistance between the three terminal studs or receptacle pins. This resistance should not be less than 0.5 megohms.

PIPER AZTEC SERVICE MANUAL

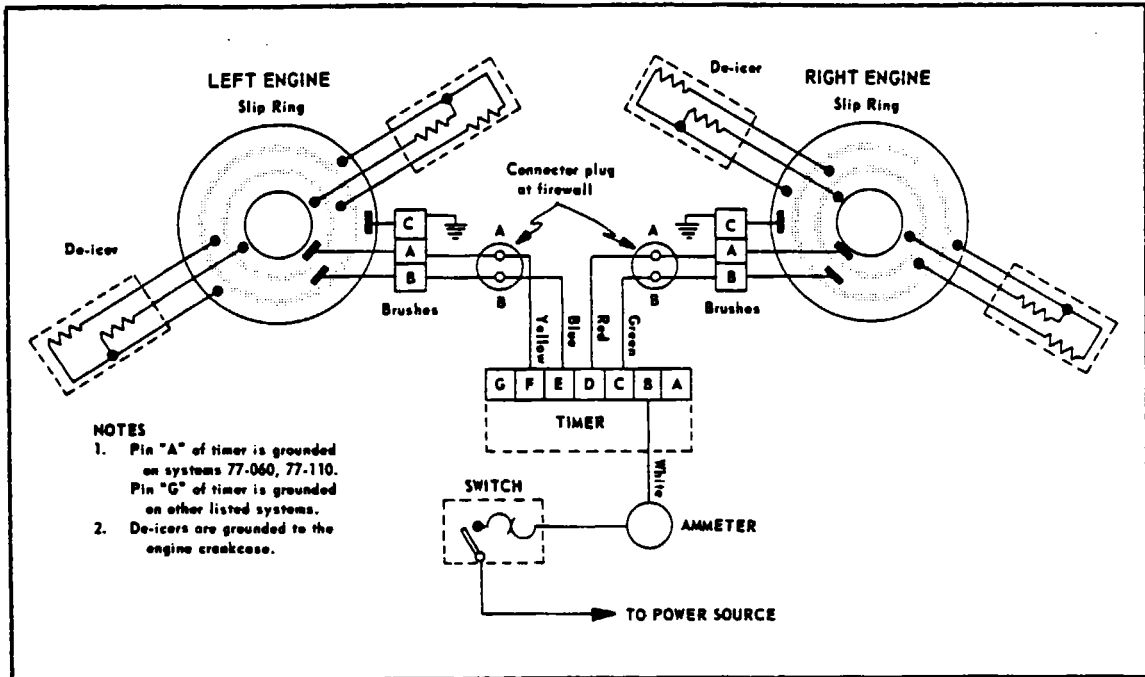

Figure 14-18. Schematic Wiring Diagram, PA-23-250; PA-23-235; and PA-23-250 (six place). Serial Nos. 27-2000 to 27-2504 incl.

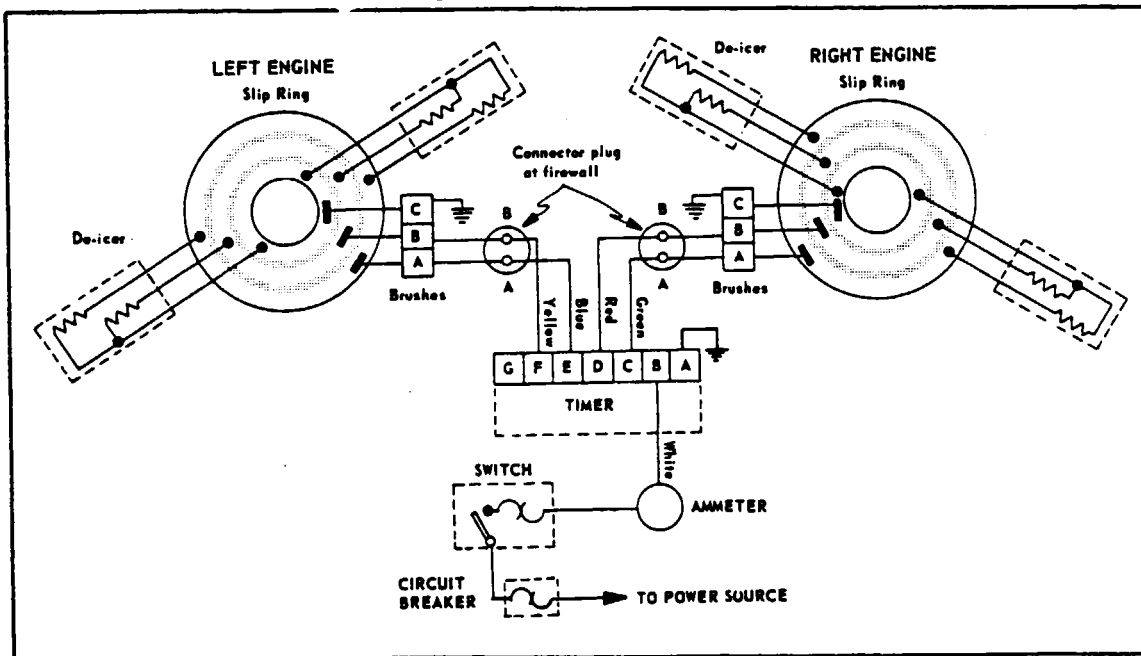

Figure 14-19. Schematic Wiring Diagram, PA-23-250 (six place). Serial Nos. 27-2505 and up

PIPER AZTEC SERVICE MANUAL

TABLE XIV-I. PROPELLER DE-ICER SYSTEM TROUBLESHOOTING

Trouble	Cause	Remedy
<p>Ammeter shows zero current. (All 4 phases of the 2 minute cycle.)</p>	<p>Blown fuse (if used).</p> <p>Switch faulty.</p> <p>No power from airplane.</p> <p>Ammeter faulty. (If some or all De-Icers heat with ammeter at zero, replace the ammeter.)</p> <p>Open ammeter to timer.</p>	<p>Locate and correct short before replacing the blown fuse.</p> <p>If no voltage at switch output with voltage at switch input, replace the switch. If voltage is OK at switch output, check ammeter.</p> <p>If no voltage into switch, locate and correct open.</p> <p>Test for voltage up to and out of ammeter. If low or zero output and input OK, replace ammeter, locate and fix open between switch and ammeter</p> <p>Disconnect harness at timer and check voltage pin B (of harness) to ground. If none, locate correct open.</p>
<p>Ammeter shows normal current part of cycle, zero current rest of cycle.</p>	<p>Open in wiring between timer and firewall connector.</p>	<p>Use heat test to find De-icers not heating and test for voltage on that pin of firewall connector.</p>

PIPER AZTEC SERVICE MANUAL

TABLE XIV-1. PROPELLER DE-ICER SYSTEM TROUBLESHOOTING (cont.)

Trouble	Cause	Remedy
<p>Ammeter shows normal current part of cycle, zero current rest of cycle (cont.)</p>	<p>Open in wiring between timer and firewall connector.</p> <p>Open between firewall and De-Icer lead straps.</p> <p>No ground circuit, one engine.</p>	<p>tor. If zero over 2 minutes, locate and fix open in wiring from timer to firewall.</p> <p>If voltage OK to firewall plug, try voltage at junction of De-Icer lead and slip ring lead. If no voltage, find and correct open in wiring to brush block, open within brush block or no contact brush to slip ring.</p> <p>If voltage at De-Icer leads, locate and fix open from De-Icer to ground.</p>
<p>Ammeter shows normal current part of cycle, low current rest of cycle.</p>	<p>Inner and outer De-Icers heating same phase.</p> <p>Open in De-Icer or slip ring assembly.</p> <p>High resistance in circuit with low current.</p>	<p>Locate and repair incorrect connections.</p> <p>Disconnect De-Icer straps to check heater resistance as in para. I4-30. If OK, locate and fix open in slip ring leads. If not, replace De-Icer with open circuit.</p> <p>If not in contact of brush to slip ring (including ground brush), trace wiring to De-Icer and</p>

PIPER AZTEC SERVICE MANUAL

TABLE XIV-I. PROPELLER DE-ICER SYSTEM TROUBLESHOOTING (cont.)

Trouble	Cause	Remedy
Ammeter shows normal current part of cycle, low current rest of cycle. (cont.)	High resistance in circuit with low current. (cont.)	to timer to fix partially broken wire, loose or corroded connection.
Ammeter shows low current over entire cycle.	Airplane voltage low. Ammeter faulty. High resistance up to timer.	Check voltage into switch. Test for voltage up to and out of ammeter. If low or zero output and input OK, replace ammeter. If no voltage to ammeter, locate and fix open between switch and ammeter. Check for partially broken wire, loose or corroded connection in wiring from airplane supply to timer input.
Ammeter shows excess current over entire cycle.	Ammeter faulty. Ground between ammeter and timer.	Test for voltage up to and out of ammeter. If low or zero output and input OK, replace ammeter. If no voltage to ammeter, locate and fix open between switch and ammeter. Disconnect harness at timer and, with ohmmeter, check from pin B (of harness) to ground.

PIPER AZTEC SERVICE MANUAL

TABLE XIV-1. PROPELLER DE-ICER SYSTEM TROUBLESHOOTING (cont.)

Trouble	Cause	Remedy
Ammeter shows excess current over entire cycle. (cont.)	Ground between ammeter and timer. (cont.)	If ground is indicated, locate and correct.
Ammeter shows normal current part of cycle, excess current rest of cycle.	<p>Ground between timer and brush block.</p> <p>Ground between brush block and De-Icers. (Excluding ground brush circuit.)</p> <p>Short between two adjacent circuits.</p> <p>Timer faulty.</p>	<p>Disconnect leads at brush block and, with ohmmeter, check from power leads to ground. If ground is indicated, locate and correct.</p> <p>If no short exists at brush-slip ring contact, check for ground from slip ring lead to bare prop while flexing slip ring and De-Icer leads. If a ground is indicated, locate and correct.</p> <p>Check for shorts or low resistance between circuits, if any, locate and correct.</p> <p>Test timer as in para. 14-29.</p>
Ammeter does not "flick" each 30 seconds.	Timer ground open.	Disconnect harness at timer and check with ohmmeter from Pin A or G (of harness) to ground. If no circuit, fix open per appropriate schematic diagram.

PIPER AZTEC SERVICE MANUAL

TABLE XIV-I. PROPELLER DE-ICER SYSTEM TROUBLESHOOTING (cont.)

Trouble	Cause	Remedy
Ammeter does not "flick" each 30 seconds.	Timer contacts are welded (caused by short circuit in system).	Test timer as in para. 14-28. If timer does not cycle with voltage at pin B, replace timer but be sure short causing original failure has been located and corrected.
Ammeter flicks between 30 second phase periods (confirm by ground test as in paragraph 14-25, g.)	<p>Loose connection between airplane power supply and timer input.</p> <p>Loose or poor connection timer to De-Icers.</p> <p>Timer cycles erratically.</p>	<p>If trouble occurs over entire cycle, trace wiring from power source to timer input to locate and tighten loose connection.</p> <p>If trouble occurs part of cycle, find which De-Icers are affected and check for rough or dirty slip rings causing brush to "skip". If not this, trace circuits to locate and fix loose or poor connection. (If all De-Icers on one prop are affected, check the ground circuit.)</p> <p>Test timer as in para. 14-28.</p>
Radio noise or interference with De-Icers on.	Brushes "arcing"	Check brush alignment as in para. 14-25, f. Look for rough or dirty slip rings. If this is the

PIPER AZTEC SERVICE MANUAL

TABLE XIV-I. PROPELLER DE-ICER SYSTEM TROUBLESHOOTING (cont.)

Trouble	Cause	Remedy
Radio noise or interference with De-Icers on. (cont.)	<p>Brushes "arcing". (cont.)</p> <p>Loose connection.</p> <p>Switch faulty.</p> <p>Wiring located within 8" of radio equipment wiring.</p>	<p>cause, clean, machine or replace slip ring assembly. Check slip ring alignment per paragraph 14-51.</p> <p>Refer to next preceding Trouble.</p> <p>Try jumper wire across switch - if radio noise disappears, replace the switch.</p> <p>Relocate at least 8" from input wiring to radio equipment.</p>
Cycling sequence not correct.	Crossed connections.	Check system wiring against circuit diagram for improper connections.
Rapid brush wear or frequent breakage.	<p>Brush block out of alignment</p> <p>Slip ring wobbles.</p>	<p>Check brush alignment as in paragraph 14-25, f.</p> <p>Check slip ring alignment with dial indicator as in paragraph 14-51.</p>

14-32. OVERALL PROCEDURES.

14-33. USE OF CORRECT PARTS. The type and number of De-Icers determine the system current drain. The ammeter and the switch are designed to operate at such specific current. Accordingly, any mixing of De-Icer part numbers on the same airplane or the use of the incorrect ammeter or switch will affect system operation. The parts manual should be followed closely.

CAUTION

Guard against installing two different part number De-Icers on the same propeller or the same airplane. This will throw the De-Icer system out of balance electrically.

14-34. ELECTRICAL.

a. For soldering, use Kester "Resin Five" core solder, 0.062 strand No. 66 or equal. Where flexibility of wire lead is vital, as in brush leads, etc., guard against applying excess solder which would stiffen the wire or joint. This condition is called "wicking" and must be held to 0.125 inch maximum on brush leads. Use care that solder does not deposit on brushrod below barrel when soldering brush leads as this may cause brush to hang up or bind.

b. In crimping terminals to wire, use proper tool and see that terminal is crimped to bare wire, not on insulation. If wires are found too short to repair, replace with same grade and quality, dressed along harness.

c. Bent pins in connectors may be straightened with long nose pliers but check that work hardening does not leave pin brittle and susceptible to breakage. If in doubt, replace the connector. Similarly, minor damage to connector threads may be repaired. Major damage requires replacement.

d. Locate leads and harnesses to be at least eight inches away from radio wiring to avoid radio noise or radio compass interference. Chafed or worn harness areas indicate need to redress the wiring. If not too badly damaged, chafed areas may be wrapped well with insulating tape and covered with vinyl tubing. If in doubt, replace the affected wires or harness.

14-35. MECHANICAL. Use safety wire at timer, wire harnesses, brush block assembly, slip ring, and at hub clamp and clip of blade De-Icers where found at disassembly and wherever provisions are made for its use.

14-36. BALANCING WEIGHTS. For procedure when balancing weights of Hartzell propellers are removed or installed, refer to B. F. Goodrich Service Bulletin E-61-12.

14-37. PROPELLER MARKINGS. For procedure when identification of Hartzell propellers are affected by De-Icer installation, refer to B. F. Goodrich Service Bulletin E-63-20.

14-38. SWITCH, CIRCUIT BREAKER, AMMETER, TIMER, HARNESS.

a. Tighten loose mechanical mounting hardware and/or loose electrical connections but avoid excess force which might strip threads. If replacement is found necessary, replace with the correct part number. Use the same or equivalent hardware to mount and make electrical connections as in the wiring diagrams. Note that airplane power supply lead ties to positive ammeter terminal, negative terminal connects to pin B of connector plug at timer.

14-39. BRUSHES. When replacing brushes or brush retainer assemblies, always install new springs.

14-40. BRUSH REPLACEMENT AS SUB-ASSEMBLY. (PA-23-250; PA-23-235 and PA-23-250 (six place), Serial Nos. 27-2000 to 27-2504 incl.) (Refer to Figure 14-20.) Dismount the brush insert assembly by taking out the mounting screws and associated hardware at the point labeled (1). Disconnect brush leads at the studs noting the studs to which the leads of the top, middle and bottom brushes are connected. Now take out the screws (2) and associated washers to pull out the brush retainer assembly (3) which includes the brushes, springs and the retainer. Slip the brushes of the new sub-assembly into the slots of the holder and mount the new sub-assembly with screws (2) and associated washers. Connect the brush leads to the studs exactly as noted in removal and check against the wiring diagrams in Figures 14-18 and 14-19 if in any doubt. Mount the brush insert assembly with the screws and associated hardware at (1). (Refer to Paragraph 14-44.)

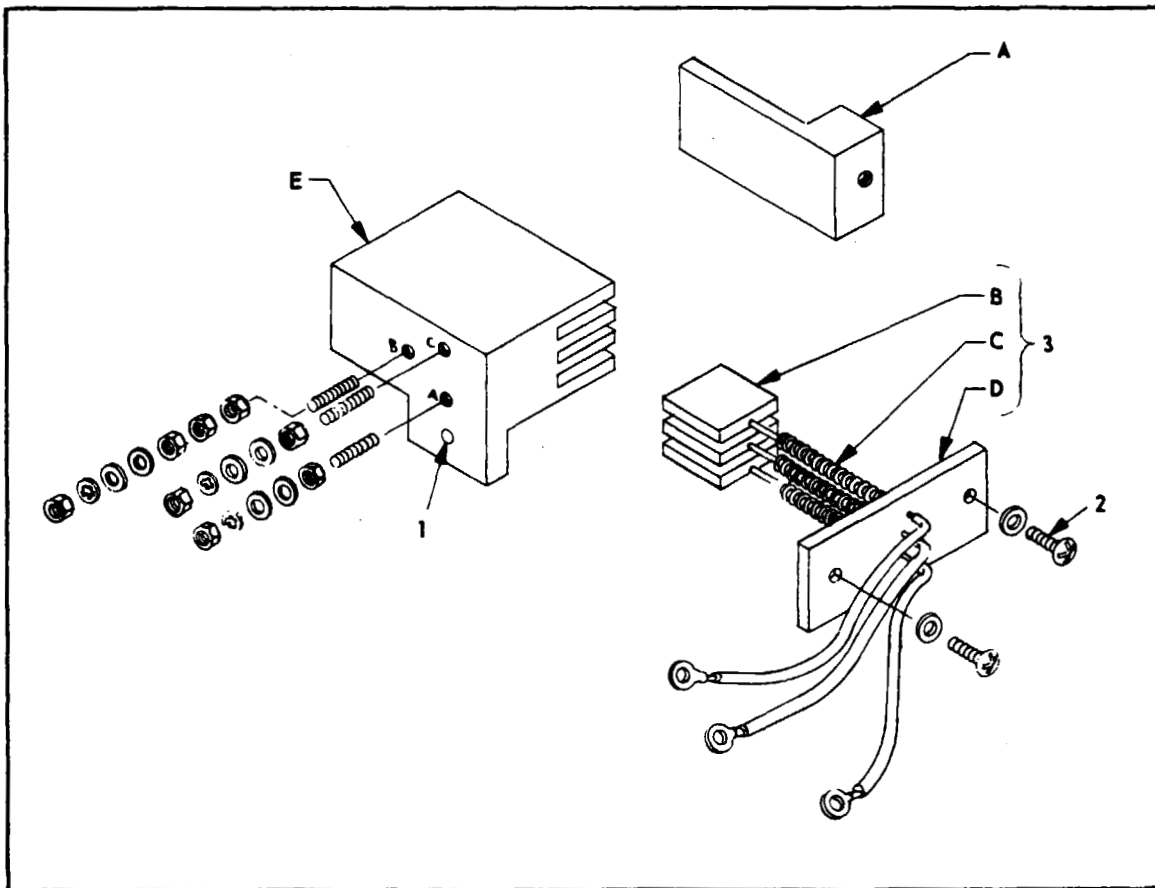

Figure 14-20. Brush Insert Assembly,
PA-23-250; PA-23-235; and PA-23-250 (six place),
Serial Nos. 27-2000 to 27-2504 incl.

14-41. BRUSH REPLACEMENT AS SUB-ASSEMBLY. (PA-23-250 (six place), Serial Nos. 27-2505 and up.) (Refer to Figure 14-21.) Take out screws at point labeled (1) and associated washers to dismount the brush block assembly. Next, remove screws (2) and their washers to slip the smaller block off the brush retainer assembly (3) which includes the brushes, springs, electrical connector and the larger block. Slide the smaller block onto the new brush retainer assembly (3) in the direction of brush travel to pass over the brushes and to then compress the springs. Use care that no side load is applied on brushes and that leads are not pinched or damaged. Install screws (2) with their washers to mount the smaller block to the larger and check for free sliding motion of the brushes. Mount the brush block assembly with the screws at point (1) and associated hardware. (Refer to Paragraph 14-44.)

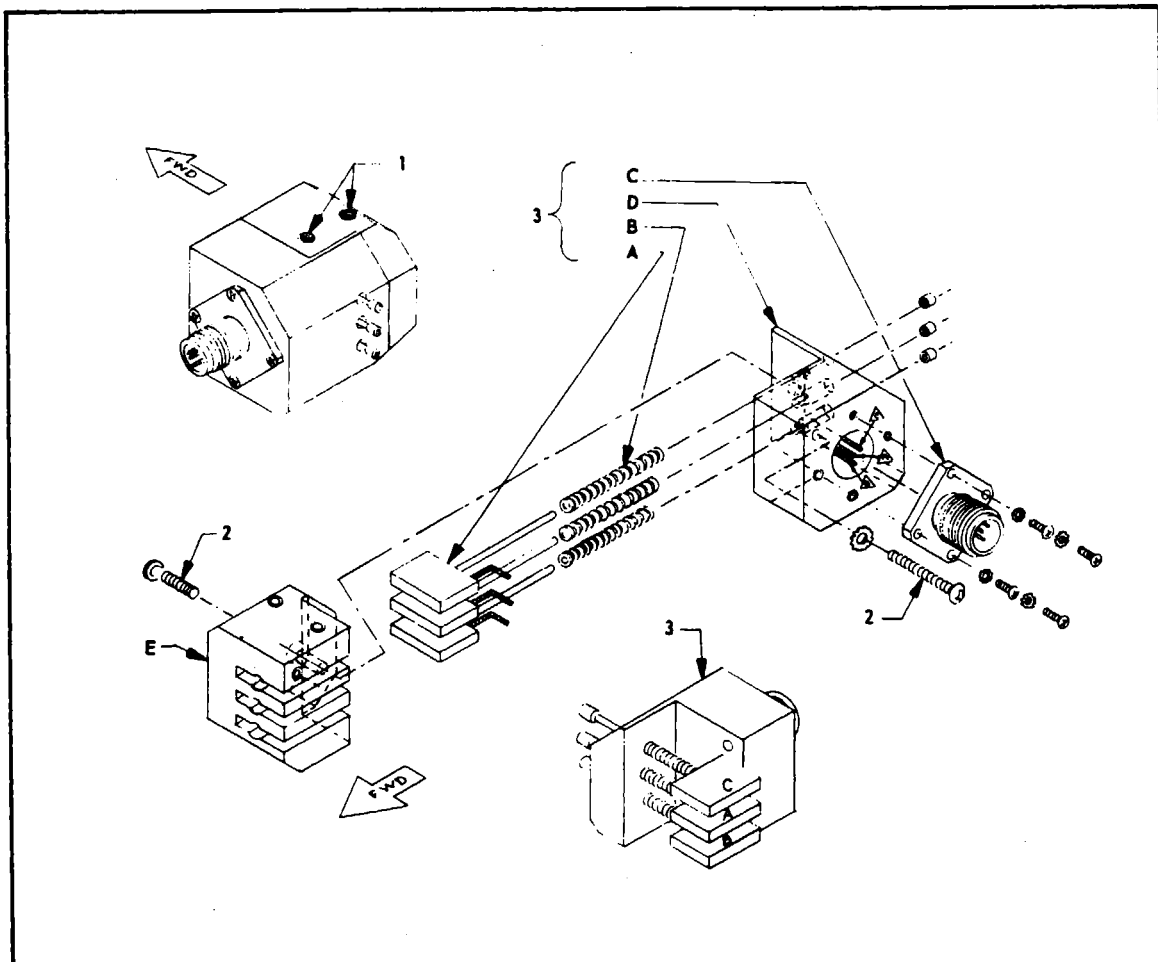

Figure 14-21. Brush Block Assembly,
PA-23-250 (six place), Serial Nos. 27-2505 and up

PIPER AZTEC SERVICE MANUAL

14-42. REPLACING INDIVIDUAL BRUSHES. (PA-23-250; PA-23-235; and PA-23-250 (six place), Serial Nos. 27-2000 to 27-2504 incl.) Remove brush insert assembly by taking out screws at point labeled (1) of Figure 14-20 and associated hardware. Use tape or rubber band to hold brushes in place while the assembly is gently locked in a vise. (Refer to Figure 14-22.) With soldering gun or iron, free soldered lead and barrel from end of brush rod of brush to be replaced. Loosen tape or rubber band to draw out the old brush and its spring. Install new spring and brush, hold with rubber band or tape. Now solder barrel and brush lead to end of brush rod - barrel must be flush with end of brush rod. (Work on one brush at a time and use the undisturbed brush rods adjacent to see how barrel is to be set.) In this step, see that width of braid lead lies parallel to the retainer plate. Avoid excess solder that would stiffen brush lead - 0.125 of an inch "wicking" is maximum allowable. Brush rods must be free of solder between "B" barrel and brush. (Refer to Paragraph 14-44.)

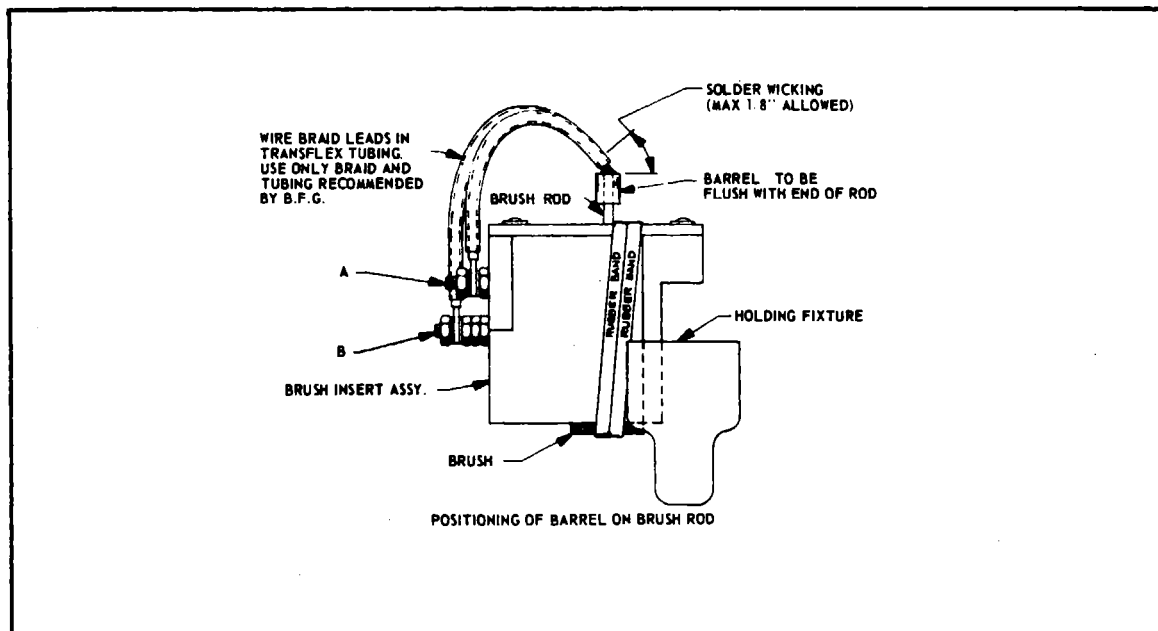

Figure 14-22. Holding Brushes for Soldering, PA-23-250; PA-23-235; and PA-23-250 (six place), Serial Nos. 27-2000 to 27-2504 incl.

14-43. REPLACING INDIVIDUAL BRUSHES. (PA-23-250 (six place), Serial Nos. 27-2505 and up.) Remove brush holder and disassemble brush retainer assembly as in paragraph 14-41, then use rubber band or tape to hold brushes compressed in block as in Figure 14-23. Take out hardware to free the connector and pull it out just so that the leads of the brush to be replaced can be unsoldered. Unsolder the barrel at the end of the brush rod to remove the old brush and its spring. Install a new spring and new brush in the block and hold under rubber band or tape to solder the barrel flush with the end of the brush rod. Barrel must be concentric with brush rod. Brush rod and barrel must be free of solder on its external surface as this may cause brush to hang up. Now solder the brush lead to the connector pin. Remount the connector and reassemble the brush block assembly. Check for free sliding motion of brushes before mounting on the airplane. (Refer to Paragraph 14-44.)

14-44. ALIGNMENT AND RUN-IN OF NEW BRUSHES.

- a. At any time that brush block assembly is dismounted, the alignment at re-installation must be checked as described in paragraph 14-25, f.
- b. New brushes must be run-in for a minimum of five (5) hours engine operation before the De-Icer system is turned on. This applies whether brushes have been replaced individually or as subassemblies. This requirement does not prevent static operating checkout.

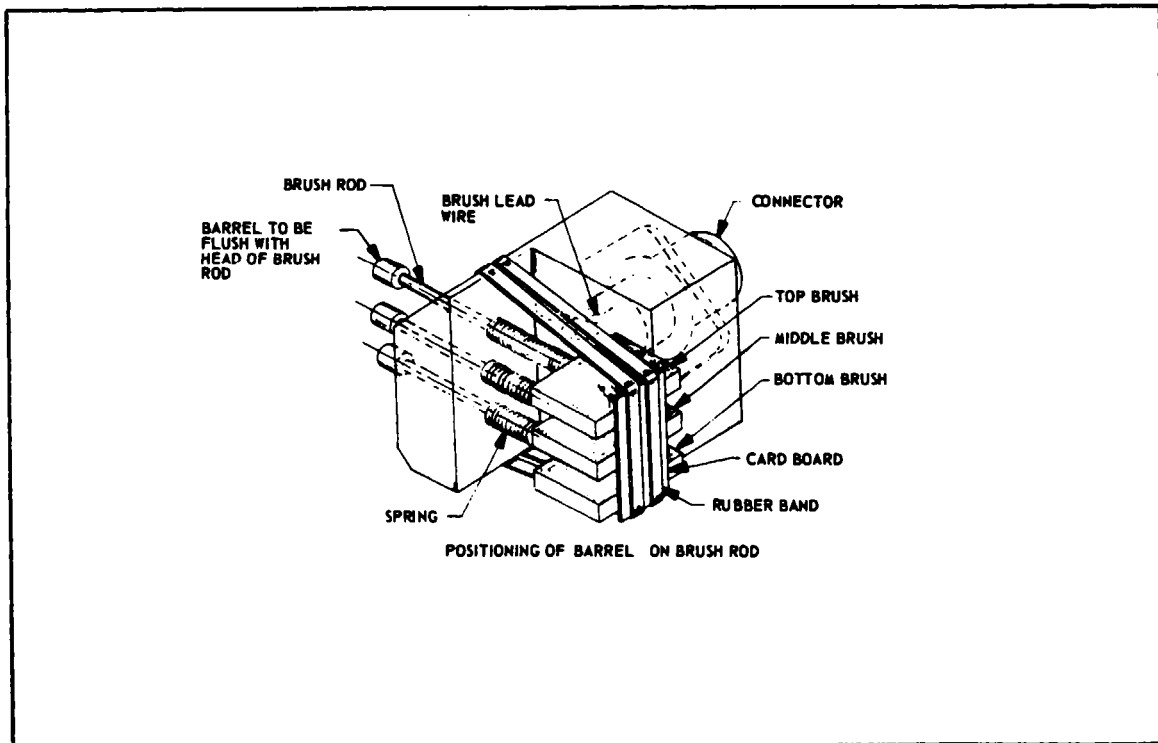

Figure 14-23. Holding Brushes for Soldering, PA-23-250 (six place), Serial Nos. 27-2505 and up

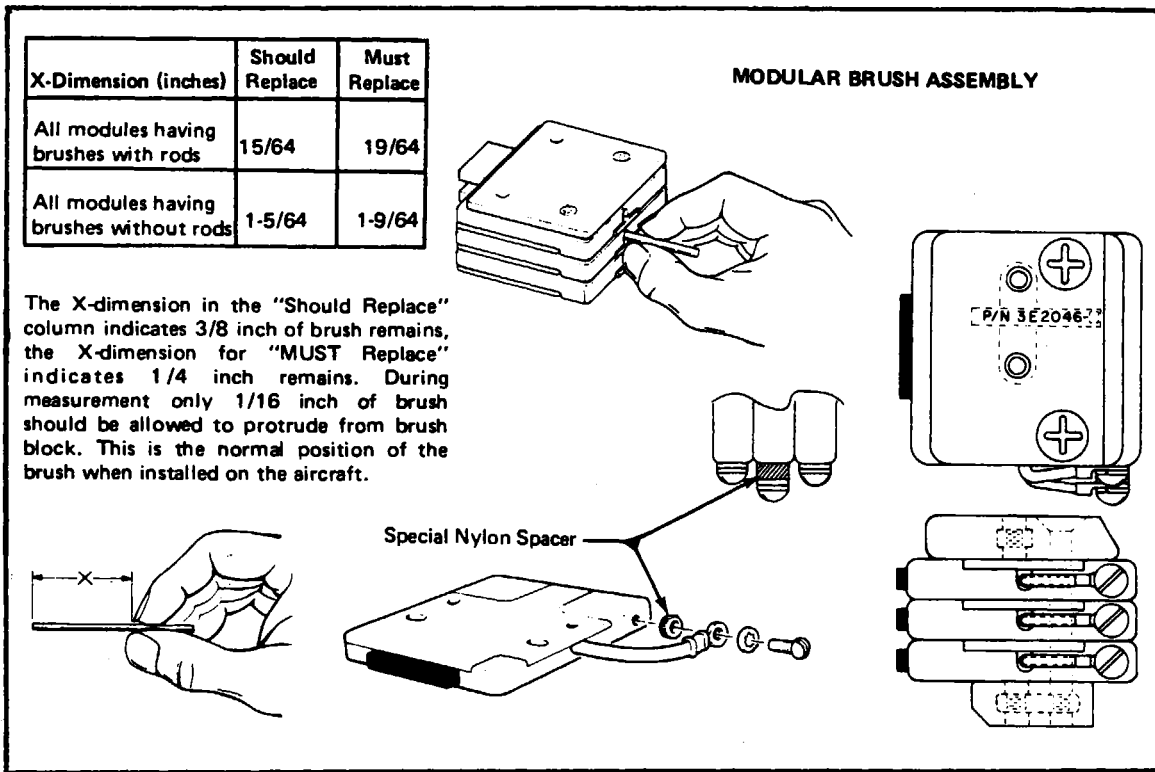

Figure 14-24. Modular Brush Assembly

14-45. MODULAR BRUSH ASSEMBLY REPLACEMENT FOR BRUSH BLOCK ASSEMBLY. Modular brush assembly part number 3E2046-1, is a direct replacement for brush block assembly 4E1515-3. Instructions concerning replacement of brush block assemblies with modular brush assemblies are given in B.F. Goodrich Service Bulletin No. E-77-54.

14-46. MODULAR BRUSH ASSEMBLY MAINTENANCE. Brushes are not offered individually as replacements. When a brush wears out, the module containing it should be replaced as follows:

- a. Remove the modular brush assembly from the aircraft by removing attaching hardware and disconnect the wire harness.
- b. Remove assembly screws and separate module and spacers.

NOTE

The part number of each module is etched into the surface of the plastic housing. Replace with the same part number module.

c. Restack modules and spacers as shown in Figure 14-24. If there is interference between adjacent ring terminals, reorient center module as shown in Figure 14-24.

NOTE

Ascertain flat washer is positioned between star washer and housing.

- d. Reconnect aircraft wire harness and insure adjacent ring terminals are not touching.
- e. Install assembly on aircraft and check alignment.

14-47. SLIP RINGS.

14-48. MACHINING. If structurally sound, slip rings with roughened or damaged surfaces can be machined to restore to serviceability. Remove the slip ring assembly from the airplane to mount it in a lathe, located concentrically in the lathe and with not over 0.002 wobble or run-out over 360 degree rotation. Take light cut for smooth finish and cut no deeper than required to remove surface damage. Contact surfaces of the three slip rings must be parallel within 0.005 inch and flat within 0.005 inch overall - deviation from flat not to exceed 0.002 inch over a 4 inch arc. If necessary, undercut insulation between slip rings to a depth of 0.020 to 0.030 inches below the contact surface of the slip rings. In this operation, width of slip ring must not be reduced more than 0.005 inch. Contact surface of slip rings must have a finish of 29-35 micro inches. De-burr slip ring edges and re-install in the airplane, and align per paragraph 14-51.

NOTE

If, in machining, the solder or braze connection on the underside of the slip ring is exposed, replacement of the slip ring assembly will be necessary.

14-49. REPLACEMENT. Slip ring assemblies that are open or shorted electrically, cracked or damaged structurally, or which have damaged surfaces beyond the scope of minor repair to clean up, should be replaced with a new slip ring assembly. When replacing, align slip ring assembly per paragraph 14-51 and allow brushes to run-in for a minimum of 5-hours engine operation before turning on De-Icer system, except static operating checkout.

14-50. TORQUE LIMITS. Some systems use a stud brazed to the slip ring for making electrical connection. In any work around these studs, avoid side loads on the studs which may lead to ultimate breaking of the brazed joint and consequent failure of the slip ring.

CAUTION

Excess torque is apt to pull studs from slip rings. In installing or tightening nuts, use torque wrench and tighten to 10 to 12 inch-pounds only.

14-51. **ALIGNMENT.** (This step not applicable to slip rings on starting gears.) Check slip ring run-out with dial indicator set-up as in Figure 14-15.. Push in on prop as it is turned to take out play of prop thrust bearing which would affect readings. If the total run-out exceeds 0.005 inch or exceeds 0.002 inch in a 4 inch arc, alignment must be accomplished as follows:

a. Use AN960C416L washers between slip ring and spinner bulkhead to shim for true running. If necessary, fabricate thinner shims to AN960 size.

NOTE

If no toothed washer is used in original mounting, install AN936B416 between two AN960C416L plain washers plus any shims required. The AN936 washers provide an adjustable method of shimming. This change will affect brush block clearance which must be readjusted as in paragraph 14-25, f.

b. In mounting slip ring assembly to spinner bulkhead, snug mounting bolts to approximately 25 inch-pound of torque. Using the dial indicator to follow the points of maximum deviation, adjust slip ring assembly to prescribed run-out by gradual tightening of mounting bolts until all are within 40 to 75 inch-pounds of torque.

14-52. **ECCENTRIC RUNNING.** If brush block cannot be adjusted sufficiently to prevent brushes from riding partially off the edge of the slip rings at any point through 360 degree rotation, the spinner bulkhead must be replaced to permit proper mounting of the slip ring assembly. There is no adjustment for this condition.

14-53. **BLADE DE-ICERS.**

14-54. **REPLACEMENT.** If tests show the blade De-Icer to have an open circuit, to be the wrong resistance or to be visibly damaged beyond repair procedures as outlined in paragraph 14-56, replace the De-Icer. Use the correct part as specified, for replacement.

14-55. CEMENTING PROCEDURE. Use B. F. Goodrich Field Repair Kit No. 77-802 which contains rubber patch material, sponge rubber material, and rubber tubing sufficient for several repair jobs. Cements and solvents specified in these directions are not included in the kit. (The abbreviation "MEK" in further steps stands for Methyl ethyl ketone.) The following steps apply wherever "cementing" is specified in the text:

a. Clean the metal or rubber area to be bonded or patched with MEK or acetone to remove all grease and dirt.

NOTE

It is permissible when installing deicer boots on Hartzell Polane coated propeller blades, to rough the surface with fine sandpaper; remove all grit with air; then clean with acetone. MEK is NOT acceptable for cleaning Polane coated propellers. Proceed with standard installation.

It is vital that surface be clean for a good cementing job. After the last wipe with cleaner, quickly wipe surface with a clean, dry lint-free cloth to remove solvent film.

b. Apply one even coat of EC-1300L cement (Minnesota Mining and Mfg. Co.) to area being bonded or patched and allow to dry (approximately 1 hour above 40 degrees F). Apply a second even coat of EC-1300L cement and allow to dry.

c. Cut patching or sponge material as directed in the specific repair step. This material is exposed to airstream, cut clean edges (without fringes) and bevel. On the thicker (0.020 inch) rubber, the protective paper is on the side to be cemented. Apply masking tape on the open side to prevent the patch from curling as cement dries; then strip off protective paper and apply EC-1300L cement in a smooth even coat. Allow to air dry. On the thinner (0.010) rubber, the mylar coating is on the air side and helps to prevent the patch from curling. Wipe the open side with MEK or acetone to clean; follow last wipe immediately with clean, dry lint-free cloth wipe, and apply smooth even coat of EC-1300L cement. Allow to air dry. On sponge material, the rough side is to be cemented. Use MEK or acetone to clean this surface but avoid soaking sponge with the solvent. Apply smooth even coat of EC-1300L cement to rough surface and allow to air dry. After 1 hour, apply second coat and allow to air dry.

d. With cemented surfaces either dry or with just a trace of "tackiness," apply light coat of MEK or Toluol over these surfaces to "re-tackify" and quickly complete the cementing job as directed in the step. Allow one hour to air dry before peeling off the masking tape or mylar coating on the air side. Rub edges and center of patch to see that it is holding before releasing for flight.

NOTE

Do not touch cemented surface with dirty or oily fingers.

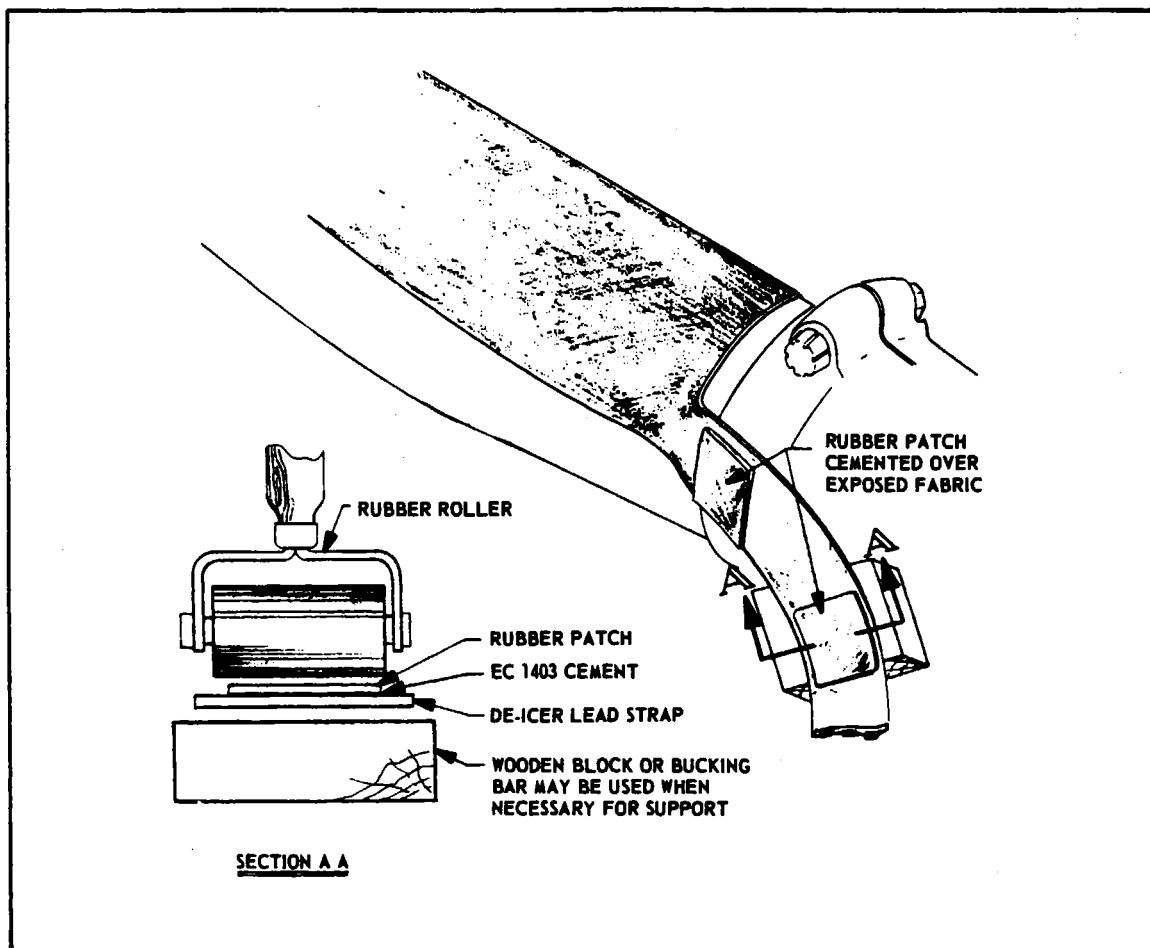

Figure 14-25. Patching De-Icer Lead Strap

14-56. **BLADE DE-ICER SURFACE, OUTBOARD OF CLAMP.** Cut the patch (0.010 inch rubber) to be about 0.25 of an inch larger on all sides than the damaged area. In setting the re-tackified patch into place, use rubber roller to press patch firmly - a metal roller will damage the wires within the De-Icer. (Refer to Figure 14-25.)

a. If the wires are exposed but not broken (in the De-Icer element), use two plies of 0.010 inch rubber to patch. Place the first patch on as described above and allow to dry one hour. Cut the second patch to be 1/4 inch large on all sides than the first patch. Follow the given procedure to cement the second patch in place and allow one hour to air dry.

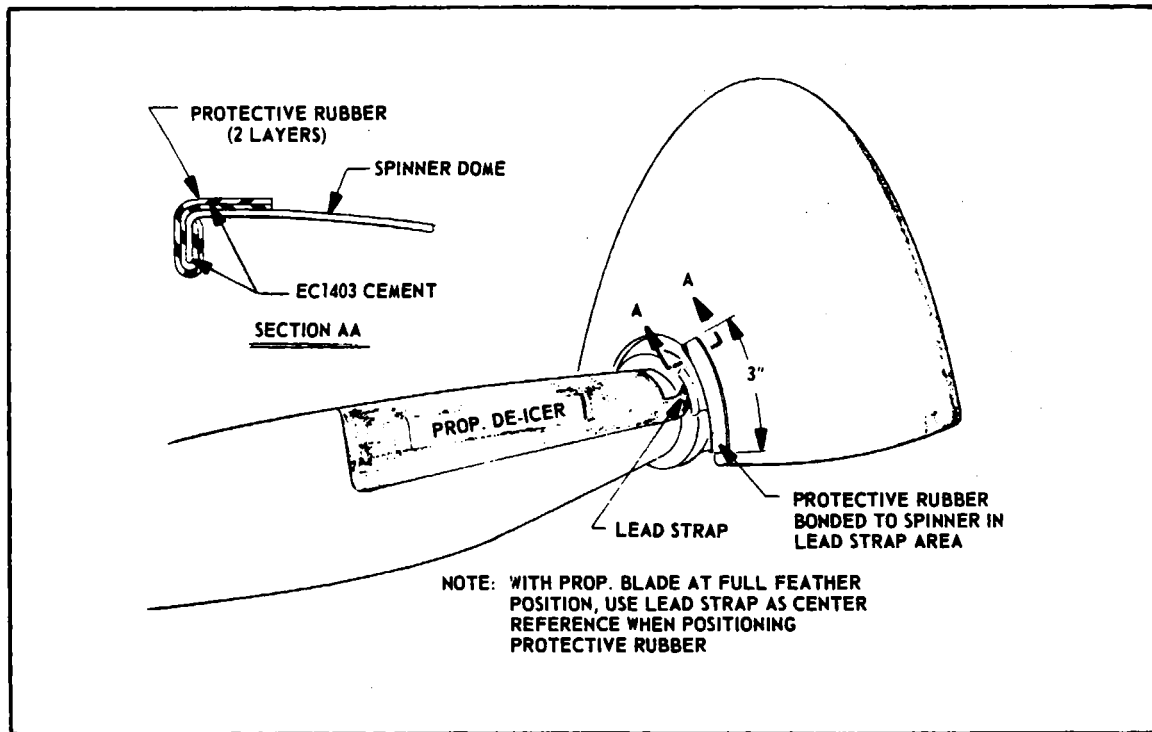

Figure 14-26. Spinner Dome Cushioning

14-57. **BLADE DE-ICER LEAD STRAP.** Cut the patch (0.020 inch rubber) to be about 1/4 inch larger on all sides than the damaged area. Use rubber roller to press the patch into place - a metal roller will damage the wires in the strap. (Refer to Figure 14-25.)

14-58. **SPINNER DOME STRIP.** Cut two pieces, each 5/8 by 3 inch of 0.020 inch rubber to fit as shown in Figure 14-26. Lightly sand metal to remove all paint in area to be cemented. Follow the given procedure to cement the first piece in place and allow one hour to air dry. Now cement the second piece over the first and allow one hour to air dry.

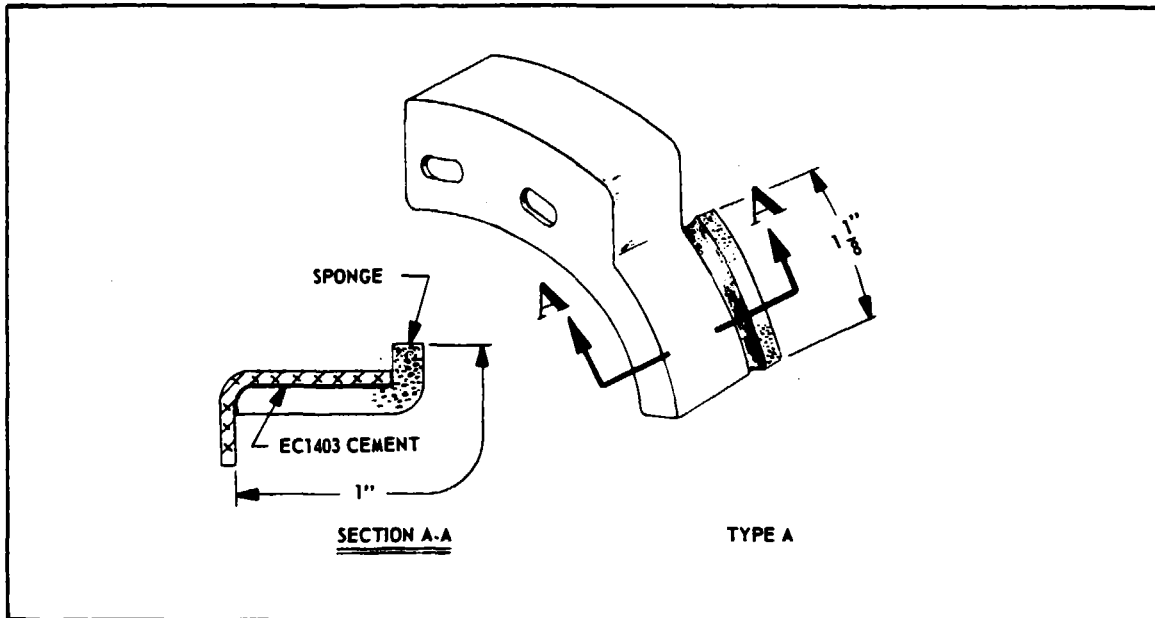

Figure 14-27. Hub Clamp Cushioning

14-59. **CLAMPSPONGE CUSHION.** (Refer to Figure 14-26.) If cushioning sponge is frayed or damaged, use MEK or toluol liberally to remove old sponge. In such case (or if the sponge cushion is missing), clean metal thoroughly. Cut the sponge 1 by 1-1/8 inches (for type "A" clamp, Figure 14-27) and follow the given procedure to cement sponge into place, pressing firmly with fingers.

14-60. **WRINKLED DE-ICERS.** If edge of De-Icer is found wrinkled or loose, try recementing. Use MEK or toluol to loosen the bond for an additional 1/4 inch beyond the loose or wrinkled area. Apply one coat of EC-1300L cement to the De-Icer and prop bonding surfaces and allow to air dry for one hour. Then apply a second coat of EC-1300L cement to both the De-Icer and prop bonding surfaces. Re-tackify with MEK or acetone and press with fingers to work out wrinkles or to secure loose edge. If material has stretched and will not cement flat, replace the De-Icer element.

NOTE

Use polyethylene or teflon film between De-Icer element and prop while cement coats are drying so that they do not stick together.

14-61. INSTALLATION OF DE-ICER STRAPS AND WIRE HARNESS.

- a. The De-Icer lead strap is fastened to the bulkhead in the same positions from which they were removed.
- b. The De-Icer strap is to be attached to the studs on the spinner bulkhead.

CAUTION

Never use Type "B" star washer (teeth on outer diameter) adjacent to tongue of De-Icer terminals.

- c. Make certain that there is no slack in the De-Icer lead strap between the terminals and the clip. This is important because it assures enough slack between the clip and the strap restrainer to allow for proper feathering. A test should be conducted on each propeller de-icing system to insure that De-Icer lead straps are installed in such a manner that the propeller can be moved from full low pitch through the feathering position without placing the straps in tension.

NOTE

De-Icers should have a piece of gray plastic bonded to the air side (shiny side) of the De-Icer strap as shown in Figure 14-28. . The strap restrainers should be positioned as shown in Figure 14-29 when the propeller blades are in the full feather position.

- d. If damage occurs to slip ring wire harness, rubber spacers or hose clamps, replace damaged parts.

14-62. OTHER COMPONENTS. Do not attempt internal repairs of the timer, ammeter or switch. If inoperative, these components must be replaced with one of the correct part number.

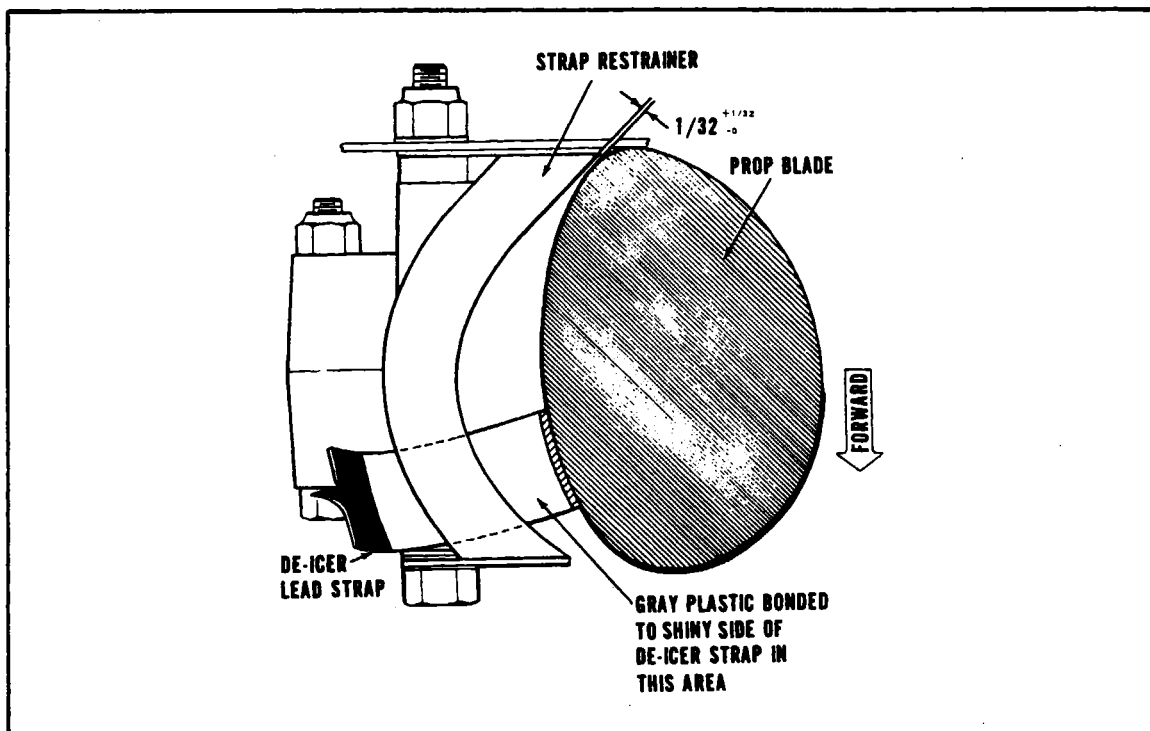

Figure 14-28. Propeller Blade in Low Pitch

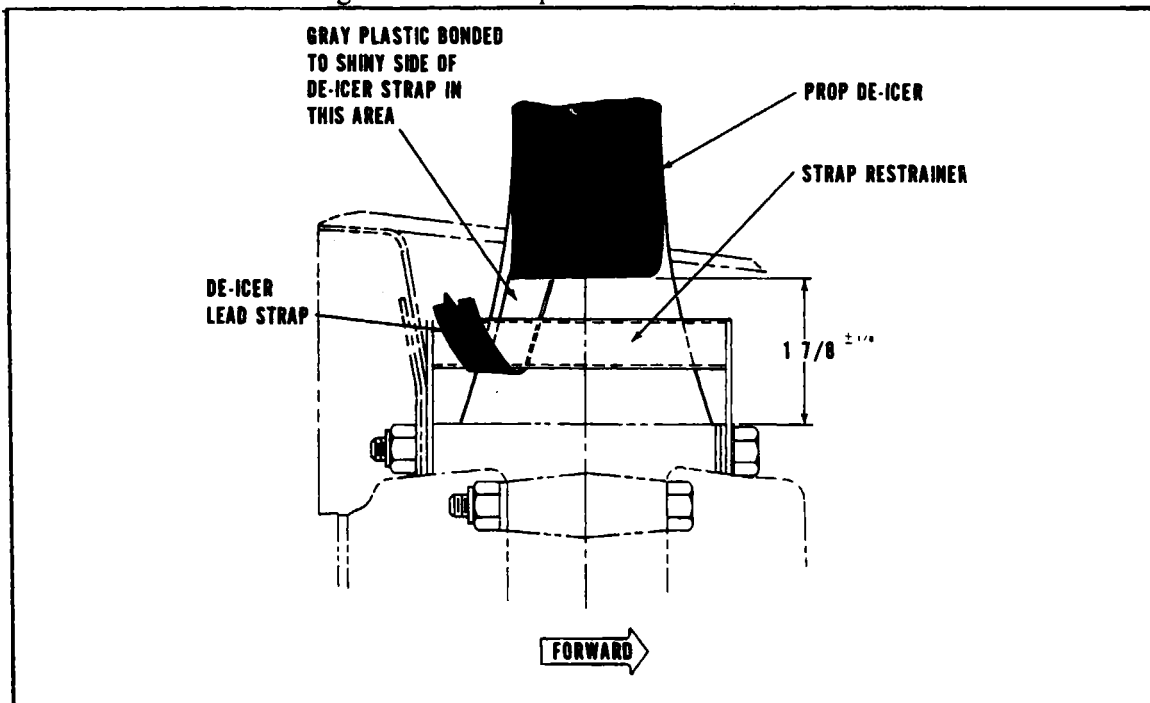

Figure 14-29. Propeller Blade in Feather Position

14-63. PNEUMATIC DEICER SYSTEM.

14-64. INTRODUCTION. This portion of Section XIV provides service and maintenance procedures for the pneumatic deicing systems used in these aircraft.

14-65. DESCRIPTION AND PRINCIPLES OF OPERATION. The deicer boot is essentially a fabric reinforced rubber sheet containing built-in inflation tubes. The type used in this installation have spanwise inflation tubes. Deicers are attached by means of a cement to the leading edges of the surface being protected. There are either aluminum or flexible rubber air connections on the backside of the boots called "air connection stems." Each stem projects from the underside of the boot into the leading edge, through a hole provided in the metal skin. The stems connect to the airplanes pneumatic air supply system.

The pneumatic deicing systems used on these airplanes are lightweight type having single inflation operation and utilize either the 28 volt or 14 volt electrical system. Refer to PA-23-250 Parts Catalog 753 522 for specific part numbers and serial numbers for the particular system and airplane being serviced. On single inflation systems, all the deicers on the wings and tail surfaces are inflated simultaneously in a single sequence.

There are three different systems used on this series of airplane models. The very early system provided automatic cycling operation once every three minutes during timer operation when the deicer system control switch is turned ON. On later installations the timer was replaced with a time module. With this system there is no continuous cycling of the system and it is not necessary to turn the system control switch OFF, as this is done automatically. The time module provides system operation for six seconds. The switch is a momentary ON type which returns to the OFF position when released. Should reactivation of the system be required, the control switch can be moved to the ON position again and released.

On still later installations the system incorporated an additional solenoid exhaust valve and indicator light. This system also uses a momentary ON toggle switch which also has a "MANUAL DEFLATE" position should the system malfunction with the boots inflated. This system does not use a timer or time module to regulate inflation time, instead two pressure switches are used to control system operation. When the system pressure reaches the preset inflation pressure, the pressure switches in conjunction with a relay breaks the circuit, thus de-energizing the solenoid valves and deflating the boots. If the system controlling pressure switch should fail, the second pressure switch acts as a back-up device to break the circuit. In the unlikely event that both of these switches failed, pressure is limited only by the maximum capability of the dry air pumps. This method of operation insures complete inflation of the boots regardless of altitude. There are two indicator lights which monitor system operation, a blue light indicates normal boot inflation and operation, while the red light indicates an over-pressure inflation condition, in which case the toggle switch is placed in the "MANUAL DEFLATE" position which de-energizes the three solenoid valves and returns the boots to the normal hold down position. Should reactivation of the system be required, the toggle switch can be moved to the ON position again and released.

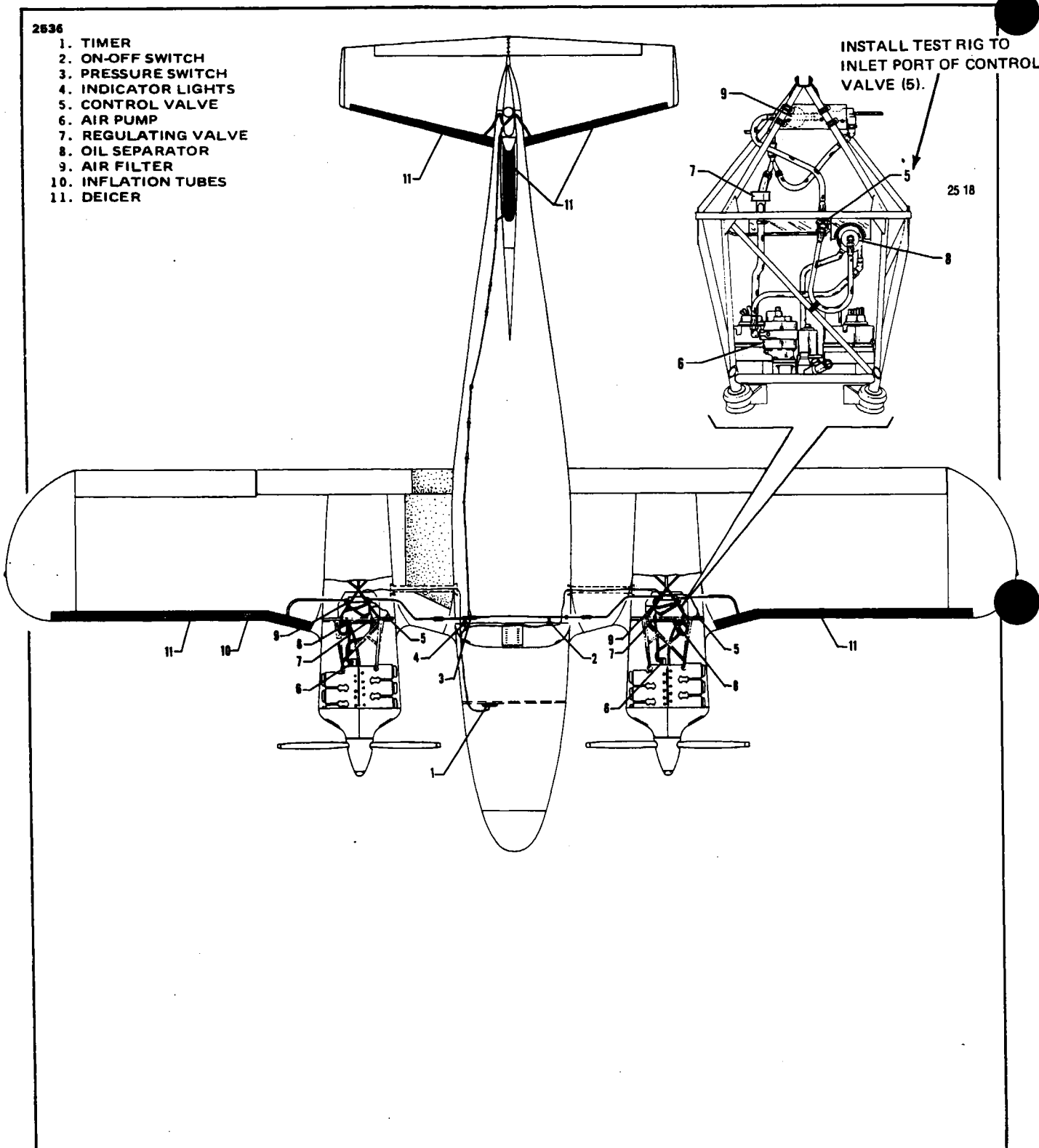

Figure 14-30. Pneumatic Deicing Installation (Wet Vacuum Pump),
Serial Nos. 27-2505 to 27-3944 inclusive

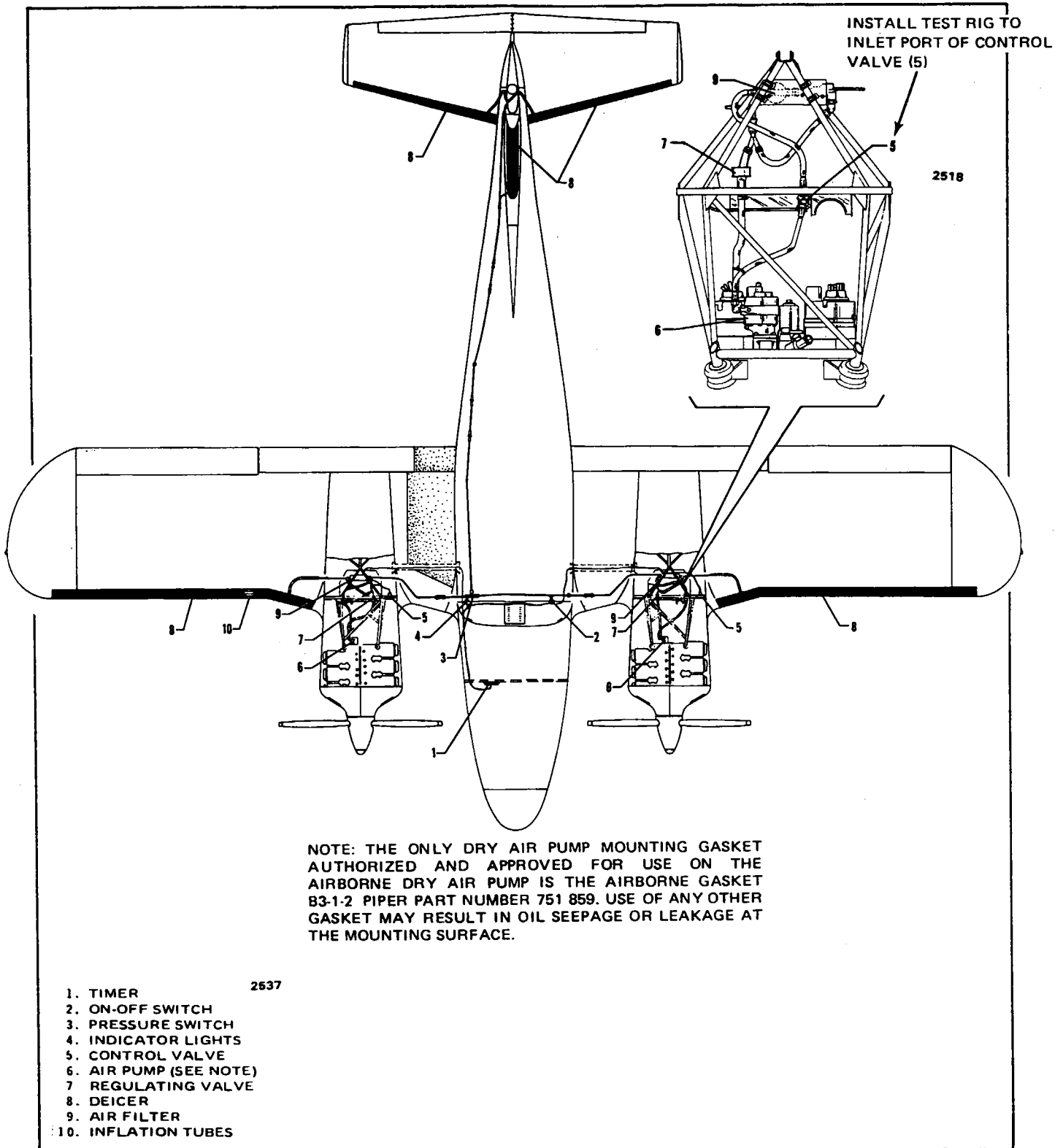
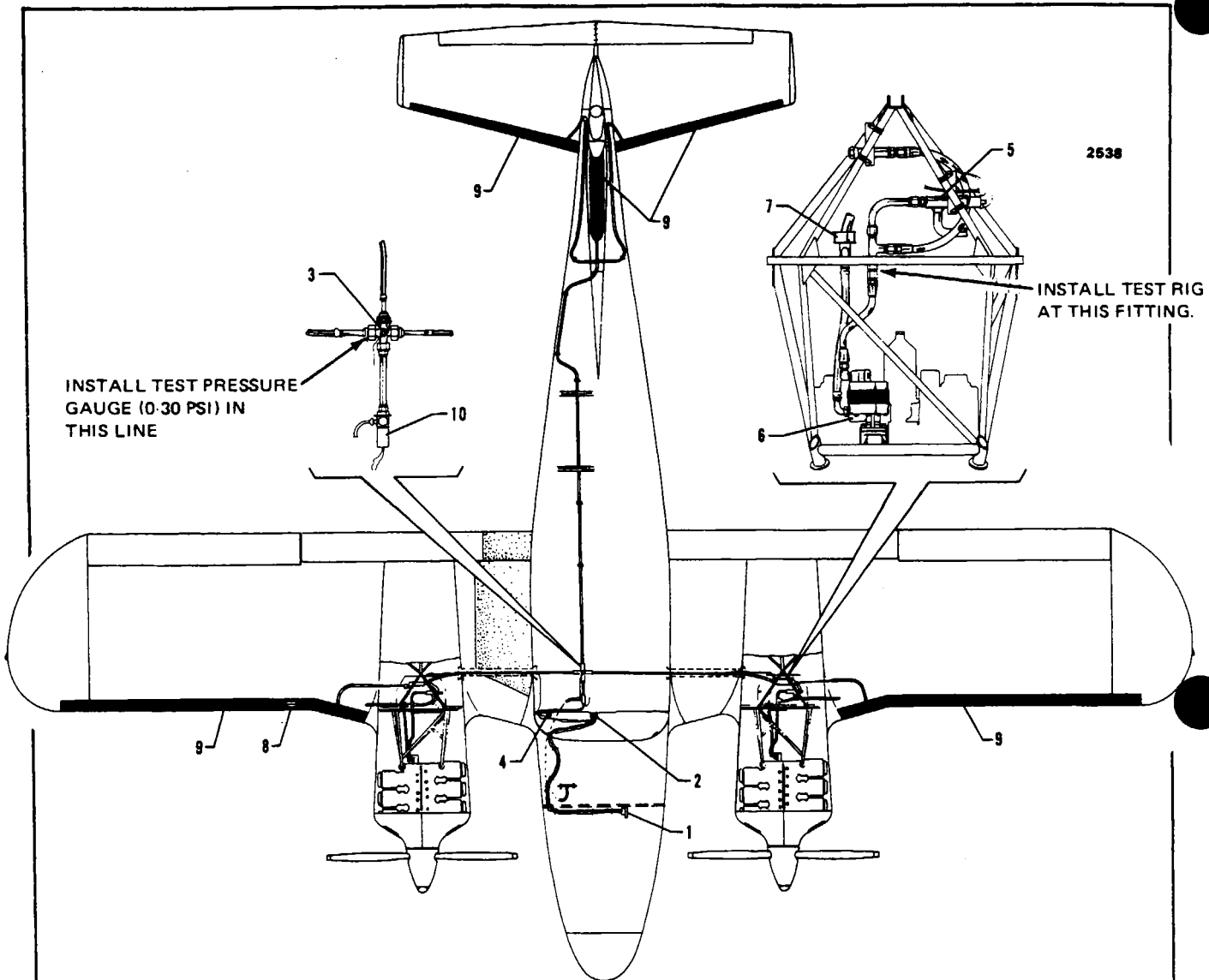

Figure 14-31. Pneumatic Deicing Installation (Dry Vacuum Pump),
Serial Nos. 27-4510 to 27-7304963; 27-7304965 to 27-7304993 inclusive



INSTALL TEST PRESSURE GAUGE (0-30 PSI) IN THIS LINE

INSTALL TEST RIG AT THIS FITTING.

NOTE: THE ONLY DRY AIR PUMP MOUNTING GASKET AUTHORIZED AND APPROVED FOR USE ON THE AIRBORNE DRY AIR PUMP IS THE AIRBORNE GASKET B3-1-2, PIPER PART NUMBER 751 859. USE OF ANY OTHER GASKET MAY RESULT IN OIL SEEPAGE OR LEAKAGE AT THE MOUNTING SURFACE.

- 2635
1. TIMER
 2. SWITCH ASSY. & CIRCUIT BREAKER
 3. PRESSURE SWITCH
 4. INDICATOR LIGHTS
 5. PRESSURE CONTROL VALVE
 6. AIR PUMP (SEE NOTE)
 7. REGULATING VALVE & FILTER
 8. INFLATION TUBES
 9. DEICER
 10. EXHAUST VALVE ASSEMBLY

Figure 14-32. Pneumatic-Deicing Installation (Dry Vacuum Pump),
Serial Nos. 27-7304964 to 27-7554168 inclusive

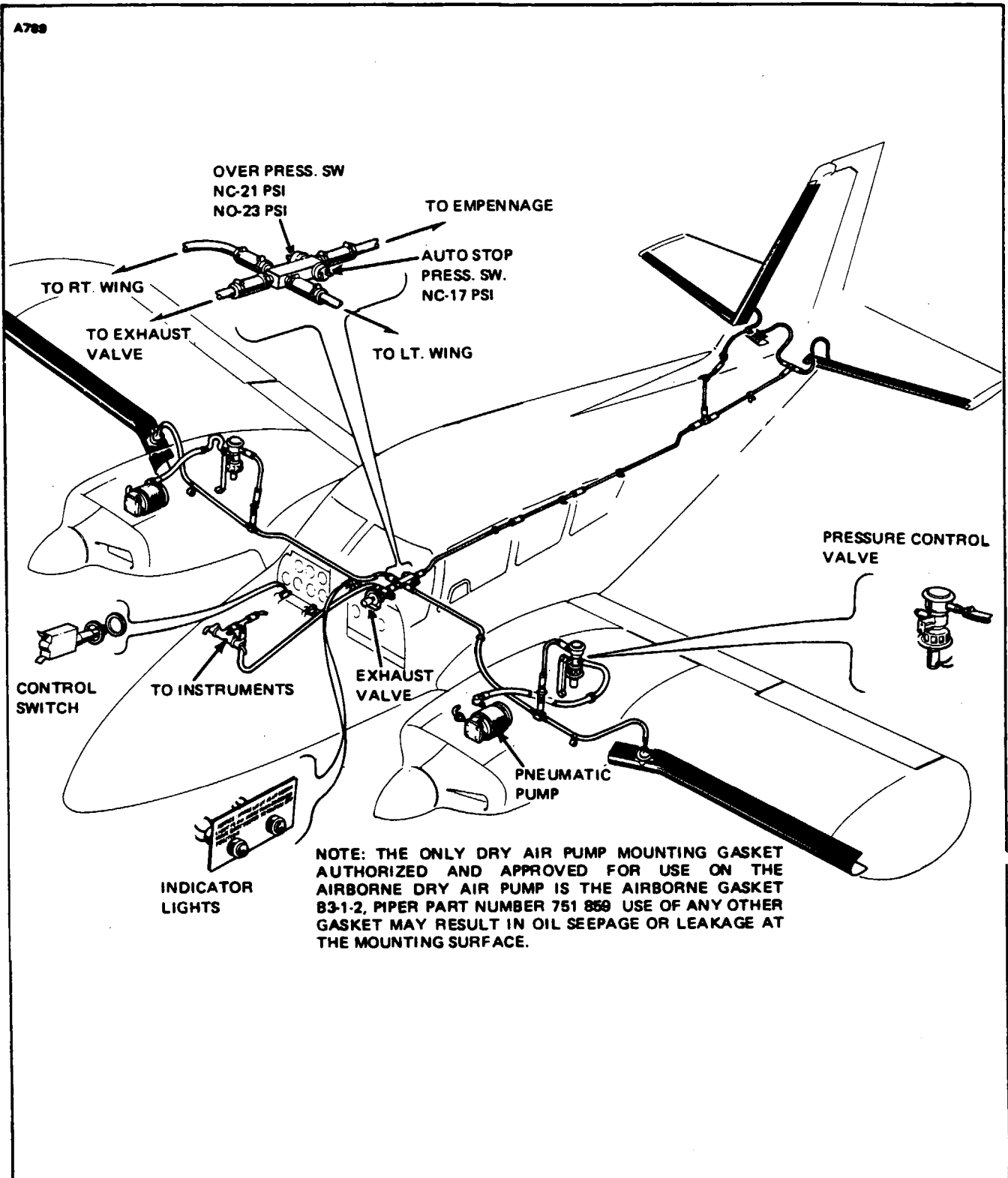

Figure 14-33. Pneumatic Deicer Installation (Dry Vacuum Pump),
Serial Nos. 27-7554112 to 27-7554168 inclusive

The engine driven pneumatic pumps normally apply vacuum to the deicer boots and instruments, while the pressure control valves in the engine nacelles relieves all of the pressure produced by the pumps. Through the actuation of the control switch, deicer operation is started. Electrical power is supplied to the solenoids of the control valves. When energized the control valves regulate the pneumatic pump output air pressure to the deicer inflation pressure. After the required time and/or pressure is obtained electrical power is shut-off and pressure within the deicer system is released through an integral pressure relief section of the system and vacuum is reapplied to the deicer boots to hold them down.

14-66. **SYSTEM TROUBLESHOOTING.** In the utilization of the troubleshooting charts at the end of these instructions, it must be assumed that the engine driven combination pressure-vacuum pumps and the airplane electrical system are operational. It is further assumed that the deicer system installation was made in an approved manner.

14-67. **SYSTEM CHECKOUT.**

14-68. **ELECTRICAL TEST.**

- a. With engines off, turn airplane battery switch to the ON position.
- b. System Indicator Light: Press the indicator light to check light circuit and bulb. If light does not function:
 1. Reset circuit breaker and recheck.
 2. Test or replace the bulb.
 3. Check the circuit from the power source through the circuit breaker to the light to ground.
- c. Timer: Turn deicer system switch to the ON position. The timer should begin to operate immediately. Turn the system switch to OFF position. The timer should immediately re-cycle to the start position as evidenced by a brief timer "chatter."
- d. Time Modules: Turn system switch ON. The system should begin to operate immediately. System operation should continue for six seconds and then automatically turn off. If timer or timer module do not function:
 1. Reset circuit breaker and recheck.
 2. Check circuit from power source, through circuit breaker, to system switch, to timer or time module, to ground.
 3. Replace timer or time module.
- e. Control Valves and Exhaust Valve: Check both control valves; one in each nacelle and the exhaust valve in the fuselage by turning the system switch ON. The solenoids should be actuated immediately for six seconds, as evidenced by an audible "click" that can be felt if a hand is placed on the solenoid. If the valve does not function make the following checks:
 1. Unplug the electrical connector at the solenoid. Attach a test light or other suitable test equipment to the connector and re-actuate the system switch. If the test equipment does not indicate a complete circuit:
 - (a) Check circuit from timer or time module, to the solenoid connector, to ground.
 - (b) Replace timer or time module.

2. Use an ohmmeter to check the solenoid for an open circuit. If the solenoid circuit is open, replace the control valve.
3. Remove the solenoid safety wire and unscrew the solenoid.

CAUTION

Do not lose steel hex actuator pin or valve poppet.

Re-attach the connector to the solenoid; insert the hex actuator pin into the solenoid and re-actuate the system switch. If the pin is not ejected from the solenoid, replace the control valve.

f. Pressure Switch: With deicers pressurized to 12 psig or above (for procedure, see Air Leakage Test), pressure switch should close circuit to indicator light. If indicator light does not function:

1. Reset circuit breaker and recheck.
2. Check circuit from power source through circuit breaker, to indicator lamp, to pressure switch, to ground.
3. Disconnect and remove pressure switch. Check for plugged line or switch.
4. Replace pressure switch.

14-69. VACUUM REGULATOR ADJUSTMENT. The vacuum regulators must be adjusted to provide adequate vacuum for the airplane instruments. (Refer to Instruments, Section X for the proper procedure.)

14-70. COMPONENT MAINTENANCE AND REPLACEMENT.

14-71. AIR FILTER. Examine filter discs every 100 hours of engine operation and clean if oil has accumulated in housing. As cleaning agent, use a commercial hydrocarbon type solvent such as naphtha, petroleum ether or gasoline. Kerosene type distillates should be avoided. If desirable to replace filter discs, the part numbers are: Air Maze Corporation (Air Maze Division - North American Rockwell Corporation, Cleveland 20, Ohio (H9S888-36 (4 required) and H9S888-26 (5 required).

14-72. CONTROL VALVES. On early Deicing System installations wet vacuum pumps were used and this required periodic inspection of control valves after every 100 hours of engine operation. The valve poppet and internal lining of the control valve can become coated with a film of dried oil causing the valve to stick. To clean, remove the safety wire and unscrew the solenoid. To determine if the valve poppet is sticking, perform the electrical test. If the solenoid checks satisfactorily, remove the valve poppet and clean the control valve bore and poppet. To clean:

- a. Remove safety wire and electrical connector. Unscrew solenoid.

CAUTION

Do not lose steel hex actuator pin.

- b. Remove valve poppet. It may be necessary to apply slim nose pliers to pin projection to pull poppet from valve.
- c. Thoroughly clean valve bore and poppet with commercial hydrocarbon type solvent.
- d. Reassemble valve and re-safety wire solenoid.

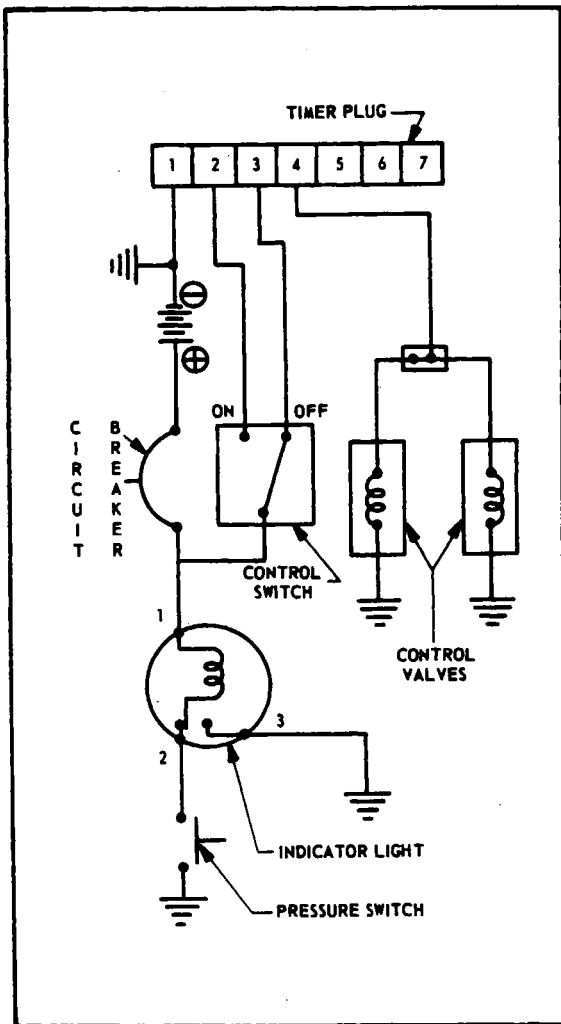

Figure 14-34. 28-Volt DC System
3D1472 Timer

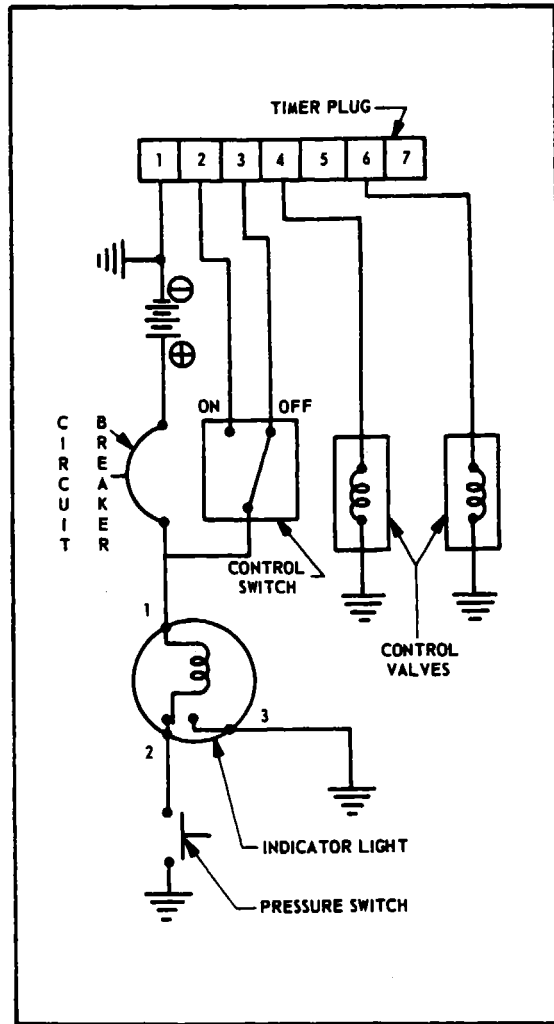

Figure 14-35. 14-Volt DC System
3D1740 Timer

PIPER AZTEC SERVICE MANUAL

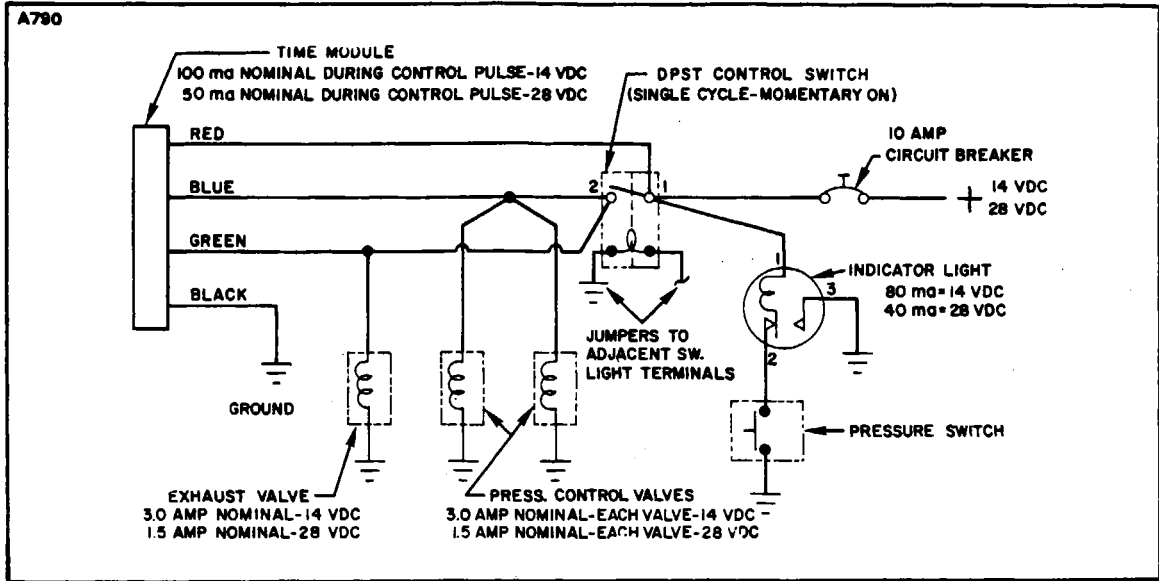

Figure 14-36. Pneumatic Deicer System Schematic (Using Time Module)

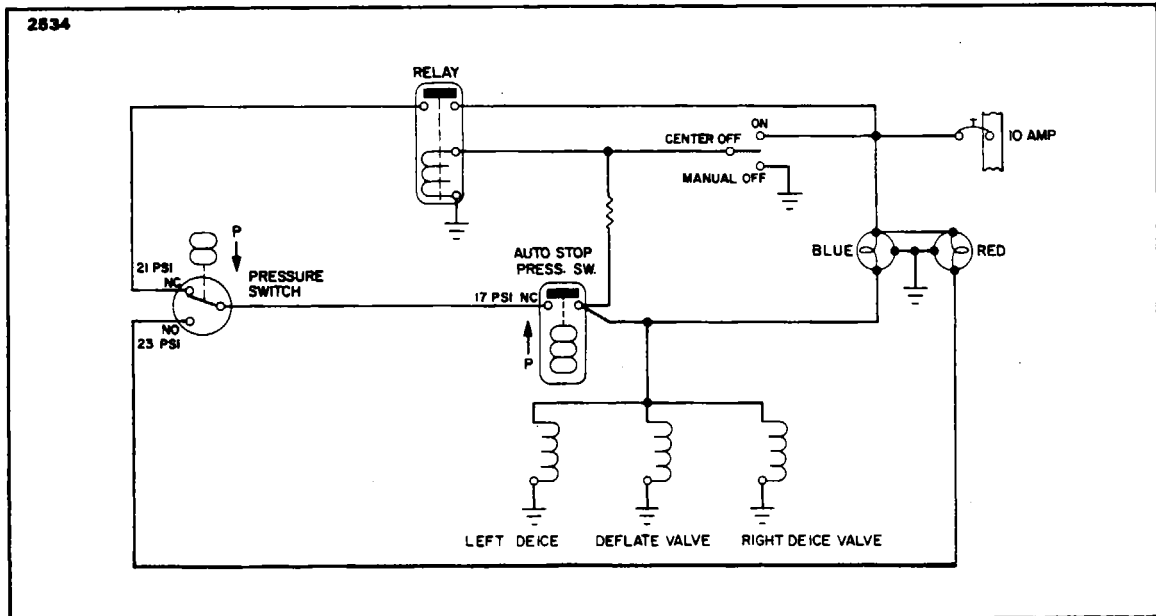

Figure 14-37. Pneumatic Deicer System Schematic (Airborne System)

PIPER AZTEC SERVICE MANUAL

14-73. **TIMER OR TIME MODULE.** No field maintenance is recommended. See Parts Catalog for replacement or vendor for repairs.

14-74. **SHUTTLE VALVE.** No field maintenance is recommended or authorized. For repair or replacement, contact your B.F. Goodrich dealer or distributor.

14-75. **REPLACEMENT.** No component maintenance other than that described in this manual is recommended.

14-76. **INSPECTION (PREFLIGHT).** Prior to the first flight each day, the deicer boots and the operating pressure shall be checked as follows:

a. Visually examine the surface of each boot carefully for tears, bruises, holes, loose patches, and clamps, and similar conditions which might result in further damage during flight.

b. Repair any such damage before takeoff is made.

c. Operate the engines at normal cruising RPM. Turn on the deicing system. Check the instrument suction should either side of the system fail, a small red button will appear at the corresponding side of the gauge face.

d. Observe the operation of the deicers carefully for evidence of malfunctioning. Look for tubes which leak or fail to inflate and deflate properly. All defects should be corrected before takeoff is made.

14-77. **INSPECTION (POST FLIGHT).** After the last flight each day, examine the boots for accumulation of oil, gasoline or other injurious substances. Particular attention should be given to empennage boots and to the inboard wing boots, since these are most likely to catch oil thrown by the engines. Clean off all such accumulations as soon as possible.

14-78. **INSPECTION (100 HOURS).** At each 100-hour inspection of the airplane, inspect and operate the deicer boots. Make checks as follows:

a. Carefully inspect the deicer for evidence of damage or deterioration and repair or replace damaged boots.

b. Resurface boots which show signs of considerable wear or deterioration.

c. Inspect all hose connections which form a part of the pneumatic deicing system. Replace deteriorated sections on non-kink hose.

d. Check operation of boots. Observe all standard safety precautions while operating the engines and system.

e. If new or replacement boots have been installed, check the tube inflation to make sure that the air connection stems have been properly connected.

f. On early systems using wet pneumatic pumps, disconnect all drain lines in the system and check for proper drainage.

PIPER AZTEC SERVICE MANUAL

CAUTION

Oil which reaches the deicers will cause rapid deterioration of the rubber. In cold weather, extreme care must be taken to see that engine oil does not collect in critical parts of the system and congeal. Congealed oil will cause sticking of control valves and distributor valve. If sticking of these parts is encountered, remove from the airplane, clean out, and replace.

- g. Check the ON-OFF control switch for freedom of action.
- h. Clean or replace the air filters.

NOTE

This operation may be omitted if boots were installed on the airplane subsequent to the last previous 100-hour inspection. On the other hand, if operations are being conducted under cold weather conditions below 10°F (-12°C), the filters should be cleaned out at each 100-hour inspection, or more often if difficulties are encountered with valves sticking due to congealed oil.

TABLE XIV-II. OPERATING PRESSURES

Recommended Operating Pressure PSIG	Test Pressure In PSIG	
	MIN.	MAX.
Early B. F. Goodrich 18	16	20
Later B. F. Goodrich 15	13	17
Airborne 17	22	25

14-79. INSPECTION (500 HOURS) AND PRESSURE TEST. A thorough inspection of the complete system including the 100 hour inspection and a functional inspection should be made at every 500 hours of engine operation. The following procedure has been divided into two parts to cover two different system installations. The first part will pertain to B.F. Goodrich systems while the second part pertains to Airborne system.

Part I. Goodrich:

- a. To permit ground checking the system without operating the engines, the following procedure should be used in conjunction with recommended operating pressures given in Table XIV-II.

- b. Refer to Table XIV-II for operating pressures required for system operation.
- c. Using a source of filtered shop air with a testing rig consisting of an adjustable regulator, pressure gauge and shut-off valve connect the shut-off valve so as to trap air in the deicer system.
- d. On Goodrich systems per Figure 14-32 disconnect the hose from the firewall bulkhead fitting (pump side) and attach the test rig to this port. Manually depress the solenoid plunger pin in the exhaust valve (if installed) and pressure control valves in the nacelle where the test rig is installed. Apply 15 psig to the system, and using the shut-off valve, trap this pressure in this portion of the system. A soap solution may be used to check for leaks. A pressure drop should not exceed 3 psig per minute. On Goodrich systems per Figures 14-30 and 14-31 cap the overboard port of one of the control valves. Connect a source of clean air to the inlet port of the control valve. Apply 18 psig to the system and by using the shut-off valve, trap the pressure in the deicer system. Observe the system for leakage. The leakage rate should not exceed a pressure drop of 3 psig per minute.
- e. With the battery switch in the ON position, check the pressure switch operation with the system under pressure, the indicator light should glow.
- f. With the battery switch ON and the deicer control switch OFF, press the indicator light to check the circuit and light bulb. If the indicator light does not function, check and reset the circuit breaker, a short circuit may exist. Refer to wiring schematic.
- g. Remove the test rig, lubricate the threads, replace and tighten items dismantled.
- h. On Goodrich systems referenced in Figure 14-32 an actual operating pressure test should be performed in the following manner:
 - 1. Move airplane to a clear runup area where prop blast will not disturb anything.
 - 2. Insert a tee connector into one of the lines which extends from the pressure switch fitting to either wing boot. Connect a pressure gauge (0-30 psig range) to the tee to monitor system pressure.
 - 3. Start and permit one engine to reach normal operating temperature. With the engine operating at approximately 2200 RPM, actuate the deicer control switch. Observe the pressure gauge; pressure should reach approximately 17 psig.
 - 4. Repeat step 3 with the opposite engine in operation.

CAUTION

Be sure the aircraft does not move when performing this ground test with both engines operating at high RPM.

- 5. Repeat step 3 with both engines operating at 2500 RPM.
- 6. With both engines operating at approximately 2500 RPM, actuate the deicer control switch. Pressure should reach approximately 20 psig.

NOTE

The maximum pressure reading should not be less than 16 psig with a single engine operating at 2200 RPM or greater than 21 psig with both engines operating at 2500 RPM. The pressure control valves can be adjusted to provide operating pressures within these limits. Refer to paragraph 14-80.

PIPER AZTEC SERVICE MANUAL

i. On Goodrich systems referenced in Figure 14-30 and Figure 14-31 an operating test and time cycle check should be performed in the following manner:

1. System operating test.
 - (a) With the engine running at cruise speed, move deicer control switch to ON position and observe deicer operation. System is satisfactory if the indicator light glows within 4.0 seconds after switching.
 - (b) Repeat procedure for other engine.
2. Time cycle check.
 - (a) With the engines running at minimum cruise speed, move deicer control switch to ON position and note time. With switch ON, reduce engine speed to normal idle and hold for approximately two and one-half minutes. At the end of this interval, increase engine speed to minimum cruise speed and observe deicers for inflation.
 - (b) Elapsed time from inflation-to-inflation should be approximately three minutes.

Part II. Airborne:

- a. To permit ground checking the system without operating the engines the following procedure should be used.
 - b. Disconnect the .750 inch hose to the inlet of the deicer control valves and connect a source of filtered shop air which is regulated at 25 psig. This hookup may be done to both valves simultaneously or one side at a time to check each half of the system separately.

CAUTION

Before turning on the air, disconnect and plug the .375 inch vacuum hold down source line where it connects into the suction side of the system to prevent possible air flow backwards through the gyros.

- c. Temporarily install a jumper wire on each of the two pressure switches located on the cross fitting within the fuselage. On the pressure switch with the two terminals, place the jumper wire on both terminals. On the pressure switch with three terminals, place the jumper wire on the terminals marked "C" and "NC."
- d. Turn on the air supply and energize the solenoid valves. The boots will inflate and the blue and red panel lights will come on and the system can be checked for leaks.

CAUTION

To prevent damage to the solenoid valves, do NOT leave them energized for more than two minutes continuously.

- e. Move the toggle switch to the "MANUAL DEFLATE" position and the boots will deflate.
- f. Remove the jumper wire shorting out the normally closed and common contacts on the pressure switch containing three terminals.
- g. Reactuate the toggle switch to the INFLATE position. The boots will inflate, the blue light will come ON and the boots should deflate automatically.

PIPER AZTEC SERVICE MANUAL

h. Now remove the jumper wire on the other pressure switch and reinflate the boots, they should automatically deflate as stated in step g.

i. An actual operating pressure test should be performed in the following manner:

1. Move the airplane to a clear runup area where prop blast will not disturb anything.

2. Check system operation on each engine individually and then with both engines operating.

3. A normal inflation cycle should last three to six seconds with engines operating at minimum cruise RPM before automatic deflation. Any radical departure from this could indicate a system leak. Refer to Table XIV-III for Troubleshooting Chart.

14-80. PRESSURE CONTROL VALVES ADJUSTMENTS. (Goodrich Systems per Figure 14-32.)

a. To increase the high pressure setting hold the locknut on top of the solenoid push rod with a wrench and with a screwdriver, turn the push rod clockwise until the desired setting is obtained.

NOTE

Directions clockwise and counterclockwise assumes the viewer is looking down on the top of the solenoid.

b. To lower the high pressure setting hold the locknut on top of the solenoid push rod and turn the push rod counterclockwise until the desired setting is obtained.

14-81. HIGH PRESSURE DEICER BOOTS.

14-82. DESCRIPTION. A high pressure deicer boot is essentially a fabric reinforced rubber sheet, containing built-in inflation tubes, that is attached to the leading edge of the surface to be protected by means of a cement.

There is an air connection on the backside of the deicer, called an "air connection stem." Each stem projects from the underside of the boot into the leading edge, through a round hole provided in the metal skin for connection to the air supply system.

Air pressure from engine driven pumps is supplied to the inflatable tubes by a suitable pneumatic system.

The deicer outer layer is made of conductive neoprene to allow static electricity to be dissipated. These charges, if allowed to accumulate, would eventually discharge through the boot to the metal skin beneath, causing static interference with the radio sending and receiving sets and possible punctures in the rubber. Also, such static charges would constitute a temporary fire hazard after each flight.

Deicers have spanwise inflatable tubes, only one inflation port and all tubes are inflated simultaneously. Boots are lightweight construction designed for lightweight airplanes.

14-83. **REMOVAL.** When necessary to remove the pneumatic deicer, it is recommended that an approved installation station accomplish this operation.

Should it be necessary to remove any portion of the pneumatic deicer, the following steps should be used:

a. Obtain a sharp, pointed non-metallic wedge several inches wide. A hardwood wedge would be suitable. Also, obtain a supply of Methylethylketone (MEK).

b. Start at a deicer corner at an upper edge and with the wedge, work up the deicer, using MEK in combination with the wedge to avoid removing the rubber coating from the back of the deicer. Using a small, oil type squirt can will help direct the flow of MEK and help avoid damaging the paint.

CAUTION

Be extremely careful when removing boot so as not to exert force while pulling or lifting, as this could result in tearing boot.

c. Using the wedge and MEK, continue working up the deicer skin until the deicer has been removed to the desired point.

d. Clean the existing portions of the surface and deicer, thoroughly removing all cement. Use MEK to do this.

14-84. PRE-INSTALLATION REQUIREMENTS

14-85. **MATERIALS.** The following materials are required:

EC-1300L and/or EC-1403 cement, Minnesota Mining & Manufacturing Co. FSN 8040-628-4199 and/or 8040-514-1880.

Methylethylketone (MEK) Federal Specification TT-M-261, or Acetone, Federal Specification O-A-51.

Tackifying solvent, Toluol or MEK (See note)

Clean, lint-free cleaning cloths

Several empty tin cans

3 inch paint brushes

2 inch rubber hand rollers

1/4 inch metal hand stitcher roller

Carpenter's chalk line

1 inch masking tape

Steel measuring tape

Sharp knives

Fine sharpening stone

Sealing compound EC-801, Minnesota Mining & Manufacturing Co.

Cement A-56-B, B. F. Goodrich Co.

NOTE

MEK may be used instead of Toluol to re-activate cement for installation. However, tests show that MEK causes very rapid drying and provides only 10 seconds working time for deicer application compared with 40 seconds for Toluol.

14-86. PREPARATION OF LEADING EDGES.

- a. With 1 inch masking tape, mask off leading edge boot area, allowing 1/2 inch margin. Take care to mask accurately, thus eliminating the need for cleaning off excess cement later.
- b. Clean the metal surfaces thoroughly at least twice with MEK or acetone. For final cleaning, wipe the solvent film off quickly with a clean dry cloth before it has time to dry.
- c. Fill gaps of skin splices that lead under deicers with sealing compound EC-801.

14-87. PREPARATION OF DEICER. Moisten a clean cloth with MEK or acetone and carefully clean the rough, back surface of the boot at least twice. Change cloths frequently to avoid recontamination of the cleaned areas.

14-88. INSTALLATION OF DEICER.

WARNING

The cements and solvents used for installation are flammable and their fumes slightly toxic. Therefore, all work should be done in a well-ventilated area away from any sparks or flames. (Use a solvent resistant type gloves is recommended.)

NOTE

Do not inflate deicers within 12 hours of installation or until adhesion strength of 10 pounds is obtained.

a. Thoroughly mix EC-1300L cement before using. Apply one even brush coat to the cleaned back surface of the boot and to the cleaned metal surface. Allow the cement to air dry for a minimum of one hour. Apply a second coat to both surfaces and allow to air dry a minimum of one hour. Ambient temperature for installation should be held between 40 and 110 degrees F. However, longer drying time of the cement coats may be required as the humidity approaches 99%. Deicer and leading edge may be cemented for a maximum of 48 hours before actual installation.

b. Using a clean, lint-free cloth moistened with Toluol, re-activate the cement on the leading edge surface and boot in spanwise strips approximately 6 inches wide. Avoid excessive rubbing of the cement which could remove the cement from the surface. Obtain sufficient personnel to hold boot steady during installation. (Limit handling cemented side of boot with fingers.) Roll the deicer firmly against the wing leading edge, being careful not to trap any air under the deicer. Always roll parallel to the inflatable tubes.

PIPER AZTEC SERVICE MANUAL

- c. If the deicer should attach "off course," use MEK to remove and reposition properly. Avoid twisting or sharp bending of the deicer.
- d. Rubber roll, applying pressure over entire surface of the deicer. All rolling should be done parallel to the inflatable tubes. Roll trailing edges with a narrow stitcher roller.
- e. After the cement has dried, remove all masking tapes and clean surfaces with Toluol being careful not to let Toluol run under edge of cemented down deicer.
- f. Apply a brush coat of A-56-B cement to EC-801 seams and along trailing edges of deicer to form a neat straight line being sure that the conductive coating (A-56-B) is continuous from the deicer surface to the wing surface.

14-89. SERVICE LIFE OF DEICERS. An average service life of approximately 30 months can be expected, if the following precautions are observed.

14-90. MAINTENANCE.

1. Keep pneumatic deicers free of oil, gasoline, paint remover, solvents, and other injurious substances.
2. Do not rest ladders or work stands against leading edges having deicers installed. Wrap padding around those portions of work stands which could come in contact with deicers.
3. When refueling or servicing aircraft with oil, do not drag the servicing hose over the deicers. Use suitable padding for protection.
4. Do not walk on the deicer boots. Also, do not lay tools or other objects on them.
5. Exercise care at all times to prevent the boots from being subjected to abuse.
6. Clean deicers when the airplane is washed with a mild soap and water solution. In cold weather, wash the boots with the airplane inside a warm hangar if possible. If the cleaning is to be done outdoors, heat the soap and water solution before taking it out to the airplane. If difficulty is encountered with the water freezing on the boots, direct a blast of warm air along the region being cleaned, using a portable type ground heater. As alternates, use benzol or non-leaded gasoline. Moisten the cleaning cloth in the solvent, scrub lightly, and then, with a clean, dry cloth, wipe dry so that the cleaner does not have time to soak into the rubber. Petroleum products such as these are injurious to rubber, and therefore should be used sparingly.
7. Prior to the first flight each day, the deicers should be checked as follows:
Visually examine the surface of each boot carefully for tears, holes, bruises, loose patches and similar conditions which might result in further damage during flight, and repair any such damage before takeoff per instructions included in Iceguard Repair Kit 700.

If a replacement is not available, or repair is impossible, remove both the damaged and the corresponding deicer on the opposite side of the airplane before attempting flight. (See paragraph 14-83 for removal instructions.)

8. After the last flight each day, examine the boots for accumulation of oil, gasoline, or other injurious substances, and clean off as soon as possible.

14-91. ICEX APPLICATION. B.F. Goodrich Icx is silicone base material specifically compounded to lower the strength of adhesion between ice and the rubber surfaces of airplane deicers. Icx will not harm rubber, and offers added ozone protection.

Properly applied and renewed at recommended intervals, Icx provides a smooth, polished film that evens out the microscopic irregularities on the surface of rubber parts. Ice formations have less chance to cling. Ice is removed faster and cleaner when deicers are operated.

PIPER AZTEC SERVICE MANUAL

It should be emphasized that Icx is not a cure-all for icing problems. Icx will not prevent or remove ice formations. Its only function is to keep ice from initially getting a strong foot-hold, thus making removal easier.

One 16 oz. pressurized can of Icx will cover deicer surfaces of the average light twin-engine plane approximately three times. It is also available in quart cans (unpressurized).

Before applying Icx, thoroughly clean deicer or other rubber surfaces with a rag dampened with non-leaded gasoline. Follow by a scrub wash of mild soap and water. Allow time for surfaces to dry.

Shake the Icx can well. Hold the nozzle approximately 12 inches from the surface and spray. Apply sparingly. If the application is too heavy it results in a sticky surface which is very undesirable because it will pick up runway dust and prevent best ice removing efficiency.

Due to the natural abrasive effects on leading edges of deicers, propellers and abrasion boots during flight, reapply Icx every 150 flight hours on wings and empennage deicers.

14-92. REPAIR. Deicer repairs are classified as cold (temporary), made on the boot installed on the airplane, and vulcanized, made on the demounted boot in the shop.

14-93. COLD REPAIR. The materials and supplies for making cold repairs are listed as follows:

Material and Supplies for Cold Repair

Part No.	Quantity	Description
74-451-C (FSNI650-856-7939)	1	Cold Patch Repair Kit (B. F. Goodrich Co.)
74-451-11	1/2 pt. can	A-56-B Conductive cement
74-451-16	30 pcs.	Small oval patch 1-1/4 x 2-1/2 in.
74-451-17	30 pcs.	Medium oval patch 2-1/2 x 5 inch.
74-451-18	10 pcs.	Large oval patch 5 x 10 in.
74-451-19	3 pcs.	Patch 5 x 19 inch.
74-451-20	(2) 1/2 pt.	No. 4 cement ⁽¹⁾ (patching only)
74-451-70	2	Cement brush 1/2 in.
74-451-73	1	1/8 in. Steel stitcher
74-451-75	6	Emery buffing sticks
74-451-87	1	Buffing shield

⁽¹⁾ This cement will give best results with the patches in this kit.

PIPER AZTEC SERVICE MANUAL

Material and Supplies for Cold Repair (cont.)

Part No.	Quantity	Description
The following items may be procured from the B. F. Goodrich Company, Akron, Ohio, or other manufacturer, as required.		
74-451-23 74-451-24 (FSN8040-628-4199 and/ or FSN8040-514-1880) 74-451-74	4 ft. long x 8 in. wide 1 quart 1	Neoprene surface ply EC-1403 cement and/or EC-1300 L 2-1/2 in. sponge rubber roller
Minnesota Mining and Manufacturing Company, Adhesives Division, 411 Piquette Avenue, Detroit, Michigan.		
The following materials may be obtained from local supply:		
	As required Rolls 1 6 ft. long 1 As required As required	Toluol Clean, lint-free cloths (preferably cheese cloth) 1 in. masking tape Sharp knife Steel measuring tape Fine sharpening stone Steel wood pads Hypodermic needles (22 gauge or smaller)
Methylethylketone (MEK) can be used instead of Toluol, however, MEK causes very rapid drying and provides only 10 seconds working time compared with 40 seconds for Toluol.		

14-96. **SCUFF DAMAGE.** This type of damage will be most commonly encountered, and, fortunately, it is not necessary in most cases to make a repair. On those rare occasions when the scuff is severe and has caused the removal of the entire thickness of surface ply in spots (the brown natural rubber underneath is exposed), repair the damage, using parts No. 74-451-16, 74-451-17, 74-451-18 or 74-451-23, and proceed as follows:

- a. Clean the area around the damage with a cloth dampened slightly with solvent.
- b. Buff the area around the damage with steel wool so that it is moderately but completely roughened.
- c. Wipe the buffed area with a clean cloth slightly dampened with solvent to remove all loose particles.
- d. Select a patch of ample size to cover the damaged area.
- e. Apply one even thorough coat of cement, Part No. 74-451-20, to the patch and the corresponding damaged area.
- f. Allow cement to set a couple of minutes until tacky.
- g. Apply the patch to the De-Icer with an edge, or the center, adhering first. Work down the remainder of the patch carefully to avoid trapping air pockets. Thoroughly roll the patch with stitcher-roller, Part No. 74-451-73, and allow to set for ten to fifteen minutes.
- h. Wipe the patch and surrounding area from the center outward with a cloth slightly dampened with solvent.
- i. Apply one light coat of A-56-B conductive cement, Part No. 74-451-11, to the patched area.
- j. Satisfactory adhesion of patch to De-Icer will be reached in four hours. De-Icer may be inflated for checking repair in a minimum of 20 minutes.

14-97. **TUBE AREA DAMAGE.** Repair cuts, tears or ruptures to the tube area with fabric reinforced patches, Part No. 74-451-16, 74-451-17, 74-451-18 or 74-451-19, depending on size of damage.

- a. Select a patch of ample size to cover the damage and to extend to at least 5/8 inch beyond the ends and edges of the cut or tear. If none of the patches is of proper size, cut one to the size desired from one of the larger patches. If this is done, bevel the edges by cutting with the shears at an angle.

NOTE

These patches are manufactured so that they will stretch in one direction only. Be sure to cut and apply the patch selected so that stretch is in the widthwise direction of the inflatable tubes.

- b. Proceed with repair in the manner outlined in paragraph 14-96.
- c. Buff the area around the damage with buffing stick, Part No. 74-451-75 so that the surface is thoroughly roughened.
- d. Apply the patch to the De-Icer with the stretch in the widthwise direction of the inflatable tubes, sticking edge of patch in place, working remainder down with slight pulling action so the injury is closed. Do not trap air between patch and De-Icer surface.

14-98. LOOSE SURFACE PLY IN DEAD AREA (NON-INFLATABLE AREA.) Peel and trim the loose surface ply to the point where the adhesion of surface ply to the De-Icer is good.

- a. Scrub (roughen) area in which surface ply is removed with steel wool, scrubbing motion must be parallel to cut edge of surface ply to prevent loosening it.
- b. Scrub with steel wool and Toluol directly over all edges, but parallel to edges of surface ply to taper them down to the tan rubber ply.
- c. Cut a piece of surface ply material, Part No. 74-451-23, to cover the damaged area and extend at least one inch beyond in all directions.
- d. Mask off the damaged boot area 1/2 inch larger in length and width than the size of surface ply.
- e. Apply one coat of cement, Part No. 74-451-11, to damaged area and one coat to surface ply. Allow cement to set until tacky.
- f. Roll the surface ply to the De-Icer with two inch rubber roller, Part No. 74-451-74. Roll edges with stitcher-roller, Part No. 74-451-73.
- g. Apply just enough tension on the surface ply when rolling to prevent wrinkling.
- h. Be careful to prevent trapping air. If air blisters appear after surface ply is applied, remove them with a hypodermic needle.
- i. Clean excess cement from De-Icer with solvent.

14-99. LOOSE SURFACE PLY IN TUBE AREA. Loose surface ply in tube area is usually an indication of the De-Icer starting to flex fail. This type of failure is more easily detected in the form of a blister under the surface ply when De-Icer is pressurized. If this type of damage (or void) is detected while still a small blister (about 1/4 or 3/8 inch diameter) and patched immediately, the service life of the De-Icer will be appreciably extended.

- a. Apply repair patch as outlined in paragraph 14-97.

14-100. DAMAGE TO FABRIC BACK PLY OF HIGH PRESSURE DE-ICER DURING REMOVAL. If cement has pulled loose from the wing skin and adhered to the back surface of the De-Icer, remove it with steel wool and MEK.

a. In those spots where the coating has pulled off the fabric, leaving bare fabric exposed, apply at least two additional coats of cement, Part No. 74-451-24. Allow each coat to dry thoroughly.

14-101. VULCANIZED REPAIR. It is recommended that vulcanized repairs be made by an approved De-Icer Installation Station.

PIPER AZTEC SERVICE MANUAL

TABLE XIV-III. PNEUMATIC DEICER PUMP SYSTEM TROUBLESHOOTING
(B. F. GOODRICH SYSTEM)

Trouble	Cause	Remedy
<p>De-Icers do not inflate - both engines operating at minimum cruise RPM or either engine at maximum ground RPM. (for 8 seconds.)</p>	<p>Open circuit breaker.</p> <p>System connection loose or wire broken.</p> <p>Timer not functioning.</p> <p>Control valves not functioning.</p> <p>Piping lines blocked or not connected.</p>	<p>Push circuit breaker to reset.</p> <p>Tighten or repair as required.</p> <p>See Electrical Test - through Timer.</p> <p>See Electrical Test - through control valve. Valve poppet sticking; see Maintenance - control valve.</p> <p>See air leakage test. Blow out line and inspect connections.</p>
<p>De-Icers inflate slowly - both engines operating at minimum cruise RPM or either engine at maximum ground RPM (for 8 seconds.)</p>	<p>Piping lines partially blocked or not connected securely.</p> <p>Shuttle valve not functioning.</p> <p>Low air pump capacity.</p> <p>De-Icer puncture.</p>	<p>Inspect and blow out lines. See air leakage test.</p> <p>Check fitting in De-Icer port for proper installation.</p> <p>Check performance to manufacturer's specifications.</p> <p>Repair per specification or replace.</p>

PIPER AZTEC SERVICE MANUAL

TABLE XIV-III. PNEUMATIC DEICER SYSTEM TROUBLESHOOTING (cont.)
(B. F. GOODRICH SYSTEM)

Trouble	Cause	Remedy
De-Icers inflate - Indicator light does not function.	<p>Indicator lamp burned out.</p> <p>System pressure not being reached.</p> <p>Pressure switch not functioning.</p> <p>Wires loose or broken. Poor grounding of pressure switch.</p>	<p>Replace lamp.</p> <p>Check "De-Icers inflate slowly."</p> <p>See Electrical Test - Indicator Light and Pressure Switch.</p> <p>See Electrical Test - Indicator Light and Pressure Switch.</p>
De-Icers deflate slowly.	<p>Vacuum regulator set too low.</p> <p>Clogged air filters.</p> <p>Piping, lines partially blocked.</p> <p>Overboard line from control valve partially blocked.</p>	<p>Re-adjust vacuum regulator. See Vacuum Regulator Adjustment.</p> <p>Clean or replace filter. See Maintenance - Filter Element.</p> <p>Inspect and blow out lines.</p> <p>Inspect and blow out lines.</p>

PIPER AZTEC SERVICE MANUAL

TABLE XIV-III. TROUBLESHOOTING - PNEUMATIC DEICER
(AIRBORNE SYSTEM)

Trouble	Cause	Remedy
Slow boot inflation.	<p>Air lines blocked or disconnected.</p> <p>Low pneumatic pump capacity.</p> <p>One or more solenoid valves not functioning properly.</p> <p>Deicer boot punctured.</p>	<p>Check lines and repair.</p> <p>Check performance to manufacturers specifications.</p> <p>Replace solenoid valve as required.</p> <p>Repair per specifications or replace.</p>
Boots do not inflate.	<p>Faulty deflate valve.</p> <p>Two faulty deice control valves.</p> <p>Relay not functioning.</p> <p>Leak in system.</p> <p>Open circuit breaker.</p>	<p>Replace valve.</p> <p>Replace valves.</p> <p>Check wiring or replace relay.</p> <p>Repair leak</p> <p>Reset circuit breaker.</p>
Blue indicator light does not light on inflation.	<p>Lamp burned out.</p> <p>Loose wires.</p> <p>Faulty pressure switch.</p>	<p>Replace bulb.</p> <p>Repair wires.</p> <p>Short out N.C. switches separately to find bad one and replace.</p>

PIPER AZTEC SERVICE MANUAL

TABLE XIV-III. TROUBLESHOOTING - PNEUMATIC DEICER (cont.)
(AIRBORNE SYSTEM)

Trouble	Cause	Remedy
Slow deflation.	Low vacuum. Leak in system. Faulty deflate valve.	Readjust regulator. Repair leak. Replace valve.
Red indicator light does not light with both normally closed switches shorted out during ground testing.	Lamp burned out. Faulty pressure switch. Loose wires.	Replace bulb. Replace switch. Replace wires.
System will not automatically deflate.	Faulty pressure switch. Faulty relay. Defective switch.	Check and/or replace. Check wiring or replace relay. Check and/or replace.

14-102. PROPELLER SYNCHRONIZER. (Hushtrol System)

14-103. DESCRIPTION OF PROPELLER SYNCHRONIZER SYSTEM.

The system consists of two magnetic pickups, an electrical control chassis to monitor the system, a phase servo to regulate the slave propeller governor, and a control head in the cockpit along with the related wire harnesses.

The function of the propeller synchronizer system is to automatically match the propeller RPM of both engines within a preset range of RPM. This is accomplished by using the left engine as the master unit and the right engine as the slave unit. The right hand magnetos of each engine have magnetic pickups which feed electrical pulses into the electronic control chassis located on the right engine mount aft of the firewall. The control chassis detects any difference in the electrical pulses and in turn activates a servo assembly mounted on the right engine mount, which trims the right propeller governor, thus maintaining the same propeller RPM as the master left engine.

NOTE

The system will only maintain a synchronized condition as long as the RPM setting of the master engine is not changed from the time the system is activated. Should it be necessary to go beyond the limit of the system, the control head switch must be turned to the manual position which will allow the phase servo to center itself and be ready to synchronize the system when reactivated.

Normal governor operations are not changed, but the synchronizer will continuously monitor the propeller RPM and regulate the slave governor as required within the RPM range of the system as long as it is on. The limiting range of operation is built into the system to prevent the slave propeller governor from loosing more than a fixed amount of RPM in case the master engine propeller is feathered with the system in operation.

14-104. TROUBLESHOOTING. Troubles peculiar to this system are listed in Table XIV-IV along with their probable causes and suggested remedies. The following information will help locate system malfunction with the minimum amount of equipment.

14-105. FUNCTIONAL TEST. This test can be done on the ground with no special test equipment required. The following steps should be used:

- a. Start up both engines and run them at 2100 RPM to get both governors operating.
- b. Turn on the synchronizer system and allow the system to stabilize.
- c. With the synchronizer still on, shut down the master engine.
- d. Pull the synchronizer system circuit breaker off. This will keep the phase servo in whatever position it has moved to.
- e. Shut down the other engine and check the phase servo plunger - it should be fully retracted.

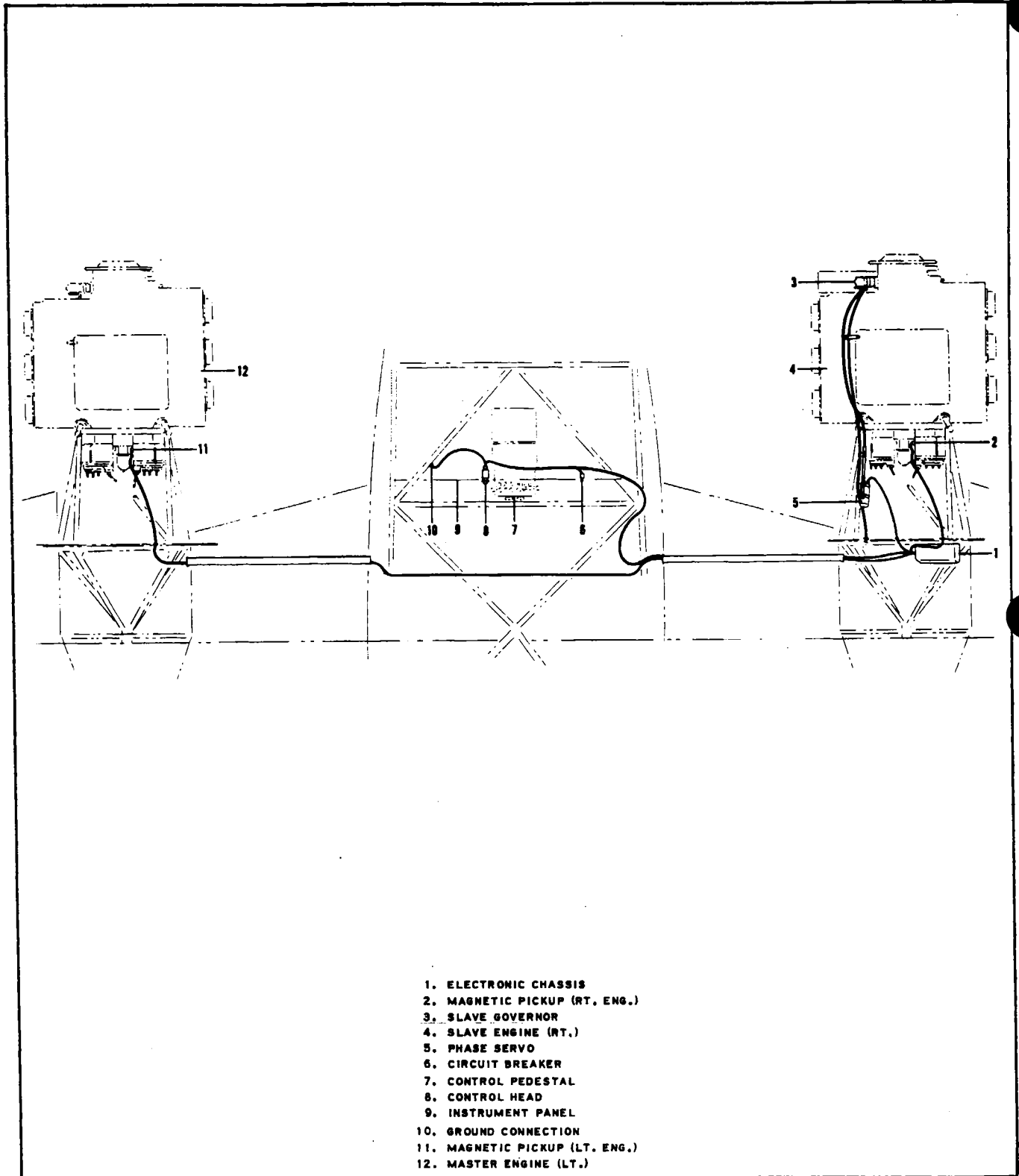

Figure 14-38. Propeller Synchronizer System Installation

- f. Repeat steps a. thru b. and now shut down the slave engine. Continue with step d.
- g. Shut down the master engine and check the phase servo plunger - it should be fully extended.
- h. If the above steps cannot be met the phase servo should be replaced.

14-106. **MAINTENANCE.** Little maintenance is required on this system apart from visual inspection at the time of regular airplane inspection. Ascertain that the electrical connections and all related components are securely attached.

14-107. **REMOVAL OF PHASE SERVO.**

- a. Remove the right engine cowling.
- b. Disconnect the electrical plug from the servo.
- c. Loosen the jam nut from the servo cable at the governor end.
- d. Loosen jam nut on cable adapter at the servo and disconnect the cable and adapter from the servo.
- e. Loosen the four screws which secure the servo in the clamp assembly and slide the servo out.

14-108. **INSTALLATION OF PHASE SERVO.**

- a. Place the servo into the clamp assembly, ascertain that the actuator end is forward the servo cable and adapter.
- b. Connect the adapter to the servo, but do not tighten the jam nut at this time.
- c. Connect the electrical plug to the servo.
- d. Adjust the servo in accordance with paragraph 14-109.
- e. Install the right engine cowling.

14-109. **ADJUSTMENT OF PHASE SERVO.** (Refer to Figure 14-40.)

- a. Ascertain that the servo is in its neutral position by momentarily turning the unit on to the manual position.
- b. Position the servo cable into the linkassembly and leave approximately .25 to .19 of an inch of threads exposed above the jam nut.
- c. Set both propeller pitch control levers to the high position.
- d. Hold the governor arm against the high RPM stop and move the servo in its bracket to align the right propeller control lever with the left lever.

NOTE

Increasing the distances between the servo and the control cable housing will move the propeller control lever forward, and decreasing this distance will move the lever aft. This can be accomplished by turning the adapter at the servo or by removing the servo cable from the governor control arm and turning the cable. The servo control cable must be removed at the governor to relieve any twist in the cable assembly.

e. Ascertain that the servo stays within the clamps of the mounting bracket during the adjustment of the propeller control lever. Tighten the clamps to secure the servo in place.

14-110. PROPELLER GOVERNOR ADJUSTMENT. For the synchronizer system to function properly the proper adjustment of the governor is necessary.

With each governor against the high RPM stop, the left hand engine (master) should show 2575 RPM and the right hand engine (slave) should show 2575+ RPM.

NOTE

The slave engine must always be at least 1 RPM more than the master engine for the propeller synchronizer to function properly.

Adjust the governor in accordance with instructions given in Section VIII. Set the slave engine governor approximately 25 RPM higher than the master engine. An incorrect setting of the governor will result in the slave engine searching for an impossible position. If the master engine is set faster than the slave engine when the governors are against the high RPM stops, and the control switch is turned from the manual to the Auto position, the servo will extend attempting to increase the slave engine RPM to match the master engine. But because of the slave engine high RPM stop it will force the propeller pitch control lever aft and will never achieve synchronization.

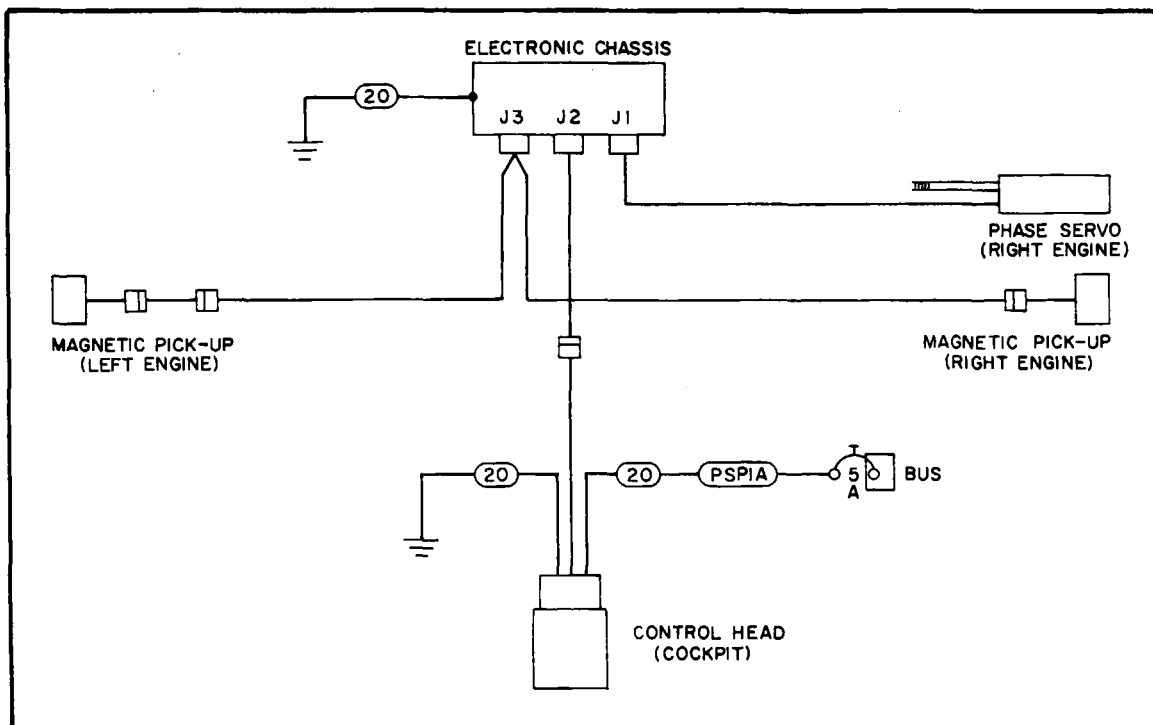

Figure 14-39. Synchronizer Schematic

14-111. REMOVAL OF ELECTRONIC CHASSIS.

- a. Remove the access panel on the top of the right engine nacelle.
- b. Disconnect the three electrical plugs at the electronic chassis.
- c. Loosen and remove the three locknuts and screws which secure the chassis to the engine mount.
- d. Remove the chassis from the airplane.

14-112. INSTALLATION OF ELECTRONIC CHASSIS.

- a. Position the electronic chassis into the nacelle and secure in place with three screws and locknuts.
- b. Connect the three electrical plugs to the chassis.
- c. Install the access panel to the top of the nacelle.

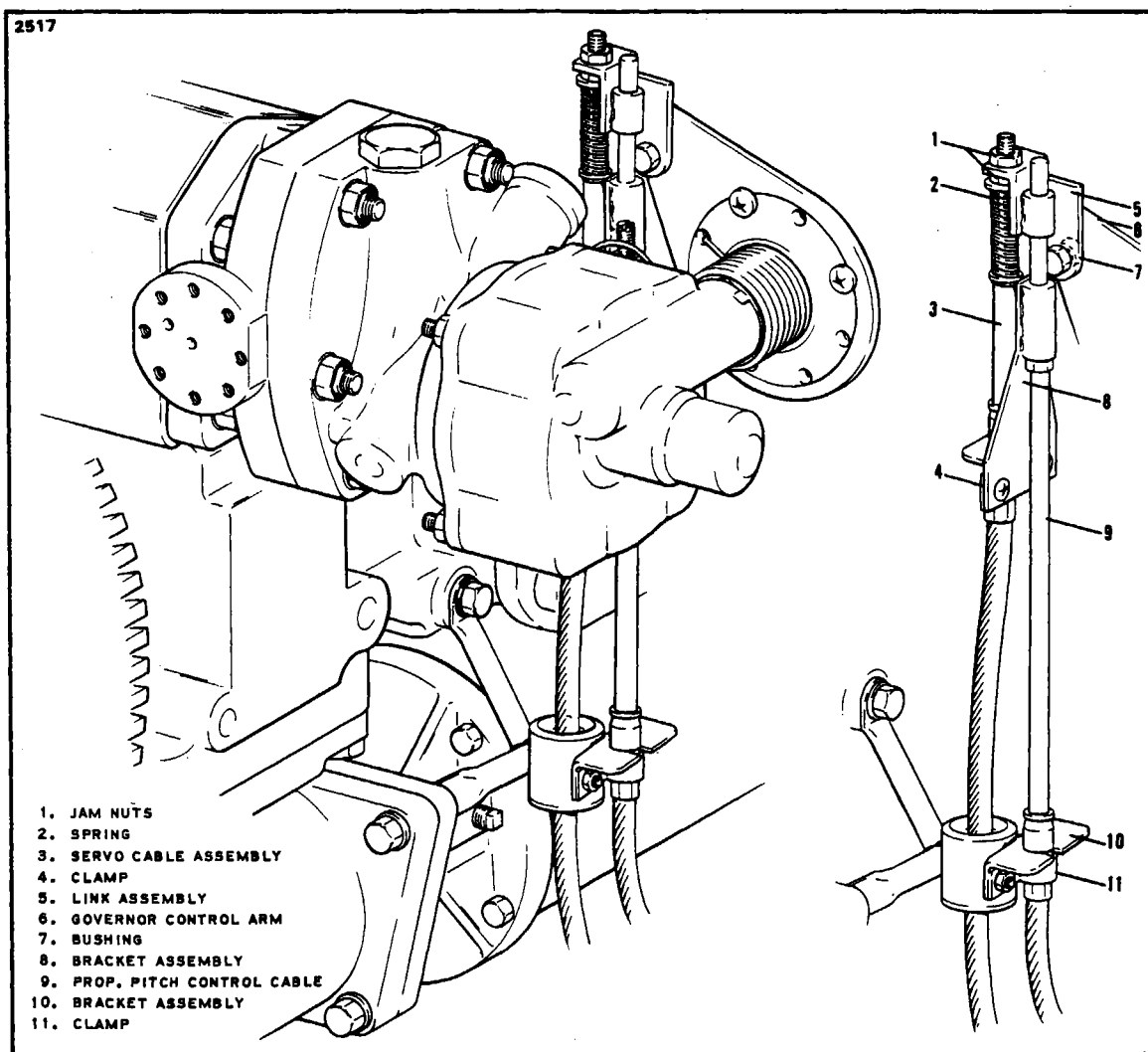

Figure 14-40. Mechanical Connections

14-113. TEST EQUIPMENT. A piece of test equipment can be fabricated to simulate engine running conditions so the system operation can be checked in the hangar without actually running the engines. A list of parts and a schematic are shown in Figure 14-41. The following steps will explain the use of this test box:

- a. Disconnect the magnetic pickup plug J-3 from the electronic chassis and connect the matching plug from the test box.
- b. Connect the test box AC plug to any available 115-volt AC power supply and set the master switch on the test box ON and both engine switches OFF.
- c. Turn the aircraft master switch ON, the synchronizer control to the AUTO position and ascertain that the synchronizer circuit breaker is IN.
- d. Set the right engine switch of the test box ON and the left engine switch OFF. The phase servo plunger should be fully retracted.
- e. Set the left engine switch of the test box ON and the right engine switch OFF. The phase servo plunger should be fully extended, approximately .50 of an inch.

NOTE

As each engine switch is actuated it will simulate engine running conditions and operate the phase servo accordingly. Operation may be slow, but the plunger should go to the full extreme of its travel.

f. With both engine switches of the test box ON, rotate the phase control slowly and observe the phase servo for a small amount of movement as it tries to change the phase of both engines.

g. If the phase servo does not perform as outlined, the servo, electronic chassis and control head should be returned for further test.

14-114. ELECTRIC WINDSHIELD ANTI-ICE.

14-115. DESCRIPTION. The electric windshield anti-ice consists of an electrically heated anti-ice panel installed in front of the pilot's windshield, a 15 amp circuit protector and a windshield heat on-off switch.

A field repair kit, No. 764-096, is available from Piper dealers for replacement of a defective windshield anti-ice panel connector plug.

PIPER AZTEC SERVICE MANUAL

PARTS LIST FOR SYNCHRONIZER TEST INSTRUMENT		
Amount	Part	Type
1	10 Volt AC Transformer	any AC
1	Switch	S-P-S-T
2	Switch	D-P-S-T
1	Socket	M53106A-14S-6P
1	Plug	115 Volt AC
Approx. 20 feet.	Cable, two conductor shielded - AN22 or larger.	

A787

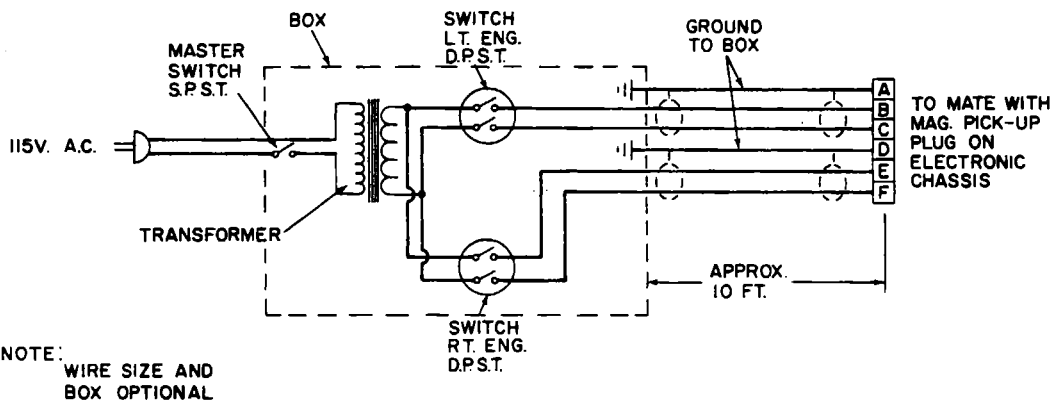

2516

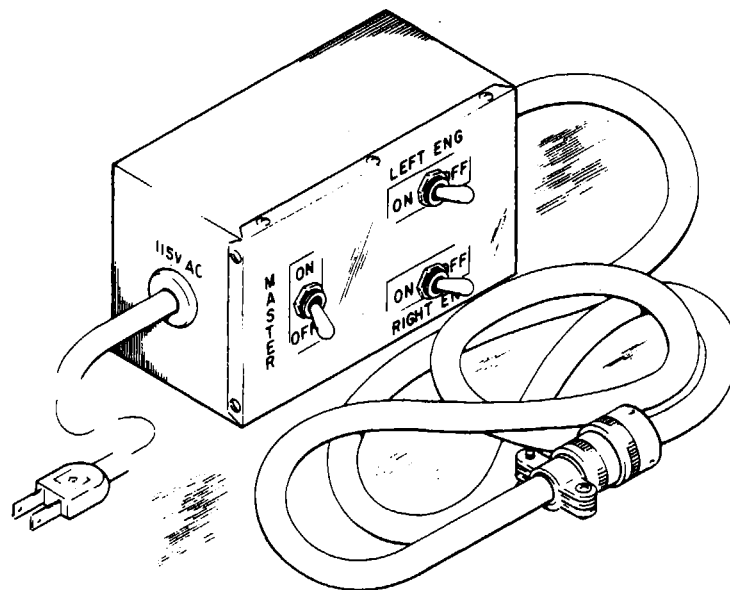

Figure 14-41. Fabricated Test Box

PIPER AZTEC SERVICE MANUAL

TABLE XIV-IV. TROUBLESHOOTING CHART (PROPELLER SYNCHRONIZER)

Trouble	Cause	Remedy
Synchronizer hunting.	Binding of the governor control arm, and/or cable assembly. Master governor speed is varying.	Correct any mechanical binding. Overhaul governors.
Synchronizer runs out of synchronization when turned on.	Intermittent shorts or opens in the pickup or its wiring.	Replace defective pickup.
Synchronizer will not center.	Defective pickup. Defective electronic component. Mechanically misrigged.	Replace. Replace. Rerig.
Lack of range.	Improper rigging. Trying to synchronize too close to a mechanical stop. Defective electronic component.	Rerig properly. Adjust prop control in cockpit to move speed control lever further away from stop. Replace

PIPER AZTEC SERVICE MANUAL

TABLE XIV-IV. TROUBLESHOOTING (PROPELLER SYNCHRONIZER) (cont.)

Trouble	Cause	Remedy
Synchronizer corrects in one direction only.	Defective electronic component.	Replace
	Mechanical binding in one direction.	Correct binding.
	Improper rigging.	Rerig.
Slow to syn-chronize and won't hold syn-chronization.	Defective electronic component.	Replace
	Excessive mechanical friction.	Current mechanical binding.
	Intermittent short in pickup or wiring.	Repair pickup lead or replace pickup.
	Defective electrical plug connector.	Replace plug connector.

14-116. ENGINE SYNCHROPHASER. (PA-23-250 (six place), Serial Nos. 27-3944 and up.)

14-117. DESCRIPTION OF SYNCHROPHASER SYSTEM. (Refer to Figure 14-42.)

This system consists of a pulse generator, a strobe sensor (replaced by another pulse generator in Serial Nos. 27-7854068 and up), a computer, and an electrical control solenoid.

The pulse generator, located on the master LEFT engine supplies timing information to the strobe sensor on the slave RIGHT engine. The resultant error signal, generated by the strobe sensor is fed to the computer that in turn drives the servo amplifiers. The output of the servo amplifiers controls the electrical solenoid on the slave engine governor. This control action keeps the slave engine in phase with the rotation of the master engine.

NOTE

Serial Nos. 27-7854068 and up have a second generator in lieu of the strobe sensor. The signals from both generators are supplied directly to the computer for comparison. The difference signal is amplified and fed to the governor solenoid to control the slave engine.

The pulse generator is mechanically driven by the camshaft of the master LEFT engine. One rotation of the camshaft constitutes one cycle of engine operation of a four stroke engine. This permits the pulse generator to be timed to any relationship to the firing order of the engine. The strobe sensor (another pulse generator on the later systems) is likewise driven by the camshaft on the slave engine. This gives a latitude of selection, permitting any selection of corresponding operation between master and slave engine.

The selector switch on the panel has two positions, manual or phase. In the manual position, engines and propellers are operated and controlled in the conventional manner. After manually synchronizing engines, the selector switch can be set to the phase position. This permits the synchrophaser to hold engines in RPM agreement and also in the preselected phase relationship.

14-118. SYSTEM OPERATING PROCEDURE. (PA-23-250 (six place), Serial Nos. 27-3944 and up.)

The selector switch should be in the manual position during engine start, taxi and warm-up. The switch may be turned to phase position after the take-off run has started, if desired.

NOTE

With full throttle and full RPM the governors should be set within the synchrophasing range, if not consult Section VIII or VIHA of this Service Manual for high RPM setting adjustment.

PIPER AZTEC SERVICE MANUAL

The propeller RPM should be manually adjusted as close to synchronization as possible for cruise, and the quadrant friction control set. Turn the switch to the phase position, if the unit does not synchronize the props, return the selector switch to manual. After 45 seconds adjust engine RPM manually to within 25 to 30 RPM of each other and return the selector switch to the phase position.

Keep the function switch in manual position except when desiring automatic control. The engine synchrophaser will bring into phase, engines with an RPM difference of over 30 RPM. However, the closer the RPM is set manually the sooner automatic phasing will be established.

Note the lack of an audio beat when the propellers are in phase; this should be checked in flight. When an audible beat is heard with the system operating, it is undoubtedly not holding the slave engine in phase with the master engine. Return the selector switch to its manual position for 45 seconds and readjust engine RPM manually to operating RPM. Set selector switch to phase position for automatic operation. If the phasing is not established after the above procedure, it is possible that some unit of the system is not operating properly, and further ground checks should be made.

14-119. OPERATIONAL CHECKS. (PA-23-250 (six place), Serial Nos. 27-3944 thru 27-7854067 only.)

The following checks may be made to evaluate system operating condition. A test unit should be fabricated to perform the required checks. Refer to Figure 14-46 for parts and wiring schematic to fabricate the test unit.

a. Connect an ammeter with a two ampere scale to the meter jack on the front panel of computer amplifier. (Refer to Figure 14-46.) Use a suitable cable and 1/4 inch phone plug to connect to the computer.

NOTE

When fabricating this test box, it is advisable to make the connecting cable long enough to extend from the computer into the cockpit.

b. Connect a zero center reading 15 volt voltmeter to test wires A and B in the six pin plug which connects to the computer. When the tests are completed the wires can be taped and tied back. (Refer to Figure 14-46.)

c. With meters connected as shown in Figure 14-46, proceed with the ground checks to determine if various units are working properly.

d. Connect the phone plug from the test box to the computer and observe the ammeter, it should show a reading with the master switch ON. This will confirm that there is voltage to the computer.

NOTE

The following steps should be performed from within the cockpit with the use of the aircraft starter switches.

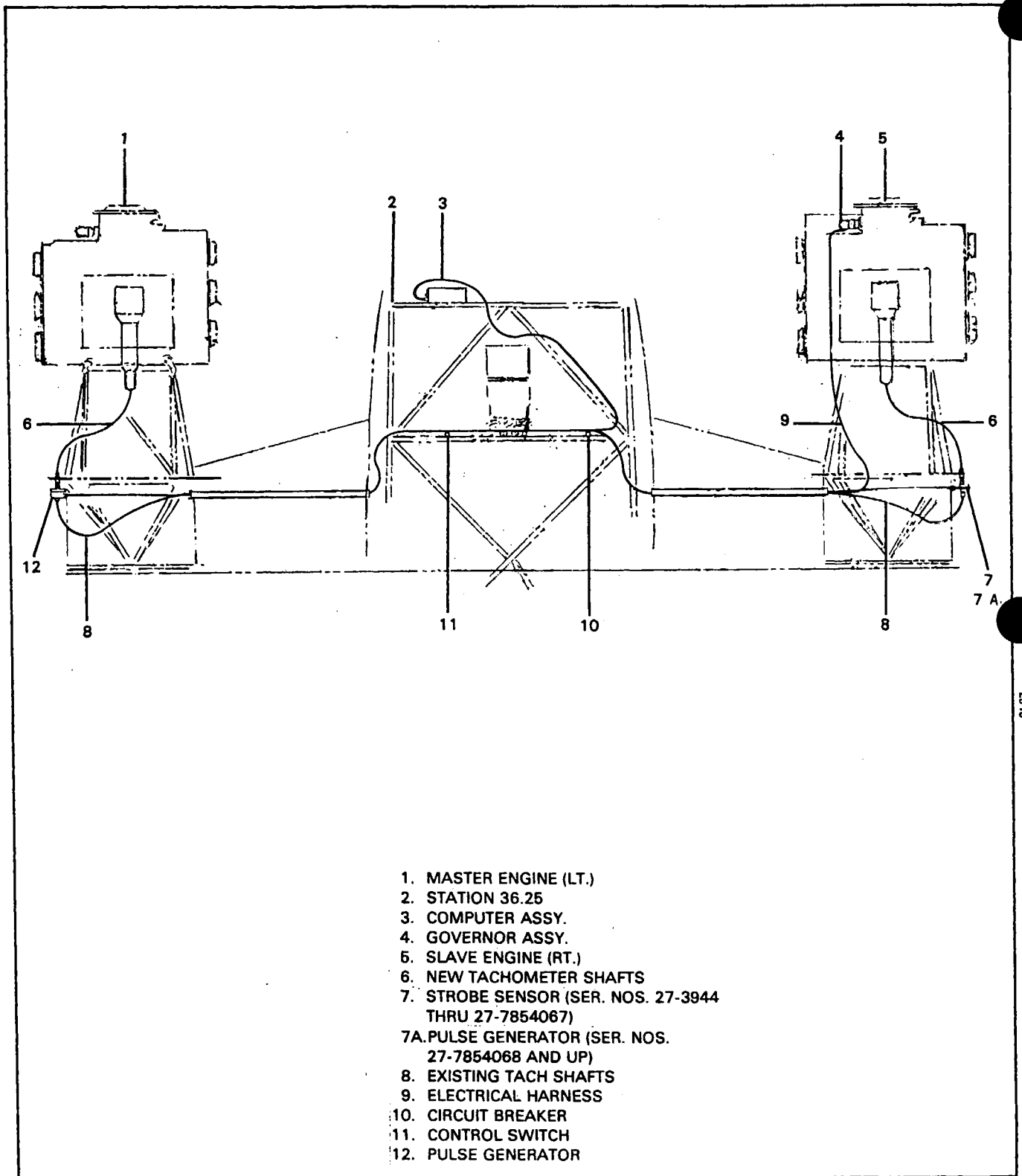

- 1. MASTER ENGINE (LT.)
- 2. STATION 36.25
- 3. COMPUTER ASSY.
- 4. GOVERNOR ASSY.
- 5. SLAVE ENGINE (RT.)
- 6. NEW TACHOMETER SHAFTS
- 7. STROBE SENSOR (SER. NOS. 27-3944 THRU 27-7854067)
- 7A. PULSE GENERATOR (SER. NOS. 27-7854068 AND UP)
- 8. EXISTING TACH SHAFTS
- 9. ELECTRICAL HARNESS
- 10. CIRCUIT BREAKER
- 11. CONTROL SWITCH
- 12. PULSE GENERATOR

Figure 14-42. Synchrophaser Installation

PIPER AZTEC SERVICE MANUAL

e. Ascertain that the magneto switches are OFF. Turn the master switch ON, and set the synchrophaser switch on MANUAL. Read the solenoid current on the ammeter. A stabilized reading should be 1 ampere \pm .2 ampere.

NOTE

When first selecting the manual operation, the meter current maybe near zero or near maximum of meter scale. The solenoid current is slowly corrected and takes five to thirty-five seconds to stabilize.

NOTE

The above step must always proceed phase operation when flying or making ground checks. Always use manual selection for stand-by service.

f. Start and adjust the master LEFT engine at near cruise RPM (2200 RPM or above). Set the selector switch to propeller sync. Rotate the slave RIGHT engine with the use of the starter (right Magneto switch OFF) until the zero center reading voltmeter deflects to the right or left of center. A full deflection to the right indicates a photo conductor is supplying a signal to the computer amplifier and must cause the ammeter to increase slowly to a maximum of approximately 1.75 amperes.

g. When the above condition is met, rotate the slave RIGHT engine with the use of the starter to a position that will cause the zero center reading voltmeter to deflect to left of center. A full deflection to left must cause a slow amperage decrease to 0 amps. This indicates that the other conductor is supplying a signal to the computer amplifier.

NOTE

A decrease in solenoid current indicates the slave engine is increasing RPM. An increase in solenoid current indicates the slave engine is decreasing RPM.

When conditions of step h and i are met, it will confirm that all components are operating.

h. Return the selector switch to manual and start the slave RIGHT engine. Operate the master LEFT engine at near cruise RPM. Set the selector switch to propeller sync position and advance the slave engine speed slightly over that of the master engine noting the deflection of the voltmeter. If it remains to the right decidedly longer than it remains on left, it confirms that the signals from the photo conductors are correct.

i. While still operating the master engine at near cruise RPM, retard revolutions of the slave engine to less than that of master engine. Note the deflection of the voltmeter. If it remains to the left decidedly longer than it remains on the right, it confirms that the signals from the photo conductors are correct.

NOTE

The voltmeter readings will change from side to side with RPM and phase changes, but will show a definite tendency to stay to right or left of zero when engine RPM's are not in phase.

14-120. TROUBLESHOOTING. The following checks should be made when a malfunction of the system is suspected. The checks are divided into two parts, Mechanical and Electrical, and should be performed in that order. A troubleshooting chart is also supplied at the end of these instructions.

CAUTION

Before proceeding any further be certain that the magneto switches are OFF.

- a. **MECHANICAL CHECKS (PA-23-250 (six place), Serial Nos. 27-3944 and up):** Inspect the short tach cables used to drive the pulse generator, strobe sensor (or other pulse generator in later models) and related components for the following conditions:
1. Insufficient lubrication. Lubricate with a suitable High Temperature Grease.
 2. The retainer clip on the drive end of the tach cable is not chafing against the bell housing. No signs of chafing should be evident.
 3. The square ends of the tach cable is fraying. If so, dip the end in silver solder or braze it. Then file the end square to fit mating unit core.
 4. Be certain the core of the pulse generator and strobe sensor (or other pulse generator in later models) rotate when the associated propeller is turned.
 5. Check the bulkhead tach drive units for possible broken parts.
 6. Check the engine drive pad for possible damage.
- b. **ELECTRICAL CHECKS (PA-23-250 (six place), Serial Nos. 27-3944 thru 27-7854067 only):** Perform the following checks to isolate any trouble in the electrical components of the system.

NOTE

To perform some of the following checks will require a standard multimeter with a 50 volt AC scale and/or other test equipment which can be fabricated from easily obtainable components. It is advisable to make the connecting cables long enough to extend into the cockpit.

1. Pulse generator, glow lamps and wire harness checks:
 - (a) Ascertain that all tach shafts are in position and rotate the pulse generator and strobe sensor with rotation of the respective engines.
 - (b) Start and run master engine at near cruise RPM. Set selector switch at Prop Sync.
 - (c) Disconnect plug PL3 at the strobe sensor and measure AC voltage at pins D to ground coming from the computer.
 - (d) Measure AC voltage at pin E to ground coming from the computer.
 - (e) These open circuit readings should be from 30 to 40 volts AC.

NOTE

The pulse generator may be removed and checked with the use of an electric drill or air motor regulated to limit the RPM to 1750. Drive the generator from the tang end of the core. A patch cable junction box may be fabricated to simplify the following checks. (Refer to Figure 14-50.)

- (f) Install the fabricated patch cable and check the volt ohmmeter readings at the patch cable junction box with the pulse generator running or the simulator installed.
 - (g) If this test is positive, a bad aircraft harness lead may be present. Check the harness with a megger ohmmeter.
 - (h) Check the resistance and continuity through the pulse generator harness. Pins D and E of the small plug attached to the computer should be approximately 200 ohms.
 - (i) Check the direction of the pulse generator by operating it from both ends and observe if lights in the strobe sensor illuminate. (Use the volt ohmmeter to check light illumination. A decrease in resistance should be read when the lights glow. Connect meter at pins A to C or B to C of the large plug). (The strobe sensor can also be disassembled for a direct visual check).
 - (j) To ascertain that the pulse generator is supplying timing information to strobe sensor, disconnect plug PL2 from the computer chassis and measure the AC voltage across contacts E and D while operating the master engine at near cruise RPM. A reading of .2 volts AC \pm .1 volts is considered normal. If no voltage is supplied, replace the pulse generator.
2. Computer amplifier:
 - (a) If the system operates in the manual mode but not in the phase mode, listen to the computer for an audible relay click when the system is switched from the manual mode to phase mode. The relay is on the bottom deck of the computer assembly. The use of a 2 amp meter and test plug will simplify this check. (Refer to Figure 14-46.)
 - (b) If no AC voltage is supplied to the strobe sensor as outlined in step 1d, it is suspected that the lamp amplifier in the computer chassis is defective and the computer should be replaced. (Refer to paragraphs 14-123 and 14-124.)

PIPER AZTEC SERVICE MANUAL

- (c) Inspect the inside of the computer to ascertain that the circuit boards are secure and that the tang plugs are free of corrosion. Also check for any loose wires.
- 3. Strobe sensor.
 - (a) Connect the fabricated strobe sensor tester (refer to Figure 14-48) to the strobe sensor plug in the right nacelle.
 - (b) Slowly rotate the strobe sensor core (if the tach shaft is disconnected) or propeller and watch for a drop in the photo conductor resistance. Check both A and B lights. The resistance should be 200,000 ohms with the lights covered and 180 ohms with the lights uncovered.
 - (c) If the latter test (Step b) proves negative the sensor unit must be disassembled for a visual check of lamp illumination. If the lamps do work the trouble is in the photo conductors. To be sure, aim the photo conductor cells at a source of light and move a finger or some object back and forth in front of the conductors. If the tester does not indicate a drop in resistance when the conductor cells are exposed to the light, they are inoperative and must be replaced.
 - (d) Connect the strobe sensor simulator. (Refer to Figure 14-49.) Move the potentiometer and listen to the computer. The motor should run at approximately 7 volts.
 - (e) Adjust the potentiometer just short of motor operation. Move the pressure-drain switch from ON - Pressure to OFF and then ON again; the current on the governor coil should be .05 amps.
 - (f) Move the switch from ON - drain to OFF and then ON again, the current on the governor coil should be .05 amps.

CAUTION

The pressure or drain should not be adjusted unless it is absolutely necessary and the system still does not synchronize.

c. **WIRING HARNESS CHECK (PA-23-250 (six place), Serial Nos. 27-7854068 and up):** This check utilizes a Hartzell Test Box B-4467 to provide assurance that the synchrophaser is properly connected. It also checks the functioning of the governor solenoid coil and the pulse generators.

NOTE

These tests are to be made with all parts installed and connected to the wiring harness except for the computer. Do not plug the computer in until all tests have been satisfactorily completed.

PIPER AZTEC SERVICE MANUAL

1. Connect the Hartzell Test Box B-4467 to the wiring harness in place of the computer.
2. Turn the master switch ON. The Power light and Coil light should come on. Other lights may also be on but they may be disregarded at this time with the exception of the Coil Short light. If it is on turn the master switch OFF and refer to the following NOTE.

NOTE

If any of the lights on the test box fail to operate correctly, check the wiring harness against the wiring diagram. Check for shorts, open circuit breaker, broken wires and wires connected to the wrong pins.

3. Rotate the right engine by hand and watch the Right Engine light. If the light is off rotate the engine until it comes on or vice versa. The engine may need to be rotated two revolutions to obtain a change. Repeat the procedure for the left engine observing the Left Engine light.
4. Place the phase-manual switch in the MANUAL position. The Manual light should come on and the Phase light should go out. When the switch is placed in the PHASE position the opposite should occur.
5. If the wiring harness checks good but the Right or Left Engine light or the Coil light does not function properly replace the respective pulse generator or the governor.

14-121. REMOVAL OF STROBE SENSOR. (PA-23-250 (six place), Serial Nos. 27-3944 thru 27-7854067 only.) This unit is located in the right engine nacelle aft of the firewall in the upper right hand corner. (Refer to Figure 14-42.)

- a. Remove the access panel on top of the nacelle.
- b. Loosen the knurled nut on the rear of the strobe sensor and remove the tachometer cable.
- c. Disconnect the electrical connector.
- d. Loosen the 1 inch hex nut, at the front of the strobe sensor, that connects it to the firewall adapter and remove the sensor.

14-122. INSTALLATION AND ADJUSTMENT OF STROBE SENSOR. (Refer to Figure 14-43.)

- a. Attach strobe sensor to firewall adapter by securing loosely with hex nut.

NOTE

The front of the strobe sensor can be defined by the square hole in the center of the unit to accept the square end of a tach shaft.

NOTE

Before proceeding any further be certain the magneto switches are OFF.

PIPER AZTEC SERVICE MANUAL

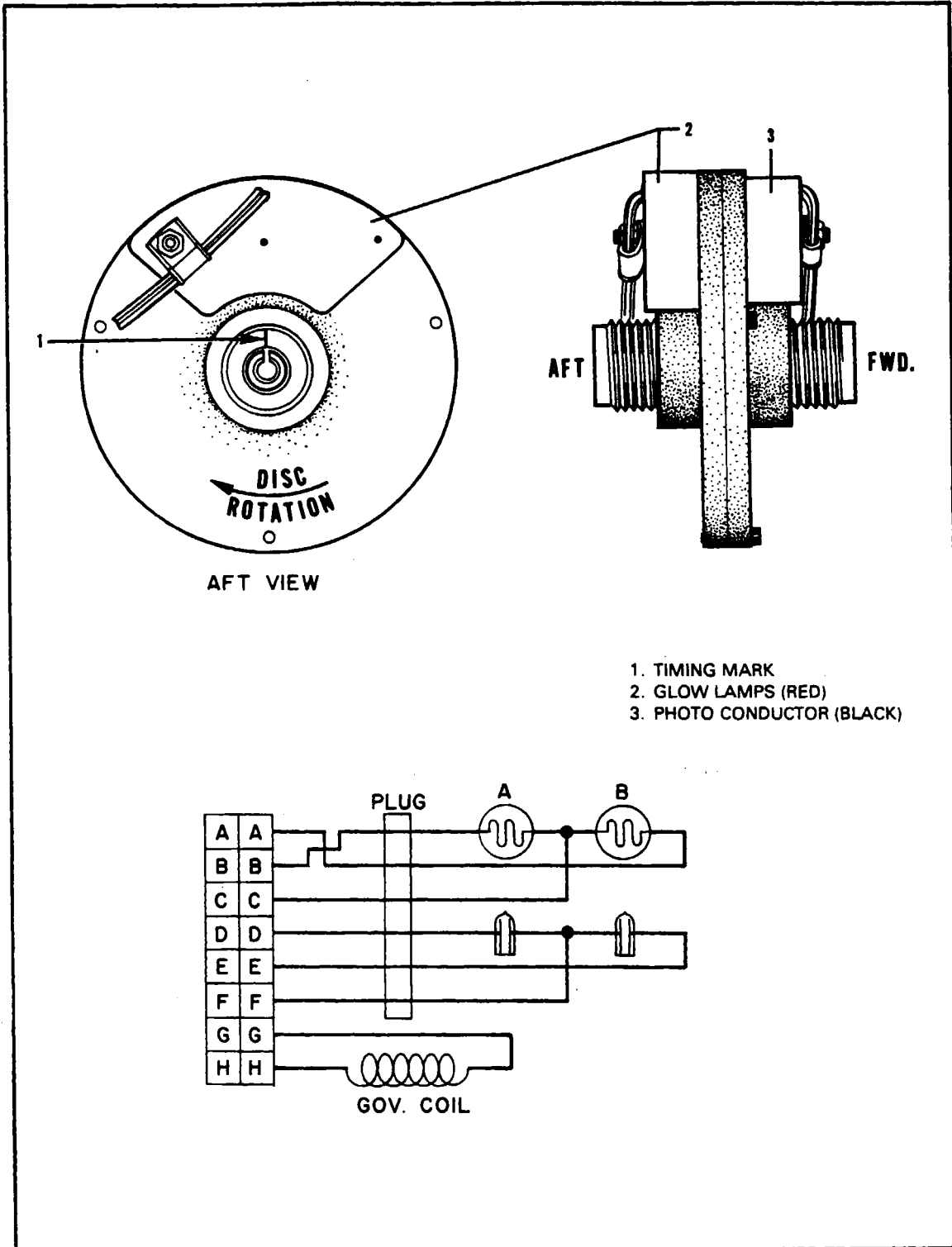

Figure 14-43. Strobe Sensor

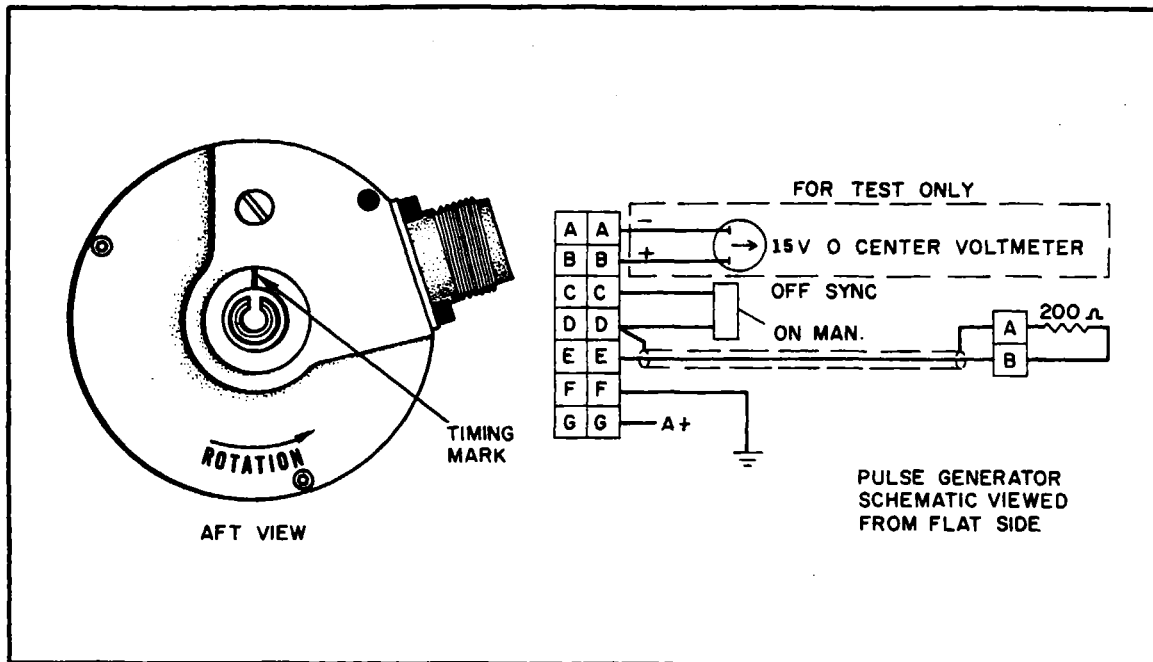

Figure 14-44. Pulse Generator

b. Turn the engine in the direction of rotation to locate No. 2 piston at T.D.C. on the ignition stroke. Use the engine timing mark. Move the propeller blade an additional 30 degrees. This is the timing position.

NOTE

If this point is missed, do not turn the engine backward, start over.

c. Turn the strobe sensor case counterclockwise (viewed from the rear) to align the timing mark with the center of the keyway. This is the phase position. The use of an inspection mirror will be required to view the end of the unit.

d. Tighten the 1 inch hex nut.

e. Pull the prop through (in the direction of rotation) two complete revolutions and stop at the phase position. Check timing mark alignment. Reset if necessary.

f. Connect tachometer shaft to the rear of the strobe sensor and secure with knurled nut.

g. Connect electrical plug connector to the strobe sensor and install the access panel on top of the nacelle.

14-123. REMOVAL OF PULSE GENERATOR. (See following NOTE.) This unit is located in the left engine nacelle aft of the firewall in the upper left hand corner. (Refer to Figure 14-42.)

a. Remove the access panel on top of the nacelle.

PIPER AZTEC SERVICE MANUAL

- b. Loosen the knurled nut on the rear of the pulse generator and remove the tachometer cable.
- c. Disconnect the electrical connector.
- d. Loosen the 1 inch hex nut, at the front of the pulse generator, that connects it to the firewall adapter and remove the generator.

NOTE

On Serial Nos. 27-7854068 and up, a second pulse generator is used in lieu of a strobe sensor in the right engine nacelle and it is removed as is described for the strobe sensor in Paragraph 14-121.

14-124. INSTALLATION AND ADJUSTMENT OF PULSE GENERATOR. (Refer to Figure 14-44.)

- a. Attach the pulse generator to the bulkhead drive unit by securing loosely with hex nut.

NOTE

The front of the pulse generator can be defined by the square hole in the center of the unit to accept the square end of a tach shaft.

CAUTION

Before proceeding further, be certain the magneto switches are OFF.

- b. Turn the engine in the direction of rotation to locate No. 1 piston at T.D.C. on the ignition stroke. Use the engine timing mark.

NOTE

If this point is missed, do not turn the engine backward, start over.

- c. Turn the pulse generator case counterclockwise (viewed from the rear) to align the timing mark with the center of the keyway. This is the phase position. The use of an inspection mirror will be required to view the end of the unit.
- d. Tighten the 1 inch hex nut.
- e. Pull the prop through (in the direction of rotation) two complete revolutions and stop at the phase position. Check timing mark alignment. Reset if necessary.

NOTE

The pulse generator timing mark is always set up when the master engine is at T.D.C. of No. 1 cylinder on the ignition stroke. The slave engine is then set at the desired propeller position, cylinder number and ignition stroke. This is predetermined at the factory and is different for each model aircraft.

- f. Connect tachometer shaft to rear of pulse generator and secure with knurled nut.
- g. Connect the electrical plug connector to the pulse generator and install the access panel on top of the nacelle.

14-125. REMOVAL OF COMPUTER ASSEMBLY. This unit is located in the nose section on the front of bulkhead station 36.25 in the upper center portion. (Refer to Figure 14-42.)

- a. The computer unit is accessible through the top rear opening of the nose baggage compartment.
- b. Disconnect the two electrical plugs connected to the computer unit.
- c. Remove the three machine screws on the top mounting flange and lift the computer unit up and out of the aircraft.

14-126. INSTALLATION OF COMPUTER ASSEMBLY. (Refer to Figure 14-42.)

- a. Position the bottom mounting flange of the computer unit into the slot along the bottom of the mounting plate.
- b. Secure the unit in place with the three machine screws in the top mounting flange.
- c. Connect the two electrical plugs to the computer unit.
- d. Check the fuse to ascertain that it is in good condition and of the proper size (3 amp - 250 volts).

14-127. REMOVAL AND INSTALLATION OF GLOW LAMP AND PHOTO CONDUCTOR ASSEMBLIES.

- a. Remove the strobe sensor in accordance with paragraph 14-120.

NOTE

A reference mark should be placed along the edge of the sensor unit to facilitate getting the proper alignment of part upon reassembly.

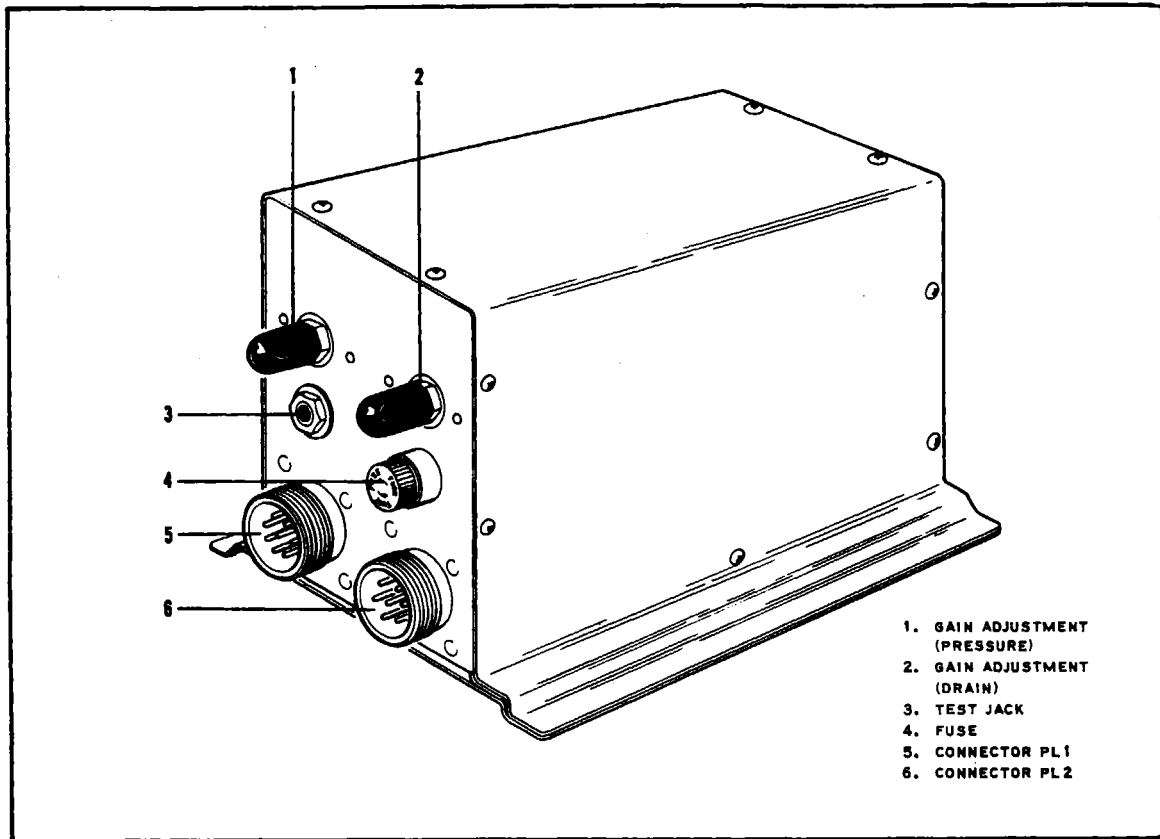

Figure 14-45. Computer Assembly

- b. Remove the three allen cap screws holding the two halves of the strobe sensor together. It may be necessary to tap the center shaft to separate the halves.
- c. Reconnect plug PL3 and visually observe if both glow lamps light with the master engine turning at near cruising RPM. A pulse generator simulator may be used according to paragraph 14-120 and Figure 14-51.
- d. If either of the glow lamps is inoperative, the red colored block that holds the lamps must be replaced. This is done by removing the three countersunk screws, one with an external nut, from inside the strobe sensor case and removing the block assembly. Install the new one by using the removal method in reverse.
- e. If the photo conductors are inoperative, the black colored block assembly may be replaced in the same method as the glow lamps, step d, above.
- f. Place the two halves of the strobe sensor together and align the previously made reference marks.
- g. Secure the two halves of the unit together with the three allen cap screws.
- h. Install the strobe sensor in the airplane and adjust it in accordance with paragraph 14-122.

PIPER AZTEC SERVICE MANUAL

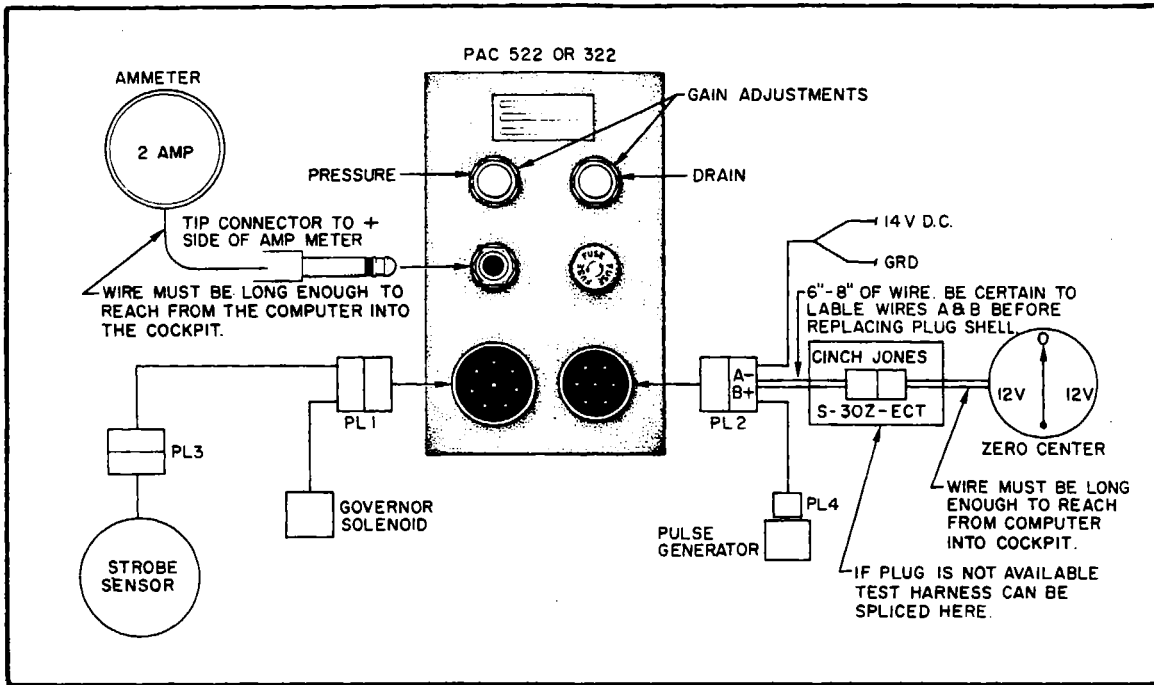

Figure 14-46. Fabricated Test Box

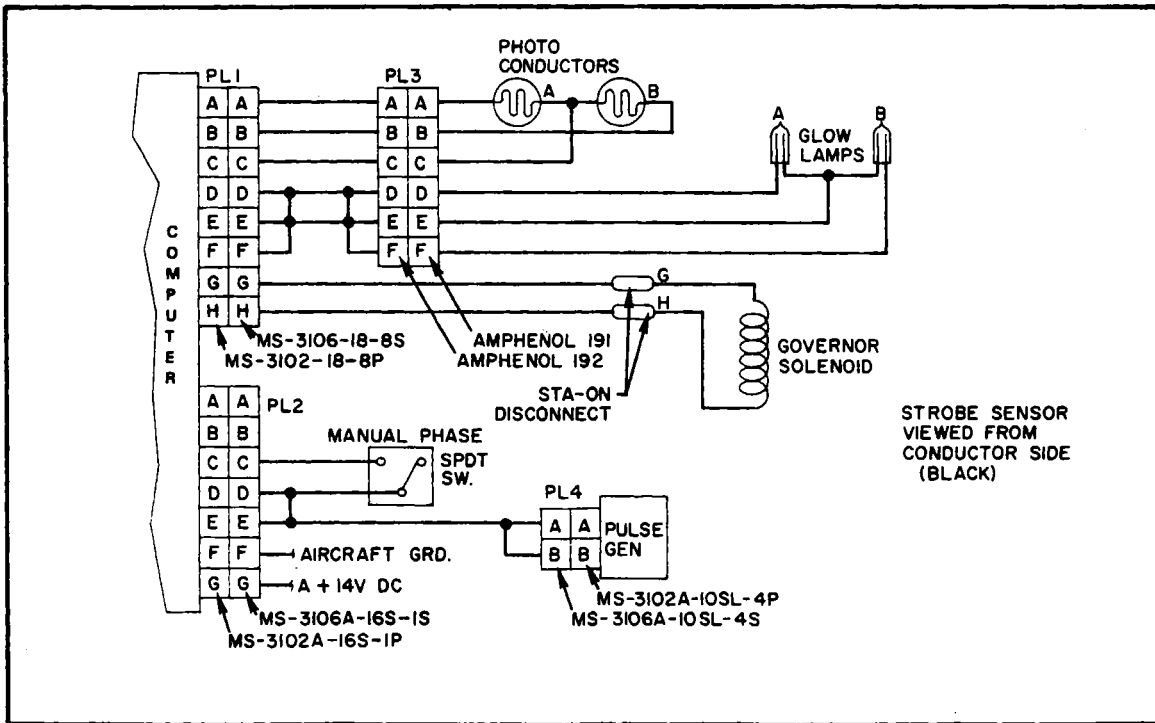

Figure 14-47. Electrical Schematic

PIPER AZTEC SERVICE MANUAL

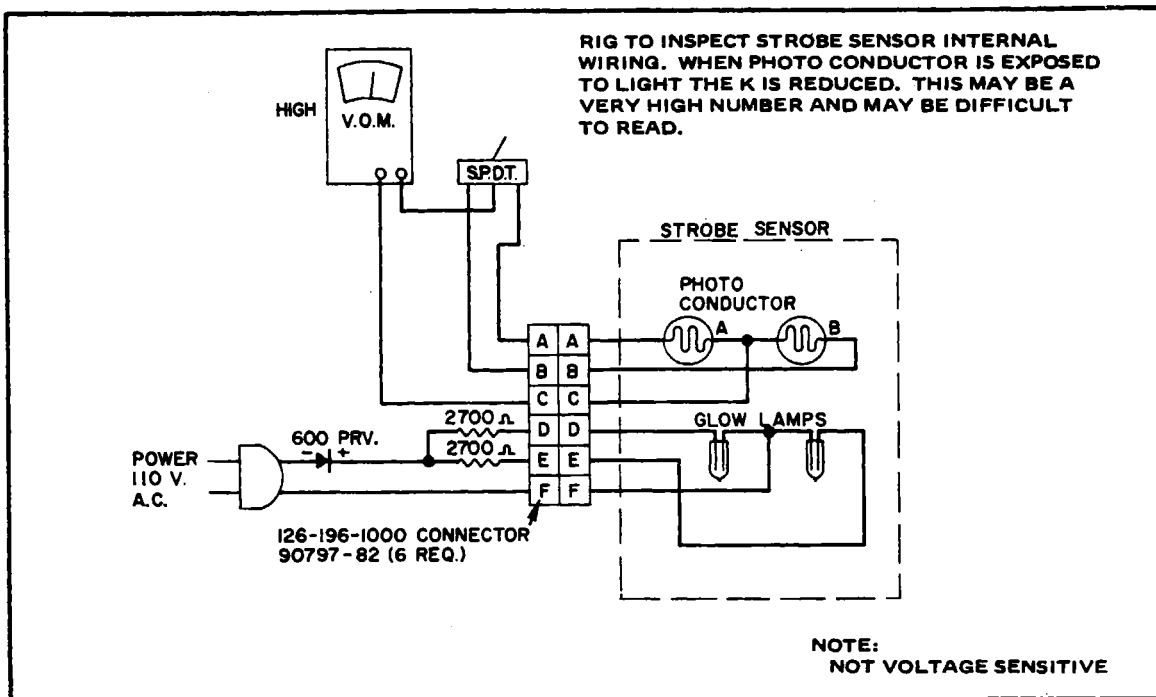

Figure 14-48. Strobe Sensor Internal Wiring Test Unit

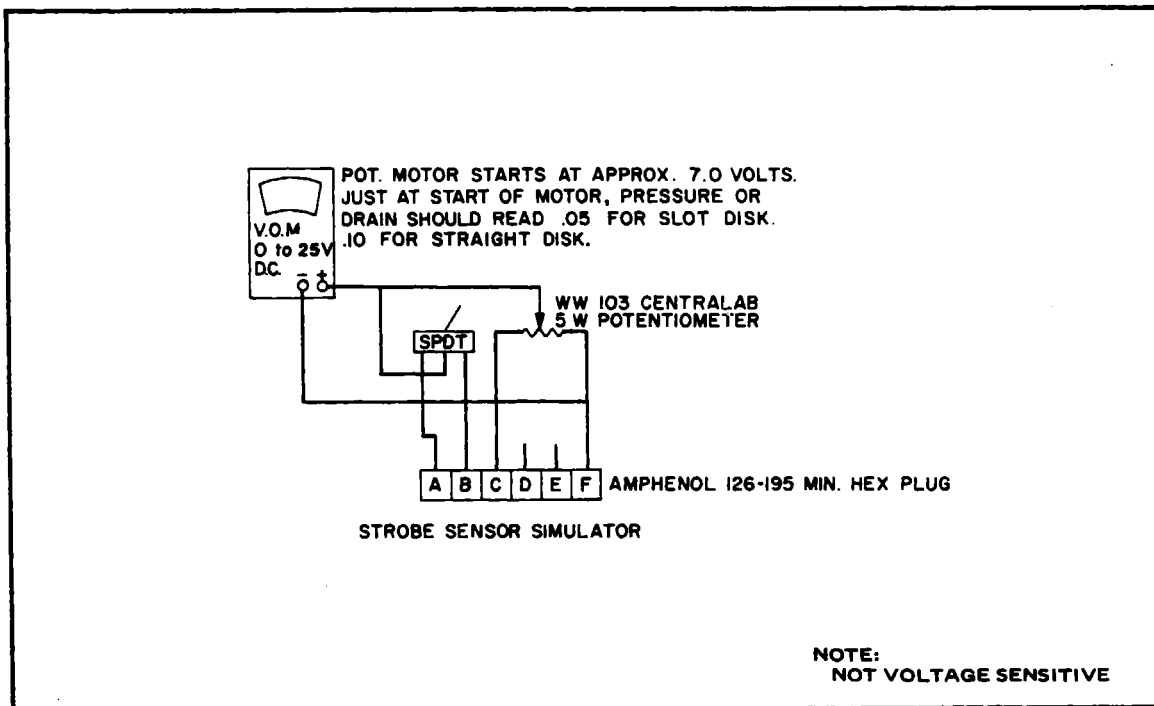

Figure 14-49. Strobe Sensor Simulator

PIPER AZTEC SERVICE MANUAL

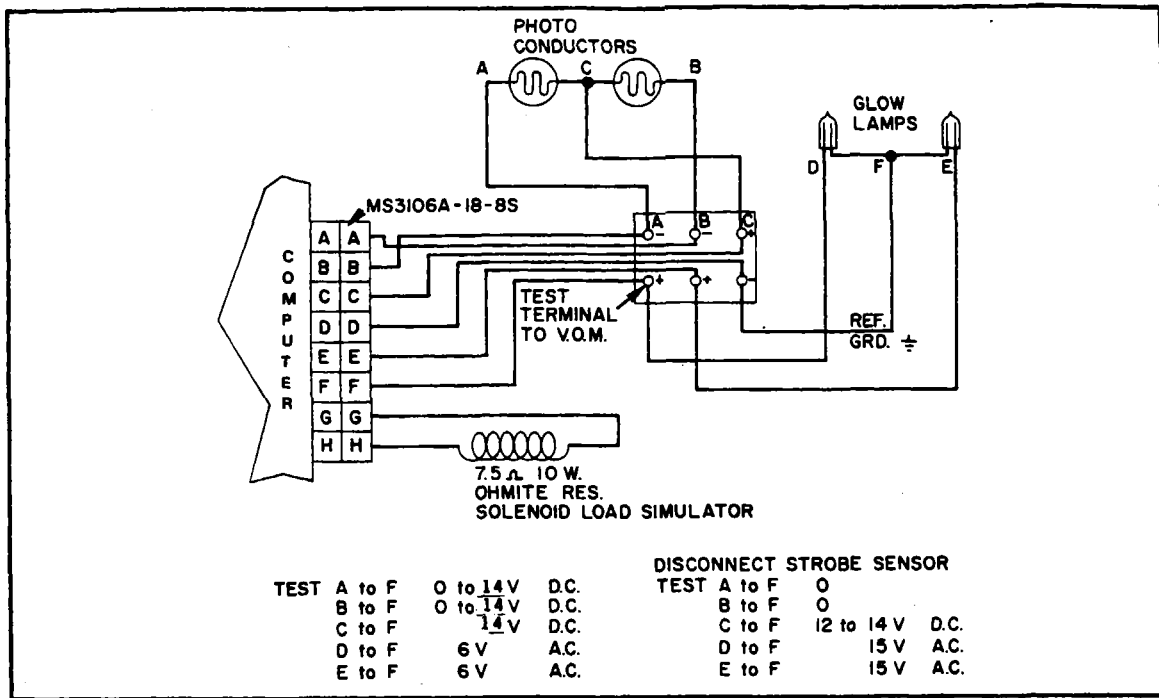

Figure 14-50. Patch Cable and Test Terminal

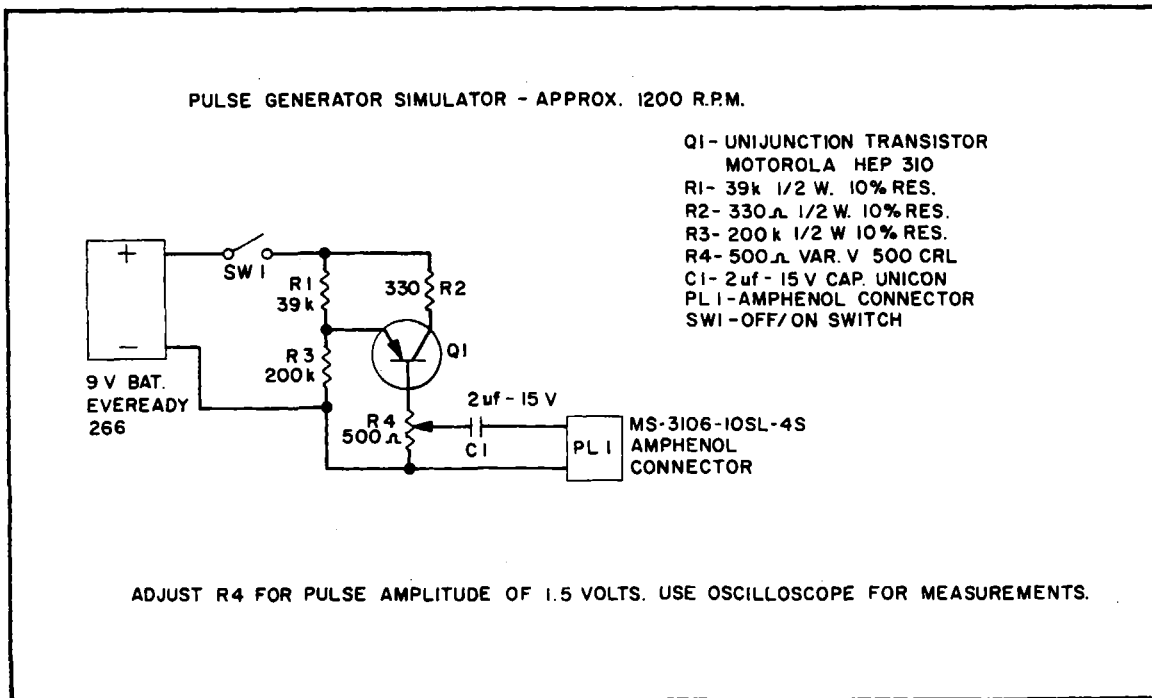

Figure 14-51. Pulse Generator Simulator

PIPER AZTEC SERVICE MANUAL

TABLE XIV-V. TROUBLESHOOTING CHART (ENGINE SYNCHROPHASER)

Trouble	Cause	Remedy
<p>No indication solenoid current.</p>	<p>Master switch OFF.</p> <p>Bad fuse in computer.</p> <p>Faulty wiring.</p> <p>Faulty computer.</p>	<p>Turn switch ON.</p> <p>Replace fuse.</p> <p>Check wiring and connections.</p> <p>Replace computer.</p>
<p>System not operating properly.</p>	<p>Pulse generator and lamp amplifier suspected of faulty operation.</p> <p>Tach shafts faulty.</p> <p>Pulse generator and glow lamp amplifier in computer not operating.</p> <p>Glow lamp or lamps and/or photo conductor or conductors defective.</p> <p>Faulty computer.</p>	<p>Perform operational check in accordance with paragraph 14-119.</p> <p>Visually check tach shafts.</p> <p>Perform electrical test in accordance with paragraph 14-120.</p> <p>Replace glow lamp or photo conductor assemblies. Refer to paragraph 14-127.</p> <p>Perform electrical test in accordance with paragraph 14-120.</p>
<p>System will not sync. (Note) Unit will not sync. on the ground.</p>	<p><u>Electrical.</u></p> <p><u>Mechanical.</u></p> <p><u>Pilot.</u> Engines not set within range of system.</p>	<p>Perform electrical test in accordance with paragraph 14-120.</p> <p>Check tach shafts per paragraph 14-120.</p> <p>Refer to paragraph 14-118 for operating procedures.</p>

PIPER AZTEC SERVICE MANUAL

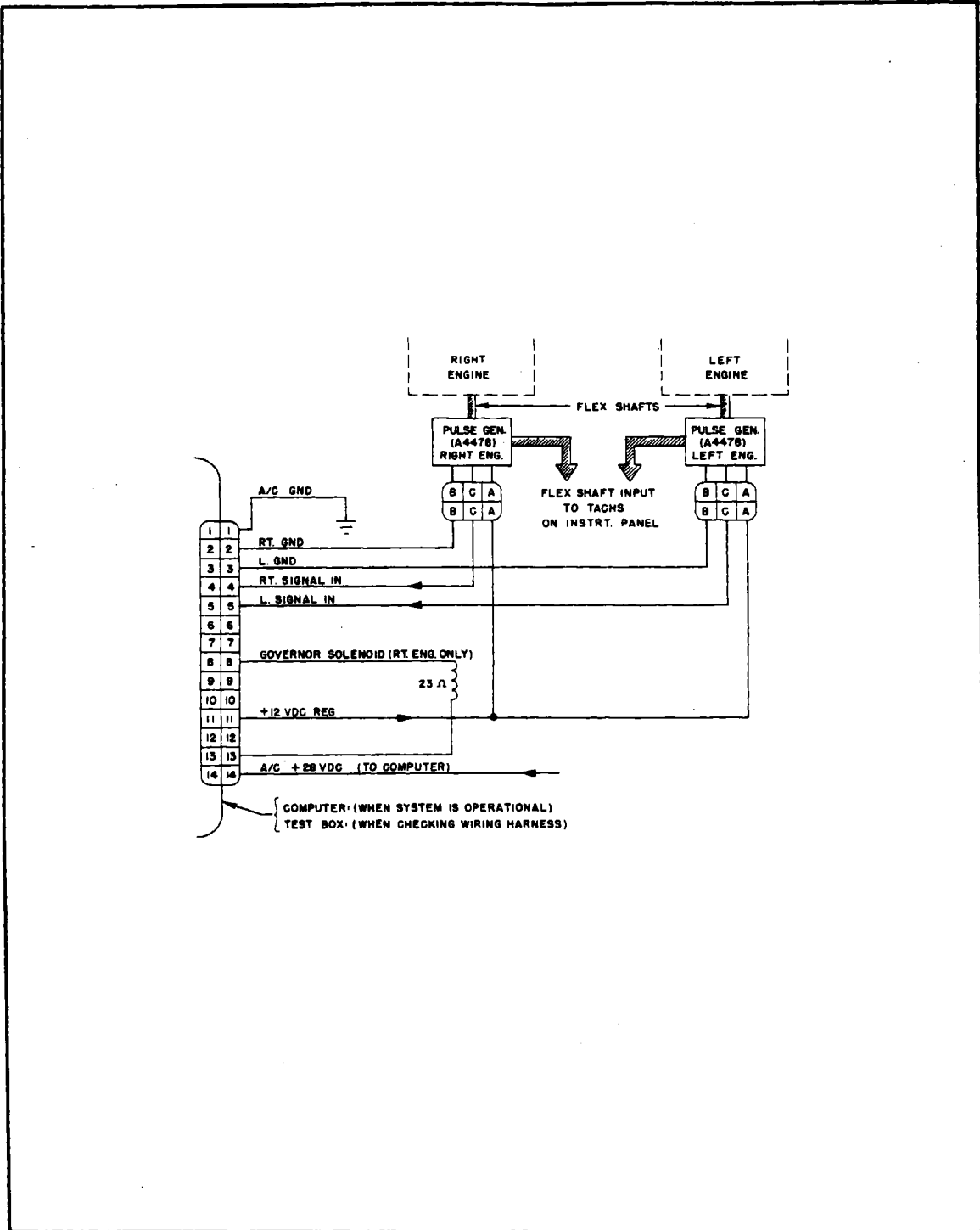

Figure 14-52. Synchrophaser Schematic,
PA-23-250 (six place), Serial Nos. 27-7854068 and up