



# GTR 225/GNC 255 TSO Installation Manual



© 2012-2015

Garmin International, Inc., or its subsidiaries  
All Rights Reserved

Except as expressly provided herein, no part of this manual may be reproduced, copied, transmitted, disseminated, downloaded or stored in any storage medium, for any purpose without the express prior written consent of Garmin. Garmin hereby grants permission to download a single copy of this manual and of any revision to this manual onto a hard drive or other electronic storage medium to be viewed and to print one copy of this manual or of any revision hereto, provided that such electronic or printed copy of this manual or revision must contain the complete text of this copyright notice and provided further that any unauthorized commercial distribution of this manual or any revision hereto is strictly prohibited.

At Garmin, we value your opinion. For comments about this guide, please e-mail:

[Techpubs.Salem@garmin.com](mailto:Techpubs.Salem@garmin.com).

Garmin International, Inc.  
1200 E. 151st Street  
Olathe, KS 66062 USA  
Telephone: (913) 397-8200  
Aviation Dealer Technical Support Line (Toll Free): (888) 606-5482  
Website address: [www.garmin.com](http://www.garmin.com)

Garmin (Europe) Ltd.  
Liberty House  
Bulls Copse Road  
Hounslow Business Park  
Southampton, SO40 9LR, UK  
Telephone: 44 (0) 23 8052 4000  
Fax: 44 (0) 23 8052 4004

Garmin AT, Inc.  
2345 Turner Rd. SE  
Salem, Oregon 97302  
Telephone: (503) 581-8101

## RECORD OF REVISIONS

Revision	Revision Date	Description
D	12/12/13	Updated serial port configuration and other minor edits. See Current Revision Description for details.
E	8/25/14	Add NV data and other minor edits. See Current Revision Description for details.
F	3/25/15	Added v2.10 functionality and other minor edits. See Current Revision Description for details.

## CURRENT REVISION DESCRIPTION

Section Number	Description of Change
Global	Updated screenshots where applicable.
	Rewrote many sections for clarity.
1.3	Renamed section to, "General Specifications." Merged general specifications to table 1-2.
1.5	Added speaker audio output and maximum audio output reduction to table 1-5.
1.10	Renamed section to, "Certification."
4.5	Added table 4-6, "Socket Contact P/Ns."
5.2.4.2.2	Added an NMEA standard GPS messages to section.
5.2.4.2.3	Added COM and NAV keypad command messages to section.
6.4.2.2	Added new section, "Calibrate OBS Resolver Page (GNC Only).
6.4.3.2	Added information and tables about COM RX squelch settings.
6.4.4.1	Added table 6-13, "COM Sidetone Mode Selections" and table 6-14, "COM Sidetone Pilot Control."
6.8.2	Added table 6-16, "Software Compatibility."
B.2.4.1.7	Added new section, "COM Keypad Input (Display Software Version 2.10 or later).
B.2.4.1.13	Added new section, "NAV Keypad Input (Display Software Version 2.10 or later).
Appendix D	Added GNS 480 to figure D-15.
	Added figure D-16, "GTR/GNC-GMX 200 Interconnect."

## INFORMATION SUBJECT TO EXPORT CONTROL LAWS

This document may contain information which is subject to the Export Administration Regulations (EAR) issued by the United States Department of Commerce (15 CFR, chapter VII, subchapter C) and which may not be exported, released, or disclosed to foreign nationals inside or outside of the United States without first obtaining an export license. A violation of the EAR may be subject to a penalty of up to 10 years imprisonment and a fine of up to \$1,000,000 under Section 2410 of the Export Administration Act of 1979. Include this notice with any reproduced portion of this document.

This information in this document is subject to change without notice. Visit Garmin's website ([www.garmin.com](http://www.garmin.com)) for updates and supplemental information concerning the operation of Garmin products.

## DEFINITIONS OF WARNINGS, CAUTIONS, AND NOTES



### **WARNING**

*Warnings indicate immediate attention must be given to avoid potential personal injury or equipment damage should the instructions be disregarded.*



### **CAUTION**

*Cautions indicate an alert to potential damage to the equipment if the procedural step is not directly followed.*



### **NOTE**

*Notes indicate additional information is needed.*

**WARNING**

*This product, its packaging, and its components contain chemicals known to the State of California to cause cancer, birth defects, or reproductive harm. This notice is being provided in accordance with California's Proposition 65. If you have any questions or would like additional information, please refer to our website at [www.garmin.com/prop65](http://www.garmin.com/prop65).*

**WARNING**

*Perchlorate Material – special handling may apply.  
Refer to [www.dtsc.ca.gov/hazardouswaste/perchlorate](http://www.dtsc.ca.gov/hazardouswaste/perchlorate).*

**WARNING**

*This product contains a lithium battery that must be recycled or disposed of properly.  
Battery replacement and removal must be performed by professional services.*

**CAUTION**

*To avoid damage to the GTR 225 or GNC 255, take precautions to prevent Electrostatic Discharge (ESD) when handling the GTR, connectors, fan, and associated wiring. ESD damage can be prevented by touching an object of the same electrical potential as the unit before handling the unit itself.*

**NOTE**

*Garmin recommends installation of the GTR 225/GNC 255 by a Garmin authorized installer. To the extent allowable by law, Garmin will not be liable for damages resulting from improper or negligent installation of the GTR 225/GNC 255. For questions, please contact Garmin Aviation Product Support at (888) 606-5482.*

## TABLE OF CONTENTS

<b>1</b>	<b>GENERAL DESCRIPTION .....</b>	<b>1-1</b>
1.1	Introduction .....	1-1
1.2	Equipment Description .....	1-1
1.3	General Specifications .....	1-3
1.4	COM Specifications .....	1-4
1.5	VOR Specifications .....	1-6
1.6	LOC Specifications .....	1-7
1.7	Glideslope Specifications .....	1-8
1.8	Current Draw Specifications .....	1-9
1.9	License Requirements .....	1-10
1.10	Certification .....	1-11
1.11	GTR/GNC Database .....	1-13
1.12	Aviation Limited Warranty .....	1-14
<b>2</b>	<b>LIMITATIONS .....</b>	<b>2-1</b>
2.1	Installation .....	2-1
2.2	Aircraft Radio .....	2-1
<b>3</b>	<b>INSTALLATION OVERVIEW .....</b>	<b>3-1</b>
3.1	Introduction .....	3-1
3.2	Antenna Considerations .....	3-1
3.3	GTR/GNC Mounting Considerations .....	3-2
3.4	Cabling and Wiring Considerations .....	3-3
3.5	Air Circulation and Cooling .....	3-3
3.6	Compass Safe Distance .....	3-3
<b>4</b>	<b>INSTALLATION PROCEDURES .....</b>	<b>4-1</b>
4.1	Unit and Accessories .....	4-1
4.2	Miscellaneous Options .....	4-1
4.3	Optional Reference Material .....	4-2
4.4	Installation Materials Required but not Supplied .....	4-2
4.5	Special Tools Required .....	4-3
4.6	Coaxial Cable Installation .....	4-4
4.7	Equipment Mounting .....	4-4
4.8	COM Antenna Installation and Connections .....	4-5
<b>5</b>	<b>CONNECTOR PINOUT INFORMATION .....</b>	<b>5-1</b>
5.1	Pin Function List .....	5-1
5.2	Power, Lighting, And Antennas .....	5-5
<b>6</b>	<b>POST INSTALLATION CONFIGURATION AND CHECKOUT PROCEDURES .....</b>	<b>6-1</b>
6.1	System Configuration Overview .....	6-1
6.2	Mounting, Wiring, and Power Checks .....	6-1
6.3	Connector Engagement Check .....	6-2
6.4	Configuration Mode Operations .....	6-2
6.5	Ground Checks (Configuration Mode) .....	6-16
6.6	Ground Checks (Normal Mode) .....	6-19
6.7	Flight Checks .....	6-22
6.8	Software Loading .....	6-23
<b>7</b>	<b>CONTINUED AIRWORTHINESS .....</b>	<b>7-1</b>
	<b>APPENDIX A ENVIRONMENTAL QUALIFICATION FORM .....</b>	<b>A-1</b>

**TABLE OF CONTENTS CONTINUED**

**APPENDIX B GTR/GNC DATA FORMAT ..... B-1**

    B.1 RS-232 Aviation Format ..... B-1

    B.2 RS-232 NMEA Data Format ..... B-5

**APPENDIX C MECHANICAL DRAWINGS ..... C-1**

    C.1 Drawing List ..... C-1

**APPENDIX D INTERCONNECT DIAGRAMS ..... D-1**

    D.1 Drawing List ..... D-1

## LIST OF FIGURES

Figure 6-1	Configuration Mode Page .....	6-2
Figure 6-2	Serial Port Page .....	6-3
Figure 6-3	DST Priority Page .....	6-3
Figure 6-4	Intercom Enable Page .....	6-4
Figure 6-5	Backlight Page .....	6-4
Figure 6-6	Photocell Page .....	6-5
Figure 6-7	Lighting Bus Page .....	6-6
Figure 6-8	Display Information Pages .....	6-6
Figure 6-9	Software Update Page .....	6-7
Figure 6-10	CDI Indicator Page .....	6-7
Figure 6-11	Calibrate OBS Resolver Page .....	6-8
Figure 6-12	ARINC 429 Page .....	6-8
Figure 6-13	NAV Information Page .....	6-10
Figure 6-14	NAV Software Update Page .....	6-10
Figure 6-15	MIC Gain Page .....	6-11
Figure 6-16	COM RX Squelch Page .....	6-11
Figure 6-17	COM Information Page .....	6-12
Figure 6-18	COM Software Update Page .....	6-13
Figure 6-19	COM Sidetone Page .....	6-13
Figure 6-20	Mix NAV Audio Page .....	6-14
Figure 6-21	Hi-Fidelity Audio Page .....	6-14
Figure 6-22	Download Log Page .....	6-15
Figure 6-23	Clear Error Logs Page .....	6-15
Figure 6-24	Calibrate OBS Resolver Page .....	6-16
Figure 6-25	Test Analog Flags Page .....	6-17
Figure 6-26	Test CDI/VDI Page .....	6-18
Figure 6-27	USB Update Progress .....	6-24
Figure 6-28	Database Update Page .....	6-25
Figure 6-29	Database Info Page .....	6-25
Figure C-1	GTR/GNC Dimensions .....	C-2
Figure C-2	GTR/GNC Mounting Rack .....	C-3
Figure C-3	GNC Center of Gravity .....	C-4
Figure C-4	GTR Center of Gravity .....	C-5
Figure C-5	GTR/GNC Rear Connector Layout Detail .....	C-6
Figure C-6	Panel Cutout Detail .....	C-7
Figure C-7	GTR Mounting Rack .....	C-8
Figure D-1	GTR/GNC System Interface Diagram .....	D-2
Figure D-2	GTR/GNC Typical Installation .....	D-3
Figure D-3	GTR/GNC Power Lighting Configuration Interconnect .....	D-5
Figure D-4	GTR/GNC - Antennas Interconnect .....	D-6
Figure D-5	GTR/GNC - Audio Panel Interconnect .....	D-10
Figure D-6	GTR/GNC - MIC Interconnect .....	D-12
Figure D-7	GNC - VOR/ILS Interconnect .....	D-13
Figure D-8	GTR/GNC Switches Interconnect .....	D-15
Figure D-9	GNC - RMI OBI Interconnect .....	D-16
Figure D-10	GNC - King Serial DME - Remote Mount Interconnect .....	D-17
Figure D-11	GNC - Parallel 2 of 5 DME Tuning Interconnect .....	D-19
Figure D-12	GNC - Parallel Slip Code DME Tuning Interconnect .....	D-21



### LIST OF FIGURES CONTINUED

Figure D-13	GNC - King Serial DME - Panel Mount Interconnect .....	D-22
Figure D-14	GNC - GDU 620 Interconnect .....	D-24
Figure D-15	GTR/GNC - GTN 6XX/7XX, GNS 400W/500W, and GNS 480 Interconnect .....	D-25
Figure D-16	GTR/GNC - GMX 200 Interconnect .....	D-26

## LIST OF TABLES

Table 1-1	TSO-Certified Units .....	1-1
Table 1-2	Physical Specifications .....	1-3
Table 1-3	Display Specifications .....	1-3
Table 1-4	COM Transmitter Specifications .....	1-4
Table 1-5	COM Receiver Specifications .....	1-5
Table 1-6	VOR Specifications .....	1-6
Table 1-7	LOC Specifications .....	1-7
Table 1-8	Glideslope Specifications .....	1-8
Table 1-9	GTR/GNC Current Draw Specifications .....	1-9
Table 1-10	TSO Authorization and Advisory Circular References .....	1-11
Table 1-11	System Functions .....	1-11
Table 4-1	Catalog P/Ns .....	4-1
Table 4-2	Standard Kit Accessories .....	4-1
Table 4-3	Miscellaneous Options .....	4-1
Table 4-4	Optional Reference Material .....	4-2
Table 4-5	Recommended Crimp Tools (or Equivalent) .....	4-3
Table 4-6	Socket Contact P/Ns .....	4-3
Table 6-1	Serial Port Selections .....	6-3
Table 6-2	Intercom Enable Page Selections .....	6-4
Table 6-3	Backlight Selections .....	6-4
Table 6-4	Photocell Page Parameter Description .....	6-5
Table 6-5	Lighting Bus Parameter Description .....	6-6
Table 6-6	CDI Indicator Selections .....	6-7
Table 6-7	ARINC 429 Configuration Speed (TX) .....	6-8
Table 6-8	SDI Selections .....	6-8
Table 6-9	DME Settings .....	6-9
Table 6-10	A429 Settings.....	6-9
Table 6-11	COM RX Squelch Selections .....	6-12
Table 6-12	COM RX Squelch Settings .....	6-12
Table 6-13	COM Sidetone Mode Selections .....	6-13
Table 6-14	COM Sidetone Pilot Control .....	6-14
Table 6-15	Discrete Input Pins .....	6-19
Table 6-16	Software Compatibility .....	6-23
Table B-1	Aviation Output Sentence Format .....	B-2
Table B-2	Type 2 Aviation Output Sentence Format .....	B-4
Table B-3	Input Message Summary .....	B-21
Table B-4	Output Message Summary .....	B-21

### GTR 225/GNC 255 HARDWARE MOD LEVEL HISTORY

The following table identifies hardware modification (Mod) Levels for the GTR 225, GTR 225A, GTR 225B, GNC 255A, and GNC 255B. Mod Levels are listed with the associated service bulletin number, service bulletin date, and the purpose of the modification. The table is current at the time of publication of this manual and is subject to change without notice. Authorized Garmin sales and service centers are encouraged to access the most up-to-date bulletin and advisory information at Garmin's [Dealer Resource Center](#) using their Garmin-provided user name and password.

<b>Mod Level</b>	<b>Service Bulletin Number</b>	<b>Service Bulletin Date</b>	<b>Purpose Of Modification</b>
1	SB 1404	2/7/14	Some GNC 255 units may require upgrade to MOD 1 to prevent incorrect VOR or Localizer deviation indication in certain limited conditions.

# 1 GENERAL DESCRIPTION

## 1.1 Introduction

Information for the installation of a GTR 225, GTR 225A, GTR 225B, GNC 255A, or GNC 255B is provided in this manual. This manual is not a substitute for an approved airframe-specific maintenance manual, installation design drawing, or complete installation data package. Attempting to install equipment by reference to this manual alone and without first planning or designing an installation specific to your aircraft may compromise your safety and is not recommended. The content of this manual assumes use by competent and qualified avionics engineering personnel and/or avionics installation specialists using standard aviation maintenance practices in accordance with Title 14 of the Code of Federal Regulations and other relevant accepted practices. See section 2 for additional information and other considerations.

## 1.2 Equipment Description

**Table 1-1 TSO-Certified Units**

Model	P/N	NAV Receiver	TX Power (Watt)	8.33 kHz Spacing	25 kHz Spacing	Notes
GTR 225	011-02718-00	N/A	10	N/A	Yes	
GTR 225A	011-02807-00	N/A	10	Yes	Yes	
GTR 225B	011-02808-00	N/A	16	Yes	Yes	
	011-02808-20	N/A	16	Yes	Yes	NVIS-B Compatible
GNC 255A	011-02806-00	Yes	10	Yes	Yes	
GNC 255B	011-02719-00	Yes	16	Yes	Yes	
	011-02719-20	Yes	16	Yes	Yes	NVIS-B Compatible

The GTR 225 and GNC 255 Series units are a family of 6.25" wide, 1.65" tall panel-mounted VHF COM and NAV/COM radios.

The GTR 225 Series include an airborne VHF communications transceiver. The GTR 225 Series meet the requirements of the TSOs specified in table 1-10. A summary of system functions is located in table 1-11 and operating instructions are found in *GTR 225/GTR 225A/GTR 225B Pilot's Guide*. Differences between the GTR 225 models are listed in table 1-1.

The GNC 255 Series include all the features of the GTR 225 Series in addition to airborne VOR/localizer (LOC) and glideslope (G/S) receivers. The GNC 255 Series meet the requirements of the TSOs specified in table 1-10. A summary of system functions is located in table 1-11 and operating instructions are found in *GNC 255A/GNC 255B Pilot's Guide*. Differences between the GNC 255 models are listed in table 1-1.

**CAUTION**

*The GTR/GNC units have a display that is coated with a special anti-reflective coating that is very sensitive to waxes and abrasive cleaners. **CLEANERS CONTAINING AMMONIA WILL HARM THE ANTI-REFLECTIVE COATING.** It is very important to clean the display using a clean, lint-free cloth and an eyeglass lens cleaner that is specified as safe for anti-reflective coatings.*

**CAUTION**

*The use of ground-based cellular telephones while aircraft are airborne is prohibited by FCC rules. Due to potential interference with onboard systems, the use of ground-based cell phones while the aircraft is on the ground is subject to FAA regulation 14 CFR §91.21. FCC regulation 47 CFR §22.925 prohibits airborne operation of ground-based cellular telephones installed in or carried aboard aircraft. Ground-based cellular telephones must not be operated while aircraft are off the ground. When any aircraft leaves the ground, all ground-based cellular telephones on board that aircraft must be turned off. Ground-based cell phones that are on, even in a monitoring state, can disrupt GPS/SBAS performance.*

**NOTE**

*All screen shots used in this document are current at the time of publication. Screen shots are intended to provide visual reference only. All information depicted in screen shots, including software file names, versions, and part numbers, is subject to change and may not be up to date.*

### 1.3 General Specifications

**Table 1-2 Physical Specifications**

Characteristics	Specifications
Bezel height	1.65" (41.9 mm)
Bezel width	6.25" (158.8 mm)
Rack height (dimple-to-dimple)	1.72" (43.82 mm)
Rack width	6.30" (160.02 mm)
Depth behind panel with connectors (measured from face of aircraft panel to rear of connector backshells)	11.23"
GTR 225 weight (unit only)	2.36 lbs (1.07 kg)
GNC 255 weight (unit only)	3.02 lbs (1.37 kg)
GTR 225 installed with rack and connectors	3.06 lbs (1.39 kg)
GNC 255 installed with rack and connectors	3.96 lbs (1.80 kg)
Operating temperature range	-20°C to +55°C For more details refer to the environmental qualification forms at Garmin's <a href="#">Dealer Resource Center</a> . See appendix A for form part numbers.
Humidity	95% non-condensing
Altitude range	-1,500 ft to 55,000 ft
Input voltage range (COM connector)	9 to 33 VDC
Input voltage range (NAV connector)	9 to 33 VDC
Current draw	See table 1-9
Superflag power requirements	320 mA maximum per superflag output
Environmental testing	For more details refer to the environmental qualification forms at Garmin's <a href="#">Dealer Resource Center</a> . See appendix A for form part numbers.

**Table 1-3 Display Specifications**

The display on the GTR/GNC is a sunlight readable LCD display.

Characteristics	Specifications
Display size	Width: 3.46" (88.0 mm) Height: 0.843" (21.4 mm)
Active area	Width: 2.95" (74.98 mm) Height: 0.486" (12.36 mm)
Resolution	200 x 33 pixels
Viewing angles (Direction of pilot's viewing angle)	Left: 45° Right: 45° From Top: 30° From Bottom: 10°

## 1.4 COM Specifications

**Table 1-4 COM Transmitter Specifications**

Characteristics	Specifications
Classes	3, 4, 5, 6
Microphone input	Two inputs, standard carbon or dynamic mic with integrated preamp providing minimum 70 mVRMS into 1000 $\Omega$ load
Modulation capability	85% with 100 to 1000 mVRMS microphone input at 1000 Hz
Modulation	AM double sided Emission designator: 6K00A3E (118 - 136.975 MHz) 5K60A3E (118 - 136.992 MHz)
Frequency range	118.000 to 136.975 MHz, 25 kHz channel spacing 118.000 to 136.992 MHz, 8.33 kHz channel spacing
Frequency tolerance	+/-2 ppm from -40°C to +70°C
Output power	10 watt mode: 10 watts minimum 16 watt mode: 16 watts minimum
Duty cycle	10 W: 100% 16 W: Recommended 25% (5 seconds on/15 seconds off, 15 seconds on/45 seconds off, etc.)
Carrier noise level	At least 35 dB (SNR)
Stuck mic time-out	30 seconds time-out, reverts to receive
Demodulated audio distortion	Less than 5% distortion when the transmitter is at 85% modulation at 350 to 2500 Hz
Sidetone	1.4 Vrms into a 500 $\Omega$ load

**Table 1-5 COM Receiver Specifications**

Characteristics	Specifications
Classes	C, E, H1, and H2
Frequency range	118.000 to 136.975 MHz, 25 kHz channel spacing 118.000 to 136.992 MHz, 8.33 kHz channel spacing
Headset audio output	100 mW minimum into a 500 $\Omega$ load
Speaker audio output	12 W into 4 $\Omega$
Audio response	Less than 6 dB of variation between 350 and 2500 Hz
Audio distortion	Less than 5% at rated output power
Automatic gain control (AGC) characteristics	Less than 3 dB of variation in the audio output from -93 to -13 dBm (power absorbed by a 50 $\Omega$ load)
Sensitivity	SINAD on all channels is greater than 6 dB when the RF level is 2 $\mu$ V (hard) or -107 dBm (power absorbed by a 50 $\Omega$ load) modulated 30% at 1000 Hz at rated audio output power
Squelch	Automatic squelch with manual override
Selectivity	6 dB BW is greater than $\pm 7$ kHz for 25 kHz channeling 60 dB BW is less than $\pm 22$ kHz for 25 kHz channeling 6 dB BW is greater than $\pm 3.5$ kHz for 8.33 kHz channeling 60 dB BW is less than $\pm 7.37$ kHz for 8.33 kHz channeling
Maximum audio output reduction (offset carrier operation)	11.2 dB



## 1.5 VOR Specifications

**Table 1-6 VOR Specifications**

Characteristics	Specifications
Receiver audio sensitivity	At -103.5 dBm (S+N)/N is not less than 6 dB
Course deviation sensitivity	-103.5 dBm or less for 60% of standard deflection
Flag	<p>The VOR Course Deviation Flag indicates in the event of any of the following conditions:</p> <ul style="list-style-type: none"> <li>• Absence of RF signals</li> <li>• Absence of 9960 Hz modulation</li> <li>• Absence of either 30 Hz modulations</li> <li>• The RF level of a standard VOR deviation test signal is such that the deflection of the deviation indicator is less than a 50% of standard deflection</li> </ul>
AGC characteristics	From -99 dBm to -13 dBm input of a standard VOR audio test signal, audio output level does not vary more than 3 dB
Spurious response	Greater than 60 dB
VOR OBS bearing accuracy	The bearing information as presented to the pilot does not have an error in excess of 2.7° as specified by RTCA DO-196 and EuroCAE ED-22B
Audio output	A minimum 100 mW into a 500 Ω load
Deflection response	0.5 to 2.7 seconds
Audio response	<p>Less than 6 dB of variation between 350 and 2500 Hz</p> <p>In voice mode, an IDENT tone of 1020 Hz Ident Tone is attenuated at least 20 dB down</p>
Audio distortion	The distortion in the receiver audio output does not exceed 10% at all levels up to 100 mW

## 1.6 LOC Specifications

**Table 1-7 LOC Specifications**

Characteristics	Specifications
Receiver audio sensitivity	At -103.5 dBm (S+N)/N is not less than 6 dB
Course deviation sensitivity	At -103.5 dBm, deviation output is not to be less than 60% of standard deflection when a LOC deviation test signal is applied
Flag	<p>The LOC Course Deviation Flag indicates in the event of any of the following conditions:</p> <ul style="list-style-type: none"> <li>• The RF level of a standard LOC deviation test signal is such that the deflection of the deviation indicator is less than 50% of the standard deflection</li> <li>• Absence of 150 Hz modulation</li> <li>• Absence of 90 Hz modulation</li> <li>• Absence of both 90 Hz and 150 Hz modulations</li> <li>• Absence of RF signals</li> </ul>
AGC characteristics	From -99 dBm to -13 dBm input of a standard localizer audio test signal, audio output level does not vary more than 3 dB
Selectivity	<p>6 dB BW is greater than 9 kHz</p> <p>69 dB BW is less than 36 kHz</p>
Standard deflection	<p>With a standard deflection FLY LEFT condition (90 Hz dominant), the output is +90 mV <math>\pm</math> 9 mV.</p> <p>With a standard deflection FLY RIGHT condition (150 Hz dominant), the output is -90 mV <math>\pm</math> 9 mV</p>
Spurious response	Greater than 60 dB
Centering accuracy	0 $\pm$ 0.01023 ddm or 0 $\pm$ 9.9 mV
Audio output	A minimum 100 mW into a 500 $\Omega$ load
Audio response	<p>Less than 6 dB of variation between 350 and 2500 Hz</p> <p>In voice mode, an IDENT tone of 1020 Hz Ident Tone is attenuated at least 20 dB down</p>
Audio distortion	The distortion in the receiver audio output does not exceed 10% at all levels up to 100 mW

## 1.7 Glideslope Specifications

**Table 1-8 Glideslope Specifications**

Characteristics	Specifications
Sensitivity	-87 dBm or less for 60% of standard deflection
Centering accuracy	0 ±0.01183 ddm or 0 ±10.14 mV
Selectivity	<p>The course deviation is 0 ddm, .0091 ddm when using the glideslope centering test signal as the RF frequency is varied ±17 kHz from the assigned channel</p> <p>At frequencies displaced by ±132 kHz or greater, the input signal is at least 60 dB down</p>
Standard deflection	<p>With a standard deflection FLY DOWN condition (90 Hz dominant), the output is -78 mV ±7.8 mV</p> <p>With a standard deflection FLY UP condition (150 Hz dominant), the output is +78 mV ±7.8 mV</p>
Flag	<p>The unit flags in the event of any of the following conditions:</p> <ul style="list-style-type: none"> <li>• The RF level of a standard glideslope deviation test signal is such that the deflection of the deviation indicator is less than 50% of the standard deflection</li> <li>• Absence of 150 Hz modulation</li> <li>• Absence of 90 Hz modulation</li> <li>• Absence of both 90 Hz and 150 Hz modulations</li> <li>• Absence of RF signals</li> </ul>

## 1.8 Current Draw Specifications

Table 1-9 GTR/GNC Current Draw Specifications

LRU	14 Volt Current Draw		28 Volt Current Draw	
	Typical	Maximum	Typical	Maximum
<b>GTR 225</b>				
COM connector	0.59 A	4.2 A	0.28 A	1.9 A
<b>GTR 225A</b>				
COM connector	0.59 A	4.2 A	0.28 A	1.9 A
<b>GTR 225B</b>				
COM connector	0.59 A	5.9 A	0.28 A	2.6 A
<b>GNC 255A</b>				
COM connector	0.59 A	4.2 A	0.28 A	1.9 A
NAV connector	0.60 A	1.16 A	0.30 A	0.58 A
<b>GNC 255B</b>				
COM connector	0.59 A	5.9 A	0.28 A	2.6 A
NAV connector	0.60 A	1.16 A	0.30 A	0.58 A

### NOTES

- [1] The specified current draw is with the display backlight set to 100% and the fan operating. If the superflags are connected, their current draw must be added in addition to the specified current.
- [2] The specified current draw does not include the superflags. If connected, their current draw must be added to the specified current. The superflags will supply up to 320 mA each regardless of the input voltage.

## 1.9 License Requirements

The Telecommunications Act of 1996, effective February 8, 1996, provides the Federal Communications Commission (FCC) discretion to eliminate radio station license requirements for aircraft and ships. GTR/GNC installations must comply with current transmitter licensing requirements. In the US, to find out the specific details on whether a particular installation is exempt from licensing, please visit the FCC website <http://wireless.fcc.gov/aviation>. If an aircraft license is required, make application for a license on FCC form 404, Application for Aircraft Radio Station License. The FCC also has a fax-on-demand service to provide forms by fax. Outside the US, contact the responsible telecommunication authority. The GTR/GNC owner accepts all responsibility for obtaining the proper licensing before using the transceiver. The maximum transmitting power, modulation identification, and frequency band information may be required for licensing, see section 1.4.4.



### **CAUTION**

*The VHF transmitter in this equipment is guaranteed to meet FCC acceptance over the operating temperature range. Modifications not expressly approved by Garmin could invalidate the license and make it unlawful to operate the equipment.*

## 1.10 Certification

The GTR/GNC has been shown to meet compliance with the claimed TSO(s) when interfaced with the equipment defined in this manual, and installed in accordance with the requirements and limitations as defined in this manual.

The installer should verify non-Garmin devices, which are to be interfaced with the GTR/GNC, meet the installation requirements identified in this manual to assure the installed system will comply with the Garmin TSO/ETSO authorization. Garmin installation requirements will specify the interfaced device has appropriate TSO/ETSO authorization. In some cases, the non-Garmin device may also be required to meet additional Garmin specifications.

The Appliance Project Identifier (API) for the GTR/GNC is GMN-00999. The API is for project identification with the FAA and EASA. In addition, the alpha character appended to the API in the ETSO certificate is added to supplement project identification by EASA. This alpha character does not represent a version number. See applicable hardware and software part numbers to identify appliance approvals.

**Table 1-10 TSO Authorization and Advisory Circular References**

[1]					Function	TSO/ ETSO/ SAE/ RTCA/ EUROCAE	Class/Type	Applicable SW P/Ns	Applicable CLD P/Ns
GTR 225	GTR 225A	GTR 225B	GNC 255A	GNC 255B					
			C	C	ILS glideslope	TSO-C34e DO-192 ETSO-2C34f ED-47B		006-B0082-12 through -1( ) 006-B1374-03 through -0( )	006-C0124-01 through -0( )
			C	C	ILS localizer	TSO-C36e DO-195 ETSO-2C36f ED-46B	A	006-B0082-12 through -1( ) 006-B1374-03 through -0( )	006-C0124-01 through -0( )
			C	C	VOR	TSO-C40c DO-196 ETSO2C40c ED-22B		006-B0082-12 through -1( ) 006-B1374-03 through -0( )	006-C0124-01 through -0( )
C [2]	C	C	C	C	Equipment that prevent blocked channels	TSO-C128a DO-207 ETSO-2C128 ED-67		006-B1061-05 through -0( ) 006-B1374-03 through -0( )	006-C0135-23 through -2( )
C [2]	C	C	C	C	COM transceiver	TSO-C169a DO-186B ETSO-2C169a ED-23C	3, 4, 5, 6 C, E, H1, H2	006-B1061-05 through -0( ) 006-B1374-03 through -0( )	006-C0135-23 through -2( )

[1] C - Complete TSO  
I - Incomplete TSO

[2] ETSO-2C128 and ETSO-2C169a are not applicable to the GTR 225.

**Table 1-11 System Functions**

System Function	DO-178B/ED-12B Level	DO-254/ED-80 Level
Communication system	B	B
Display of VOR and ILS/LOC navigation	B	B
Display of DME navigation information	B	B
Display of database information	B	N/A

### 1.10.1 Non-TSO Functions

There are no non-TSO functions.

### 1.10.2 TSO Deviations

TSO/ETSO	Deviation
TSO-C34e	1. Garmin was granted a deviation from the TSO not to mark TSO number and software part number on the exterior of the unit.
	2. Garmin was granted a deviation from the TSO to use RTCA/DO-160F instead of an earlier version as the standard for environmental conditions and test.
	3. Garmin was granted a deviation from the TSO to use RTCA/DO-178B instead of an earlier version to demonstrate compliance for the verification and validation of the computer software.
TSO-C36e	1. Garmin was granted a deviation from the TSO not to mark TSO number and software part number on the exterior of the unit.
	2. Garmin was granted a deviation from the TSO to use RTCA/DO-160F instead of an earlier version as the standard for environmental conditions and test.
	3. Garmin was granted a deviation from the TSO to use RTCA/DO-178B instead of an earlier version to demonstrate compliance for the verification and validation of the computer software.
TSO-C40c	1. Garmin was granted a deviation from the TSO not to mark TSO number and software part number on the exterior of the unit.
	2. Garmin was granted a deviation from the TSO to use RTCA/DO-160F instead of an earlier version as the standard for environmental conditions and test.
	3. Garmin was granted a deviation from the TSO to use RTCA/DO-178B instead of an earlier version to demonstrate compliance for the verification and validation of the computer software.
ETSO-2C40c	1. Garmin was granted a deviation from the ETSO to have a deflection response of 0.5 to 2.7 seconds.
TSO-C128a	1. Garmin was granted a deviation from the TSO not to mark TSO number and software part number on the exterior of the unit.
	2. Garmin was granted a deviation from the TSO to use RTCA/DO-160F instead of an earlier version as the standard for environmental conditions and test.
TSO-C169a	1. Garmin was granted a deviation from the TSO not to mark TSO number and software part number on the exterior of the unit.
	2. Garmin was granted a deviation from the TSO to use RTCA/DO-160F instead of an earlier version as the standard for environmental conditions and test.

### 1.10.3 FCC Grant of Equipment Authorization

Model	FCC ID	IC ID
GTR 225	IPH-01594	1312A-01594
GTR 225A		
GTR 225B		
GNC 255A		
GNC 255B		

## 1.11 GTR/GNC Database

The GTR/GNC has a database of frequencies for airports and VORs. GTR/GNC users update the frequency database by purchasing database subscription updates from Garmin. The frequency database is stored internally and uses a USB flash drive to transfer the database into the unit. Refer to the applicable GTR or GNC pilot's guide, contact Garmin at (866) 739-5687, or go to [flyGarmin.com](http://flyGarmin.com) for more information and instructions.

The GTR/GNC database has no safety effect, and does not claim compliance with RTCA/DO-200A Standards for Processing Aeronautical Data.

Garmin requests that the flight crew report any observed discrepancies related to database information. These discrepancies could come in the form of an incorrect frequency, incorrectly identified airport, VOR, or other station, or any other displayed item used for navigation or communication in the air or on the ground. Go to [flyGarmin.com](http://flyGarmin.com) and select “Aviation Data Error Report.”



## 1.12 Aviation Limited Warranty

All Garmin avionics products are warranted to be free from defects in materials or workmanship for: two years from the date of purchase for new Remote-Mount and Panel-Mount products; one year from the date of purchase for new portable products and any purchased newly-overhauled products; six months for newly-overhauled products exchanged through a Garmin Authorized Service Center; and 90 days for factory repaired or newly-overhauled products exchanged at Garmin in lieu of repair. Within the applicable period, Garmin will, at its sole option, repair or replace any components that fail in normal use. Such repairs or replacement will be made at no charge to the customer for parts or labor, provided that the customer will be responsible for any transportation cost. This warranty does not apply to: (i) cosmetic damage, such as scratches, nicks and dents; (ii) consumable parts, such as batteries, unless product damage has occurred due to a defect in materials or workmanship; (iii) damage caused by accident, abuse, misuse, water, flood, fire, or other acts of nature or external causes; (iv) damage caused by service performed by anyone who is not an authorized service provider of Garmin; or (v) damage to a product that has been modified or altered without the written permission of Garmin. In addition, Garmin reserves the right to refuse warranty claims against products or services that are obtained and/or used in contravention of the laws of any country.

THE WARRANTIES AND REMEDIES CONTAINED HEREIN ARE EXCLUSIVE AND IN LIEU OF ALL OTHER WARRANTIES, WHETHER EXPRESS, IMPLIED OR STATUTORY, INCLUDING ANY LIABILITY ARISING UNDER ANY WARRANTY OF MERCHANTABILITY OR FITNESS FOR A PARTICULAR PURPOSE, STATUTORY OR OTHERWISE. THIS WARRANTY GIVES YOU SPECIFIC LEGAL RIGHTS, WHICH MAY VARY FROM STATE TO STATE.

IN NO EVENT WILL GARMIN BE LIABLE FOR ANY INCIDENTAL, SPECIAL, INDIRECT OR CONSEQUENTIAL DAMAGES, WHETHER RESULTING FROM THE USE, MISUSE OR INABILITY TO USE THE PRODUCT OR FROM DEFECTS IN THE PRODUCT. SOME STATES DO NOT ALLOW THE EXCLUSION OF INCIDENTAL OR CONSEQUENTIAL DAMAGES, SO THE ABOVE LIMITATIONS MAY NOT APPLY TO YOU.

Garmin retains the exclusive right to repair or replace (with a new or newly-overhauled replacement product) the product or software or offer a full refund of the purchase price at its sole discretion. SUCH REMEDY WILL BE YOUR SOLE AND EXCLUSIVE REMEDY FOR ANY BREACH OF WARRANTY.

**Online Auction Purchases:** Products purchased through online auctions are not eligible for warranty coverage. Online auction confirmations are not accepted for warranty verification. To obtain warranty service, an original or copy of the sales receipt from the original retailer is required. Garmin will not replace missing components from any package purchased through an online auction.

**International Purchases:** A separate warranty may be provided by international distributors for devices purchased outside the United States depending on the country. If applicable, this warranty is provided by the local in-country distributor and this distributor provides local service for your device. Distributor warranties are only valid in the area of intended distribution. Devices purchased in the United States or Canada must be returned to the Garmin service center in the United Kingdom, the United States, Canada, or Taiwan for service.

## **2 LIMITATIONS**

### **2.1 Installation**

Conditions and tests required for TSO approval of this article are minimum performance standards. It is the responsibility of those installing this article either on or within a specific type or class of aircraft to determine that the aircraft installation conditions are within the TSO standards. TSO articles must have separate approval for installation in an aircraft. The article may be installed only if performed under 14 CFR Part 43 or the applicable airworthiness requirements.

To mitigate against the loss of navigation and communication, installation of a second navigation and/or communication system may be required.

### **2.2 Aircraft Radio**

An aircraft radio station license is not required when operating in U.S. airspace, but may be required when operating internationally.

As required by TSO-C169a, the quantitative safety objective for the VHF COM radio in the GTR/GNC is  $1 \times 10^{-4}$  per flight hour for Class I Part 23 airplanes, and  $1 \times 10^{-5}$  per flight hour for all other Part 23 and Part 27 aircraft. To meet requirements for Part 23 Class II, Class III and Class IV, and Part 27 aircraft, it may be necessary to install a second VHF communications radio.

## 3 INSTALLATION OVERVIEW

### 3.1 Introduction

Always follow acceptable avionics installation practices per AC 43.13-1B, AC 43.13-2B, or later FAA approved revisions of these documents. The communications installation instructions have been prepared to meet the guidance material defined by AC 20-67B, *Airborne VHF Communications Equipment Installations*.

### 3.2 Antenna Considerations

Considerations for the mounting location of the antennas required for the GTR/GNC is provided in this section. For mounting the COM and NAV antennas, refer to the aircraft manufacturer's data.

#### 3.2.1 COM Antenna Location

The GTR/GNC COM antenna should be installed away from all projections, engines and propellers. The ground plane surface directly below the antenna should be a flat plane over as large an area as possible (18" square, minimum). The antenna should be mounted a minimum of six feet from any DME or other COM antennas, and four feet from any ADF sense antennas. The COM antenna should also be mounted as far apart as practical from the ELT antenna. Some ELTs have exhibited re-radiation problems that cause interference with other radios, including GPS. This can happen when the COM (GTR/GNC or any other COM) is transmitting on certain frequencies such as 121.15 or 121.175 MHz, which may cause the ELT output circuit to oscillate from the signal coming in on the ELT antenna coax.

If simultaneous use of two COM transceivers is desired (split-COM or simul-COM), the COM antennas should be spaced for maximum isolation. A configuration of one topside antenna and one bottom side antenna is recommended. The GTR/GNC does not require a transmit interlock, but other COM radios such as the GNS 530W may require it for split-COM operations.



#### NOTE

*Canadian installations are required to meet Industry Canada specifications for maximum radiation as documented in Radio Specifications Standard 102 (RSS-102). For more information about RF exposure and related Canadian regulatory compliance, contact:*

*Manager, Radio Equipment Standards  
Industry Canada  
365 Laurier Avenue  
Ottawa, Ontario  
K1A 0C8*

*In accordance with Canadian Radio Specifications Standard 102 (RSS 102), RF field strength exposure to persons from an antenna connected to this device should be limited to 60V/m for controlled environment and 28 V/m for uncontrolled environment.*

### 3.2.2 Interference of GPS

On some installations, VHF COM transceivers, Emergency Locator Transmitter (ELT) antennas, and Direction Finder (DF) receiver antennas can re-radiate through the GPS antenna. Placement of the GPS antenna relative to a COM transceiver and COM antenna (including the GTR/GNC COM antenna), ELT antenna, and DF receiver antenna is critical.

Use the following guidelines, in addition to others in this document, when locating the GTR/GNC and its antennas.

- Locate the GTR/GNC as far as possible from all GPS antennas
- Locate the COM antenna as far as possible from all GPS antennas

If a COM antenna is found to be the problem, a 1.57542 GHz notch filter (see table 4-3) may be installed in the VHF COM coax, as close to the COM as possible. This filter is not required for the GTR/GNC transmitter.

If a COM is found to be radiating, the following can be done:

- Replace or clean VHF COM rack connector to ensure good coax ground
- Place a grounding brace between the GTR/GNC, VHF COM and ground
- Shield the VHF COM wiring harness

### 3.3 GTR/GNC Mounting Considerations

The GTR/GNC is designed to mount in the avionics stack in the aircraft instrument panel within view and reach of the pilot. The primary unit location should minimize pilot head movement when transitioning between looking outside of the cockpit and viewing/operating the GTR/GNC. The location should be such that the GTR/GNC unit is not blocked by the glare shield on top, or by the throttles, control yoke, etc., on the bottom. If aircraft has a throw-over yoke, be sure the yoke does not interfere with the GTR/GNC.

### 3.4 Cabling and Wiring Considerations

Wiring should be installed in accordance with AC 43.13-1B Chapter 11. For dual GTR/GNC unit installations, care should be taken to ensure separation between wires of redundant systems to reduce the possibility of loss of navigation due to a single event. When wire separation cannot be achieved, the following issues should be addressed:

- It should not be possible for a cable harness to be exposed to wire chafing in a manner that both units fail simultaneously;
- The cable harness should not be located near flight control cables and controls, high voltage lines or fuel lines;
- The cable harness should be located in a protected area of the aircraft (e.g., isolated from engine rotor burst); and
- Do not route cable near high voltage sources.



#### NOTE

*Pigtail lengths should be less than 3.0". Wiring which is required to be shielded must be shielded per appendix D.*

See section 4.4.2 and section 4.5 for connector and tooling information.

See section 4.6 for recommended coax cable.

See appendix D for the appropriate wiring connections to assemble the wiring connector.

Once the cable assemblies have been made, attach the cable connectors to the rear connector plate. After installing the mounting tube, attach the assembled connector plate. Route the wiring bundle as appropriate. Use 22 or 24 AWG wire for all connections. For power and ground, use the wire gauge specified in the interconnect drawing, then 22 AWG for the short length from the splice to the connector. Avoid sharp bends.

### 3.5 Air Circulation and Cooling

The GTR/GNC unit meets all requirements without external cooling. However, as with all electronic equipment, lower operating temperatures extend equipment life.

Units packed tightly in the avionics stack heat each other through radiation, convection, and sometimes by direct conduction. Even a single unit operates at a much higher temperature in still air than in moving air.

The GTR/GNC has a cooling fan integrated into the chassis to draw forced-air cooling through the unit. There are inlets along the right side of the GTR/GNC chassis that allow air to flow through the unit. Ensure that there are no obstructions to the air inlets or fan exhausts. Air should be able to freely flow from the chassis inlets to the fan outlet on the rear of the unit.

### 3.6 Compass Safe Distance

After reconfiguring the avionics in the cockpit panel, if the GTR/GNC unit is mounted less than twelve inches from the compass, recalibrate the compass and make the necessary changes for noting correction data.

## 4 INSTALLATION PROCEDURES

### 4.1 Unit and Accessories

For description of units see table 1-1.

**Table 4-1 Catalog P/Ns**

Model	Unit Only Kit	Standard Kit	Unit P/N
GTR 225	010-00998-00	010-00998-50	011-02718-00
GTR 225A	010-01026-00	010-01026-50	011-02807-00
GTR 225B	010-01027-00	010-01027-50	011-02808-00
	010-01027-20	010-01027-70	011-02808-20 [1]
GNC 255A	010-01025-00	010-01025-50	011-02806-00
GNC 255B	010-00999-00	010-00999-50	011-02719-00
	010-00999-20	010-00999-70	011-2719-20 [1]

[1] Unit is NVIS-B compatible.

**Table 4-2 Standard Kit Accessories**

Model	Item	P/N
GTR 225/225A/225B	Connector kit	011-02721-00
	Backplate assembly	011-02722-00
	Mounting rack	115-01613-00
	Product information kit	K00-00554-10
GNC 255A/GNC 255B	Connector kit	011-02721-10
	Backplate assembly	011-02722-10
	Mounting rack	115-01613-00
	Product information kit	K00-00554-20

### 4.2 Miscellaneous Options

**Table 4-3 Miscellaneous Options**

Item	Garmin P/N	Manufacturer P/N
GPS 1.57542 GHz notch filter	330-00067-00	N/A
Connector, TNC, male, clamp	N/A	031-4452 [1]

[1] This part is not available from Garmin.

Vendor Contact Information (provided for convenience only):

Amphenol RF, Four Old Newtown Road, Danbury, CT 06810 Phone: (800) 627-7100

### 4.3 Optional Reference Material

**Table 4-4 Optional Reference Material**

Item	Garmin P/N
<i>GDU 620 Installation Manual</i>	190-00601-04
<i>GNC 255A/255B Pilot's Guide</i>	190-01182-01
<i>GTR 225/225A/225B Pilot's Guide</i>	190-01182-00

### 4.4 Installation Materials Required but not Supplied

#### 4.4.1 Accessories Required but Not Supplied

The following installation accessories are required but not provided.

Item	Requirements
COM antenna	Meets TSO-C37( ) and C38( ) <b>or</b> TSO-C169( ) 50 $\Omega$ , vertically polarized with coaxial cable
NAV antenna	Meets TSO C40( ) and C36( ). 50 $\Omega$ , horizontally polarized with coaxial cable If the NAV antenna is a combined VOR/LOC/GS antenna, it must meet TSO C40( ), C36( ), and C34( )
Glideslope antenna	Meets TSO C34( ). 50 $\Omega$ , horizontally polarized with coaxial cable or low-loss splitter used with the VOR/LOC antenna
Headphones	500 $\Omega$ nominal impedance
Microphone	Low impedance, carbon or dynamic, with transistorized pre-amp

#### 4.4.2 Materials Required but Not Supplied (New Installations Only)

The GTR/GNC is intended for use with the standard aviation accessories. The following items are required for installation, but not supplied:

- Wire (MIL-W-22759/16 or equivalent)
- Shielded wire (MIL-C-27500 or equivalent)
- Hardware
  - #6-32 x 100° flat head SS screw (MS24693, AN507R or other approved fastener (6 ea.))
  - #6-32 self-locking nut (MS21042 or other approved fastener (6 ea.))
- Push/pull (manually resettable) circuit breakers
- Tie wraps or lacing cord
- Ring terminals (for grounding)
- Coaxial cable (RG-400, RG-142B or equivalent. See table 4.8 for additional information)

## 4.5 Special Tools Required

Some of the connectors use crimp contacts. The table below identifies crimp tools required to ensure consistent, reliable crimp contact connections for the rear D-sub connectors.

**Table 4-5 Recommended Crimp Tools (or Equivalent)**

Manufacturer	Hand Crimping Tool	22 – 28 AWG (P2001 – P2002)	
		Positioner	Insertion/ Extraction Tool
Military P/N	M22520/2-01	M22520/2-09	M81969/14-01 M81969/1-04
Positronic	9507-0-0-0	9502-4-0-0	M81969/1-04
ITT Cannon	995-0001-584	995-0001-739	000849490 274-7048-000MIL
AMP	601966-1	601966-6	91067-1 2031838-1
Daniels	AFM8	K42	M81969/14-01 M81969/1-04
Astro	615717	615725	M81969/14-01 M81969/1-04



### NOTE

*Insertion/extraction tools from ITT Cannon are all plastic; others are plastic with metal tip.*

**Table 4-6 Socket Contact P/Ns**

Wire Gauge	P2001-P2002
	22-28 AWG
Garmin P/N	336-00021-00
Military P/N	M39029/58-360 [1]

[1] Non-Garmin part numbers shown are not maintained by Garmin and are subject to change without notice.



## 4.6 Coaxial Cable Installation

Follow the steps below for installation of the coaxial cables:

1. Route the coaxial cable to the radio rack location keeping in mind the recommendations of section 3.2. Secure the cable in accordance with AC 43.13-1B chapter 11, section 11.
2. Trim the coaxial cable to the desired length and install the coaxial connectors per the manufacturer's instructions.

## 4.7 Equipment Mounting

### 4.7.1 Rack Installation

Use the dimensions shown in figure C-1 to prepare the mounting holes for the GTR/GNC unit. The GTR/GNC unit mounting rack may be used as a template for drilling the mounting holes.

1. Install the rack in a rectangular 6.32" x 1.77" hole (or gap between units) in the instrument panel. The lower-front lip of the rack should be flush with, or extend slightly beyond, the finished aircraft panel.



#### NOTE

*If the front lip of the mounting rack is behind the surface of the aircraft panel, the GTR/GNC unit connectors may not fully engage. See figure C-7 for more information. Ensure that no screw heads or other obstructions prevent the unit from fully engaging in the rack, see section 6.3. When installing the rack into the instrument panel, deformation of the rack may make it difficult to install and remove the GTR/GNC unit.*

2. Install the rack in the aircraft panel using six #6-32 flat head screws and six self-locking nuts. The screws are inserted from the inside through the holes in the sides of the rack.
3. To attach the backplate to the rack, align the backplate so that the backplate screw heads pass through the keyed holes in the back of the rack.
4. Slide the backplate to the right (viewing from cockpit) until it clicks into place.
5. Secure the backplate by tightening the four #4-40 screws.

## 4.7.2 GTR/GNC Unit Insertion and Removal



### NOTE

*Prior to placing the unit in the rack, in order to ensure correct position of the retention mechanism, it may be necessary to insert the hex drive tool into the access hole and turn the drive tool counterclockwise until it completely stops.*



### CAUTION

*The application of hex drive tool torque exceeding 15 in-lbs can damage the locking mechanism.*

### **Insertion**

1. The GTR/GNC unit is installed in the rack by sliding it straight in until it stops, approximately 3/8 inch short of the final position.
2. Insert a 3/32" hex drive tool into the access hole at the bottom of the unit face.
3. Turn the hex tool clockwise while pressing on the left side of the bezel until the unit is seated in the rack.

### **Removal**

1. Insert the hex drive tool into the access hole on the unit face.
2. Turn hex drive tool counterclockwise until the hex drive tool stops.
3. Pull the unit from the rack.

## 4.7.3 Unit Replacement

Whenever the GTR/GNC unit is removed or reinstalled, verify that the unit powers up successfully.

## 4.8 COM Antenna Installation and Connections

The GTR/GNC unit requires a standard 50  $\Omega$  vertically polarized antenna. Follow the antenna manufacturer's installation instructions for mounting the antenna.

The antenna should be mounted on a metal surface or a ground plane with a minimum area of 18 inches by 18 inches. See section 3.2.1 for installation location considerations.

The antenna coax cable should be made of RG-142B, RG-400 or a comparable quality 50  $\Omega$  coax.

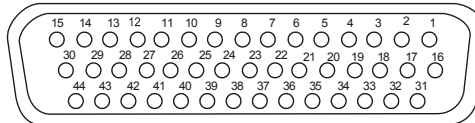
Check for insertion loss and voltage standing wave ratio (VSWR). VSWR should be checked with an in-line type VSWR/wattmeter inserted in the coaxial transmission line between the transceiver and the antenna. The VSWR should be inserted as close to the transceiver as possible. When rack and harness buildup is performed in the shop, the coax termination may be provisioned by using a 6" in-line BNC connection. This would be an acceptable place to insert the VSWR. Any problem with the antenna installation is most likely seen as high reflected power. A VSWR of 3:1 may result in up to a 50% loss in transmit power.

## 5 CONNECTOR PINOUT INFORMATION

### 5.1 Pin Function List

#### 5.1.1 J2001 Connector – COM Board

(View looking at rear of unit, Pin 1 is top right)



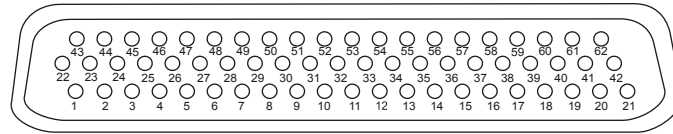
Pin	Pin Name	I/O
1	RS-232 OUT 1	Out
2	LIGHTING HI 2	In
3	AUX AUDIO LINE LEVEL HI	In
4	RESERVED	--
5	COM MIC 1 AUDIO IN HI	In
6	COM MIC 2 AUDIO IN HI	In
7	500 Ω COM AUDIO HI	Out
8	LIGHTING HI 1	In
9	RESERVED	--
10	RESERVED	--
11	COM MIC 1 KEY*	In
12	INTERCOM ENABLE*	In
13	SPEAKER OUT	Out
14	RESERVED	--
15	RESERVED	--
16	RS-232 IN 1	In
17	RESERVED	--
18	500 Ω COM AUDIO LO	--
19	AUX AUDIO LINE LEVEL GND	--
20	MIC AUDIO IN LO	In
21	RESERVED	--
22	LIGHTING LO 1	In
23	RESERVED	--
24	RESERVED	--
25	RESERVED	--
26	COM MIC 2 KEY*	In
27	COM REMOTE TRANSFER*	In
28	COM REMOTE TUNE UP*	In
29	COM REMOTE TUNE DOWN*	In
30	AIRCRAFT POWER	In
31	RS-232 GND	--
32	LIGHTING LO 2	In
33	RESERVED	--

Pin	Pin Name	I/O
34	RESERVED	--
35	RESERVED	--
36	RESERVED	--
37	AIRCRAFT GND	--
38	AIRCRAFT GND	--
39	SPEAKER GND	--
40	AIRCRAFT GND	--
41	RESERVED	--
42	RESERVED	--
43	AIRCRAFT POWER	In
44	AIRCRAFT POWER	In

An asterisk (\*) following a signal name denotes that the signal is an Active-Low, requiring a ground to activate. If there is no asterisk, the signal is an Active-High.

## 5.1.2 J2002 Connector – NAV Board

(View looking at rear of unit, Pin 1 is bottom left)



Pin	Pin Name	I/O
1	VOR/LOC +TO	Out
2	VOR/LOC +FROM	Out
3	VOR/LOC +FLAG	Out
4	VOR/LOC -FLAG	Out
5	VOR/LOC +LEFT	Out
6	VOR/LOC +RIGHT	Out
7	RESERVED	--
8	VOR/LOC COMPOSITE OUT	Out
9	VOR OBS ROTOR C	Out
10	VOR OBS ROTOR H (GND)	--
11	VOR OBS STATOR E (GND)	--
12	VOR OBS STATOR F	In
13	VOR OBS STATOR D	In
14	VOR OBS STATOR G (GND)	--
15	VOR/LOC SUPERFLAG	Out
16	500 Ω VOR/LOC AUDIO OUT HI	Out
17	500 Ω VOR/LOC AUDIO OUT LO	Out
18	SERIAL DME - CLOCK	I/O
19	SERIAL DME - DATA	I/O
20	SERIAL DME - RNAV/CH REQ	In
21	SERIAL DME - RNAV MODE	In
22	AIRCRAFT GND	In
23	VOR/ILS ARINC 429 OUT B	Out
24	VOR/ILS ARINC 429 OUT A	Out
25	VOR OBI CLOCK	Out
26	VOR OBI SYNC	Out
27	VOR OBI DATA	Out
28	VLOC REMOTE TRANSFER	In
29	ILS ENERGIZE	Out
30	SPARE	--
31	SPARE	--
32	GLIDESLOPE +FLAG	Out
33	PAR DME 1 MHZ-D/SERIAL DME ON	Out
34	GLIDESLOPE +UP	Out
35	RESERVED	--
36	RESERVED	--

Pin	Pin Name	I/O
37	PAR DME 100 kHz-A/SERIAL DME HOLD	Out
38	GLIDESLOPE SUPERFLAG	Out
39	PAR DME 100 kHz-B	Out
40	PAR DME 100 kHz-C	Out
41	DME COMMON	In
42	PAR DME 100 kHz-D	Out
43	PAR DME 50 kHz	Out
44	SERIAL DME - DME REQUEST	I/O
45	PAR DME 1 MHZ-A	Out
46	PAR DEM 1 MHZ-B	Out
47	PAR DME 1 MHZ-C	Out
48	RESERVED	--
49	AIRCRAFT GND	In
50	RESERVED	--
51	AIRCRAFT POWER	In
52	AIRCRAFT POWER	In
53	GLIDESLOPE - FLAG	Out
54	PAR DME 100 kHz-E	Out
55	GLIDESLOPE +DOWN	Out
56	PAR DME 1MHZ-E	Out
57	RESERVED	--
58	GLIDESLOPE COMPOSITE OUT	Out
59	RESERVED	--
60	AIRCRAFT GND	In
61	AIRCRAFT GND	In
62	AIRCRAFT GND	In

## 5.2 Power, Lighting, And Antennas

Information about power input requirements, lighting bus input, and antenna connections is provided in this section. See appendix D for interconnect information.

### 5.2.1 Power

Power inputs P2001-30, P2001-43, and P2001-44 provide power for the COM radio. All three pins must be connected.

Power inputs P2002-51 and P2002-52 provide power for the NAV radio. Both pins must be connected.

Pin Name	Connector	Pin	I/O
AIRCRAFT POWER	P2001	30	In
AIRCRAFT POWER	P2001	43	In
AIRCRAFT POWER	P2001	44	In
AIRCRAFT POWER	P2002	51	In
AIRCRAFT POWER	P2002	52	In
AIRCRAFT GROUND	P2001	37	In
AIRCRAFT GROUND	P2001	38	In
AIRCRAFT GROUND	P2001	40	In
AIRCRAFT GROUND	P2002	22	In
AIRCRAFT GROUND	P2002	49	In
AIRCRAFT GROUND	P2002	60	In
AIRCRAFT GROUND	P2002	61	In
AIRCRAFT GROUND	P2002	62	In

### 5.2.2 Lighting Bus



#### CAUTION

*Connection of the lighting bus to incorrect pins can cause damage to the unit that will require return to the factory for repair. Ensure that the lighting bus is connected to the correct pins and does not short to any adjacent pins prior to applying power to the unit, including the lighting bus.*

Pin Name	Connector	Pin	I/O
LIGHTING HI 1	P2001	8	In
LIGHTING HI 2	P2001	2	In
LIGHTING LO 1	P2001	22	In
LIGHTING LO 2	P2001	32	In

### 5.2.3 Antennas

The COM and NAV antennas use BNC coaxial connectors on the connector backplate.

Pin Name	Connector	I/O
COM ANTENNA	P2003	I/O
NAV ANTENNA	P2004	In

### 5.2.4 Serial Data – RS-232

Pin Name	Connector	Pin	I/O
RS-232 OUT 1	P2001	1	Out
RS-232 IN 1	P2001	16	In

#### 5.2.4.1 Aviation Out Type 1 and 2 Format

The GTR/GNC is capable of interfacing with other aviation instruments by receiving Aviation Out Type 2 data on RS-232 Input Port 1. See appendix B.1 for a detailed data format description. The data consists of the following information.



#### NOTE

*Aviation RS-232 data may be transmitted with or without the current GPS altitude in feet. See appendix B.*

- Current latitude, longitude, and GPS altitude in feet
- Current velocity vector (ground speed and direction of velocity vector over the ground)
- Distance to waypoint
- Cross track error
- Desired track
- Destination waypoint identifier
- Bearing to destination waypoint
- Magnetic variation
- Navigation and warning status
- Waypoint sequence in route
- Waypoint position (latitude and longitude) and magnetic variation



## 5.2.4.2 NMEA Format

### 5.2.4.2.1 Legacy NMEA Support

The GTR/GNC maintains backwards compatibility with legacy SL30/SL40 NMEA commands (\$PMMRC and \$PMMRV) as they apply to GTR/GNC functionality. See appendix B.2.

The following legacy SL30/40 input commands are supported as-is.

- Set active COM frequency (SL30 version – only in 25 kHz spacing mode)
- Set active frequency and transceiver function (SL40 version – only in 25 kHz spacing mode)
- Set standby COM frequency (SL30 version – only in 25 kHz spacing mode)
- Set standby frequency and transceiver function (SL40 version – only in 25 kHz spacing mode)
- Set Omni-Bearing Select (OBS) value
- Select squelch test (Squelch Override On/Off)

The following legacy SL30/40 input commands are supported with modifications to fit the GTR/GNC architecture.

- Set active VOR/LOC frequency: Set monitor mode ignored
- Set standby VOR/LOC frequency: Set monitor mode ignored
- Set NAV audio mode: Cannot turn off NAV audio
- Set volume level and audio control parameters: Only headphone, sidetone level, and RF squelch supported
- Request data output: Cannot set speed. Only unlisted command supported is request reset status in both versions

### 5.2.4.2.2 NMEA GPS Data

The following NMEA standard GPS messages are used by the GTR/GNC for position source.

- Geographic position, latitude/longitude (\$GPGLL)
- Track made good and ground speed (\$GPVTG)
- Recommended minimum GPS data (\$GPRMC) (display software version 2.10 or later)

### 5.2.4.2.3 Input Commands

The following input command messages are supported.

- Request data output
- Set active COM frequency
- Set standby COM frequency
- Set squelch override
- Set COM volume level and audio control parameters
- Set COM channel spacing
- COM keypad input (display software version 2.10 or later)
- Set active NAV frequency (GNC only)
- Set standby NAV frequency (GNC only)
- Set NAV audio mode (GNC only)
- Set omni-bearing select (OBS) value (GNC only)
- Set NAV volume level (GNC only)
- NAV keypad input (GNC only) (software version 2.10 or later)

### 5.2.4.3 COM Audio

#### 5.2.4.4 COM Audio Function

Activation of COM MIC 1 TRANSMIT enables MIC 1 AUDIO IN HI and causes the transceiver to transmit.

Activation of COM MIC 2 TRANSMIT enables MIC 2 AUDIO IN HI and causes the transceiver to transmit.

500  $\Omega$  COM AUDIO is a 100 mW audio output that is intended to drive a headset or an audio panel.

#### 5.2.4.5 COM Audio Electrical Characteristics

##### 5.2.4.5.1 COM MIC AUDIO

MIC 1 and MIC 2 are standard carbon or dynamic mic inputs with integrated preamps providing minimum 70 mVrms into a 1000  $\Omega$  load.

MIC 1 and MIC 2 are set in the factory so that 100 mVrms modulates the transmitter to 85% nominally at 1000 Hz. The microphone gain adjustment is made through configuration mode.

Pin Name	Connector	Pin	I/O
COM MIC 1 AUDIO IN HI	P2001	5	In
COM MIC 2 AUDIO IN HI	P2001	6	In
MIC AUDIO IN LO	P2001	20	In

##### 5.2.4.5.2 COM AUDIO

COM AUDIO supplies 100 mW into a 500  $\Omega$  load. This is a balanced output and the LO output must be connected.

COM AUDIO is the summation of the COM receiver audio, COM sidetone audio, and intercom audio.

Pin Name	Connector	Pin	I/O
500 $\Omega$ COM AUDIO HI	P2001	7	Out
500 $\Omega$ COM AUDIO LO	P2001	18	Out

## 5.2.5 COM Discrete Inputs

Active-Low discrete inputs are considered active if either the voltage to ground is  $\leq 3.5$  VDC or the resistance to ground is  $\leq 375 \Omega$ . These inputs are considered inactive if the voltage to ground is 6.5-33 VDC or the resistance to ground is  $> 100 \text{ k}\Omega$ .

Active-High discrete inputs are considered active if the voltage to ground is  $> 6.5$  VDC. These inputs are considered inactive if the voltage to ground is  $\leq 3.5$  VDC or the resistance to ground is  $\leq 375 \Omega$ .

Pin Name	Connector	Pin	I/O
COM MIC 1 KEY*	P2001	11	In
INTERCOM ENABLE*	P2001	12	In
COM MIC 2 KEY*	P2001	26	In
COM REMOTE TRANSFER*	P2001	27	In
COM REMOTE TUNE UP*	P2001	28	In
COM REMOTE TUNE DOWN*	P2001	29	In
TEST MODE*	P2001	41	In

An asterisk (\*) following a signal name denotes that the signal is an Active-Low, requiring a ground to activate. If there is no asterisk, the signal is an Active-High.

### 5.2.5.1 COM MIC 1 KEY\*

COM MIC 1 KEY\* discrete input, when pulled low, allows the audio that is present on the COM MIC 1 AUDIO IN HI (P2001-5) to be transmitted over the radio.

### 5.2.5.2 INTERCOM ENABLE\*

The INTERCOM ENABLE\* discrete input enables the intercom function of the GTR/GNC when grounded. This input can be connected to a switch, that, when activated, will enable the intercom function. There is also a menu option to enable the intercom if it is not desired to utilize a remote switch.

### 5.2.5.3 COM MIC 2 KEY\*

COM MIC 2 KEY\* discrete input, when pulled low, allows the audio that is present on the COM MIC 2 AUDIO IN HI (P2001-6) to be transmitted over the radio.

### 5.2.5.4 COM REMOTE TRANSFER\*

COM REMOTE TRANSFER\* discrete input may be used to flip-flop between the active and standby COM frequencies. A momentary low on this pin will load the standby COM frequency into the active COM frequency field and place the active frequency into the standby COM frequency field.

COM REMOTE TRANSFER\* input may be used for emergency operation of the COM transmitter. If the switch is depressed for two seconds, the active COM frequency changes to 121.500 MHz. Once the emergency frequency is activated through COM REMOTE TRANSFER\*, the GTR/GNC transceiver ignores inputs from the front panel controls for COM selections only. The pilot may exit this independent mode, restoring COM selection control to the front panel knobs and keys, by again depressing the switch for two seconds.

### 5.2.5.5 COM REMOTE TUNE UP\*

COM REMOTE TUNE UP\* discrete input may be used to scroll through a list of preset COM frequencies. A momentary low on this pin will load the next preset frequency in the list into the standby COM frequency field.

### 5.2.5.6 COM REMOTE TUNE DOWN\*

COM REMOTE TUNE DOWN\* discrete input may be used to scroll through a list of preset COM frequencies. A momentary low on this pin will load the previous preset frequency in the list into the standby COM frequency field.

### 5.2.6 VOR/ILS Audio

500  $\Omega$  VOR/LOC AUDIO OUT HI supplies 100 mW into a 500  $\Omega$  load. It is a balanced output and the 500  $\Omega$  VOR/LOC AUDIO OUT LO output must be connected.

Pin Name	Connector	Pin	I/O
500 $\Omega$ VOR/LOC AUDIO OUT HI	P2002	16	Out
500 $\Omega$ VOR/LOC AUDIO OUT LO	P2002	17	Out

### 5.2.7 VOR/ILS Discrete Inputs

This input is considered active if either the voltage to ground is  $\leq 3.5$  VDC or the resistance to ground is  $\leq 375$   $\Omega$ . This input is considered inactive if the voltage to ground is 11-33 VDC or the resistance to ground is  $> 100$  k $\Omega$ .

Pin Name	Connector	Pin	I/O
VLOC REMOTE TRANSFER*	P2002	28	In

An asterisk (\*) following a signal name denotes that the signal is an Active-Low, requiring a ground to activate.

#### 5.2.7.1 VOR/LOC REMOTE TRANSFER\*

VOR/LOC REMOTE TRANSFER\* discrete input may be used to flip-flop between the active and standby NAV frequencies. A momentary low on this pin will load the standby NAV frequency into the active NAV frequency field.

## 5.2.8 VOR/ILS Indicator

VOR/ILS indicator displays both lateral and vertical, To/From indications, lateral and vertical flags, and superflags. Connector P1002 always outputs the VOR/Localizer/Glideslope navigation information. The VOR/ILS pins on P1002 are used to drive an indicator that displays VOR/ILS information at all times, regardless of the CDI selection on the GTR/GNC.

VOR/LOC COMPOSITE OUT is a standard VOR/localizer composite output signal which may be used to drive Left/Right, To/From, and Flag indications of certain navigation indicators that contain an internal converter.

ILS ENERGIZE output becomes active (low) when VOR/LOC frequency is set to a localizer channel.

### 5.2.8.1 VOR/ILS Indicator Electrical Characteristics

#### 5.2.8.1.1 Superflags

The output supplies not less than 320 mA with the output voltage not less than (AIRCRAFT POWER -2 VDC) when the flag is to be OUT OF VIEW. The output voltage with respect to ground is 0 +/-250 mVDC when the flag is to be IN VIEW.

Pin Name	Connector	Pin	I/O
VOR/LOC SUPERFLAG*	P2002	15	Out
GLIDESLOPE SUPERFLAG*	P2002	38	Out

#### 5.2.8.1.2 Deviation

Deviation outputs are each capable of driving up to three 1000  $\Omega$  loads with  $\pm 150$  mVDC  $\pm 15$  mVDC for full-scale deflection, 0 mVDC  $\pm 4.5$  mVDC when centered. The drive circuit provides for more than full-scale deflection with a maximum course deviation output voltage of  $\pm 300$  mVDC  $\pm 30$  mVDC.

Pin Name	Connector	Pin	I/O
VOR/LOC +LEFT	P2002	5	Out
VOR/LOC +RIGHT	P2002	6	Out
GLIDESLOPE +UP	P2002	34	Out
GLIDESLOPE +DOWN	P2002	55	Out

#### 5.2.8.1.3 TO/FROM

TO/FROM output is capable of driving up to three 200  $\Omega$  loads. When indicating TO, the output is  $+225 \pm 75$  mVDC. When indicating FROM, output is  $-225 \pm 75$  mVDC. When invalid information is present (Flag IN VIEW) the TO/FROM output is  $0 \pm 10$  mVDC.

Pin Name	Connector	Pin	I/O
VOR/LOC +TO	P2002	1	Out
VOR/LOC +FROM	P2002	2	Out

#### 5.2.8.1.4 Flag

Pin Name	Connector	Pin	I/O
VOR/LOC +FLAG	P2002	3	Out
VOR/LOC -FLAG	P2002	4	Out
GLIDESLOPE +FLAG	P2002	32	Out
GLIDESLOPE -FLAG	P2002	53	Out

#### 5.2.8.1.5 OBS

VOR OBS ROTOR C and H are a buffered 400 Hz output that is intended to drive the OBS rotors. VOR OBS STATOR D and VOR OBS STATOR F are each amplitude shifted versions of the VOR ROTOR C output. Each pair is intended to read one of the two windings of the indicator's OBS stator.

Pin Name	Connector	Pin	I/O
VOR OBS ROTOR C	P2002	9	Out
VOR OBS ROTOR H (GND)	P2002	10	--
VOR OBS STATOR D	P2002	13	In
VOR OSB STATOR E (GND)	P2002	11	--
VOR OBS STATOR F	P2002	12	In
VOR OBS STATOR G (GND)	P2002	14	--

#### 5.2.8.1.6 VOR/LOC COMPOSITE

With a standard VOR test signal applied, VOR/LOC COMPOSITE OUT is  $0.5 \pm 0.1$  V<sub>rms</sub> into a 10 k $\Omega$  load. With a standard Localizer centering test signal applied, VOR/LOC COMPOSITE OUT is  $0.350 \pm 0.05$  V<sub>rms</sub> into a 10 k $\Omega$  load.

Pin Name	Connector	Pin	I/O
VOR/LOC COMPOSITE OUT	P2002	8	Out

#### 5.2.8.1.7 GLIDESLOPE COMPOSITE

With a standard glideslope test signal applied, GLIDESLOPE COMPOSITE OUT is  $0.350 \pm 0.05$  V<sub>rms</sub> into a 10 k $\Omega$  load.

Pin Name	Connector	Pin	I/O
GLIDESLOPE COMPOSITE OUT	P2002	58	Out

#### 5.2.8.1.8 NAV ILS ENERGIZE

The driver output voltage is not more than 1.0 V when sinking 20 mA. The maximum off state leakage current with respect to GND is less than 10  $\mu$ A.

Pin Name	Connector	Pin	I/O
ILS ENERGIZE	P2002	29	Out

## 5.2.9 RMI/OBI

### 5.2.9.1 RMI/OBI Function

VOR OBI output provides bearing information from the currently tuned VOR station for Bendix/King Serial OBI devices based upon the VOR receiver. When a localizer channel is tuned on the VOR/LOC window, there is a bit in the data stream set to indicate that a localizer frequency is tuned which stows the needle or drives it to the three o'clock position.

### 5.2.9.2 RMI/OBI Electrical Characteristics

The output driver is an Active-Low. The driver output voltage is not more than 1.0 V when sinking 20 mA. The maximum off state leakage current with respect to ground is less than 10  $\mu$ A.

Pin Name	Connector	Pin	I/O
VOR OBI CLOCK	P2002	25	In
VOR OBI SYNC	P2002	26	In
VOR OBI DATA	P2002	27	In

## 5.2.10 DME Tuning

### 5.2.10.1 DME Tuning Function

The GTR/GNC can channel a DME based on the tuned VOR/LOC frequency. The GTR/GNC 2 of 5, BCD, or Slip parallel DME and King Serial DME channeling format. When DME COMMON is held low, the GTR/GNC actively tunes the DME.

### 5.2.10.2 DME Tuning Electrical Characteristics

#### 5.2.10.2.1 Parallel DME Tuning

For each of the parallel DME tuning discrete outputs, the driver output voltage is not more than 1.0 V while sinking 20 mA. The maximum off state leakage current with respect to ground is less than 10  $\mu$ A.

DME COMMON must be pulled low to indicate to the GTR/GNC that it is the device channeling the DME.

DME COMMON is considered active if either the voltage to ground is less than 1.9 V or the resistance to ground is less than 375  $\Omega$ . These inputs are considered inactive if the voltage to ground is 11-33 VDC.

Pins 37, 40, 41, 42, 43, 45, 47, 33, 54, and 56 are configured for 2 of 5 parallel DME tuning.

Pin Name	Connector	Pin	I/O
PAR DME 100kHz-A/SERIAL DME ON	P2002	37	Out
PAR DME 100kHz-B	P2002	39	Out
PAR DME 100kHz-C	P2002	40	Out
PAR DME 100kHz-D	P2002	42	Out
PAR DME 100kHz-E	P2002	54	Out
PAR DME 50kHz	P2002	43	Out
PAR DME 1MHZ-A	P2002	45	Out
PAR DME 1MHZ-B	P2002	46	Out
PAR DME 1MHZ-C	P2002	47	Out
PAR DME 1MHZ-D/SERIAL DME ON	P2002	33	Out
PAR DME 1MHZ-E	P2002	56	Out
DME COMMON	P2002	41	In



### 5.2.10.2.2 King Serial DME Tuning

When SERIAL DME – DATA or SERIAL DME – CLOCK is asserted high and driving a 360  $\Omega$  load, the driver output voltage is not less than 8 V, and when asserted low is not greater than 10 mV.

SERIAL DME – RNAV/CH REQ, SER DME – RNAV MODE, and DME COMMON are considered active if either the voltage to ground is less than 1.9 V or the resistance to ground is less than 375  $\Omega$ . These inputs are considered inactive if the voltage to ground is 11-33 VDC.

DME COMMON must be pulled low to indicate to the GTR/GNC that it is the device channeling the DME.

Pins 18, 19, 20, and 41 are configured for King Serial DME tuning.

Pin Name	Connector	Pin	I/O
SERIAL DME - DATA	P2002	19	I/O
SERIAL DME - CLOCK	P2002	18	I/O
SERIAL DME - RNAV/CH REQ	P2002	20	In
SERIAL DME - RNAV MODE	P2002	21	In
DME COMMON	P2002	41	In
SERIAL DME - DME REQUEST	P2002	44	I/O

## 6 POST INSTALLATION CONFIGURATION AND CHECKOUT PROCEDURES

### 6.1 System Configuration Overview

Checkout and configuration instructions for the GTR/GNC is provided in this section.

- Configure the GTR/GNC for the specific installation (section 6.4)
- Perform the installation checks (section 6.5)
- Perform ground checks to verify the interfaces to external sensors (section 6.6)
- Perform the specified flight checks (section 6.7)

### 6.2 Mounting, Wiring, and Power Checks



#### CAUTION

*Connection of the power or lighting bus to incorrect pins can cause damage to the unit, which will require return to the factory for repair. Always start tests with the dimming bus at the lowest setting, and slowly increase the brightness. Verify the wiring is correct if it is noticed the lighting level on the GTR/GNC does not increase as the lighting bus input is increased in brightness.*

Verify that all cables are properly secured and shields are connected to the shield block of the connectors. Check the movement of the flight and engine controls to verify there is no interference between the cabling and control systems. Ensure that all wiring is installed as described in section 3.4.

Prior to powering up the GTR/GNC, the wiring harness must be checked for proper connections to the aircraft systems and other avionics equipment. Point to point continuity must be checked to expose any faults such as shorting to ground. Any faults or discrepancies must be corrected before proceeding.

After accomplishing a continuity check, perform power and ground checks to verify proper power distribution to the GTR/GNC. Any faults or discrepancies should be corrected at this time. Remove power from the aircraft upon completion of the harness checkout.

The GTR/GNC can be installed after completion of the continuity and power checks. The GTR/GNC should be installed into the rack and secured appropriately, as described in section 4.7.1. The GTR/GNC must be connected to the wiring harness and antennas.

### 6.3 Connector Engagement Check

Check the connector engagement prior to configuration and checkout of the GTR/GNC.

1. Turn on the avionics master switch (if installed).
2. Place the GTR/GNC in the rack and engage the cam mechanism.
3. Turn the Allen screw of the locking cam (located on the lower left side of the unit) slowly clockwise until the GTR/GNC just powers on. A T-handle can be used for this, but ensure that the screw is not over-tightened.
4. Count the number of complete revolutions the Allen screw can be turned until it cannot turn any more. Do not over-tighten. Three turns is the minimum for proper installation. If fewer than three turns are possible, the mounting rack should be moved aft (toward the pilot) such that the aircraft panel does not obstruct the unit from properly engaging in the rack.

### 6.4 Configuration Mode Operations

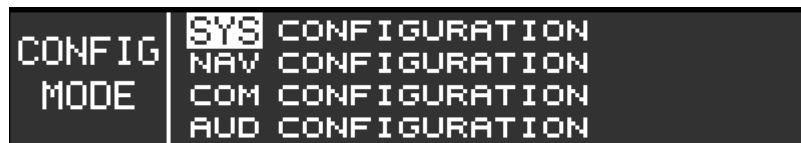
The configuration pages shown in this section reflect main software version 2.00. Some differences in operation may be observed when comparing the information in this manual to later software versions.

Configuration mode is used to configure the GTR/GNC settings for each specific installation.

To access configuration mode:

1. Remove power from the GTR/GNC.
2. Press and hold the **ENT** key.
3. Apply power to the GTR/GNC by turning the COM volume knob.
4. When “Garmin” appears on the screen release the **ENT** key.

The first page displayed is the CONFIG MODE page. In configuration mode there are five configuration groups. The five groups, SYS, NAV, COM, AUD, and LOG each have pages. The outer knob is used to access the groups. The inner knob is used to access the pages of the groups. The **ENT** key is used to confirm the selection of page.



**Figure 6-1 Configuration Mode Page**

## 6.4.1 SYS Configuration Group

### 6.4.1.1 Serial Port Page

The SERIAL PORT page configures the input/output (I/O) mode for the RS-232 port. See table 6-1 for the selections available.

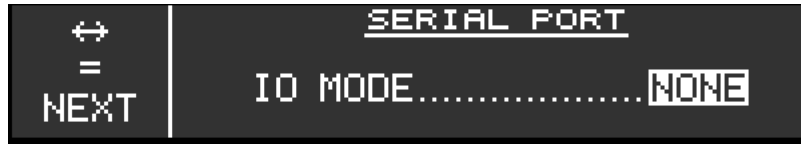


Figure 6-2 Serial Port Page

Table 6-1 Serial Port Selections

Selection	Description
NONE (DEFAULT)	No serial data input/output.
AVN IN/MAPCOM	Serial port will receive “RS-232 Aviation” format input data, as defined in appendix B.1 (for example, as received from Garmin GTN 6XX/7XX and GNS 400W/500W Series navigators). There is no serial data output from the GTR/GNC with this selection.
NMEA	Serial data “RS-232 NMEA” input/output as defined in appendix B.2 (for example, with G500/G600, GPSTMap, Aera Series, XL Series, or GX Series). <b>See WARNING.</b>



#### WARNING

*Do not use the NMEA serial port selection with GNC 255 display software version 2.01 when connected to an external device, which uses CDI deviation data from the GNC’s RS-232 NMEA data output. Using this NMEA serial port selection with display software version 2.01 may result in VOR reversed course deviation indication.*



#### NOTE

*The G500/G600 does not utilize CDI deviation data from the GNC 255’s RS-232 NMEA data output.*

### 6.4.1.2 DST Priority Page

If both GPS and DME systems are providing data to the GNC, the DST PRIORITY page configures the source priority for the display of distance, speed, time (DST) information. The GNC displays DST data from a DME or a GPS device. Select “GPS, DME” to give priority to DST data from a connected GPS receiver or “DME, GPS” to give priority to DST data from a connected DME receiver.



Figure 6-3 DST Priority Page

### 6.4.1.3 Intercom Enable Page

Intercom mode is enabled or disabled on the INTERCOM ENABLE page. See table 6-2 for available selections.



Figure 6-4 Intercom Enable Page

Table 6-2 Intercom Enable Page Selections

Selection	Description
DISPLAY	Allows the intercom to be enabled or disabled via a menu option on the GTR/GNC display. After selecting DISPLAY, the intercom enable/disable setting will appear in normal mode.
DISCRETE	Selecting DISCRETE allows the intercom to be enabled or disabled via a remote switch connected to the INTERCOM ENABLE* discrete input (P2001-12). This selection will remove the menu option to enable/disable the intercom.

### 6.4.1.4 Backlight Page

The BACKLIGHT page selects the source for the display and bezel key lighting. Minimum brightness levels of the display and key are also configured on the BACKLIGHT page.



Figure 6-5 Backlight Page

The display source is configured to track either photocell or lighting bus 1. The bezel key source is configured to track the photocell, lighting bus 1, or lighting bus 2. See table 6-3 for description of selections on the BACKLIGHT page.

Table 6-3 Backlight Selections

Selection	Description
PHOTOCELL	Backlight or bezel key lighting level is determined by the ambient light level as measured by the photocell on the GTR/GNC.
LIGHT BUS 1	Backlight or bezel key levels track the lighting bus 1 levels.
LIGHT BUS 2	Bezel key lighting levels track the lighting bus 2 levels.

The minimum brightness level of the display and bezel keys is configurable on the BACKLIGHT page. This sets the minimum brightness of the bezel keys or display. The display minimum brightness level has a range from 1 to 100. The default level is 1. The bezel key minimum brightness level has a range from 0 to 100. The default level is 1.

### 6.4.1.5 Photocell Page

The PHOTOCCELL page configures the parameters of the photocell. See table 6-4 for description of each parameter.

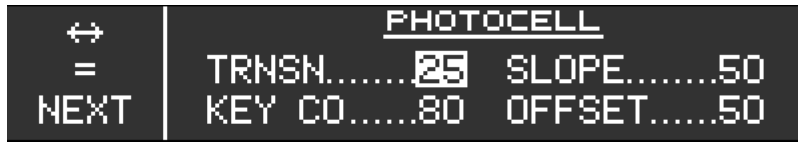


Figure 6-6 Photocell Page

Table 6-4 Photocell Page Parameter Description

Selection	Description
TRNSN (Transition)	When a lighting bus is used to control the lighting of the display, this parameter sets the point on the lighting bus control below, which the display brightness tracks the GTR/GNC photocell. This field has a range of 5 to 50, and is set to 25 as the default setting.
SLOPE	Sets the sensitivity the brightness of the display or keys has to changes in the photocell input level. Adjusting the slope higher will result in a brighter display for a given increase in the photocell input level. This field has a range of 0 to 100, and is set to 50 as the default setting.
KEY CO (Key Cutoff)	This parameter configures the point when key backlighting is switched off in bright light. For example, a value of 70 results in the key backlights being turned off at photocell source input levels above 70%. This field has a range of 0 (zero) to 100 and is set to 80 as the default setting.
OFFSET	Adjusts the lighting level up or down for any given photocell input level. This field has a range of 0 (zero) to 100, and is set to 50 as a default value. This may also be used to match lighting curves with other equipment in the panel.

### 6.4.1.6 Lighting Bus 1 and Lighting Bus 2

The LIGHTING BUS 1 and LIGHTING BUS 2 page configures the parameters of each lighting bus. See table 6-5 for descriptions of each parameter.



Figure 6-7 Lighting Bus Page

Table 6-5 Lighting Bus Parameter Description

Selection	Description
INPUT	This setting configures the lighting bus source voltage. Select 14 VDC, 28 VDC, 5 VDC, or 5 VAC, depending on the lighting bus voltage source.
SLOPE	This setting determines how sensitive the display or bezel keys are to changes in the lighting bus input level. Adjusting the slope higher will result in a brighter display for a given increase in the lighting bus input level. This field has a range of 0 to 100, and is set to 50 as the default setting.
OFFSET	This setting adjusts the lighting level up or down for any given lighting bus input level. This field has a range of 0 (zero) to 100, and is set to 50 as a default value. This may also be used to match lighting curves with other equipment in the panel.

### 6.4.1.7 Display Information Page

The DISPLAY INFORMATION page shows the display software version, software part number, unit serial number, minimum software level, hardware version, boot version, part number, and minimum boot version of the unit.



Figure 6-8 Display Information Pages

### 6.4.1.8 Display Update Page

The DISPLAY UPDATE page loads the display software to the GTR/GNC. See section 6.8 for instructions on how to load software to the GTR/GNC.



Figure 6-9 Software Update Page

## 6.4.2 NAV Configuration Group (GNC Only)

### 6.4.2.1 CDI Indicator Page

The CDI INDICATOR page configures the type of Course Deviation Indicator (CDI) that is connected to the GNC. The setting is based upon the connected CDI. See table 6-6 for settings.

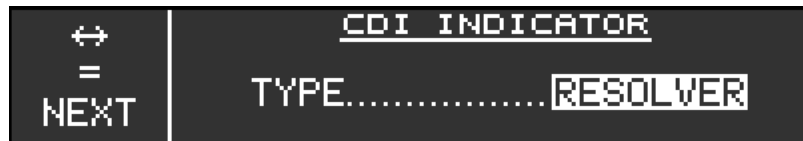


Figure 6-10 CDI Indicator Page

Table 6-6 CDI Indicator Selections

Selection	Description
NONE (DEFAULT)	No external resolver is supported. OBS mode allows the user to edit the OBS with concentric knobs. Serial OBS update messages are supported in this mode, but the unit will not flag if updates are discontinued or are not periodic.
RESOLVER	Auto-decodes resolver setting via six-wire resolver interface. Uses internal DSP to compute course information. See section 6.5.1 for calibration.
CONVERTER	Disables all internal OBS functions. Allows use of conventional external converter via the composite output pin.
SERIAL	For use with serial Electronic Flight Instrument System (EFIS) conforming to the Garmin serial data specification. See appendix B.



### 6.4.2.2 Calibrate OBS Resolver Page (GNC Only)

The CALIBRATE OBS RESOLVER page calibrates the OBS resolver. See section 6.5.1 for instructions on how to calibrate the OBS resolver.



Figure 6-11 Calibrate OBS Resolver Page

### 6.4.2.3 ARINC 429 Page (GNC Only)

The ARINC 429 page configures the NAV ARINC 429 output on the GNC. Configure the port according to the connected VOR/ILS indicator. See table 6-7 and table 6-8 for description of the configuration speeds.



Figure 6-12 ARINC 429 Page

Table 6-7 ARINC 429 Configuration Speed (TX)

Selection	Description
LO SPEED	Standard low-speed ARINC 429 (nominally 12.5 kilobits per second)
HI SPEED	High-speed ARINC 429 (nominally 100 kilobits per second)

Table 6-8 SDI Selections

Selection	Description
COMMON	Generates all 429 outputs with SDI = 0
VOR/ILS 1	Number 1 (Pilot) VOR/ILS Receiver TX: Generates all 429 outputs with SDI = 1
VOR/ILS 2	Number 2 (Copilot) VOR/ILS Receiver TX: Generates all 429 outputs with SDI = 2

The following labels are output on the VOR/ILS ARINC 429 OUT Port.

Label #	Parameter Name
034G	VOR/ILS Frequency (BCD)
035G	DME Frequency (BCD)
100G	Selected Course #1
173	Localizer Deviation
174	Glideslope Deviation
222	VOR Omnibearing
371G	Specific Equipment ID
377	Equipment Hex ID Code

#### 6.4.2.4 DME Configuration (GNC Only)

Select the DME CONFIGURATION page to configure the DME channel mode settings.

##### 6.4.2.4.1 Mode (DME Channel Mode)

This configuration setting sets the format for DME tuning data output. See table 6-9 for DME settings.

**Table 6-9 DME Settings**

Selection	Description
KING SERIAL	King serial DME tuning data
PARALLEL 2X5	2 of 5 parallel DME tuning
PARALLEL BCD	Shifted Binary Coded Decimal (BCD) parallel DME tuning
PARALLEL SLIP	Slip-code parallel DME tuning
NARCO 890/891	2 of 5 parallel DME tuning, compatible with the following Narco DME units: <i>DME 890</i> <i>DME 891</i>

##### 6.4.2.4.2 A429

**Table 6-10 A429 Settings**

Selection	Description
DIRECTED FREQ 1	If the GNC is connected to a multi-channel ARINC 429 DME, channel 1 of that DME is tuned. DIRECT FREQ 1 should be selected if a single-channel ARINC 429 DME is to be tuned.
DIRECTED FREQ 2	If the GNC is connected to a multi-channel ARINC 429 DME, channel 2 of that DME is tuned.

### 6.4.2.5 NAV Info Page

The NAV INFORMATION page shows the NAV board software version, software part number, and hardware version.



Figure 6-13 NAV Information Page

### 6.4.2.6 NAV Update

The NAV update page loads the NAV software to the GNC. See section 6.8 for instructions on loading software to the GNC.



Figure 6-14 NAV Software Update Page

### 6.4.3 COM Configuration Group

#### 6.4.3.1 MIC Gain Page

The MIC GAIN page sets the MIC gains for MIC 1 and MIC 2. The MIC 1 and MIC 2 gain is adjustable from -12 dB to +30 dB in 6 dB increments. The default is +12 dB. For MICs with low signal levels, this can be adjusted up to increase the signal strength. For MICs with high signal levels, this can be adjusted down to decrease the signal strength. The MIC 2 gain setting is dependent upon the MIC 1 gain setting.

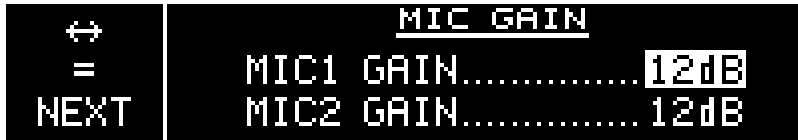


Figure 6-15 MIC Gain Page



**NOTE**

For COM software version 2.12 or earlier, the MIC1 and MIC2 gain settings are transposed. Change MIC1 gain setting to adjust the actual MIC2 gain. Change MIC2 gain setting to adjust the actual MIC1 gain.

#### 6.4.3.2 COM RX Squelch Page

The COM RX SQUELCH page configures the squelch for the COM receiver. The COM RX squelch adjusts the signal strength required to break squelch for the COM receiver. See table 6-11 for a description of each setting.

Garmin changed the GTR/GNC COM radio factory calibration process to allow the level when the auto squelch opens or closes, to be set at a more sensitive level. The COM RX squelch range (0-100) was remapped as shown in table 6-11. Installations of radios with the expanded sensitivity calibration process may require a different COM RX squelch setting to achieve the desired RX squelch performance. Current production units are shipped with the expanded sensitivity calibration process.

Table 6-11 contains the approximate levels when the auto squelch opens and closes for various COM RX squelch settings. Installations of GTR/GNCs with the expanded sensitivity calibration will generally use a COM RX squelch setting of 75 or higher. Installations of GTR/GNCs with the original sensitivity calibration will generally use a COM RX squelch setting of zero or higher.



Figure 6-16 COM RX Squelch Page

**Table 6-11 COM RX Squelch Selections**

Selection	Description
BASIC	The COM RX SQUELCH value is applied to all frequencies.
ADVANCED [1]	The COM RX SQUELCH values can be set for low, mid, and high frequencies. The COM RX SQUELCH value is linearly interpolated for frequencies between the low (118.000 MHz), mid (127.000 MHz), and high (136.975 MHz or 136.990 MHz for 25kHz and 8.33 kHz spacing, respectively) frequency values.
SPACING	The COM RX squelch values are adjusted separately for 25 kHz and 8.33 kHz spacing.
SQUELCH (BASIC) LOW, MID, HIGH (ADVANCED)	The COM RX squelch is adjustable in the range of 0 to 100. The default value is zero. Decreasing the value will allow the squelch to be broken with low signal levels. Increasing the value will require higher signal levels to break squelch.

[1] Software version 2.10 or later.

**Table 6-12 COM RX Squelch Settings**

COM RX Squelch Setting [1]		Original Calibration Approximation	Expanded Calibration Approximation
0 [2]	Auto Squelch Open	-99 dBm	-105 dBm
	Auto Squelch Close	-101 dBm	-107 dBm
75 [2]	Auto Squelch Open	-97 dBm	-99 dBm
	Auto Squelch Close	-99 dBm	-101 dBm
100	Auto Squelch Open	-93 dBm	-93 dBm
	Auto Squelch Close	-95 dBm	-95 dBm

[1] The COM RX squelch range (0-100) is a non-linear response.

[2] Many typical installations have the auto squelch set to close at approximately -101 dBm.

### 6.4.3.3 COM Information Page

The COM INFORMATION page shows the COM board software version, software part number, hardware version, boot version, boot P/N, FPGA version, and FPGA P/N.



**Figure 6-17 COM Information Page**

### 6.4.3.4 COM Update Page

The COM UPDATE page loads the COM software to the GTR/GNC. See section 6.8 for instructions on loading COM software to the GTR/GNC.



Figure 6-18 COM Software Update Page

## 6.4.4 Audio Configuration Group

### 6.4.4.1 COM Sidetone Page

COM sidetone is the audio spoken into the COM microphone. The COM SIDETONE page adjusts the volume, mode and pilot control of the COM sidetone. This setting only affects the volume of the sidetone for the GTR/GNC COM during PTT. To adjust the COM sidetone volume, turn the inner knob to the desired value. This field is adjustable in the range of 0 to 100. The default is 50. See table 6-13 and table 6-14 for descriptions of each selection.



**NOTE**

*The COM sidetone volume set in configuration mode is the value used when the FIXED COM sidetone mode is selected in normal mode.*



Figure 6-19 COM Sidetone Page

Table 6-13 COM Sidetone Mode Selections  
(Software Version 2.10 or Later)

Selection	Description
EXTERNAL (DEFAULT)	The COM sidetone audio that the pilot hears is the demodulated audio signal that is actually going to the antenna to be transmitted.
INTERNAL	The COM sidetone audio that the pilot hears is the audio signal from the headset microphone before it is filtered for transmission.



**NOTE**

*When INTERNAL is selected, the audio signal has higher dynamic range and has a more full sound. However, transmitted audio quality issues may not be noticed by the pilot until notified by air traffic control (ATC). Some pilots prefer the sound quality of the internal sidetone versus the external sidetone.*

**Table 6-14 COM Sidetone Pilot Control  
(Software Version 2.10 or Later)**

Selection	Description
DISABLE	The COM sidetone volume is set in configuration mode.
ENABLE	Allows the pilot to select the COM sidetone volume to change with adjustments of the COM RX volume.

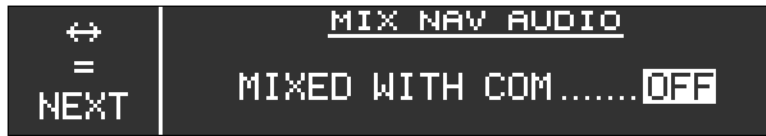


**NOTE**

*The COM sidetone volume set in configuration mode is the value used when the FIXED COM sidetone mode is selected in normal mode.*

**6.4.4.2 Mix NAV Audio Page**

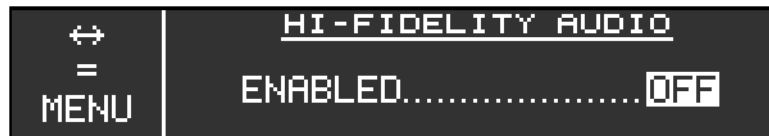
The MIX NAV AUDIO page configures whether NAV audio is mixed with the COM headphones. With this option set to ON, the NAV audio will be sent along with COM audio to the pilot’s headphones and the audio will be combined. With this option set to OFF, the NAV audio will not be heard in the pilot’s headphones. The NAV audio will still be sent over the analog audio lines on P2002-16 and 17. In installations with an audio panel, this should be set to OFF. Turn the inner knob to ON or OFF. Press **ENT** when the selection is displayed.



**Figure 6-20 Mix NAV Audio Page**

**6.4.4.3 Hi-Fidelity Audio Page**

The HI-FIDELITY AUDIO page enables or disables the hi-fidelity AUX audio input on the GTR/GNC. If a music audio source is connected to P2001-3 and 19, it may be desirable to enable the hi-fidelity audio. Turn the inner knob to ON or OFF. Press **ENT** when the appropriate selection is displayed.



**Figure 6-21 Hi-Fidelity Audio Page**

## 6.4.5 Log Functions Group

### 6.4.5.1 Download Log Page



#### NOTE

*Garmin recommends the use of a USB 2.0 compatible flash drive for downloading files from the GTR/GNC. The flash drive must be formatted as FAT32.*

The DOWNLOAD LOG page is where the GTR/GNC keeps an error log to aid in diagnostics and troubleshooting. The error log can be downloaded to a flash drive attached to the USB port on the GTR/GNC.

To download the error log:

1. Insert the supplied USB cable into the USB port of the GTR/GNC.
2. Attach a USB flash drive to the other end of cable.
3. Turn outer knob to LOG FUNCTIONS.
4. Turn inner knob to DOWNLOAD LOG.
5. Press **ENT**.
6. Press **ENT** again to begin download.



Figure 6-22 Download Log Page

### 6.4.5.2 Clear Error Log Page

The CLEAR ERROR LOG page clears the internal error log on the GTR/GNC.

To clear all stored the error logs:

1. Turn outer knob to LOG FUNCTIONS.
2. Press **ENT**.
3. Turn inner knob to CLEAR ERROR LOG.
4. Press **ENT**.
5. Press **ENT** again to clear error log.

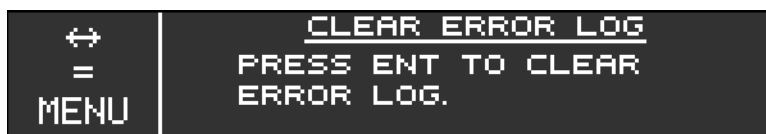


Figure 6-23 Clear Error Logs Page



## 6.5 Ground Checks (Configuration Mode)

The following checks are performed in configuration mode, see section 6.4.

### 6.5.1 Calibrate Resolver (GNC Only)

It is necessary to calibrate the interface between the GNC and the resolver after selecting RESOLVER as the CDI indicator head type on the CDI INDICATOR page, figure 6-10. The accuracy of the system is dependent on this calibration. The GNC cannot drive multiple resolvers at the same time. It is not recommended that external resolvers be switched through a relay or other means because the resolver must be calibrated to the radio. If multiple resolvers are desired in the installation, the primary unit must be installed and calibrated as described here. The secondary unit should use the composite output.

To calibrate:

1. Turn outer knob to NAV CONFIGURATION.
2. Turn inner knob to CAL RESOLVER.
3. Press **ENT**.
4. Follow the directions on the GNC display.



**Figure 6-24 Calibrate OBS Resolver Page**

5. At the end of setup, press **ENT** to store results.
6. Tune to any VOR frequency.
7. Press **OBS**.
8. Verify that the OBS decoded properly from 0 to 360 degrees.

If the GNC will not accept the calibration, there may be a problem with the resolver interface. Verify wiring and contact Garmin for assistance, if necessary.

### 6.5.2 Test Analog Flags (GNC Only)

The TEST ANALOG FLAGS sends an active signal for testing the interface with connected devices. The test includes NAV (NAV), GS (Glideslope), and T/F (To/From). The TEST ANALOG FLAGS page can be found in the NAV group (figure 6-1).



**NOTE**

*Some CDIs/HSIs require that the ILS ENERGIZE discrete be active for flags check and CDI/VDI check to function properly.*

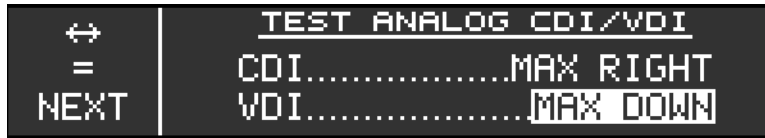


**Figure 6-25 Test Analog Flags Page**

1. Select the TEST ANALOG FLAGS page.
2. Press **ENT**.
3. Turn the inner knob to set the NAV flag as VALID or INVALID.
4. Verify the applicable flag is displayed on connected indicator.
5. Turn the outer knob to GS.
6. Turn the inner knob to set the GS flag as VALID or INVALID.
7. Verify the applicable flag is displayed on connected indicator.
8. Turn the outer knob to T/F.
9. Turn the inner knob to set the T/F flag as FROM, TO, or HIDDEN.
10. Verify the flags on the connected indicator function as configured.

### 6.5.3 Test Analog CDI/VDI (GNC Only)

The TEST ANALOG CDI/VDI page allows the analog indicator connected to the GNC to be verified for proper wiring and operation.



**Figure 6-26 Test CDI/VDI Page**

Perform the following steps if the GNC is interfaced to an analog indicator.

1. Select the TEST ANALOG CDI/VDI page.
2. Press **ENT**.
3. Turn the outer knob to select between CDI and VDI.
4. On the CDI selection, verify correct operation of the lateral deviations on the indicator by using the corresponding selections (MAX LEFT, FULL LEFT, CENTERED, FULL RIGHT, MAX RIGHT).
5. On the VDI selection, verify correct operation of the vertical deviations on the indicator by using the corresponding selections (MAX UP, FULL UP, CENTERED, FULL DOWN, MAX DOWN).

### 6.5.4 Lighting Bus Interface Check



#### **CAUTION**

*When 14 VDC or 28 VDC lighting buses are connected to the GTR/GNC, connection of the aircraft lighting bus to the incorrect input pins can cause damage to the GTR/GNC. Always start this test with the dimming bus at the lowest setting, and slowly increase the brightness. If the brightness level on the GTR/GNC display does not increase as the lighting is increased in brightness, verify that the wiring is correct before proceeding.*

The display and bezel key backlighting on the GTR/GNC tracks an external lighting/dimmer bus input and uses it to vary the display and bezel key backlight levels accordingly. This check verifies the interface.

1. Ensure the lighting bus is set to its minimum setting.
2. Slowly vary the lighting bus level that is connected to the GTR/GNC.
3. Verify the display brightness tracks the lighting bus setting.
4. Continue to maximum brightness and verify operation.

## 6.6 Ground Checks (Normal Mode)

### 6.6.1 Discrete Input Checkout

**Table 6-15 Discrete Input Pins**

Pin	Pin Name	Description
P2001-12	INTERCOM ENABLE*	Enables the intercom function on the GTR/GNC.
P2001-27	COM REMOTE TRANSFER*	Flip-flops the active and standby COM frequencies.
P2001-28	COM REMOTE TUNE UP*	Scrolls up through the preset COM frequencies in the standby frequency field.
P2001-29	COM REMOTE TUNE DOWN*	Scrolls down through the preset COM frequencies in the standby frequency field.
P2002-28	VLOCK REMOTE TRANSFER	Flip-flops the active and standby NAV frequencies.

If a switch is connected to any pins listed in table 6-15, perform the following procedure:

1. Exercise the switch source for each of the switches that are connected.
2. Verify that the function controlled by the switch operates as intended.
3. Verify the wiring between the GTR/GNC and the switch if not operating as intended.

### 6.6.2 VHF NAV Checkout

Check the VOR reception with ground equipment, operating VOT or VOR, and verify audio and Morse code ID functions, if possible. Tune a localizer frequency and verify the CDI needle, NAV flag, VDI needle and GS flag operation.

### 6.6.3 NAV Audio Check (Audio Panel Installations) (GNC Only)

Ensure the audio panel is powered on and perform the following steps:

1. Plug in a headset at pilot and copilot position.
2. Tune the GNC NAV receiver to a local VOR station
3. Select NAV audio on the audio panel.
4. Ensure the Morse code identifier is being received over the crew headsets.
5. Verify the wiring connections to the audio panel, if the audio is not heard.,
6. Ensure the audio volume is sufficient for all anticipated cockpit noise conditions.

## 6.6.4 VHF COM

### 6.6.4.1 Antenna Check

If desired, the antenna VSWR can be checked using an inline wattmeter in the antenna coaxial using frequencies near both ends of the band. The VSWR should be less than 2:1. A VSWR of 2:1 will cause a drop in output power of approximately 12%.

### 6.6.4.2 Receiver/Transmitter Check

1. Tune the unit to a local VHF frequency
2. Verify the receiver output produces a clear and understandable audio output.
3. Verify the transmitter functions properly by contacting another station and getting a report of reliable communications.

### 6.6.4.3 Aux Audio Input Check

This check is only required for installations with an AUX audio source connected to pin P2001-3 and pin P2001-19.

1. Connect an audio source to the AUX Audio input (P2001-3 and P2001-19).
2. Verify that AUX audio is heard over the pilot headset position.

### 6.6.4.4 Database Check

Check the frequency database to ensure it is current. The database information is displayed during the unit display start-up sequence. To check the database:

1. Cycle power on the GTR/GNC and let the start-up sequence complete.
2. Press **FUNC**.
3. Turn the outer knob to SYS CONFIGURATION.
4. Turn the inner knob to DATABASE INFO.
5. Press **ENT**.
6. Verify the frequency database effectivity (EFCTV) date has not lapsed.

### 6.6.4.5 RS-232 Serial Interface Checks

The interfaces to RS-232 equipment such as the GTN 6XX/7XX or GNS 400W/500W series GPS sources should be checked as follows.

1. Operate the connected GPS source and the GTR/GNC in normal mode.
2. Ensure the aircraft has a clear view of the sky for this check. This check should not be performed in a hangar.
3. Verify the connected GPS source has a valid GPS satellite fix.
4. Press **FUNC**.
5. Turn the inner knob to NEAREST APT.
6. Press **ENT**.
7. Verify the wiring between the GPS source and the GTR/GNC if the GTR/GNC displays “NO GPS.”

The interfaces to RS-232 equipment such as the G500/G600 or other serial interface should be checked as follows.

1. Operate the connected serial remote tune source and the GTR/GNC in normal mode.
2. Ensure the remote source is able to display data from the GTR/GNC.

## **6.6.5 Interface Checkout**

This section describes the checks that must be carried out to verify that systems interfacing to the GTR/GNC are communicating properly. Only those interfaces that are connected to the GTR/GNC must be verified.

### **6.6.5.1 External RMI/OBI Interface Check (GNC Only)**

Verify the interface if the VOR OBI output from the GNC is connected to an RMI navigation indicator. Check the electrical connections and configuration setup if the following steps do not perform correctly. The aircraft heading system must be operating properly in order for the RMI needle to point correctly.

1. Apply power to the equipment.
2. If installed, set the RMI select switch to the VLOC position.
3. Tune a local VOR station, or use a simulated signal from an approved VOR test system.
4. Verify the RMI needle swings and points toward the VOR station.

### **6.6.5.2 DME Tuning Check (GNC Only)**

Verify the interface if the GNC is set up to remotely channel a DME as follows.

1. Select a VOR/ILS channel that corresponds to one of the following.
  - a. A DME station within a 40 nautical mile range
  - b. The frequency of a DME ground tester.
2. Verify that the DME locks on to the signal and a valid distance is displayed.
3. Tune an invalid VOR station.
4. Verify the DME data is flagged.

## 6.7 Flight Checks

After the installation is complete, a flight check is recommended to ensure satisfactory performance.

### 6.7.1 COM Flight Check

To check the communications transceiver, maintain an appropriate altitude and contact a ground station facility at a range of at least 50 nautical miles.

1. Contact a ground station in close proximity.
2. Press the **COM** volume knob to select manual squelch
3. Listen for any unusual electrical noise, which would increase the squelch threshold.

If possible, verify the communications capability on both the high, low, and mid bands of the VHF COM band. It may be required by the governing regulatory agency to verify operation of the COM transmitter and receiver at the extents of a ground facility's service volume (e.g., FAA AC 23-8A).

### 6.7.2 VOR Flight Check (GNC Only)

1. Tune a local VOR station within 50 miles.
2. Verify the audio IDENT and voice quality and verify that no objectionable electrical interference such as magneto noise is present.
3. Verify the Morse code decoder IDs the station (95% probability).
4. Fly to and from the station.
5. Verify NAV flag, TO/FROM flag, and CDI are operational.

It may be required by the governing regulatory agency to verify operation of the VOR receiver at the extents of a ground facility's service volume (e.g., FAA AC 23-8A).

### 6.7.3 ILS Flight Check (GNC Only)

1. Tune an ILS at a local airport.
2. Verify the audio IDENT and audio quality and verify that no objectionable electrical interference such as magneto noise is present.
3. Verify the Morse code decoder IDs the station (95% probability).
4. Fly the approach.
5. Verify NAV flag, GS flag, and CDI and VDI are operational.

## 6.8 Software Loading



### NOTE

*Garmin recommends the use of a USB 2.0 compatible flash drive for updating databases and software on the GTR/GNC. The flash drive must be formatted as FAT32.*

If the software is out of date, go to the [Dealer Resource Center](#) on Garmin's website and download updates to a USB flash drive. For dual GTR/GNC installations, the software loading procedures must be carried out on both units.

### 6.8.1 Creating a GTR/GNC Software Loader USB Flash Drive



### NOTE

*The application to create a loader card requires Windows 2000, XP, Vista, or Windows 7. There is no Mac support at this time.*

1. Go to the [Dealer Resource Center](#) on Garmin's website.
2. Download the applicable GTR/GNC software to your PC.
3. Ensure the flash drive is inserted into the USB slot of the PC.
4. Run the executable file that was downloaded and follow the prompts on the screen to create the software loader USB drive.
5. Select finish to complete the process after the card has been created.
6. Remove the flash drive from the USB slot. The GTR/GNC USB loader drive is now ready to use.

### 6.8.2 GTR/GNC Software Compatibility

Table 6-16 lists the software versions compatible with subsystems within the GTR/GNC.

**Table 6-16 Software Compatibility**

Display Software Version	COM Software Version	COM FPGA Version	NAV Software Version [1]	NAV FPGA Version [1]
2.02 or earlier	2.13 or earlier	2.3	6.02	1.1
2.10 or later	2.20 or later	2.4	6.02	1.1

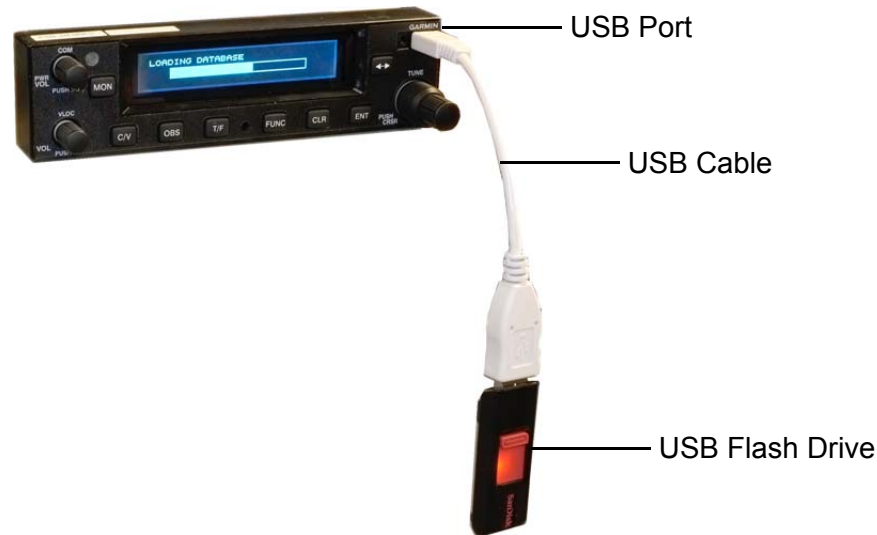
[1] NAV software and NAV FPGA are only applicable to the GNC.



### 6.8.3 Loading Software to the GTR/GNC

To load software to the GTR/GNC, ensure that the unit is powered on in configuration mode.

1. Insert the supplied USB cable into the USB port of the GTR/GNC.
2. Insert the flash drive containing the software update into the other end of the cable. See figure 6-27.



**Figure 6-27 USB Update Progress**

3. From the CONFIG MODE page, select the software to be updated (System Display, COM, or NAV). Each software item must be separately updated. After update, verify the software updates loaded successfully.

#### **System Display Software Update**

1. Turn the outer knob to SYS CONFIGURATION.
2. Turn the inner knob to DISPLAY UPDATE.
3. Press **ENT**.
4. Press **ENT** again.
5. Verify the available display software update is displayed.
6. Press **ENT** again to begin the software update process.

#### **NAV Software Update**

1. Turn the outer knob to NAV CONFIGURATION.
2. Turn the inner knob to NAV UPDATE.
3. Press **ENT**.
4. Press **ENT** again.
5. Verify the available NAV software update is displayed.
6. Press **ENT** again to begin the software update process.

## COM Software Update

1. Turn the outer knob to COM CONFIGURATION.
2. Turn the inner knob to COM UPDATE.
3. Press **ENT**.
4. Press **ENT** again.
5. Verify the available COM software update is displayed.
6. Press **ENT** again to begin the software update process.

### 6.8.4 Load Database

Database updates require the GTR/GNC to be in normal mode. Verify the unit's database version to what was downloaded from [www.flyGarmin.com](http://www.flyGarmin.com).



#### NOTE

*See section 1.11 for instructions on loading the frequency database onto the USB flash drive.*

1. Insert the supplied USB cable into the USB port of the GTR/GNC.
2. Insert the flash drive containing the database update into the other end of the cable.
3. Press **FUNC**.
4. Turn the outer knob to SYS CONFIGURATION.
5. Turn the inner knob to LOAD DATABASE.
6. Press **ENT**.
7. Press **ENT** to begin update.



**Figure 6-28 Database Update Page**

8. Press **FUNC** to verify database information.
9. Turn the outer knob to SYS CONFIGURATION.
10. Turn the inner knob to DATABASE INFO.
11. Press **ENT**.



**Figure 6-29 Database Info Page**

## **7 CONTINUED AIRWORTHINESS**

Maintenance of the GTR 225, GTR 225A, GTR 225B, GNC 255A, or GNC 255B is “on condition” only. For regulatory periodic functional checks, refer to approved aircraft maintenance manuals or manual supplements for actual aircraft maintenance requirements.

## APPENDIX A ENVIRONMENTAL QUALIFICATION FORM

Visit the Garmin [Dealer Resource Center](#) for RTCA/DO-160F Environmental Qualification Forms (EQFs).

The GTR Series (GTR 225/225A/225B) EQF is P/N 005-00658-02.

The GNC Series (GNC 255A/255B) EQF is P/N 005-00658-03.

## APPENDIX B GTR/GNC DATA FORMAT

### B.1 RS-232 Aviation Format

#### B.1.1 Electrical Interface

The I/O signals are compatible with RS-232C. Data is generated at 9600 baud with a word length of 8 bits, one stop bit, and no parity.

#### B.1.2 General Aviation Output Format

The GTR/GNC RS-232 data has the following general format:

- STX - ASCII start-of-text character (02 hex)
- t1s - Type 1 output sentences (see following paragraphs for description)
- t2s - One or more type 2 output sentences (see following paragraphs for description)
- ETX - ASCII end-of-text character (03 hex)

#### B.1.3 Aviation Output Sentence Type 1

The Type 1 output sentences have the following general format:

- id - item designator (single ASCII alphabetic character)
- dddd - item data (1 to 10 printable ASCII characters)
- CR - ASCII carriage return character (0D hex)
- LF - ASCII line feed character (0A hex)[1]

**Note:**

[1] The line feed character is not output if the RS-232 port is configured as “Aviation Output 2.”

Each Type 1 sentence is output by the GTR/GNC approximately once every second.

The track, desired track, and bearing to waypoint angles, and the magnetic variation are output according to the current mode of the GTR/GNC (automatic magnetic heading, magnetic variation computed at last known position; true heading, magnetic variation of E00.0°; or user-defined magnetic heading, magnetic variation as entered by user).

Table B-1 describes the Type 1 output sentence item designator (id) and item data (dddd) fields. If data for these sentences is invalid or unavailable, dashes ("-") are used to fill in all non-blank character positions.

**Table B-1 Aviation Output Sentence Format**

Ident (1 byte)	Data (10 bytes) 1 2 3 4 5 6 7 8 9 0	Description
z	a a a a a	Current GPS altitude in feet [1]
A	s d d m m h h	Current latitude, where: s - N (north) or S (south) dd - degrees mm - minutes hh - hundredths of minutes
B	s d d d m m h h	Current longitude, where: s - E (east) or W (west) ddd - degrees mm - minutes hh - hundredths of minutes
C	d d d	Track in whole degrees
D	s s s	Ground speed in knots
E	d d d d d	Distance to waypoint in tenths of nautical miles
G	s n n n n	Cross track error, where: s - L (left) or R (right) of course nnnn - error in hundredths of nautical miles
I	d d d d	Desired track in tenths of degrees
K	c c c c c	Destination waypoint identifier (will be blank filled on right if less than 5 characters in identifier)
L	d d d d	Bearing to destination waypoint in tenths of degrees
Q	s d d d	Magnetic variation, where: s - E (east) or W (west) ddd - tenths of degrees
S	- - - - f	NAV valid flag status, where: f - N (NAV flagged) or - (NAV valid)
T	- - - - - - - - -	Warnings status, only data transmitted are dashes (-). Used to indicate end of Type 1 sentences.
l (lower case Lima)	d d d d d d	Distance to destination waypoint in tenths of nautical miles.

**Note:**

[1] The altitude is not output if the RS-232 port is configured as "Aviation Output 2."

### B.1.4 Aviation Output Sentence Type 2

The GTR/GNC Type 2 aviation output sentence has the following general format:

id	- item designator (3 ASCII characters)
seq	- sequence number (1 binary byte)
wpt	- waypoint identifier (5 ASCII characters)
lat	- waypoint latitude (3 binary bytes)
lon	- waypoint longitude (4 binary bytes)
mvar	- magnetic variation at waypoint (2 binary bytes)
CR	- ASCII carriage return character (0D hex)
LF	- ASCII line feed character (0A hex)

Each waypoint in the route being navigated by the interfacing equipment has a Type 2 sentence output by the interfacing navigation equipment approximately once every second.

If no route is being navigated by the interfacing navigation equipment (i.e., the active route is empty), the following Type 2 sentence is output approximately once every second:

id	- item designator (3 ASCII characters; route sequence number is "01")
seq	- sequence number (1 binary byte; last waypoint flag is set; route sequence number is 1)
CR	- ASCII carriage return character (0D hex)
LF	- ASCII line feed character (0A hex)

Table B-2 describes the Type 2 aviation output sentence item designator (id), sequence number (seq), waypoint identifier (wpt), waypoint latitude (lat), waypoint longitude (lon), and magnetic variation at waypoint (mvar) fields.

**Table B-2 Type 2 Aviation Output Sentence Format**

Field	Byte	Format 7 6 5 4 3 2 1 0	Description
id	1 2-3		ASCII character "w" (77 hex) Two ASCII numeric characters representing route sequence number of waypoint (01 to 31)
seq	1	x l a n n n n n n	x - undefined l - 1 if last waypoint in route a - 1 if active to waypoint nnnnn - route sequence number of waypoint (unsigned binary)
wpt	1-5		Destination waypoint identifier (will be blank filled on right if less than 5 characters in identifier)
lat	1 2 3	s d d d d d d d x x m m m m m m x h h h h h h h	s - 0 (north) or 1 (south) ddddddd - latitude degrees (unsigned binary) xx - undefined mmmmm - latitude minutes (unsigned binary) x - undefined hhhhhhh - hundredths of latitude minutes (unsigned binary)
lon	1 2 3 4	s x x x x x x x d d d d d d d d x x m m m m m m x h h h h h h h	s - 0 (east) or 1 (west) xxxxxxx - undefined ddddddd - longitude degrees (unsigned binary) xx - undefined mmmmm - latitude minutes (unsigned binary) x - undefined hhhhhhh - hundredths of latitude minutes (unsigned binary)
mvar	1-2		Two's complement binary in 16ths of degrees. Easterly variation is positive. MSB output first.



## B.2 RS-232 NMEA Data Format

### B.2.1 Electrical Interface

The I/O signals are compatible with RS-232C. Data is generated at 9600 baud with a word length of 8 bits, one stop bit, and no parity.

The data format for the serial communication is:

Baud rate	9600
Data bits	8
Stop bits	1
Parity	None

### B.2.2 Message Formats

All messages conform to the NMEA 0183 proprietary message format as follows. All characters will be standard ASCII characters. No binary data characters are used.

“\$”	.....	Start of message character, ASCII “\$” (024h).
“P”	.....	Proprietary message identifier.
“GRM”	.....	Garmin company identifier.
c	.....	Message class identifier; Identifies a message as either a COMM or NAV message. The GTR and COM portion of the GNC use “C”, while message for the NAV portion of the GNC use “V.”
nn	.....	Message identifier, two-digit number in ASCII characters.
d....d	.....	Message data characters defined for each message.
chksum	.....	Message checksum, including message identifier (nn) through data characters (d....d). The two-digit checksum is generated by adding all values of valid characters together, ignoring carry (if any). This value is converted into two encoded hex characters (30h-3Fh). [1]
<CR>	.....	ASCII carriage return (0Dh).
<LF>	.....	ASCII line feed (0Ah).

The maximum message length, including the start of message character (“\$”) and the end of message <CR><LF> sequence, is 25 bytes.

**Note:**

- [1] Encoded hex: each character consists of 4 bits of data placed in the low order nibble +30h. For example, the 8-bit value 5Fh would be encoded as two characters with values of 35h and 3Fh, which map to the ASCII characters “5” and “?”, respectively.

### B.2.3 Message Output Rate

The GTR/GNC will output the following messages at the specified rates:

- CDI, VDI, and Flags at 10Hz (high rate).
- Decoded OBS Setting at 10Hz (high rate).
- Radial from Active VOR at 10Hz (high rate).
- Decoded Station Identifier at 1Hz (low rate).
- NAV Receiver Status at 1Hz (low rate).
- COM Transceiver Status at 1Hz (low rate).

### B.2.4 Message Definitions

#### B.2.4.1 Input Messages

##### B.2.4.1.1 Request Data Output

This input command is used to request an output message to be sent by the GTR/GNC. Message data may be specified. There are a few important things to keep in mind:

- The GTR/GNC will flag the specified message for output when it receives the request. There will be a lag between the time the message is flagged for output and the time it is actually output. If another request for the same message is received in this period, then the previous request will be lost. The amount of lag depends on the number of messages that are consecutively flagged for output.
- Use of unsupported output identifiers will not generate a Communication Error message.

#### Message format (GNC NAV requests):

- “V” .....Message class. This is a GNC NAV request.
- “24” .....Message identifier.
- ii .....Output identifier of requested message, two ASCII characters. 29 = Request NAV Audio. 40 = Request NAV Volume. 41 = Request GNC Status.
- “000” .....Reserved.

#### Message format (GTR/GNC COM requests):

- “C” .....Message class. This is a GTR/GNC COM request.
- “06” .....Message identifier.
- ii .....Output identifier of requested message, two ASCII characters. 02 = Request COM Audio Volume. 03 = Request COM software version. 13 = Request GTR Status.
- d .....Message sub-id; set to (ASCII) 1 for Request COM Audio Volume, 0 otherwise.
- “00” .....Reserved.

#### Example messages:

```
$PGRMV2429000<chksm><CR><LF>
```

Request the GNC to send the current NAV Audio configuration.

```
$PGRMC0613000<chksm><CR><LF>
```

Request the GTR/GNC to send the current COM status.

### B.2.4.1.2 Set Active COM Frequency and Transceiver Function.

This message is used to set the Active COM frequency as well as the COM transceiver function.

#### Message format:

“C” .....Message class. This is a GTR/GNC COM message.  
 “00” .....Message identifier.  
 mk .....Active COMM frequency:  
     m = desired frequency in MHz in hexadecimal, where m = desired frequency - 30h, with desired frequency in range of 118 to 136 MHz.  
     k = desired frequency in kHz, where k = (desired frequency / 25 kHz) + 30h, with desired frequency in range of 000 to 975 kHz in 25 kHz steps.  
 a .....Transceiver function: N = normal, M = monitor, 0 = unchanged.  
 o .....8.33 kHz offset: (ASCII) 0 = 25 kHz frequency (.000); 1 = first 8.33 kHz channel offset (.005); 2 = second 8.33 kHz channel offset (.010); 3 = third 8.33 kHz channel offset (.015)

#### Example message:

```
$PGRMC00G4N0<chksm><CR><LF>
```

This example command would set the active COM frequency to 119.100 MHz and place the COMM radio in Normal receive mode. This is interpreted by noting that the ASCII “G” corresponds with 47h, +30h = 77h, converted to decimal equals 119 for the MHz portion. The kHz portion converts ASCII “4” to 34h, - 30h yields 4h, x 25 kHz steps = 100 kHz, with no 8.33 kHz channel offsets.



#### NOTE

*The GTR/GNC will check input frequencies for validity. An RS-232 serial error message output will be generated if the frequency is invalid, or an 8.33 kHz frequency is requested when the GTR/GNC is in 25 kHz channel spacing mode.*



#### NOTE

*The GTR/GNC will ignore this message while transmitting on the active COM frequency.*

### B.2.4.1.3 Set Standby COM Frequency and Transceiver Function.

This message is used to set the standby COM frequency as well as the COM transceiver function.

#### Message format:

“C” .....Message class. This is a GTR/GNC COM message.  
 “01” .....Message identifier.  
 mk .....Standby COMM frequency:  
     m = desired frequency in MHz in hexadecimal, where m = desired frequency - 30h, with desired frequency in range of 118 to 136MHz.  
     k = desired frequency in kHz, where k = (desired frequency / 25 kHz) + 30h, with desired frequency in range of 000 to 975 kHz in 25 kHz steps.  
 a .....Transceiver function: N = normal, M = monitor, 0 = unchanged.  
 o .....8.33 kHz offset: (ASCII) 0 = 25 kHz frequency (.000); 1 = first 8.33 kHz channel offset (.005); 2 = second 8.33 kHz channel offset (.010); 3 = third 8.33 kHz channel offset (.015)

#### Example messages:

```
$PGRMC01KFM2<chksm><CR><LF>
```

This example command would set the standby COM frequency to 123.565MHz and place the COM radio in Monitor mode. This is interpreted by noting that the ASCII “G” corresponds with 47h, +30h = 77h, converted to decimal equals 119 for the MHz portion. The kHz portion converts ASCII “F” to 46h, -30h yields 16h, x25 kHz steps = 550 kHz, add 3 8.33 channels = 565 kHz.



#### NOTE

*The GTR/GNC will check input frequencies for validity. An RS-232 serial error message output will be generated if the frequency is invalid, or an 8.33 kHz frequency is requested when the GTR/GNC is in 25 kHz channel spacing mode.*

### B.2.4.1.4 Set COM Volume Level and Audio Control Parameters

This input is used to set the volume level for the headphone output, and various audio controls parameters.

#### Message format:

“C” .....Message class. This is a GTR/GNC COM message.  
 “02” .....Message ident.  
 n .....Data type: (ASCII) 1 = headphone, 4 = sidetone level, 9 = RF squelch  
 vv .....Volume level: 00-FFh; two encoded hex characters (30h-3Fh).

#### Example message:

```
$PGRMC0211=<chksm><CR><LF>
```

Set the speaker output volume to 1Dh out of FFh (“=” = 3Dh, -30h = Dh).

#### **B.2.4.1.5 Select Squelch Override**

This input is used to turn the manual squelch on and off.

##### **Message format:**

“C” .....Message class. This is a GTR/GNC COM message.

“03” .....Message ident.

n .....Squelch test: (ASCII) 0 = automatic; 1 = manual override (displays “SQ”).

##### **Example message:**

```
$PGRMC030<chksm><CR><LF>
```

Set the squelch to normal operation.

#### **B.2.4.1.6 Set COM Channel Spacing**

This input is used to adjust the configured channel spacing for COM frequencies.

##### **Message format:**

“C” .....Message class. This is a GTR/GNC COM message.

“13” .....Message ident.

ss .....New spacing: (ASCII) 83 = 8.33 kHz spacing; 25 = 25 kHz spacing.

##### **Example message:**

```
$PGRMC183<chksm><CR><LF>
```

Set channel spacing to 25 kHz.

#### **B.2.4.1.7 COM Keypad Input (Display Software Version 2.10 or later)**

This input is used to press keys as though the display was on the main COM screen.

##### **Message Format:**

“C” .....Message class. This is a GTR/GNC COM message.

“19” .....Message identifier.

p .....Key press: F = Flip/flop key; M = MON key.

##### **Example message:**

```
$PGRMC19M<chksm><CR><LF>
```

Toggle the standby frequency monitor mode.

### B.2.4.1.8 Set Active NAV Frequency

This message is used to set the active NAV frequency.

**Message format:**

“V” .....Message class. This is a GNC NAV message.

“27” .....Message identifier.

mk .....Active VOR/LOC frequency:

m = desired frequency in MHz in hexadecimal, where m = desired frequency - 30h, with desired frequency in range of 108 to 117MHz.

k = desired frequency in kHz, where k = (desired frequency / 25 kHz) + 30h, with desired frequency in range of 000 to 950 kHz in 50 kHz steps, or the even numbers from 30h to 56h.

“0” .....Reserved, data in this field will be ignored.

**Example message:**

```
$PGRMV27E40<chksm><CR><LF>
```

This example command would set the active VOR frequency to 117.100MHz. This can be interpreted by noting that the ASCII “E” corresponds with 45h, +30h = 75h, converted to decimal equals 117 for the MHz portion of the command. The kHz portion converts ASCII “4” to 34h, -30h = 4h, x 25 kHz steps = 100 kHz.



**NOTE**

*The GNC will check input frequencies for validity. An RS-232 serial error message output will be generated if the frequency is invalid.*

### B.2.4.1.9 Set Standby NAV Frequency

This message is used to set the standby NAV

#### Message format:

“V” .....Message class. This is a GNC NAV message.

“28” .....Message identifier.

mk .....Standby VOR/LOC frequency:

m = desired frequency in MHz in hexadecimal, where m = desired frequency - 30h, with desired frequency in range of 108 to 117MHz.

k = desired frequency in kHz, where k = (desired frequency / 25 kHz) + 30h, with desired frequency in range of 000 to 975 kHz in 50 kHz steps, or the even numbers from 30h to 56h.

“0” .....Reserved, data in this field will be ignored.

#### Example message:

```
$PGRMV28?P0<chksm><CR><LF>
```

This example command would set the standby VOR frequency to 111.800MHz. This is interpreted by noting that the ASCII “?” corresponds with 3Fh, +30h = 6Fh, converted to decimal equals 111 for the MHz portion. The kHz portion converts ASCII “P” to 50h, -30h yields 20h, x 25 kHz steps = 800 kHz.



#### NOTE

*The GNC will check input frequencies for validity. An RS-232 serial error message output will be generated if the frequency is invalid.*

### B.2.4.1.10 Set NAV Audio Mode

This message is used to change the current NAV audio mode. There are two possible settings for this mode. The first is “IDENT”, which will suppress the voice portion of the NAV audio signal and emphasize the Morse Code station identifier. The second choice is “VOICE”, which will emphasize voice signal and suppress the Morse Code station identifier (unit will display “ID” in the upper-left corner of the NAV page).

This message is available in both normal and test modes.

**Message format:**

“V” .....Message class. This is a GNC NAV message.  
 “31” .....Message identifier.  
 a.....NAV audio mode. “I” = IDENT, “V” = VOICE

**Example message:**

```
$PGRMV31I<chksm><CR><LF>
```

Set the current NAV Audio mode to IDENT.

### B.2.4.1.11 Set Omni-Bearing Select (OBS) Value

This message is used to set the OBS value used by the GNC as the selected radial for computing the course deviation from a VOR. This message will have no effect unless the GNC is configured to use the serial port as its OBS source (“NONE” or “SERIAL”).

**Message format:**

“V” .....Message class. This is a GNC NAV message.  
 “34” .....Message identifier.  
 vvv .....OBS Value in degrees, ranging from “000” to “359.”

**Example message:**

```
$PGRMV34310<chksm><CR><LF>
```

Set the OBS value to 310 degrees.

### B.2.4.1.12 Set NAV Volume Level

This input is used to set the volume level for the NAV mixed audio.

**Message format:**

“V” .....Message class. This is a GNC NAV message.  
 “43” .....Message identifier.  
 vv .....Volume level: 00-FFh; two encoded hex characters (30h-3Fh).

**Example message:**

```
$PGRMV431=<chksm><CR><LF>
```

Set the NAV volume to 1Dh out of FFh (“=” = 3Dh, -30h = Dh).



### **B.2.4.1.13 NAV Keypad Input (Display Software Version 2.10 or later)**

This input is used to press keys as though the display was on the main NAV screen.

#### **Message Format:**

“V” .....Message class. This is a GNC NAV message.

“44” .....Message identifier.

p .....Key press: F = Flip/flop key.

#### **Example message:**

\$PGRMV44F<chksm><CR><LF>

Flip-flops the NAV active and standby frequencies.

## B.2.4.2 Output Messages

### B.2.4.2.1 COM Transceiver Status

This message is used to output the current status of the GTR/GNC COM. It will be output at the configured message rate (1 Hz) or whenever the status changes.

#### Message format:

“C”	.....	Message class. This is a GTR/GNC COM message.
“01”	.....	Message identifier.
mk	.....	Active frequency: m = MHz, where m = desired MHz frequency - 30h, ranging from 118 to 136 MHz, (i.e. 76h to 88h, A2h); k = (kHz offset / 25 kHz) + 30h, ranging from 000 to 975 kHz in 25 kHz steps.
mk	.....	Standby frequency: m = MHz, where m = desired MHz frequency - 30h, ranging from 118 to 136 MHz, (i.e. 76h to 88h, A2h); k = (kHz offset / 25 kHz) + 30h, ranging from 000 to 975 kHz in 25 kHz steps.
a	.....	Transceiver status: I = Intercom (no other status applicable) R = Normal receive M = Monitor receive T = Transmit active S = Stuck mic F = COM failure
s	.....	Squelch setting: (ASCII) 0 = automatic; 1 = manual override (“SQ” shown in upper-left corner of COM active frequency.)
hh	.....	COM channel spacing: (ASCII) 25 = 25 kHz mode; 83 = 8.33 kHz mode.
o	.....	Active frequency 8.33 kHz offset: (ASCII) 0 = 25 kHz frequency (.000); 1 = first 8.33 kHz channel offset (.005); 2 = second 8.33 kHz channel offset (.010); 3 = third 8.33 kHz channel offset (.015).
o	.....	Standby frequency 8.33 kHz offset: (ASCII) 0 = 25 kHz frequency (.000); 1 = first 8.33 kHz channel offset (.005); 2 = second 8.33 kHz channel offset (.010); 3 = third 8.33 kHz channel offset (.015)

#### Example message:

```
$PGRMC01G4LFR08303<chksm><CR><LF>
```

Active frequency is 119.100MHz, the standby frequency is 124.565MHz, unit is receiving, squelch is automatic, and the unit is in 8.33 kHz mode.



#### NOTE

*This message is output at a nominal one second rate, or faster whenever the transceiver function or status changes.*

#### B.2.4.2.2 COM Volume Level

This message is used to output the COM volume level.

**Message format:**

“C” .....Message class. This is a GTR/GNC COM message.  
02 .....Message identifier.  
“1” .....Headphone Volume.  
vv .....Volume level: 00-FFh; use encoded hex (30h-3Fh).

**Example message:**

```
$PGRMC02130<chksm><CR><LF>
```

The headphone volume level is 30h out of FFh.

#### B.2.4.2.3 COM Software Version

This message is used to output the COM module software version.

**Message format:**

“C” .....Message class. This is a GTR/GNC COM message.  
03 .....Message identifier.  
vvvv .....Software version in ASCII.

**Example message:**

```
$PGRMC030100<chksm><CR><LF>
```

COM Software version is 01.00.

#### B.2.4.2.4 GTR/GNC COM Status

This message is used to output the GTR/GNC COM Status.

**Message format:**

“C” .....Message class. This is a GTR/GNC COM message.  
13 .....Message identifier  
a.....COM needs service; (ASCII) 0 = OK, 1 = COM transmit capabilities not reliable.  
b .....COM status; (ASCII) 0 = OK, 1 = COM functions not available.  
c.....Push-to-Talk key stuck; (ASCII) 0 = OK, 1 = Stuck.  
d .....Remote Transfer stuck; (ASCII) 0 = OK, 1 = Stuck.  
e.....Remote Tune Up stuck; (ASCII) 0 = OK, 1 = Stuck.  
f.....Remote Tune Down stuck; (ASCII) 0 = OK, 1 = Stuck.  
g .....COM TX Power Limited; (ASCII) 0 = OK, 1 = Transmit power limited.  
h .....COM locked out; (ASCII) 0 = OK, 1 = Active frequency locked at 121.500 MHz.

**Example message:**

```
$PGRMC1300100001<chksm><CR><LF>
```

GTR/GNC is running and ready to accept serial input, Push-to-Talk is stuck on, and COM is locked to 121.500 MHz.

### B.2.4.2.5 GNC Status

This message is sent to indicate to the host that the GNC is running and ready to accept data on the serial port, along with the current status of alerts. It will be sent once upon startup, when requested by the host, and when an alert's status changes.

This message is only available in normal mode.

#### Message format:

- “V” .....Message class. This is a GNC NAV message.
- “41” .....Message identifier.
- a.....VLOC needs Service; (ASCII) 0 = OK, 1 = Lateral course guidance not reliable.
- b .....VLOC Status; (ASCII) 0 = OK, 1 = VLOC and Glide slope course guidance not available.
- c.....Glide Slope needs service; (ASCII) 0 = OK, 1 = Vertical course guidance not reliable.
- d .....Glide Slope Status; (ASCII) 0 = OK, 1 = Glide slope course guidance not available.
- e.....NAV remote transfer stuck; (ASCII) 0 = OK, 1 = stuck.

#### Example message:

```
$PGRMV4100010<chksm><CR><LF>
```

GNC is running and ready to accept serial input, and glide slope guidance is unavailable.

### B.2.4.2.6 CDI, VDI, and Related Flags

This message outputs the current values of the CDI, VDI, and their related flags.

Message format:

“V”	.....Message class. This is a GNC NAV message.
“21”	.....Message identifier.
cc	.....CDI deflection. An eight bit value indicating the amount of deflection of the CDI needle, represented as two encoded hex digits. [1] The CDI deflection is a twos complement signed integer in the range of –120 to 120. –100 indicates full left deflection, 0 indicates no deflection, and 100 indicates full right deflection. +/-120 indicates max left/right deflection.
gg	.....VDI deflection. An eight bit value indicating the amount of deflection of the VDI needle, represented as two encoded hexcc CDI deflection. The CDI deflection is a twos complement signed integer in the range of –120 to 120. –100 indicates full deflection upwards, 0 indicates no deflection, and 100 indicates full deflection downwards. +/-120 indicates max up/down deflection.
ff	.....Flags. Eight bits for HNAV and VNAV related flags, represented as two encoded hex digits.
	Bit 1 (lsb)Reserved
	Bit 2Localizer detect (1 = using localizer)
	Bit 3 FROM flag (1 = From)[2]
	Bit 4TO flag (1 = To)
	Bit 5GSI superflag (1 = hidden)
	Bit 6GSI valid (1 = valid)
	Bit 7NAV superflag (1 = hidden)
	Bit 8 (msb)NAV valid (1 = valid)

#### Example message:

```
$PGRMV219<64?:<chksm><CR><LF>
```

This message indicates a full left CDI deflection (-100), a full up VDI deflection (100), both the GSI and NAV flags/superflags are valid, TO flag set, FROM flag not set, using a localizer.

#### Notes:

- [1] Encoded hex: each character consists of 4 bits of data placed in the low order nibble +30h. For example, the 8-bit value 5Fh would be encoded as two characters with values of 35h and 3Fh, which map to the ASCII characters “5” and “?”, respectively.
- [2] The TO and FROM flag can not both be 1, indicating that they are both valid. They can both be zero, indicating that neither is valid. This situation will occur whenever the receiver determines that it is within the “cone of confusion” directly over a VOR, or when no signal is being received.

#### B.2.4.2.7 Decoded OBS setting

This message outputs the current OBS setting, which may be read from the NAV's internal resolver, the last valid value received over serial, or from user input to the front panel.

##### Message format:

“V” .....Message class. This is a GNC NAV message.  
“22” .....Message identifier.  
v .....Valid flag. “0” (zero) = OBS invalid/not present, “V” = OBS setting is valid.  
ddd .....Three digit OBS setting, in degrees. Values are in the range of “000” to “359.”

##### Example message:

```
$PGRMV22V170<chksm><CR><LF>
```

A valid OBS setting of 170 degrees.

#### B.2.4.2.8 Radial From Active VOR

This message outputs the current bearing from the active VOR station.

##### Message format:

“V” .....Message class. This is a GNC NAV message.  
“23” .....Message identifier.  
v .....Valid flag. “0” = bearing not valid, “V” = bearing is valid.  
dddf .....Bearing to a resolution of 1/10th of a degree. ddd = three digit bearing in degrees, ranging from “000” to “359.” f = 1/10th of a degree.

##### Example message:

```
$PGRMV23V1654<chksm><CR><LF>
```

A valid bearing of 165.4 degrees FROM the active VOR station.

### B.2.4.2.9 Decoded Station Identifier

This message outputs the decoded station identifier received on the NAV voice channel. This message will be output even if the station identifier has not been decoded yet. In this case, the message will be flagged as invalid. Note that the validity of this message does not depend on the current NAV audio mode. The decoding is done automatically regardless of this setting.

**Message format:**

- “V” .....Message class. This is a GNC NAV message.
- “25” .....Message identifier.
- v .....Valid flag. “0” = identifier is not valid, “V” = decoded station identifier is valid.
- iiii .....Decoded station identifier, five characters long. If the decoded identifier is less than five characters in length, then the trailing characters will be filled in with spaces. Identifiers are restricted to using ASCII character 0-9 and A-Z.

**Example message:**

```
$PGRMV25VISLE<Sp><chksm><CR><LF>
```

The decoded station identifier is valid and is “ISLE.”

### B.2.4.2.10 Communications Error

This message is used to indicate a communication error.

**Message format (GNC NAV error):**

- “V” .....Message class. This is a GNC NAV message.
- “27” .....Message identifier.
- e.....Error code: (ASCII)
  - “0” = input message checksum error.
  - “1” = unknown message.
  - “2” = error or mismatch in message data.

**Message format (GTR/GNC COM error):**

- “C” .....Message class. This is a GTR/GNC COM message.
- “05” .....Message identifier.
- e.....Error code: (ASCII)
  - “0” = input message checksum error.
  - “1” = unknown message.
  - “2” = error or mismatch in message data.

**Example messages:**

```
$PGRMV271<chksm><CR><LF>
```

Received an unknown NAV message.

```
$PGRMC050<chksm><CR><LF>
```

Received a COM message with an invalid checksum.

**B.2.4.2.11 NAV Receiver Status**

This message is used to output the current status of the NAV receiver. It will be output at the configured rate, and will output faster than the configured rate when the NAV receiver status changes.

**Message format:**

- “V” .....Message class. This is a GNC NAV message.
- “28” .....Message identifier.
- mk .....Active NAV frequency: m = MHz, where m + 30h = desired MHz frequency in the range of 108 to 117MHz.  
 k = desired frequency in kHz, where k = (desired frequency / 25 kHz) + 30h, with desired frequency in range of 000 to 950 kHz. Note that valid NAV frequencies only lie on 50 kHz boundaries (i.e. 108.00, 108.05, 108.10, etc.).
- mk .....Standby NAV frequency: m = MHz, where m + 30h = desired MHz frequency in the range of 108 to 117MHz.  
 k = desired frequency in kHz, where k = (desired frequency / 25 kHz) + 30h, with desired frequency in range of 000 to 950 kHz. Note that valid NAV frequencies only lie on 50 kHz boundaries (i.e. 108.00, 108.05, 108.10, etc.).
- “N” .....Reserved.

**Example message:**

```
$PGRMV28E4?PN<chksm><CR><LF>
```

Active NAV frequency is 117.100 MHz, Standby NAV frequency is 111.800 MHz.

**B.2.4.2.12 NAV Audio Mode**

This message is used to output the current NAV audio mode. There are two possible settings for this mode. There are two possible settings for this mode. The first is “IDENT”, which will suppress the voice portion of the NAV audio signal and emphasize the Morse Code station identifier (unit will display “ID” in the upper-left corner of the NAV page). The second choice is “VOICE”, which will emphasize voice signal and suppress the Morse Code station identifier.

**Message format:**

- “V” .....Message class. This is a GNC NAV message.
- “29” .....Message identifier.
- a .....NAV audio mode. “I” = IDENT, “V” = VOICE

**Example message:**

```
$PGRMV29I<chksm><CR><LF>
```

The current NAV Audio mode is “IDENT.”

**B.2.4.2.13 NAV Volume Level**

This message is used to output the NAV volume level.

**Message format:**

- “V” .....Message class. This is a GNC NAV message.
- 40 .....Message ident.
- vv .....Volume level: 00-FFh; use encoded hex (30h-3Fh).

**Example message:**

```
$PGRMV4030<chksm><CR><LF>
```

The headphone volume level is 30h out of FFh.



**Table B-3 Input Message Summary**

Class	Ident	Description	Response	Comment
C	00	Set Active COM Frequency and Transceiver Function	COM Transceiver Status	
C	01	Set Standby COM Frequency and Transceiver Function	COM Transceiver Status	
C	02	Set COM Audio Items	COM Audio Status	
C	06	Request COM data	GTR/GNC COM Status	
V	24	Request Data Output	GNC NAV Status	
V	27	Set Active VOR/LOC Frequency and Receiver Function	NAV Receiver Status	
V	28	Set Standby VOR/LOC Frequency and Receiver Function	NAV Receiver Status	
V	31	Set NAV Audio Mode	NAV Audio Mode	
V	34	Set OBS Value		
Notes	Class: "C" = GTR/GNC COM message, "V" = GNC NAV message.			

**Table B-4 Output Message Summary**

Class	Ident	Description	Length	Output Rate	Comment
V	20	Reset Status	12	At startup / Upon request	
V	21	CDI, VDI and Flags	18	High	
V	22	Decoded OBS setting	16	High	
V	23	Radial From Active VOR	17	High	
V	25	Decoded Station Identifier	18	Low	
V	27	Communications Error	13	When error detected	
V	28	NAV Receiver Status	17	status change / Low	
V	29	NAV Audio Mode	13	Upon request / status change	
V	35	Comm Transceiver Status	18	status change / Low	
V	36	Comm Software Version	17	Upon request	
Notes	Length is in bytes and includes the "\$" start of message character and the <CR><LF> end of message sequence.				

## **APPENDIX C MECHANICAL DRAWINGS**

### **C.1 Drawing List**

The following drawings are included in this section.

- Figure C-1 GTR/GNC Dimensions
- Figure C-2 GTR/GNC Mounting Rack
- Figure C-3 GNC Center of Gravity
- Figure C-4 GTR Center of Gravity
- Figure C-5 GTR/GNC Rear Connector Layout Detail
- Figure C-6 Panel Cutout Detail
- Figure C-7 GTR Mounting Rack

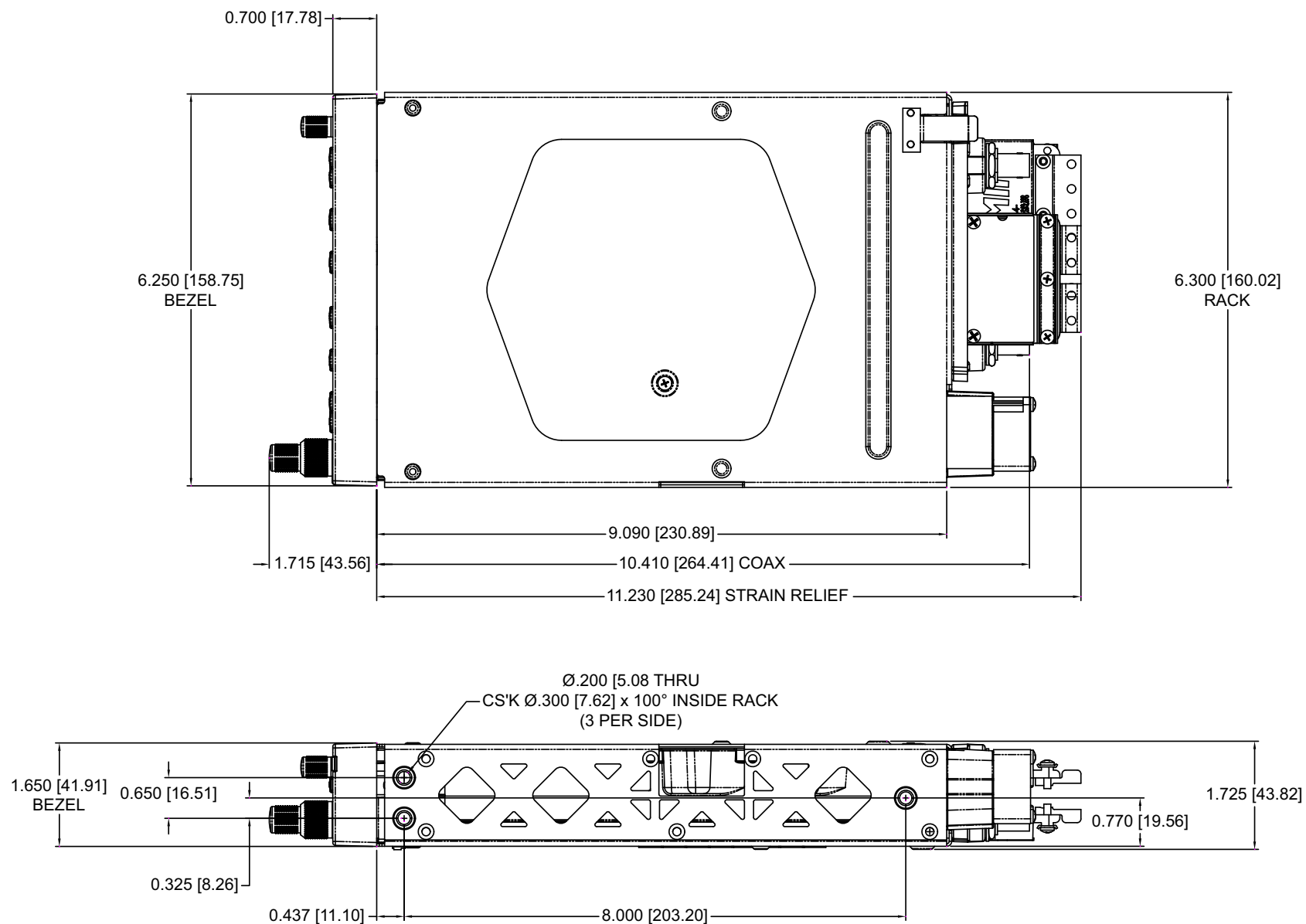
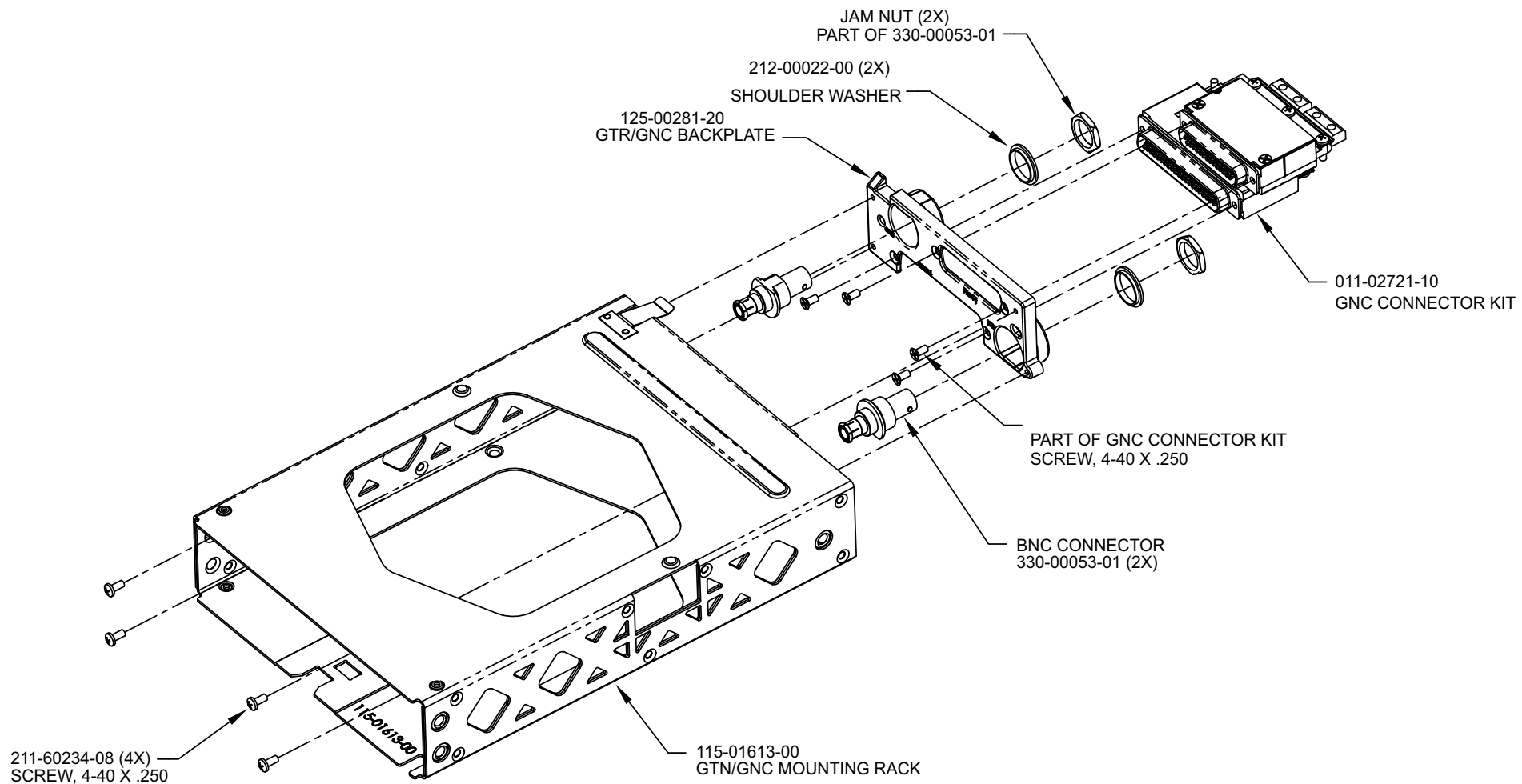
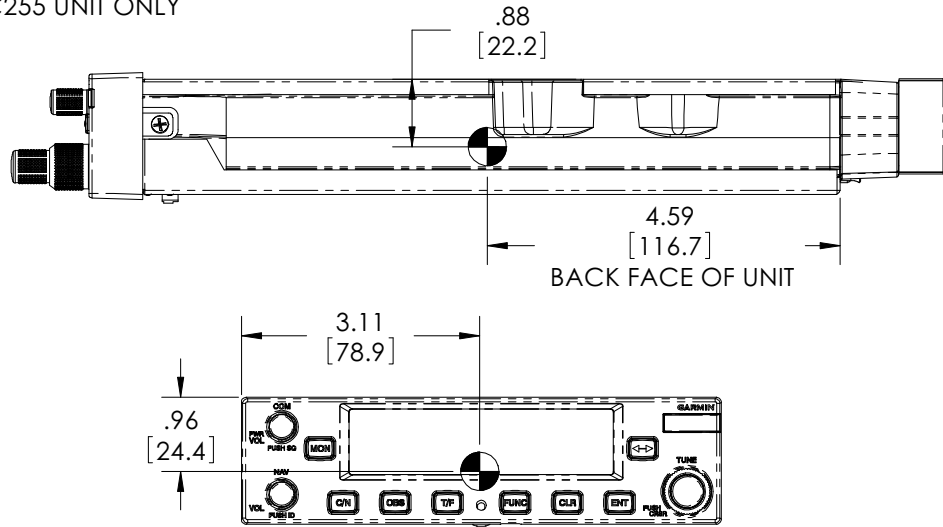


Figure C-1 GTR/GNC Dimensions

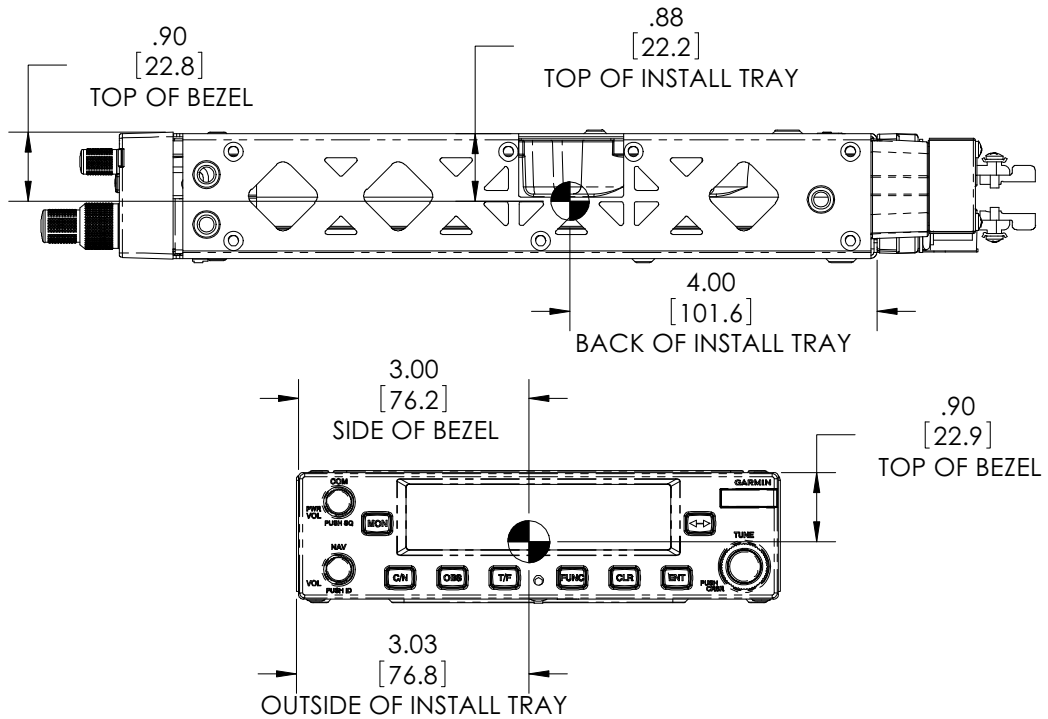


**Figure C-2 GTR/GNC Mounting Rack**

GNC255 UNIT ONLY

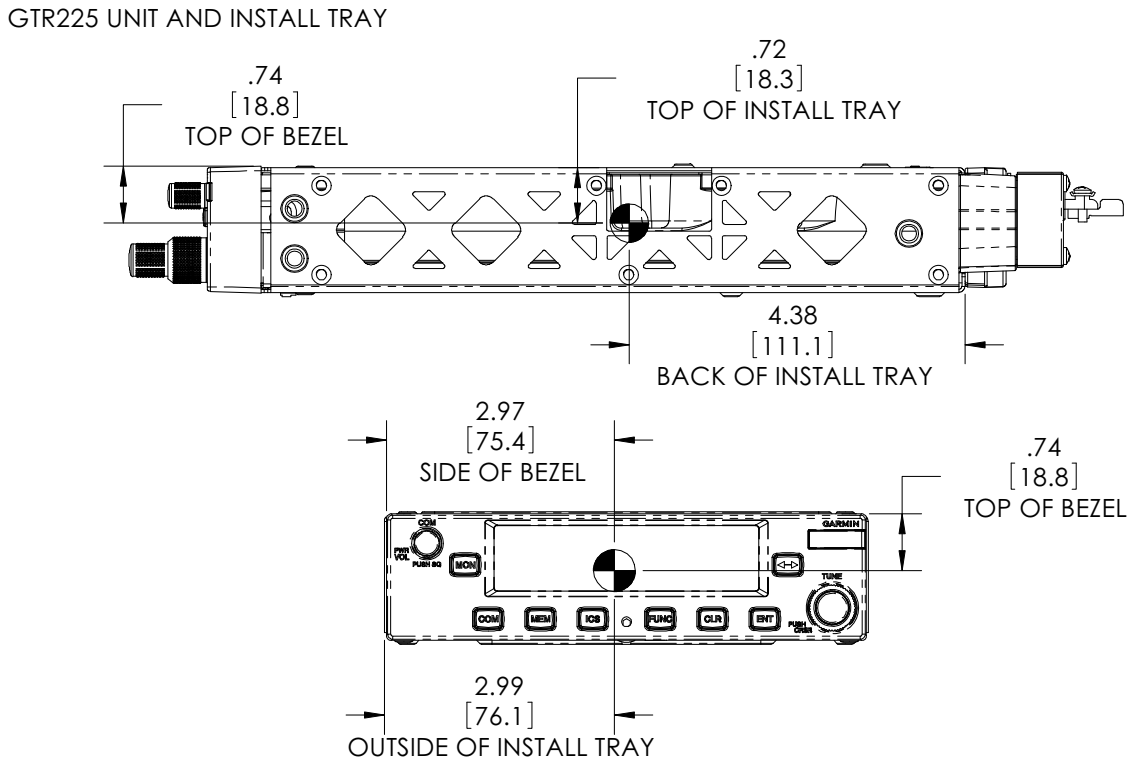
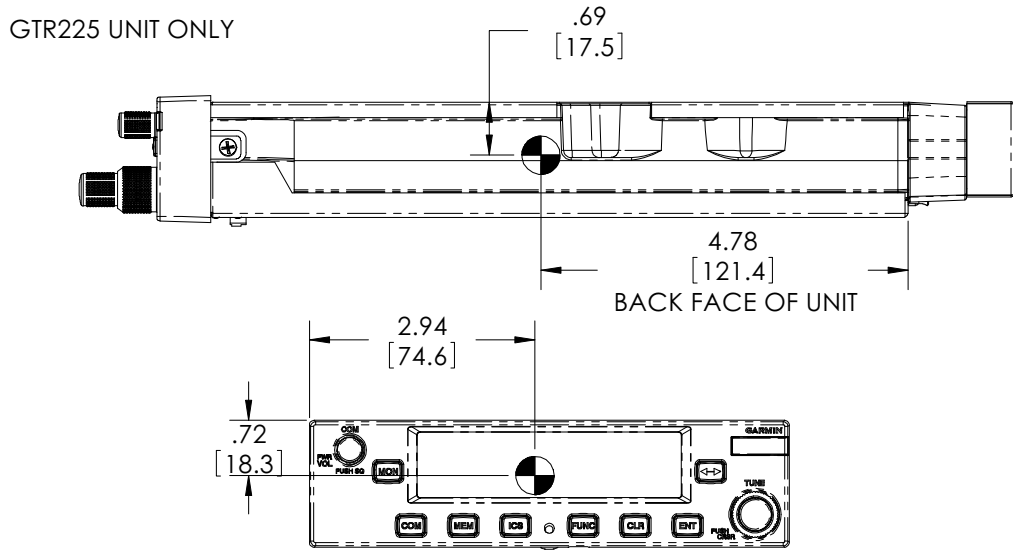


GNC255 UNIT AND INSTALL TRAY



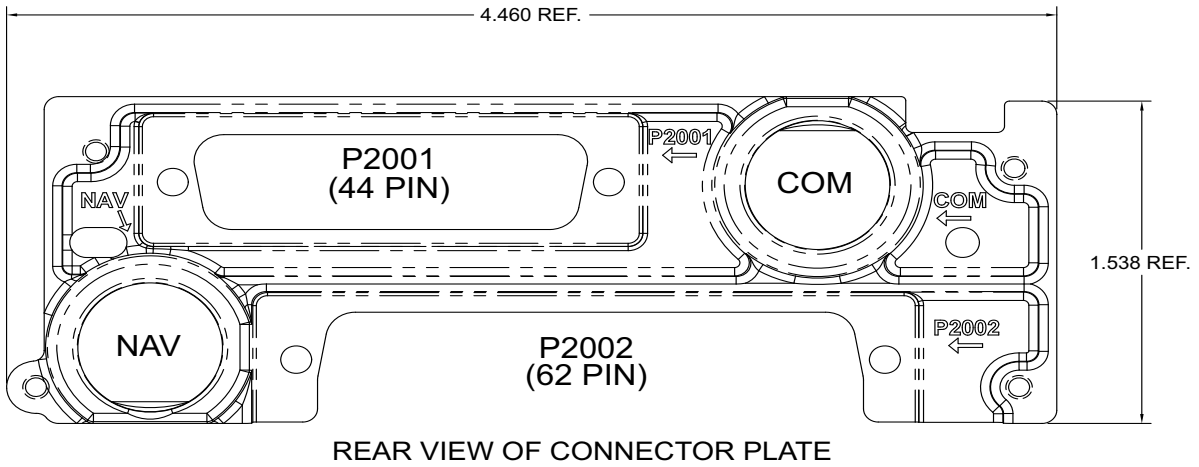
- NOTES:  
 1. DIMENSIONS ARE IN INCHES  
 2. DIMENSIONS ARE FOR REFERENCE ONLY

Figure C-3 GNC Center of Gravity

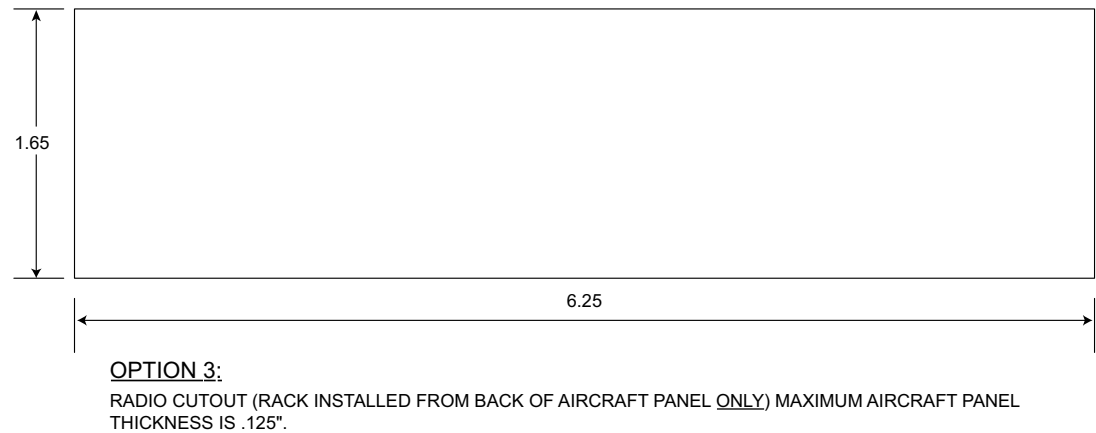
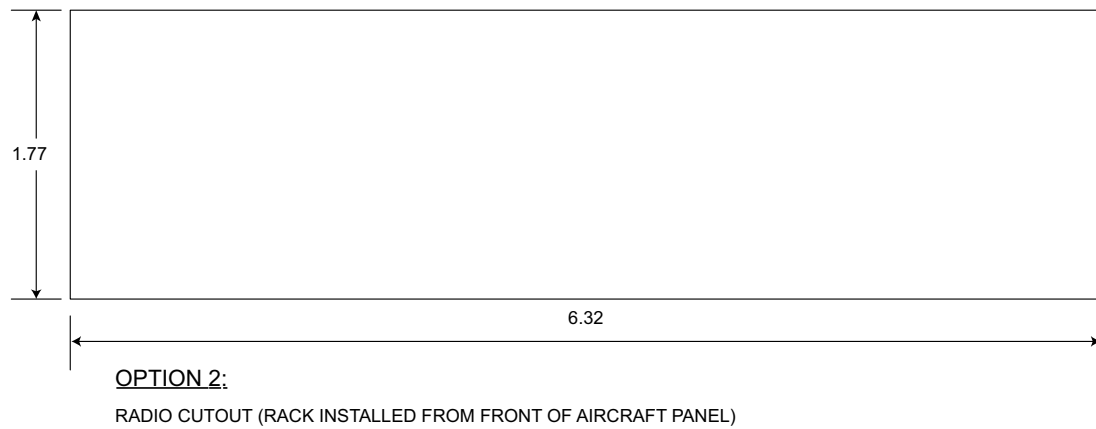
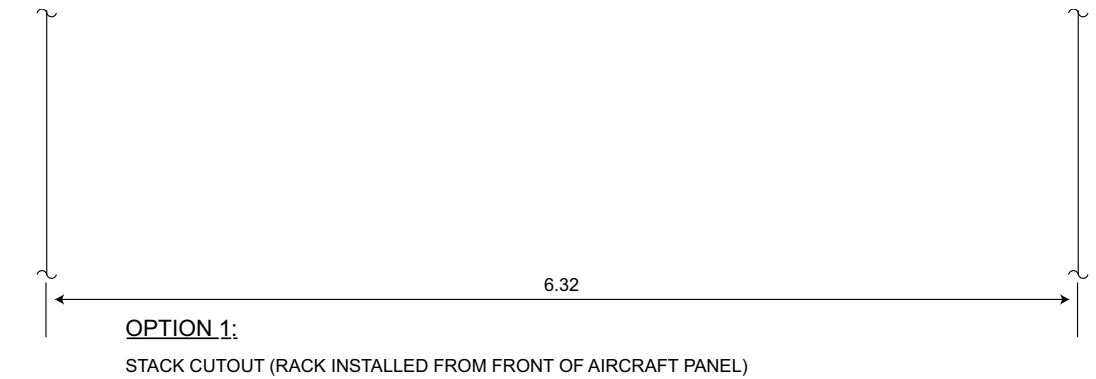


NOTES:  
 1. DIMENSIONS ARE IN INCHES  
 2. DIMENSIONS ARE FOR REFERENCE ONLY

Figure C-4 GTR Center of Gravity



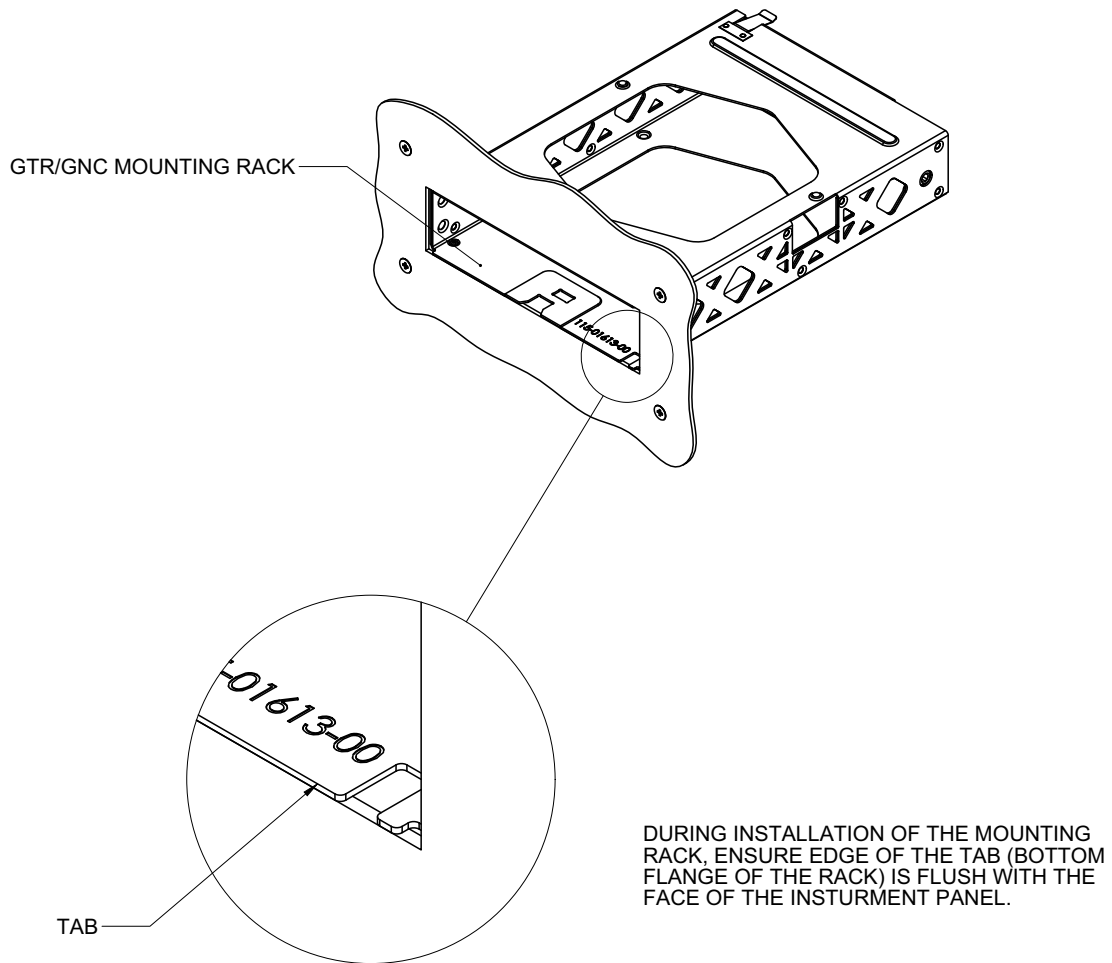
**Figure C-5 GTR/GNC Rear Connector Layout Detail**



- NOTES, ALL OPTIONS:**
1. DIMENSIONS ARE IN INCHES.
  2. IF THE FRONT LIP OF THE MOUNTING RACK IS BEHIND THE SURFACE OF THE AIRCRAFT INSTRUMENT PANEL, THE UNIT CONNECTORS MAY NOT FULLY ENGAGE.
  3. TOLERANCE:  $\pm 0.03$ "

**Figure C-6 Panel Cutout Detail**





**Figure C-7 GTR Mounting Rack**

## APPENDIX D INTERCONNECT DIAGRAMS

### D.1 Drawing List

The following drawings are included in this section:

- Figure D-1 GTR/GNC System Interface Diagram
- Figure D-2 GTR/GNC Typical Installation
- Figure D-3 GTR/GNC Power Lighting Configuration Interconnect
- Figure D-4 GTR/GNC - Antennas Interconnect
- Figure D-5 GTR/GNC - Audio Panel Interconnect
- Figure D-6 GTR/GNC - MIC Interconnect
- Figure D-7 GNC - VOR/ILS Interconnect
- Figure D-8 GTR/GNC Switches Interconnect
- Figure D-9 GNC - RMI OBI Interconnect
- Figure D-10 GNC - King Serial DME - Remote Mount Interconnect
- Figure D-11 GNC - Parallel 2 of 5 DME Tuning Interconnect
- Figure D-12 GNC - Parallel Slip Code DME Tuning Interconnect
- Figure D-13 GNC - King Serial DME - Panel Mount Interconnect
- Figure D-14 GNC - GDU 620 Interconnect
- Figure D-15 GTR/GNC - GTN 6XX/7XX, GNS 400W/500W, and GNS 480 Interconnect
- Figure D-16 GTR/GNC - GMX 200 Interconnect

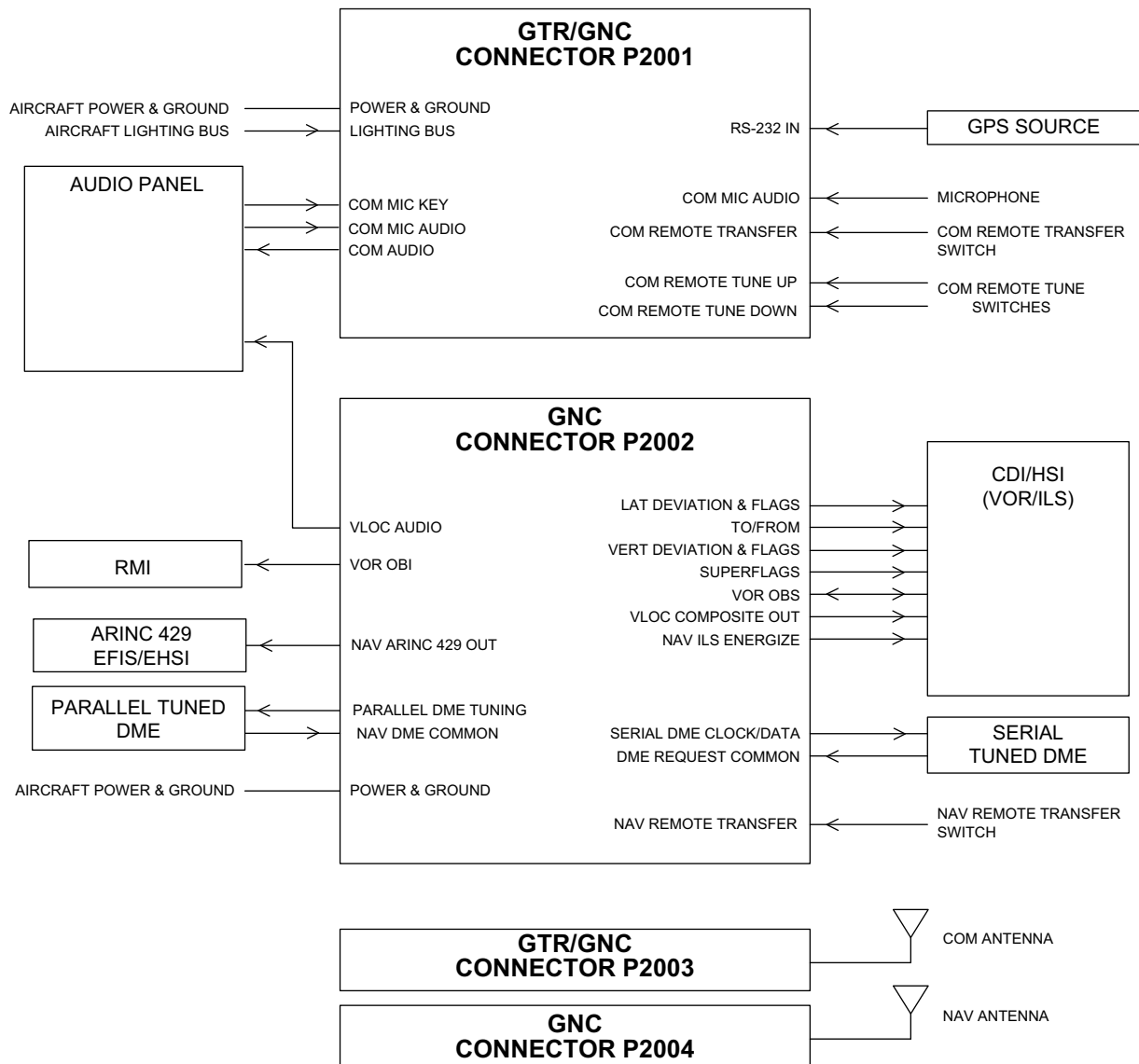
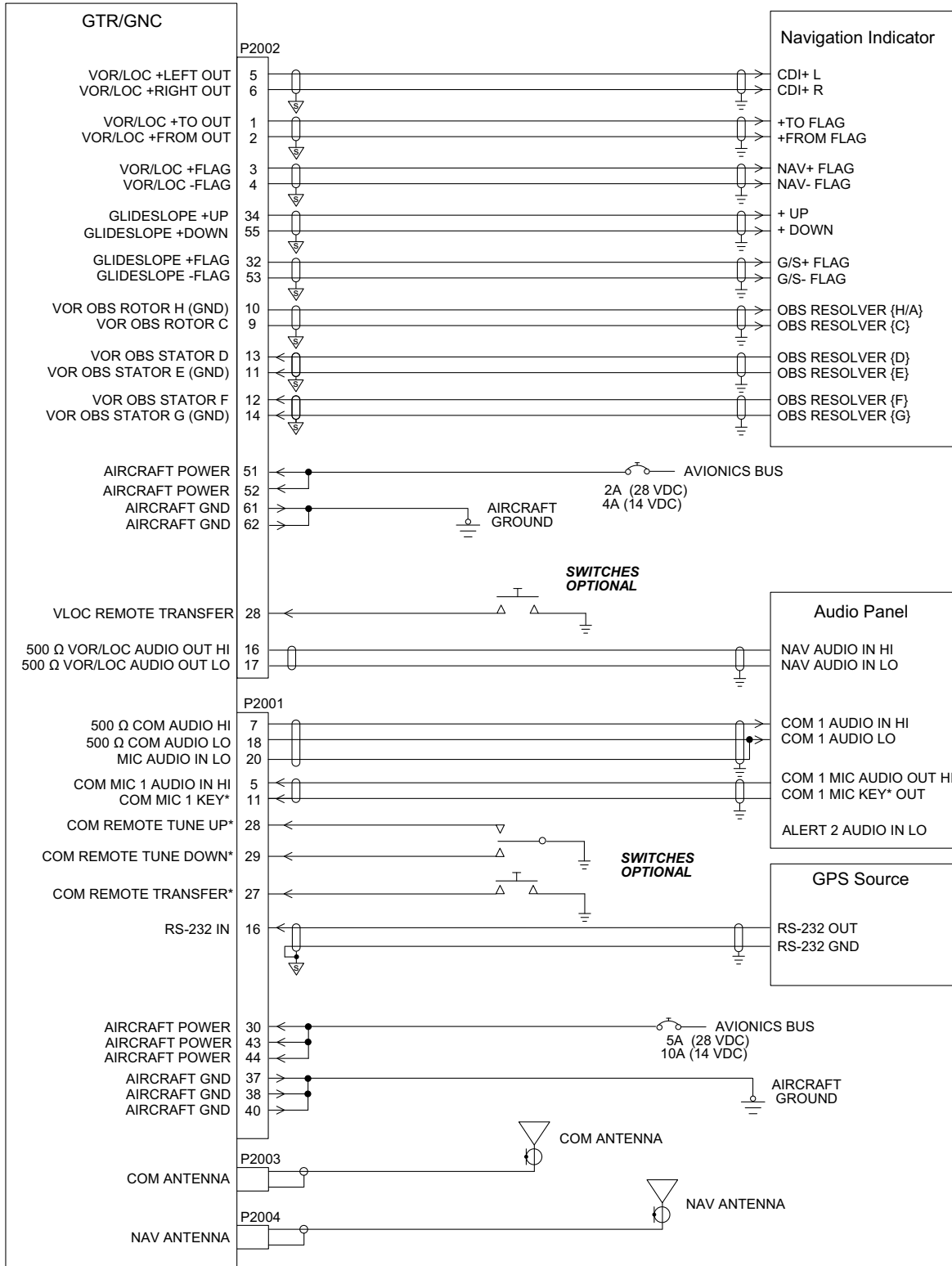




Figure D-1 GTR/GNC System Interface Diagram

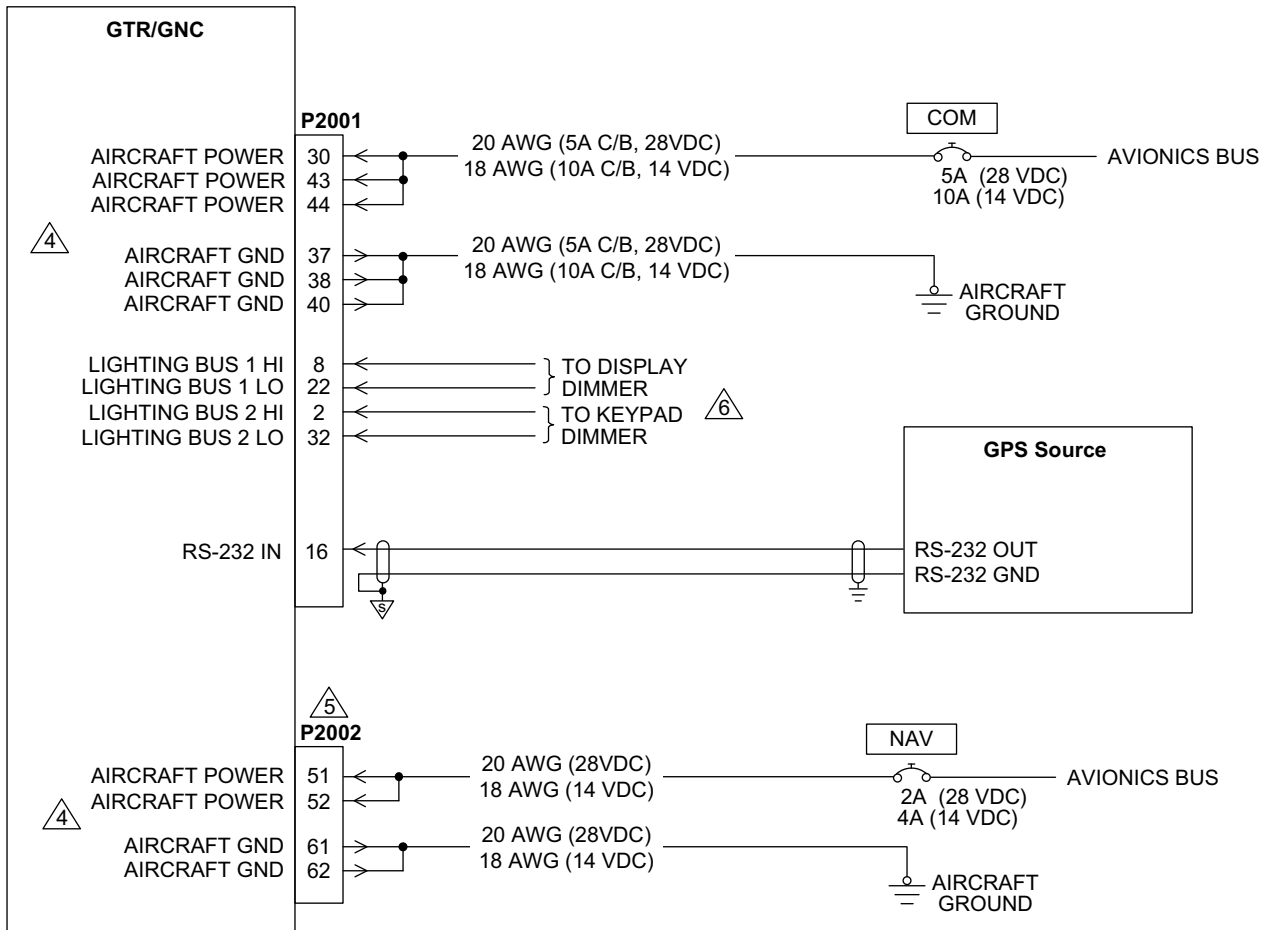


**Figure D-2 GTR/GNC Typical Installation**  
Sheet 1 of 2

## NOTES

- 1 ALL WIRES 24 AWG OR LARGER UNLESS OTHERWISE SPECIFIED.
  
- 2 GROUND DESIGNATIONS:  SHIELD BLOCK GROUND  AIRFRAME GROUND
  
- 3 AT THE GTR/GNC, CONNECT SHIELD GROUNDS TO THE CONNECTOR BACKSHELL - THE SHIELD TERMINATION LEADS SHOULD BE LESS THAN 3.0". CONNECT OTHER END OF THE SHIELD PER THE REMOTE EQUIPMENT INSTALLATION REQUIREMENTS.
  
- 4 SEE FIGURE D-3 FOR POWER AND GROUND WIRING DETAILS.

**Figure D-2 GTR/GNC Typical Installation**  
**Sheet 2 of 2**





**NOTES**

1 ALL WIRES 24 AWG OR LARGER UNLESS OTHERWISE SPECIFIED.

2 GROUND DESIGNATIONS:  SHIELD BLOCK GROUND  AIRFRAME GROUND

3 AT THE GTR/GNC, CONNECT SHIELD GROUNDS TO THE CONNECTOR BACKSHELL—THE SHIELD LEADS SHOULD BE LESS THAN 3.0". CONNECT OTHER SHIELD GROUNDS TO AIRCRAFT CHASSIS WITH AS SHORT A CONDUCTOR AS PRACTICAL.

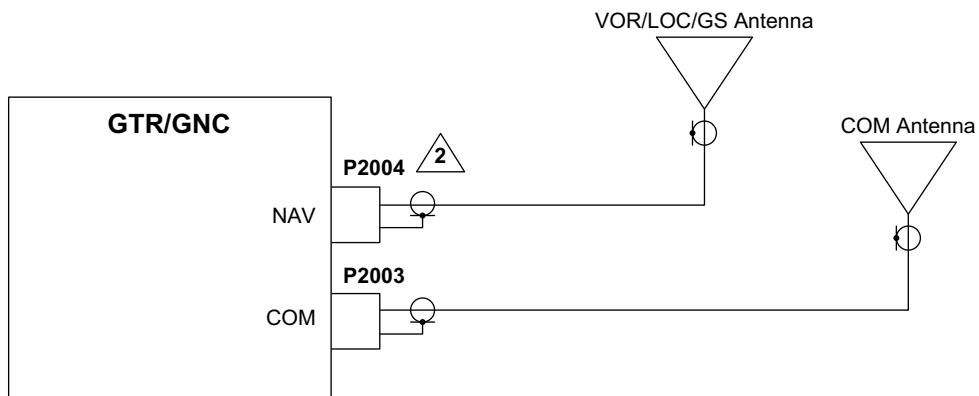
 ALL POWER LEADS AND GROUND LEADS ARE REQUIRED. 20 OR 22 AWG WIRE CAN BE USED FOR THE SPLICE. USE APPROPRIATE HEAT-SHRINK TUBING TO PROVIDE SUFFICIENT INSULATION FROM SURROUNDING CONTACTS.

 CONNECTOR P2002 IS ONLY APPLICABLE TO THE GNC 255.

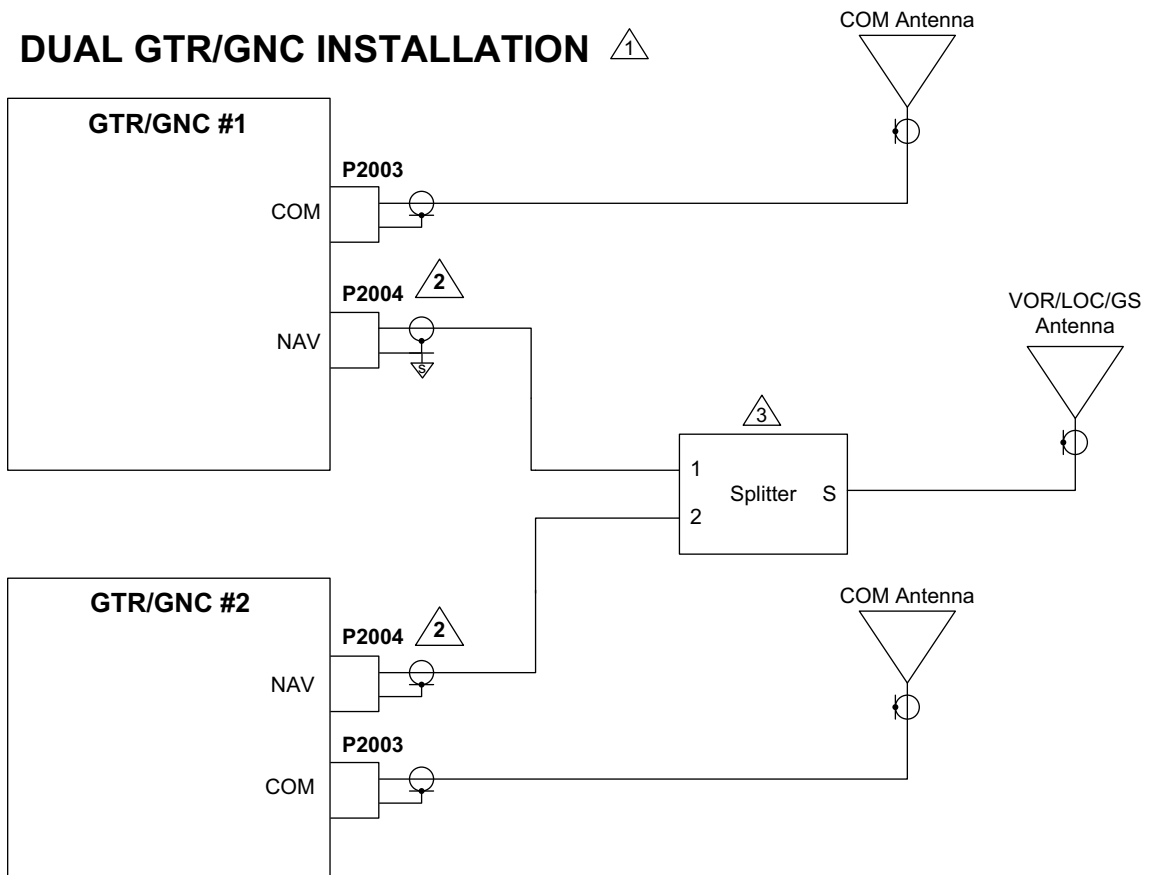
 OPTIONAL CONNECTION. LIGHTING CAN BE CONTROLLED BY THE INTEGRATED PHOTOCELL, A SINGLE LIGHTING BUS, OR DUAL LIGHTING BUSES.

**Figure D-3 GTR/GNC Power Lighting Configuration Interconnect**

**SINGLE GTR/GNC INSTALLATION** <sup>1</sup>

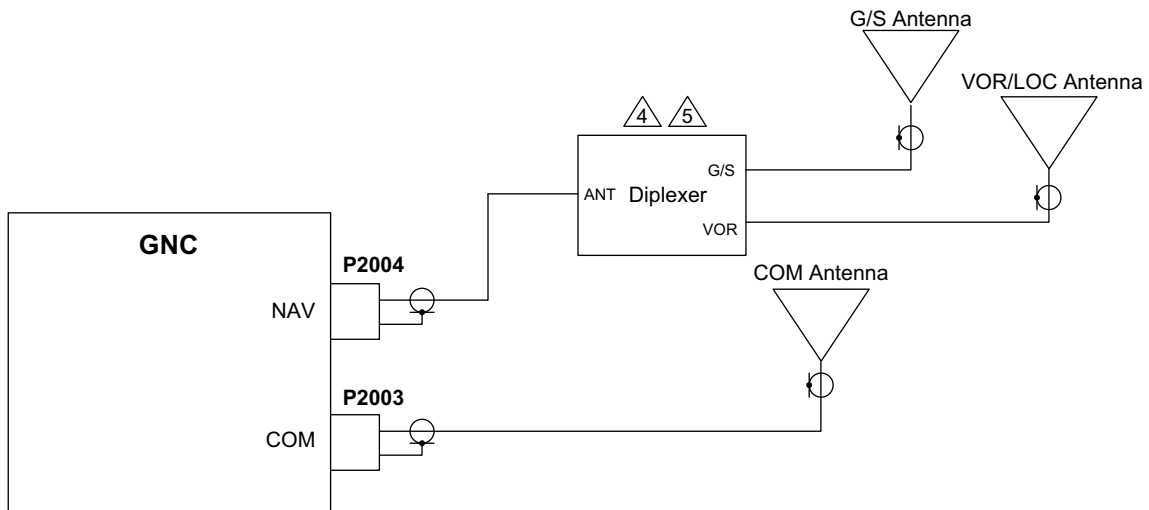


**DUAL GTR/GNC INSTALLATION** <sup>1</sup>

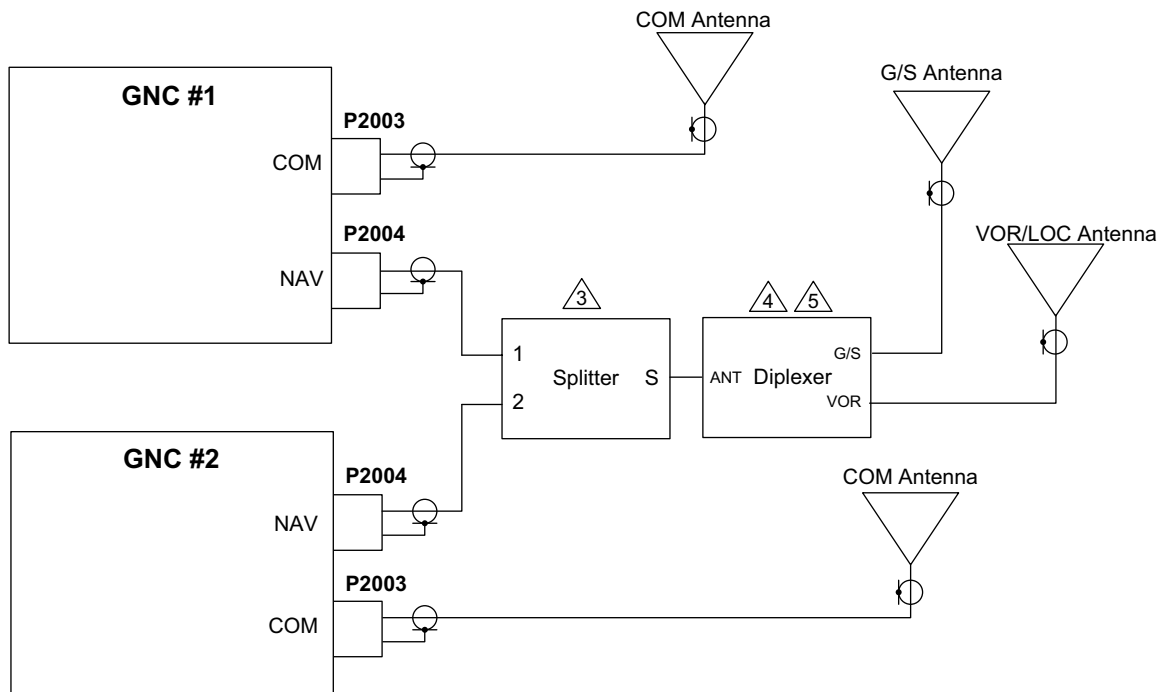


**Figure D-4 GTR/GNC - Antennas Interconnect**  
Sheet 1 of 4

**SINGLE GNC/DUAL NAV ANTENNA INSTALLATION** 



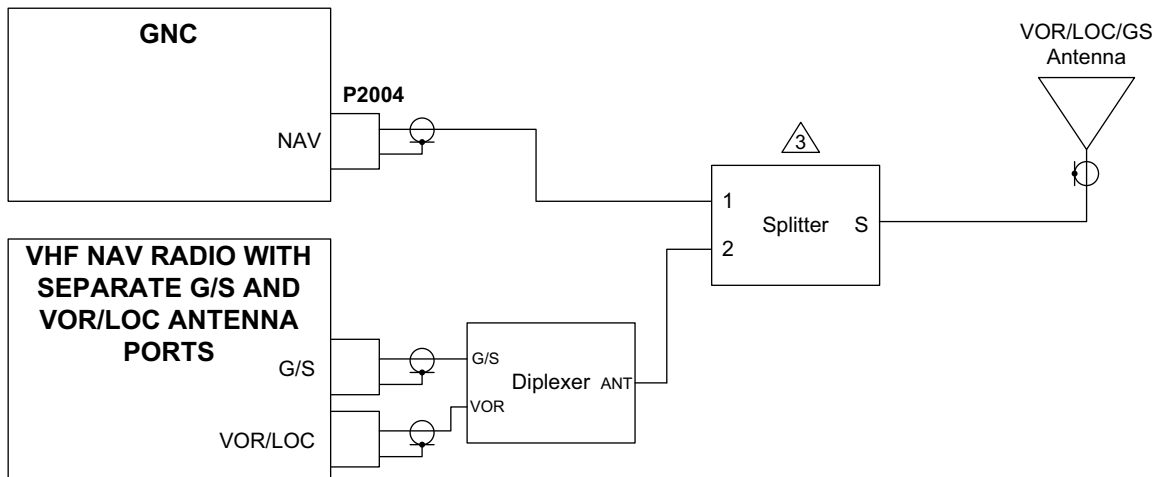
**DUAL GNC/DUAL NAV ANTENNA INSTALLATION** 



**Figure D-4 GTR/GNC - Antennas Interconnect**  
Sheet 2 of 4



### SINGLE GNC, OTHER RADIO, AND SINGLE ANTENNA



### SINGLE GNC, OTHER RADIO AND DUAL ANTENNAS

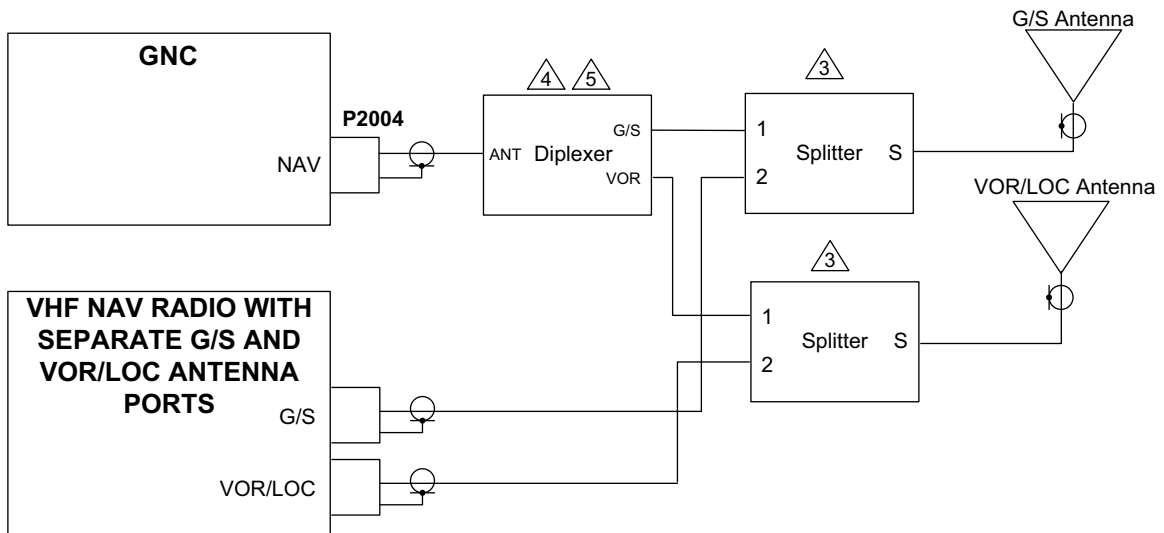


Figure D-4 GTR/GNC - Antennas Interconnect  
Sheet 3 of 4

## NOTES



SEE SECTION 3 AND SECTION 4 FOR ANTENNA CABLE SPECIFICATIONS.



P2004 NAV ANTENNA PORT IS ONLY APPLICABLE TO THE GNC MODEL.



GARMIN P/N 013-00112-00 (MINI-CIRCUITS SPLITTER P/N ZFSC-2-1B+) OR EQUIVALENT SHOULD BE USED.

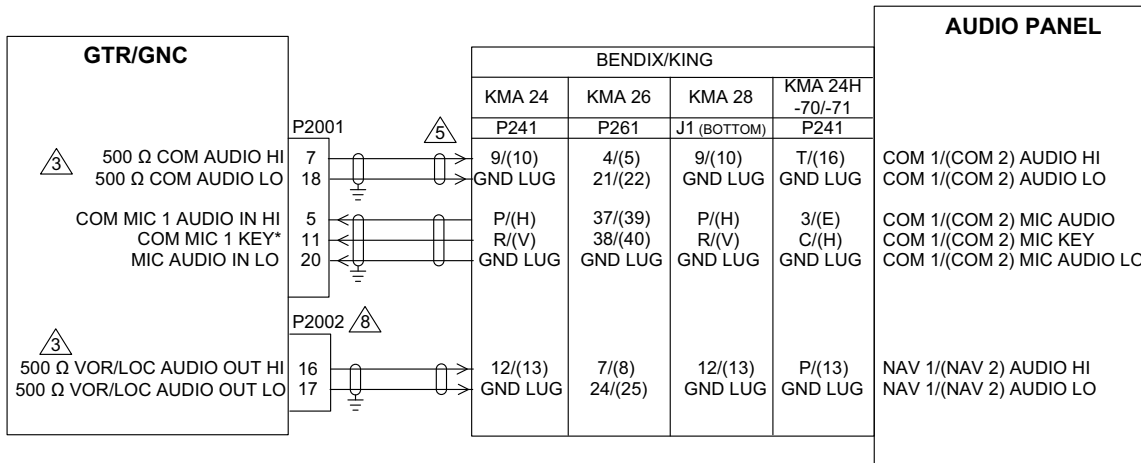
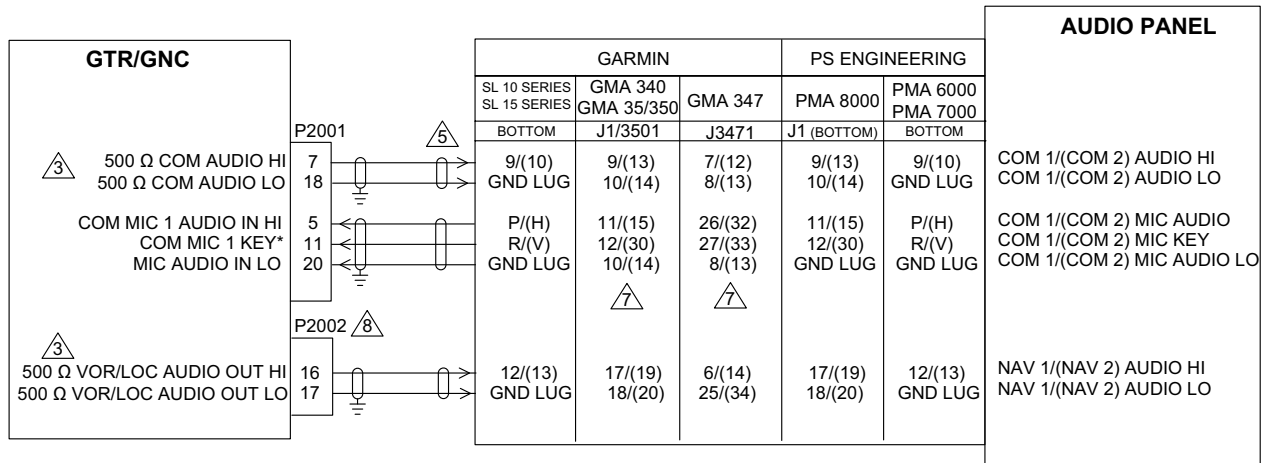


COMANT DIPLEXER P/N CI 507 MAY BE USED.









THE DIPLEXER IS INSTALLED BACKWARDS FROM TRADITIONAL APPLICATIONS. WHEN A G/S AND VOR/LOC ANTENNA IS INSTALLED, IT IS REQUIRED TO JOIN THE SIGNALS OF BOTH ANTENNAS WITH THE CI-507 DIPLEXER.

**Figure D-4 GTR/GNC - Antennas Interconnect**  
**Sheet 4 of 4**

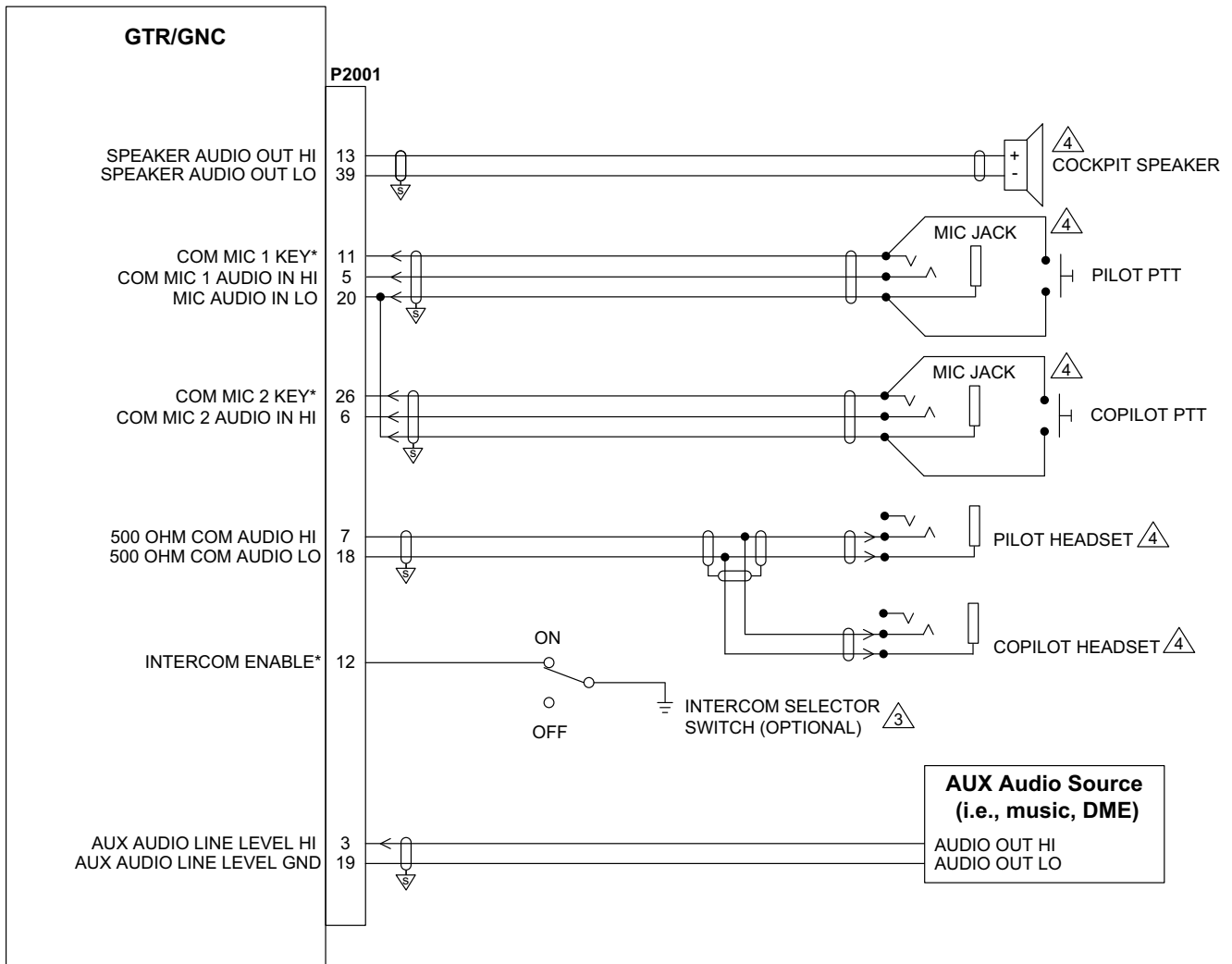


**Figure D-5 GTR/GNC - Audio Panel Interconnect**  
Sheet 1 of 2

## NOTES


- 1 ALL WIRES 24 AWG OR LARGER UNLESS OTHERWISE SPECIFIED.
- 2 GROUND DESIGNATION:  AIRFRAME GROUND
-  3 THE 500  $\Omega$  AUDIO OUTPUTS ARE BALANCED OUTPUTS, AND THE LO OUTPUTS NEED TO BE CONNECTED. IF THE AUDIO PANEL DOES NOT HAVE A LO INPUT, THE LO OUTPUT SHOULD BE CONNECTED TO A GROUND LUG AT THE AUDIO PANEL.
- 4 REFER TO MANUFACTURER'S DOCUMENTATION FOR COMPLETE PINOUT AND INTERCONNECT INFORMATION. PINOUTS OF OTHER UNITS SHOWN FOR REFERENCE ONLY.
-  5 SHIELDS FOR AUDIO CABLES SHOULD BE GROUNDED AT ONE END (WITH LEADS LESS THAN 3.0") AND LEFT FLOATING AT THE OTHER END. IF SHIELDED AUDIO CABLE IS CARRIED THROUGH A DISCONNECT, CARRY THE SHIELD GROUND THROUGH THE DISCONNECT ON A SEPARATE PIN.
-  6 CONNECTING TWO MICROPHONES TO MIC AUDIO HI/LO AT THE SAME TIME MAY RESULT IN WEAK OR DISTORTED AUDIO. MIC ISOLATION RELAYS ARE RECOMMENDED SO THAT ONLY ONE MIC IS ACTIVE AT A TIME.
-  7 SPLICE 500  $\Omega$  COM AUDIO LO AND MIC AUDIO IN LO TOGETHER INTO THE SAME PIN ON AUDIO PANEL.
-  8 THE P2002 NAV CONNECTOR IS ONLY APPLICABLE TO THE GNC MODEL.


**Figure D-5 GTR/GNC - Audio Panel Interconnect**  
**Sheet 2 of 2**




**NOTES**

1 ALL WIRES 24 AWG OR LARGER UNLESS OTHERWISE SPECIFIED.

2 GROUND DESIGNATION:  SHIELD BLOCK GROUND

 THE INTERCOM ON/OFF SWITCH IS AN OPTIONAL SWITCH THAT MAY BE INSTALLED TO ENABLE/DISABLE THE GTR/GNC INTERCOM FUNCTION. ALTERNATELY, THE INTERCOM MAY BE ENABLED/DISABLED VIA THE FUNCTION MENU OPTIONS ON THE GTR/GNC.

 ALL HEADSET, MICROPHONE, AND MUSIC PHONE PLUGS **MUST** BE ELECTRICALLY ISOLATED FROM GROUND. THIS MAY REQUIRE THE USE OF INSULATING WASHERS WHEN MOUNTING THE PHONE PLUGS. ADDITIONALLY, THE SPEAKER RETURN **MUST** BE ISOLATED FROM GROUND.

**Figure D-6 GTR/GNC - MIC Interconnect**

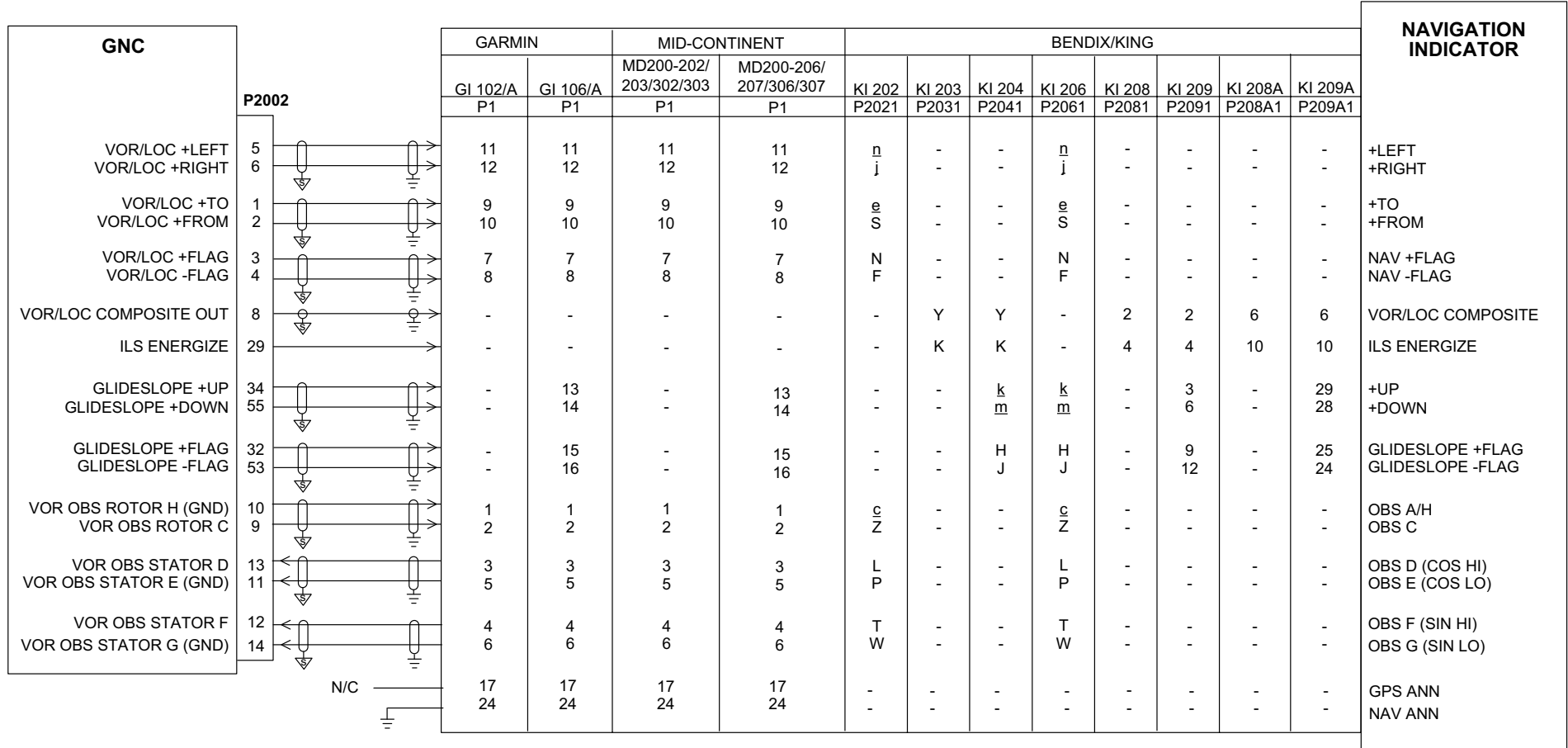


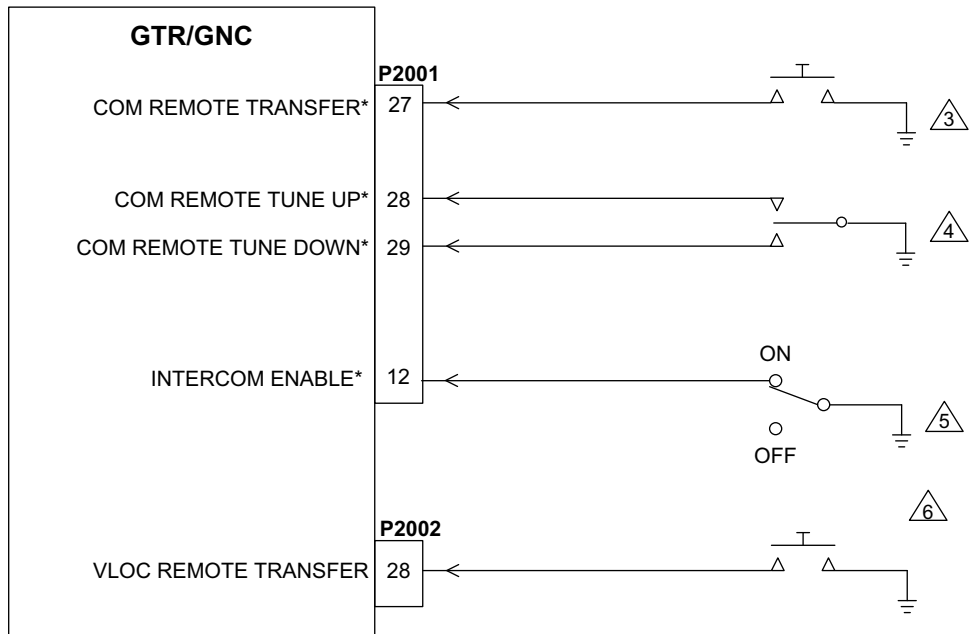


Figure D-7 GNC - VOR/ILS Interconnect  
Sheet 1 of 2

## NOTES

- 1 ALL WIRES 24 AWG OR LARGER UNLESS OTHERWISE SPECIFIED.
- 2 GROUND DESIGNATIONS:  SHIELD BLOCK GROUND  AIRFRAME GROUND
- 3 AT THE GNC, CONNECT SHIELD GROUNDS TO THE CONNECTOR BACKSHELL - THE SHIELD TERMINATION LEADS SHOULD BE LESS THAN 3.0". CONNECT OTHER END OF THE SHIELD PER THE REMOTE EQUIPMENT INSTALLATION REQUIREMENTS.
- 4 REFER TO MANUFACTURER'S DOCUMENTATION FOR COMPLETE PINOUT AND INTERCONNECT INFORMATION. PINOUTS OF OTHER UNITS SHOWN FOR REFERENCE ONLY.

**Figure D-7 GNC - VOR/ILS Interconnect  
Sheet 2 of 2**



**NOTES**

1 ALL WIRES 24 AWG OR LARGER UNLESS OTHERWISE SPECIFIED.

2 GROUND DESIGNATION:  $\perp$  AIRFRAME GROUND

3 COM REMOTE TRANSFER CAN BE USED TO TRANSFER THE STANDBY COM FREQUENCY TO THE ACTIVE COM FREQUENCY VIA REMOTE MOMENTARY SWITCH. MAY OPTIONALLY USE GRAYHILL SWITCH P/N 30-3.

4 COM REMOTE TUNE UP AND COM REMOTE TUNE DOWN CAN BE USED TO SCROLL THROUGH A LIST OF PRESET COM FREQUENCIES VIA REMOTE MOMENTARY SWITCHES. MAY OPTIONALLY USE TWO GRAYHILL SWITCHES P/N 30-3. ALTERNATIVELY, AN ON-OFF-ON SWITCH, CARLINGSWITCH P/N 62012481-0-0 CAN BE USED.

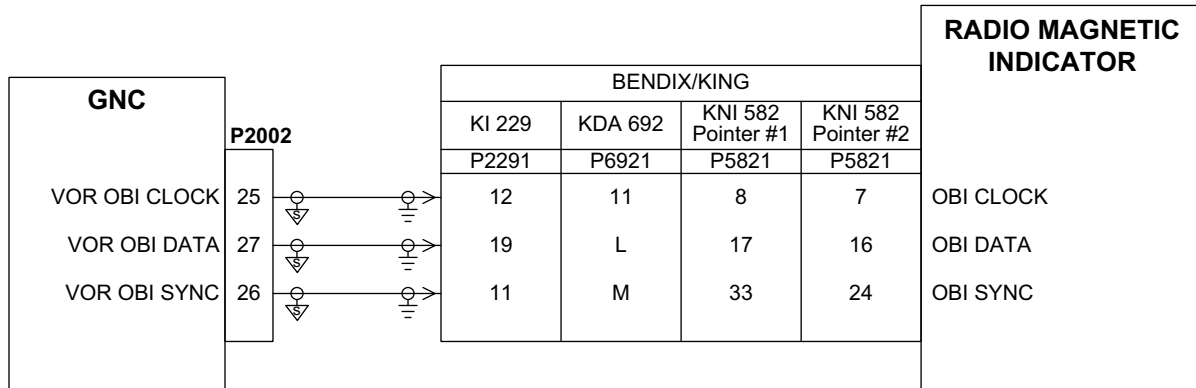
5 THE INTERCOM ON/OFF SWITCH IS AN OPTIONAL SWITCH THAT MAY BE INSTALLED TO ENABLE/DISABLE THE GTR/GNC INTERCOM FUNCTION. ALTERNATELY, THE INTERCOM MAY BE ENABLED/DISABLED VIA THE FUNCTION MENU OPTIONS ON THE GTR/GNC. MAY OPTIONALLY USE GRAYHILL SWITCH P/N 30-3.

6 VLOC REMOTE TRANSFER CAN BE USED TO TRANSFER THE STANDBY NAV FREQUENCY TO THE ACTIVE NAV FREQUENCY VIA REMOTE MOMENTARY SWITCH. MAY OPTIONALLY USE GRAYHILL SWITCH P/N 30-3.

**Figure D-8 GTR/GNC Switches Interconnect**



TYPICAL CONNECTIONS TO RMI



NOTES

- 1 ALL WIRES 24 AWG OR LARGER UNLESS OTHERWISE SPECIFIED.
- 2 GROUND DESIGNATIONS: SHIELD BLOCK GROUND AIRFRAME GROUND
- 3 AT GNC, CONNECT SHIELD GROUNDS TO THE CONNECTOR BACKSHELL -- THE SHIELD TERMINATION LEADS SHOULD BE LESS THAN 3.0". CONNECT OTHER END OF THE SHIELD PER THE REMOTE EQUIPMENT INSTALLATION REQUIREMENTS. IF NO SHIELD TERMINATION REQUIREMENT EXISTS FOR THE REMOTE EQUIPMENT, TERMINATE SHIELDS AS SHORT AS POSSIBLE, NOT TO EXCEED 3.0".
- 4 REFER TO MANUFACTURER'S DOCUMENTATION FOR COMPLETE PINOUT AND INTERCONNECT/ CONFIGURATION INFORMATION. PINOUTS OF OTHER UNITS SHOWN FOR REFERENCE ONLY.

Figure D-9 GNC - RMI OBI Interconnect

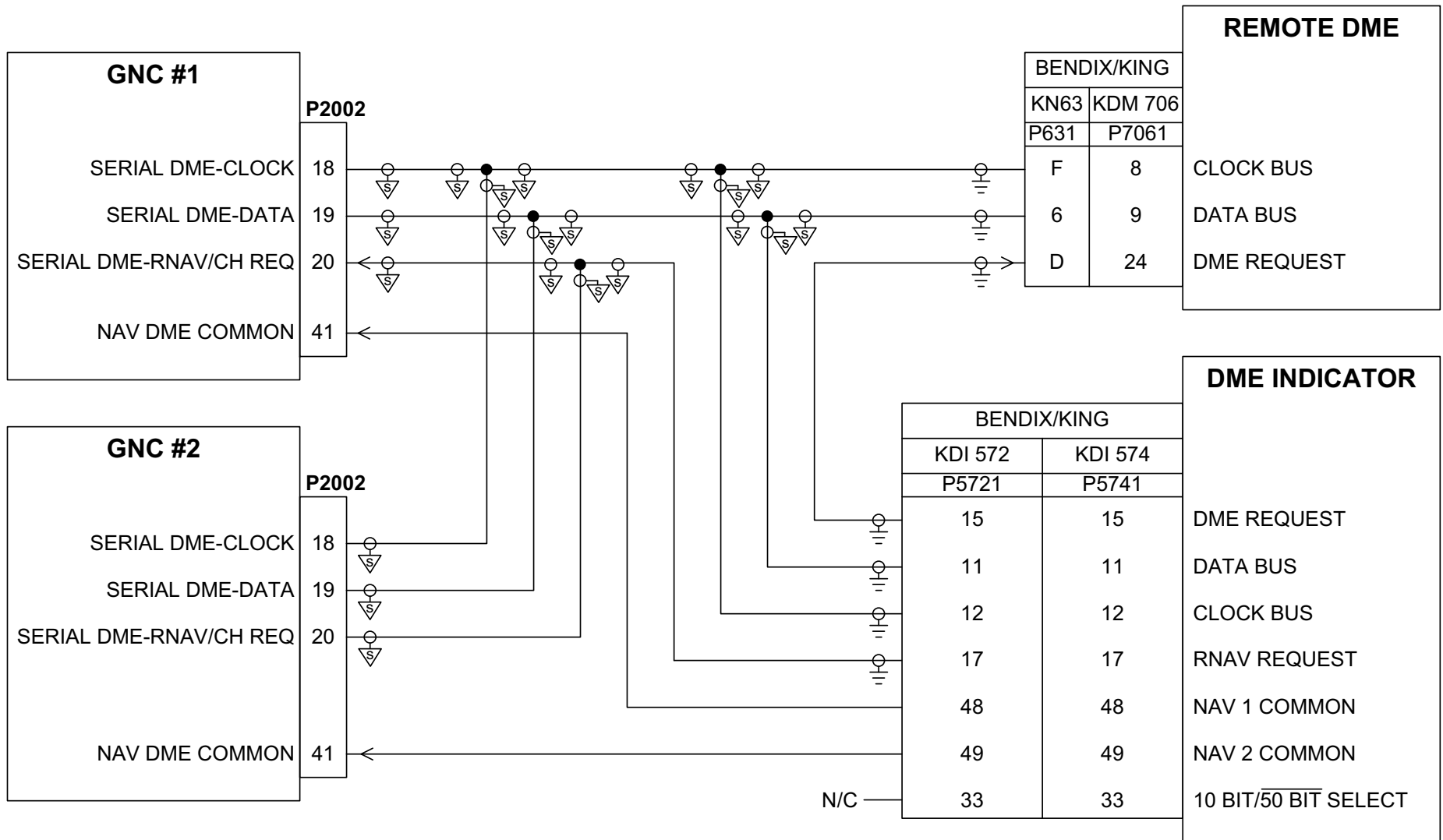




Figure D-10 GNC - King Serial DME - Remote Mount Interconnect  
Sheet 1 of 2

**NOTES**

- 1 ALL WIRES 24 AWG OR LARGER UNLESS OTHERWISE SPECIFIED.
- 2 GROUND DESIGNATIONS:  SHIELD BLOCK GROUND  AIRFRAME GROUND
- 3 AT GNC, CONNECT SHIELD GROUNDS TO THE CONNECTOR BACKSHELL -- THE SHIELD TERMINATION LEADS SHOULD BE LESS THAN 3.0".
- 4 REFER TO MANUFACTURER'S DOCUMENTATION FOR COMPLETE PINOUT AND INTERCONNECT INFORMATION. PINOUTS OF OTHER UNITS SHOWN FOR REFERENCE ONLY.
- 5 THE GNC MAY BE CONFIGURED AT INSTALLATION TO OUTPUT KING SERIAL DME TUNING DATA UNDER THE DME CHANNEL MODE. SEE SECTION 6.4.2.4 FOR CONFIGURATION SETTINGS.
- 6 FOR SINGLE GNC INSTALLATIONS, WIRE AS SHOWN FOR GNC #1.

**Figure D-10 GNC - King Serial DME - Remote Mount Interconnect**  
**Sheet 2 of 2**

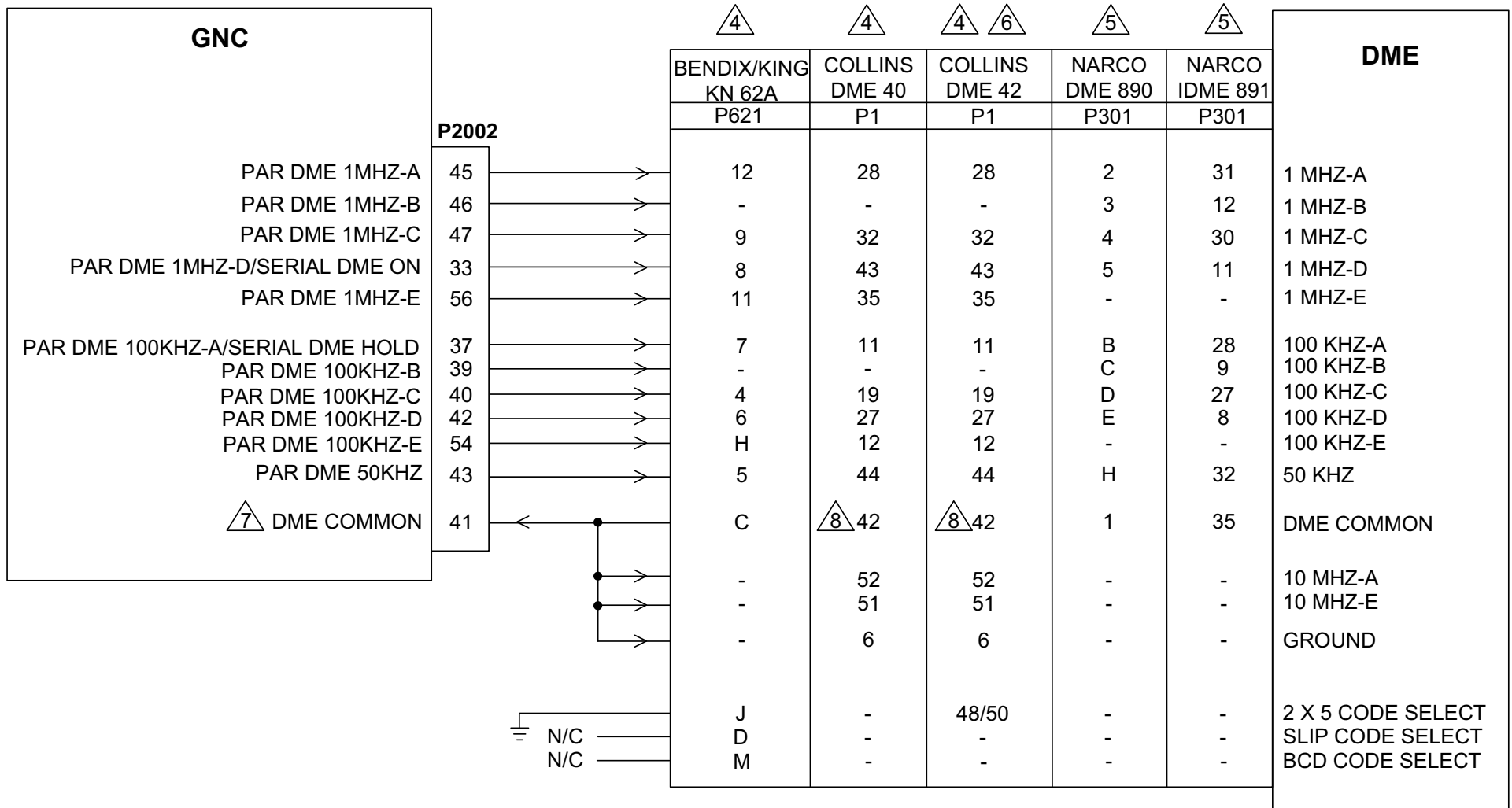






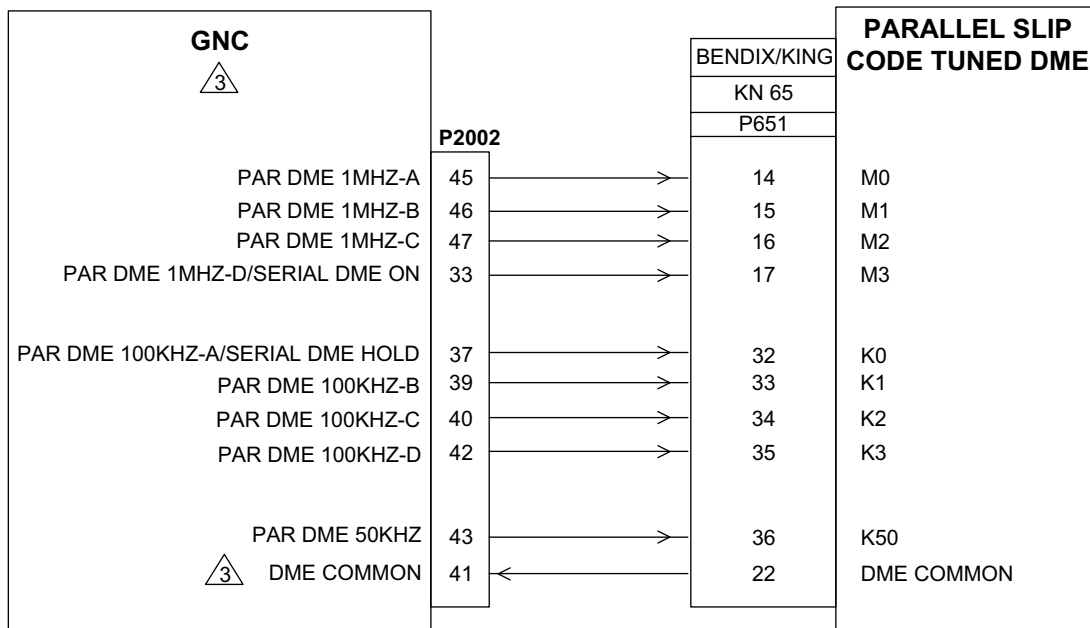


Figure D-11 GNC - Parallel 2 of 5 DME Tuning Interconnect  
Sheet 1 of 2

## NOTES

- 1 ALL WIRES 24 AWG OR LARGER UNLESS OTHERWISE SPECIFIED.
- 2 GROUND DESIGNATION:  AIRFRAME GROUND
- 3 REFER TO MANUFACTURER'S DOCUMENTATION FOR COMPLETE PINOUT AND INTERCONNECT INFORMATION. PINOUTS OF OTHER UNITS SHOWN FOR REFERENCE ONLY. SEE SECTION 6.4.2.4 FOR GNC CONFIGURATION SETTINGS.
-  THE GNC SHOULD BE CONFIGURED FOR PARALLEL 2X5 DME CHANNELING MODE FOR PROPER OPERATION WITH THIS MODEL OF DME TRANSCEIVER.
-  THE GNC SHOULD BE CONFIGURED FOR NARCO 890/891 DME CHANNELING MODE FOR PROPER OPERATION WITH THIS MODEL OF DME TRANSCEIVER.
-  DME 42 SHOULD BE STRAPPED FOR 2X5 TUNING. REFER TO COLLINS DME 42 INSTALLATION MANUAL FOR STRAPPING INFORMATION.
-  FOR DUAL GNC INTERFACES TO THE DME, IT MAY BE NECESSARY TO INSTALL A TOGGLE SWITCH FOR THE "DME COMMON" INPUT. INSTALL SWITCH AS SHOWN FOR KING SERIAL PANEL DME INTERCONNECT.
-  P1-42 ON THE DME AND P3-46 ON THE COLLINS HSI PROCESSOR UNIT HPU-75 NEED TO BE DISCONNECTED FROM GROUND IN ORDER TO ENTER DME HOLD MODE, IF DESIRED.

**Figure D-11 GNC - Parallel 2 of 5 DME Tuning Interconnect  
Sheet 2 of 2**



**NOTES**

- 1 ALL WIRES 24 AWG OR LARGER UNLESS OTHERWISE SPECIFIED.
- 2 REFER TO MANUFACTURER'S DOCUMENTATION FOR COMPLETE PINOUT AND INTERCONNECT INFORMATION. PINOUTS OF OTHER UNITS SHOWN FOR REFERENCE ONLY.
- 3 THE GNC SHOULD BE CONFIGURED TO OUTPUT SLIP CODE DME TUNING DATA FOR PROPER OPERATION IN THIS CONFIGURATION. SEE SECTION 6 FOR CONFIGURATION SETTINGS.
- 4 FOR DUAL GNC INTERFACES TO THE DME, IT MAY BE NECESSARY TO INSTALL A TOGGLE SWITCH FOR THE "DME COMMON" INPUT. INSTALL SWITCH AS SHOWN FOR KING SERIAL PANEL DME INTERCONNECT.

**Figure D-12 GNC - Parallel Slip Code DME Tuning Interconnect**

### KING SERIAL DME (PANEL-MOUNTED DME)

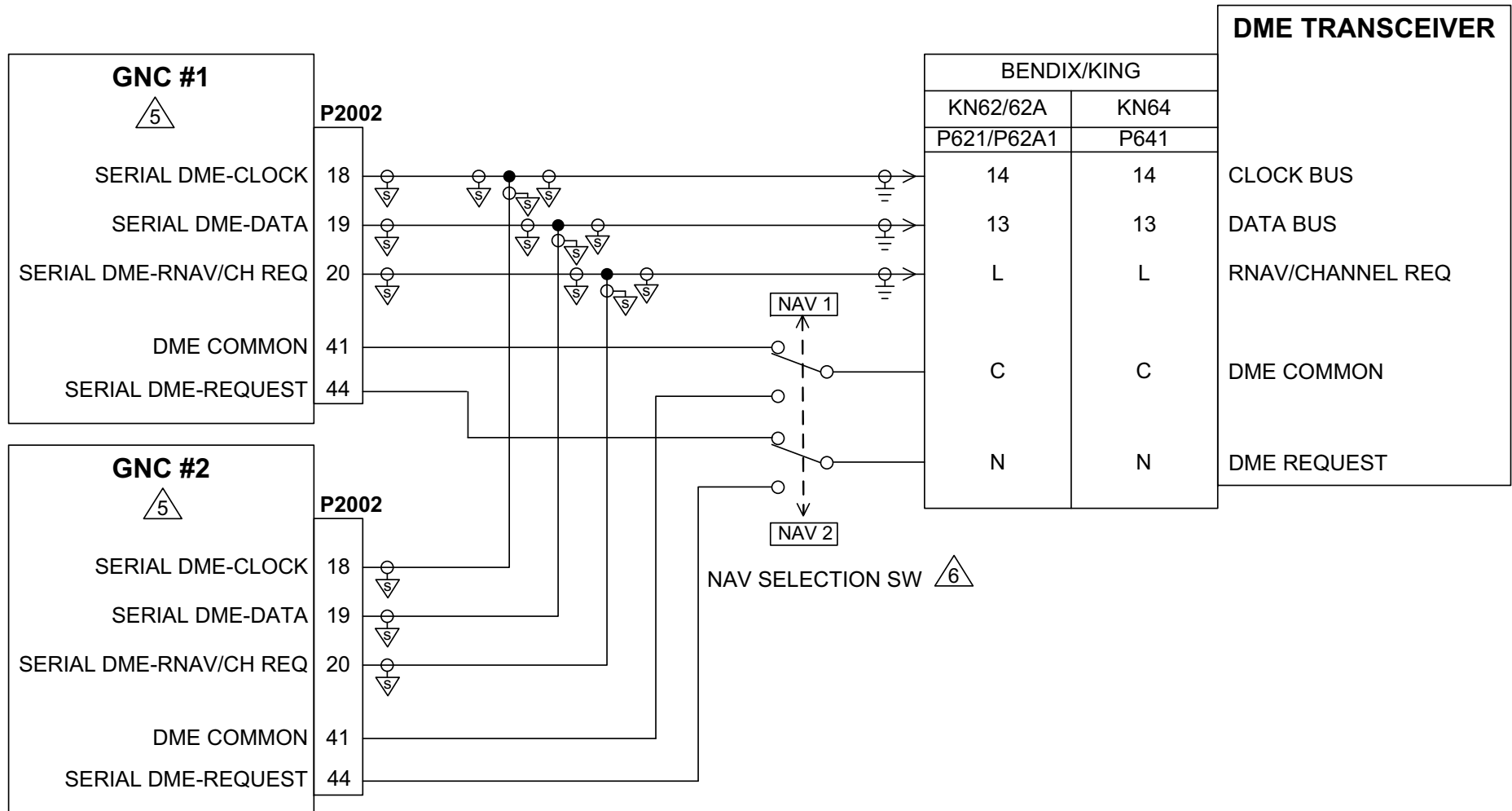


Figure D-13 GNC - King Serial DME - Panel Mount Interconnect  
Sheet 1 of 2

## NOTES

1 ALL WIRES 24 AWG OR LARGER UNLESS OTHERWISE SPECIFIED.

2 GROUND DESIGNATIONS:  SHIELD BLOCK GROUND  AIRFRAME GROUND

3 AT GNC, CONNECT SHIELD GROUNDS TO THE CONNECTOR BACKSHELL -- THE SHIELD TERMINATION LEADS SHOULD BE LESS THAN 3.0". CONNECT OTHER END OF THE SHIELD PER THE REMOTE EQUIPMENT INSTALLATION REQUIREMENTS. IF NO SHIELD TERMINATION REQUIREMENT EXISTS FOR THE REMOTE EQUIPMENT, TERMINATE SHIELDS AS SHORT AS POSSIBLE, NOT TO EXCEED 3.0".

4 REFER TO MANUFACTURER'S DOCUMENTATION FOR COMPLETE PINOUT AND INTERCONNECT INFORMATION. PINOUTS OF OTHER UNITS SHOWN FOR REFERENCE ONLY.

 5

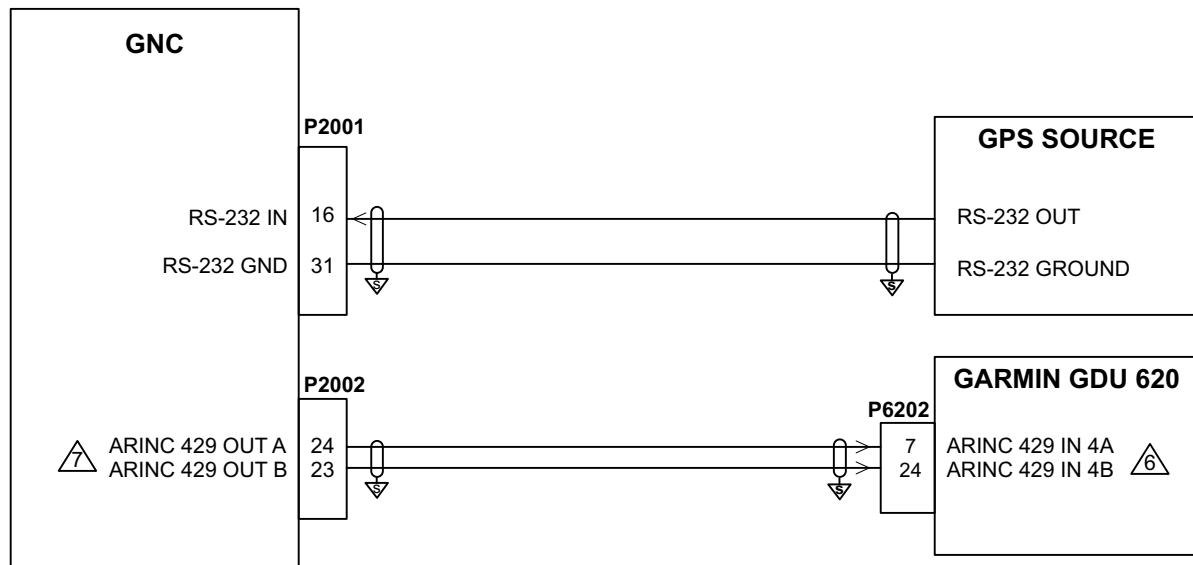
THE GNC MAY BE CONFIGURED AT INSTALLATION TO OUTPUT KING SERIAL DME TUNING DATA UNDER THE DME CHANNEL MODE. SEE SECTION 6.4.2.4 FOR CONFIGURATION SETTINGS.

 6




THE NAV SELECTION SWITCH IS ONLY REQUIRED IF TWO GNCS ARE INSTALLED. FOR SINGLE GNC INSTALLATIONS, WIRE AS SHOWN FOR GNC #1. USE A DOUBLE POLE, DOUBLE THROW, ON-NONE-ON SWITCH. AN ACCEPTABLE SWITCH IS CARLINGSWITCH P/N 316-B-63. LABEL AS SHOWN.

**Figure D-13 GNC - King Serial DME - Panel Mount Interconnect  
Sheet 2 of 2**

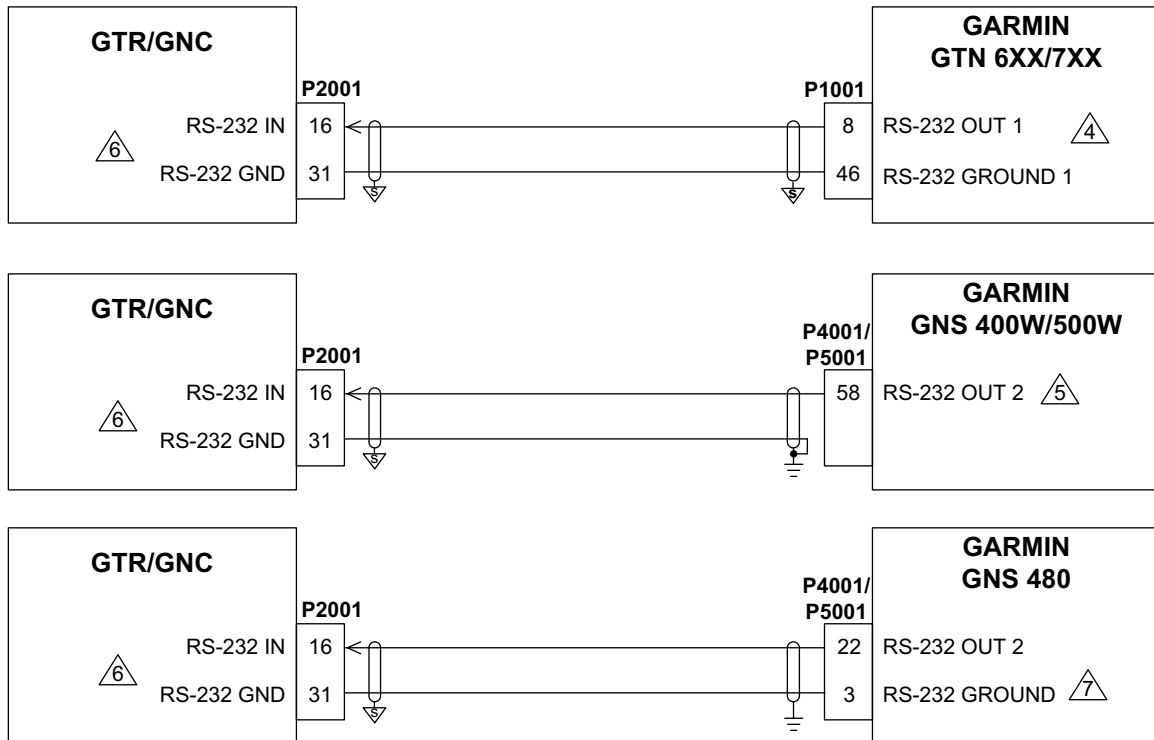










**NOTES**

- 1 ALL WIRES 24 AWG OR LARGER UNLESS OTHERWISE SPECIFIED.
- 2 GROUND DESIGNATION:  SHIELD BLOCK GROUND
- 3 AT GNC, CONNECT SHIELD GROUNDS TO THE CONNECTOR BACKSHELL – THE SHIELD TERMINATION LEADS SHOULD BE LESS THAN 3.0". CONNECT OTHER END OF THE SHIELD PER THE REMOTE EQUIPMENT INSTALLATION REQUIREMENTS.
- 4 REFER TO GDU 620 INSTALLATION MANUAL FOR COMPLETE PINOUT AND INTERCONNECT INFORMATION.
- 5 SELECTED COURSE INPUT TO THE GNC IS NOT PROVIDED BY THE GDU 620 IN THIS CONFIGURATION. CONFIGURE THE GNC CDI INDICATOR TYPE TO "NONE." THE GNC WILL SEND NAVIGATION DATA TO THE GDU 620 OVER ARINC 429, WHICH ALLOWS THE GNC RS-232 INPUT TO BE USED FOR A GPS SOURCE. SEE FIGURE D-15 FOR GPS SOURCE INTERCONNECT DETAILS.
-  REFER TO GDU 620 INSTALLATION MANUAL, FOR NAV INPUT OPTIONS AND CONFIGURATION. CONFIGURE THE GDU 620 TO USE AN ARINC 429 NAV RADIO, SUCH AS GNS 430W. ANY AVAILABLE ARINC 429 PORTS MAY BE USED ON THE GDU 620.
-  CONFIGURE ARINC 429 TX TO LO SPEED AND SDI TO VOR/ILS 1 OR VOR/ILS 2 (TO MATCH NAV 1 OR NAV 2 INPUT ON GDU 620).

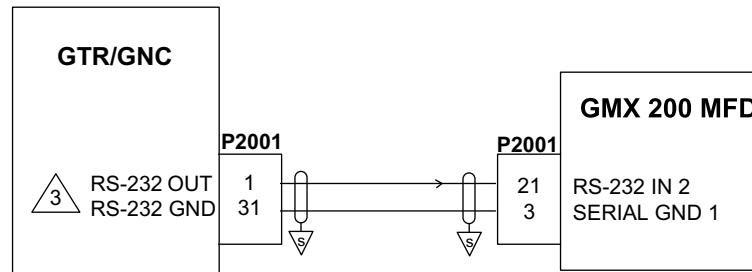
**Figure D-14 GNC - GDU 620 Interconnect**



**NOTES**


- 1 ALL WIRES 24 AWG OR LARGER UNLESS OTHERWISE SPECIFIED.
- 2 GROUND DESIGNATIONS:  SHIELD BLOCK GROUND  AIRFRAME GROUND
- 3 AT GTR/GNC, CONNECT SHIELD GROUNDS TO THE CONNECTOR BACKSHELL – THE SHIELD TERMINATION LEADS SHOULD BE LESS THAN 3.0". CONNECT OTHER END OF THE SHIELD PER THE REMOTE EQUIPMENT INSTALLATION REQUIREMENTS.
-  4 CONFIGURE RS-232 OUTPUT TO "AVIATION FORMAT 1" FORMAT. ANY AVAILABLE RS-232 OUTPUT PORT MAY BE USED.
-  5 CONFIGURE RS-232 OUTPUT TO "AVIATION" FORMAT. ANY AVAILABLE RS-232 OUTPUT PORT MAY BE USED.
-  6 CONFIGURE GTR/GNC SERIAL PORT FOR "AVN IN/MAPCOM."
-  7 CONFIGURE RS-232 OUTPUT TO "MAPCOM" FORMAT. RS-232 OUTPUT PORT 1 OR PORT 5 MAY BE USED.


**Figure D-15 GTR/GNC - GTN 6XX/7XX, GNS 400W/500W, and GNS 480 Interconnect**



**NOTES**

1 ALL WIRES 24 AWG OR LARGER UNLESS OTHERWISE SPECIFIED.

2 GROUND DESIGNATION:  SHIELD BLOCK GROUND

 AT GNC, CONNECT SHIELD GROUNDS TO THE CONNECTOR BACKSHELL – THE SHIELD TERMINATION LEADS SHOULD BE LESS THAN 3.0". CONNECT OTHER END OF THE SHIELD PER THE REMOTE EQUIPMENT INSTALLATION REQUIREMENTS.

4 CONFIGURE GNC SERIAL PORT FOR "AVN IN/MAPCOM."

**Figure D-16 GTR/GNC - GMX 200 Interconnect**

**GARMIN**  **®**